

STAGE 1 @ STA. 267+59 LOOKING NORTH  
NO SCALE

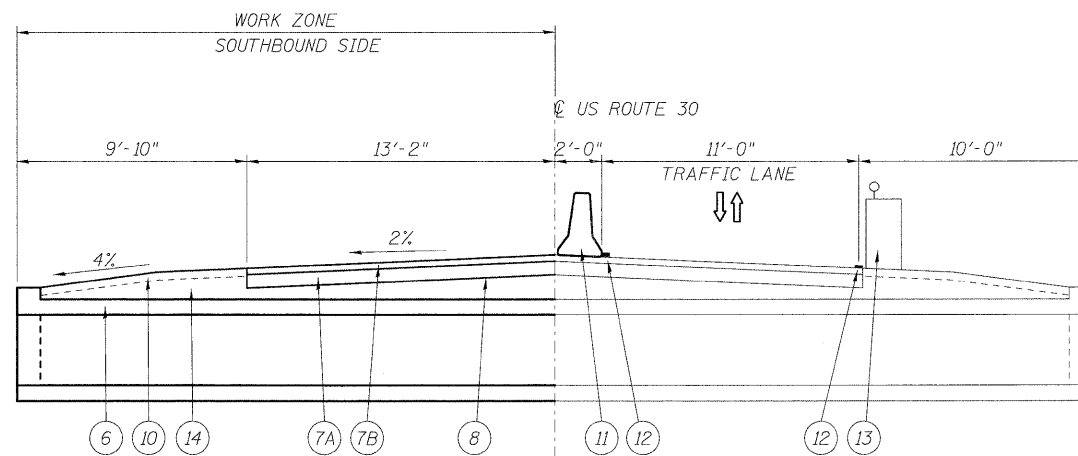

STAGE 2 @ STA. 267+59 LOOKING NORTH  
NO SCALE

**LEGEND**

- ① PAVEMENT REMOVAL
- ② EARTH EXCAVATION
- ③ REMOVAL OF EXISTING STRUCTURES
- ④ STRUCTURE EXCAVATION
- ⑤ REMOVAL AND DISPOSAL OF UNSUITABLE MATERIAL
- ⑥ PRECAST CONCRETE BOX CULVERT 7'x3'
- ⑦A HMA BINDER COURSE IL-19mm, N70, 8½" (IN 3 LIFTS)
- ⑦B HMA SURFACE COURSE MIX D, N70, 1½"
- ⑧ BITUMINOUS MATERIALS (PRIME COAT)
- ⑨ COARSE AGGREGATE BACKFILL (SPECIAL)
- ⑩ COMPOST FURNISH AND PLACE 4"
- ⑪ TEMPORARY CONCRETE BARRIER
- ⑫ PAVEMENT MARKING TAPE, TYPE III, 4" WHITE
- ⑬ DRUM WITH STEADY BURNING LIGHT
- ⑭ CA 7

**NOTE:**

HMA BINDER AND SURFACE COURSE TO BE PAID FOR AS CLASS D PATCHES, TYPE IV, 10" IN SQ.YD.