

EXISTING TYPICAL SECTION
ILLINOIS ROUTE 68
OVER SPRING CREEK
STA 49+90 TO STA 50+10

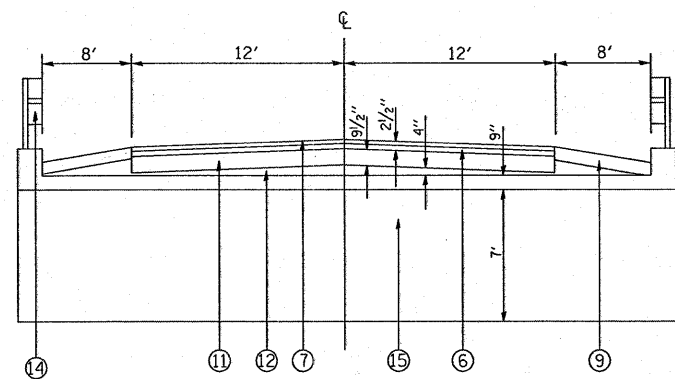

EXISTING TYPICAL SECTION
ILLINOIS ROUTE 68
OVER SPRING CREEK
STA 49+82 TO STA 50+18

LEGEND

- ① EXISTING BOX CULVERT
- ② EXISTING HOT-MIX ASPHALT SURFACE COURSE, 3"
- ③ EXISTING HOT-MIX ASPHALT SHOULDER
- ④ EXISTING AGGREGATE SHOULDER
- ⑤ EXISTING GUARDRAIL (TO BE REMOVED)
- ⑥ PROPOSED LEVELING BINDER (MACHINE METHOD), N50, 1"
- ⑦ PROPOSED HOT-MIX ASPHALT SURFACE COURSE, MIX "D", N50, 1 1/2"
- ⑧ PROPOSED TEMPORARY PAVEMENT (TO REMAIN), 10"
- ⑨ PROPOSED HOT-MIX ASPHALT SHOULDER, 8"
- ⑩ PROPOSED AGGREGATE SHOULDER
- ⑪ PROPOSED PORTLAND CEMENT CONCRETE BASE COURSE, 9 1/2"
- ⑫ PROPOSED SUB-BASE GRANULAR MATERIAL, TYPE B, 4"
- ⑬ PROPOSED HMA STABILIZATION FOR GUARDRAIL, 2.5' WIDE
- ⑭ PROPOSED STEEL RAILING (SEE CULVERT PLANS FOR DETAILS)
- ⑮ PROPOSED BOX CULVERT

NOTES

SEE BRIDGE PLANS FOR STRUCTURE EXCAVATION DETAILS FROM STA. 49+82 TO STA. 49+90 AND STA. 50+10 TO STA. 50+18

FILE NAME =	USER NAME = sm:thkl	DESIGNED -	REVISED -	STATE OF ILLINOIS DEPARTMENT OF TRANSPORTATION	EXISTING AND PROPOSED TYPICAL SECTIONS IL 68 OVER SPRING CREEK - S.N. 016-2811	F.A.P. RTE.	SECTION	COUNTY	TOTAL SHEETS	SHEET NO.	
ca:\pw_work\VPWIDOT\SMITHKL\dms92925\design_00.dgn		DRAWN -	REVISED -			343	631T	COOK	33	6	
PLOT SCALE = 50.0000' / IN.		CHECKED -	REVISED -			CONTRACT NO. 62710					
PLOT DATE = 12/23/2008		DATE -	REVISED -			SCALE:	SHEET NO. OF SHEETS	STA. TO STA.	FED. ROAD DIST. NO.	ILLINOIS FED. AID PROJECT	