

DATE	
BY	
REVISIONS	
PLANNED	
GRADES CHECKED	
ALIGNMENT CHECKED	
NOTE BOOK	
NO.	
ADD FILE NAME	

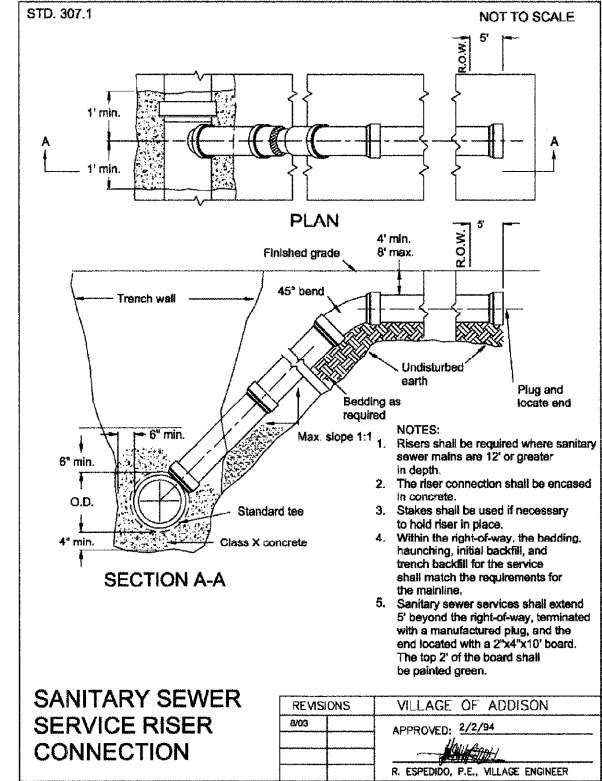

DATE	
BY	
REVISIONS	
PLANNED	
GRADES CHECKED	
ALIGNMENT CHECKED	
NOTE BOOK	
NO.	
ADD FILE NAME	

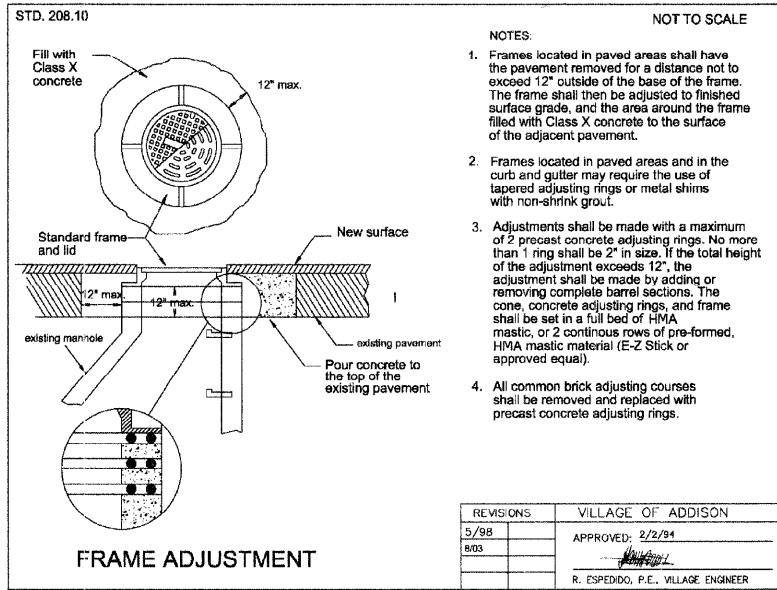
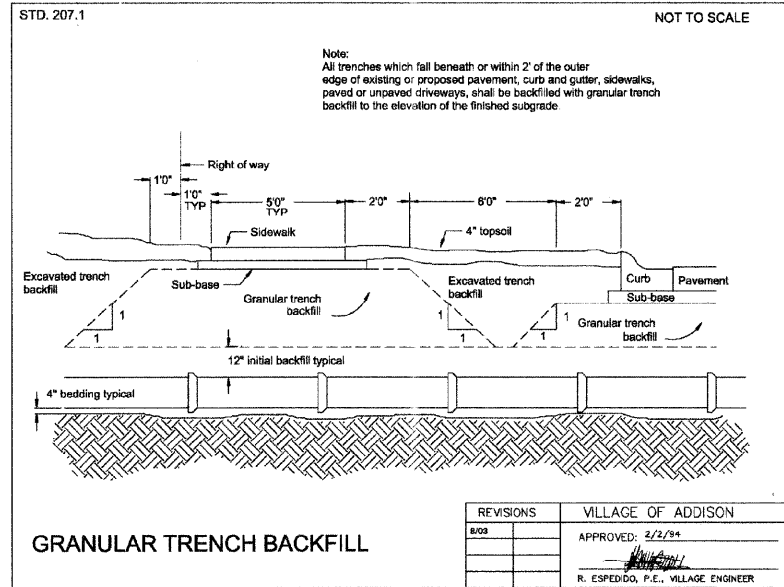
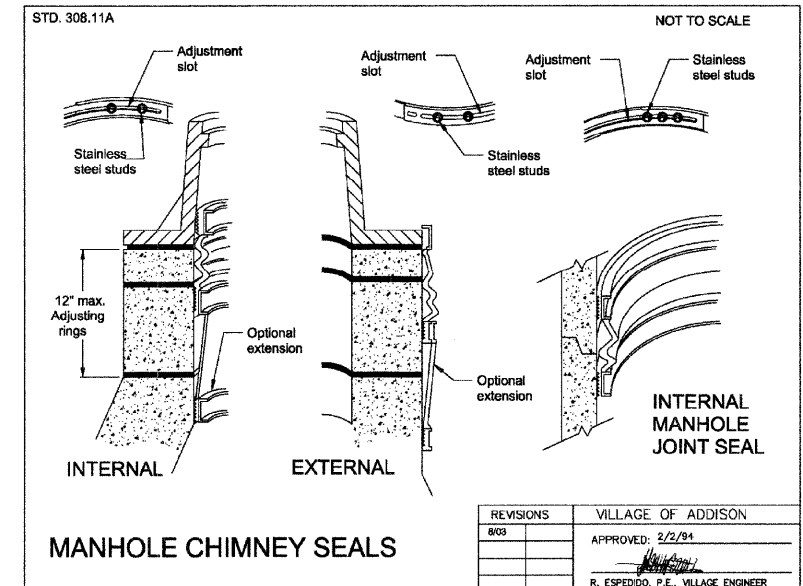
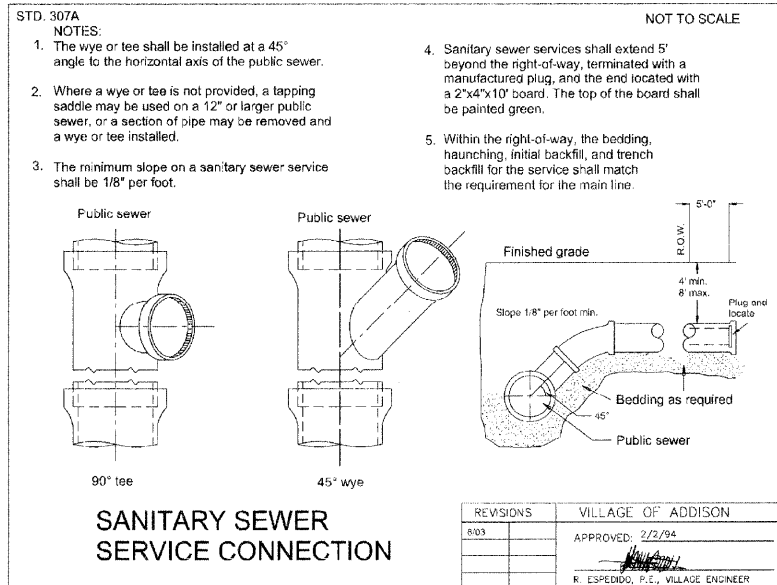
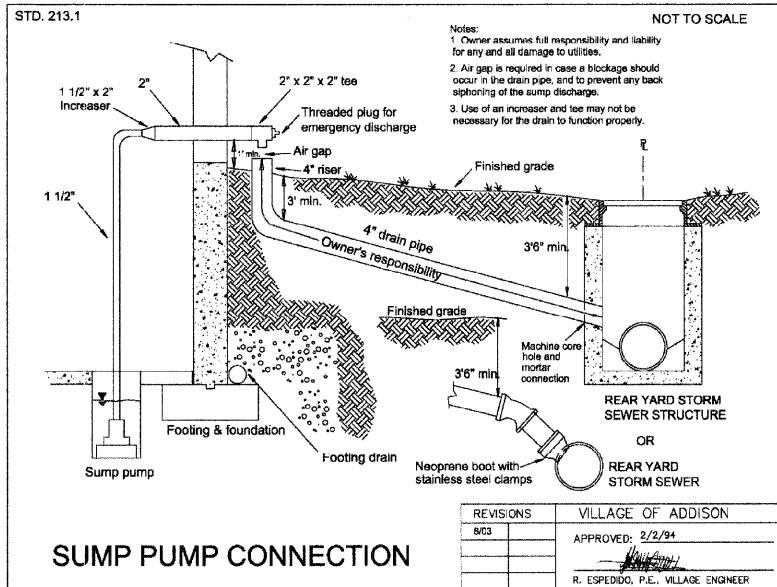
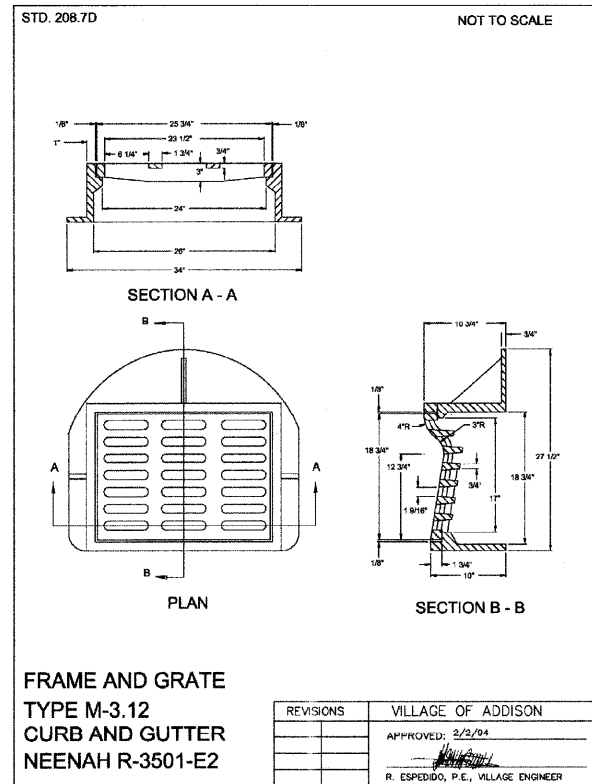

FILE NAME = J:\2192\oad\sheet\06_DET\2192_DET.dgn

USER NAME = jrr
PLOT SCALE = 1.0000" / 1"
PLOT DATE = 11/18/2008

DESIGNED - PEAB
DRAWN - JRRR
CHECKED - RFTM
DATE - 11/21/2008

REVISED -
REVISED -
REVISED -
REVISED -



450 E. Devon Ave., Suite 300 - Itasca, Illinois 60143
Tel: 630.773.3900 • Fax: 630.773.3975
www.civiltechinc.com

CONSTRUCTION DETAILS - ADDISON ROAD

SHEET NO. 30 OF 46 SHEETS

FA RTE	SECTION	COUNTY	TOTAL SHEETS	SHEET NO.
2642	06-00095-00-RS	DUPAGE	46	30
CONTRACT NO. 63100				
FED ROAD DIST NO. ILLINOIS FED AID PROJECT				