

ELEVATION

GENERAL NOTES:

- ① Contraction Joints shall be sawed as indicated hereon. Where abutting sections are placed as separate pours, a butt joint may be used. Longitudinal reinforcement shall be extended in the abutting section a minimum of 1'-6" (spanning the butt joint).
- ② For barrier doweled to PC paved shoulders, match pavement joints. For barrier on HMA, use 20 feet.
- ③ 1 inch diameter deformed bars or sufficient length to ensure 6 inch minimum embedment in rail and supporting surface. Bars shall be either installed in supporting surface when placed or installed in drilled holes using polymer grout or hydraulic cement grout. Dower location may be adjusted 6 inches to avoid bridge approach reinforcement.
- ④ Use minimum cover of 2 inches for rebars.
- ⑤ All exposed corners are to be filleted with a $\frac{3}{4}$ " dressed and beveled strip.
- ⑥ Barrier markers to be spaced at 250 feet increments in areas with continuous lighting, 100 feet increments in areas with non-continuous lighting.
- ⑦ Barrier reinforcement shall be anchored to prevent movement. Each section shall be secured at the front, back, and at 3'-6" minimum intervals. Method of anchorage shall be approved by the Engineer.
- ⑧ This work shall be paid for at the contract unit price per foot as Concrete Barrier Wall (Special).

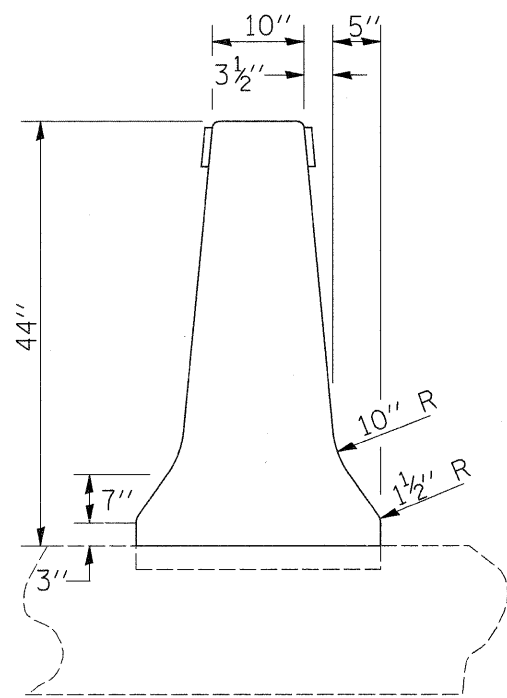

DETAILS OF F-SHAPE BARRIER FACE

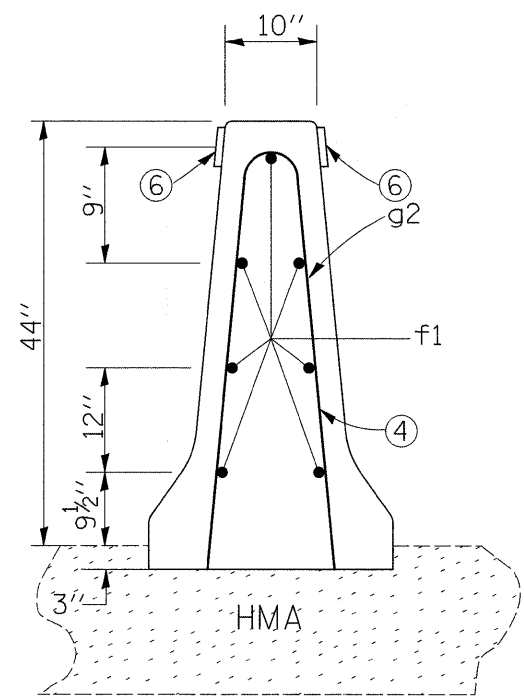

SECTION A-A

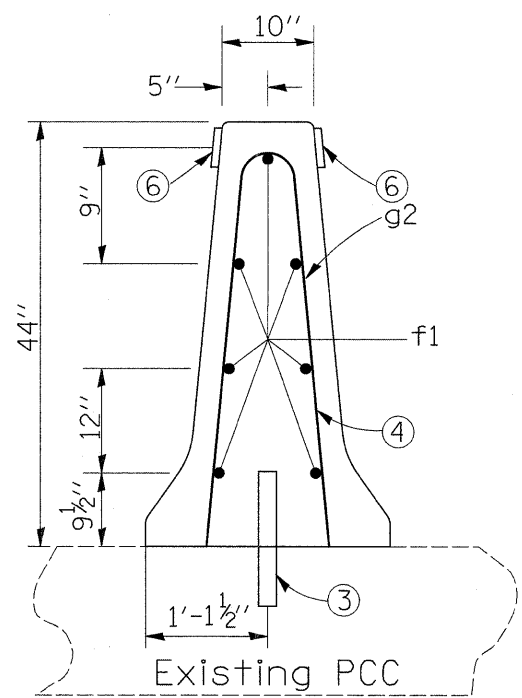

SECTION A-A

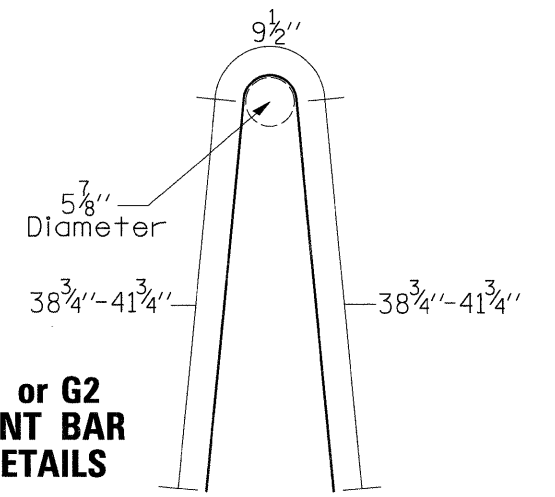
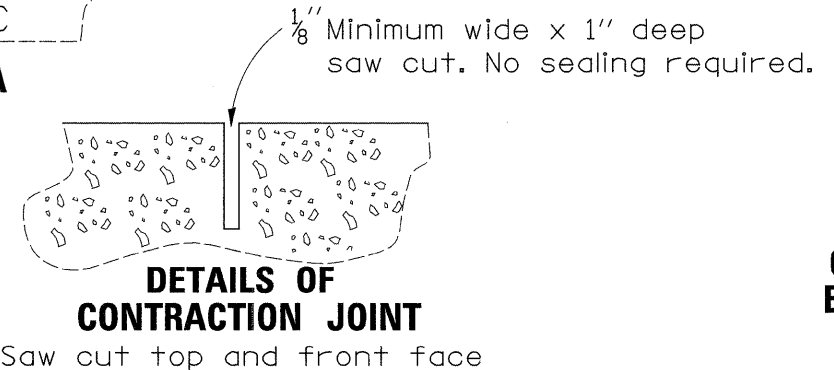

REINFORCING BAR LIST				
Per Section (Approx. 20 feet)				
Mark	Size	Number of Bars	Length	WT. (lbs.)
g1	5	14	7'-3"	107
g2	5	14	7'-9"	113
f1	5	7	19'-6"	141

CONCRETE QUANTITIES
Per Foot
0.15 cy