

LOOP CABLE ROUTING DETAILS

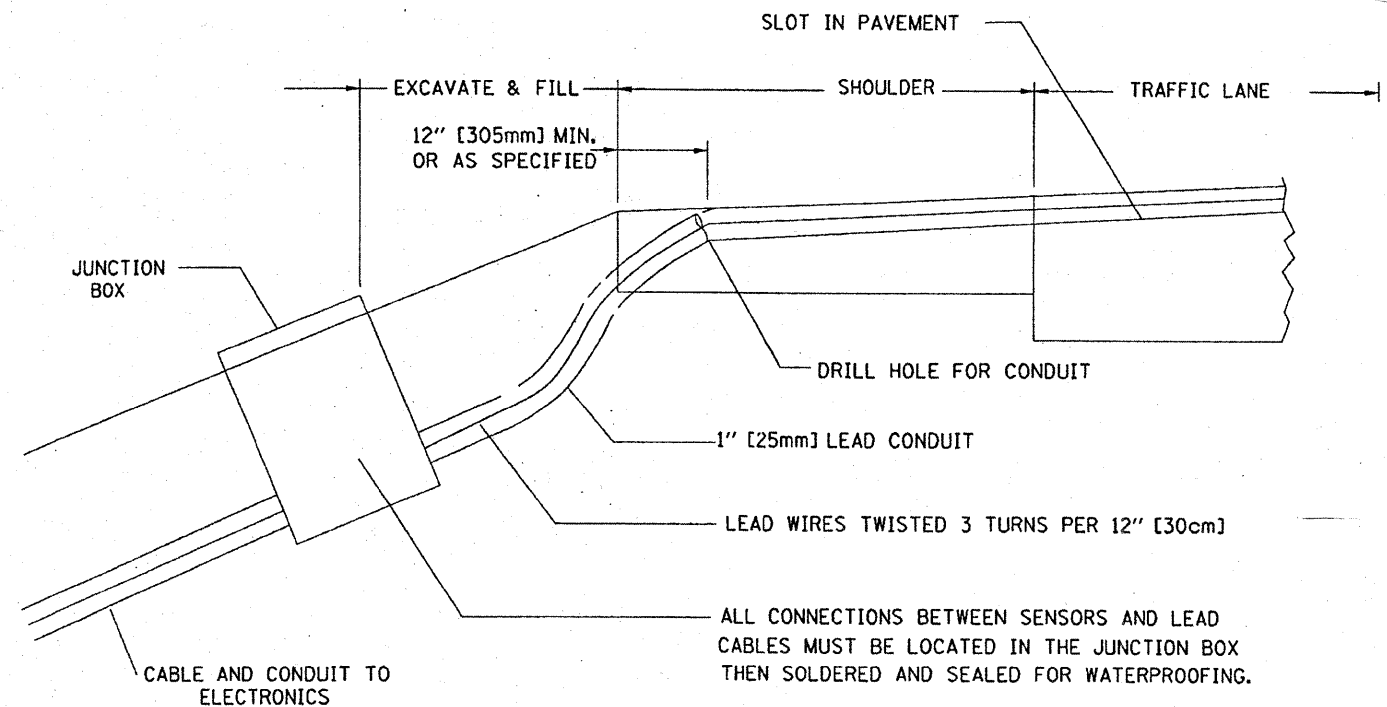

SECTION B-B - PIEZO SENSOR DETAIL

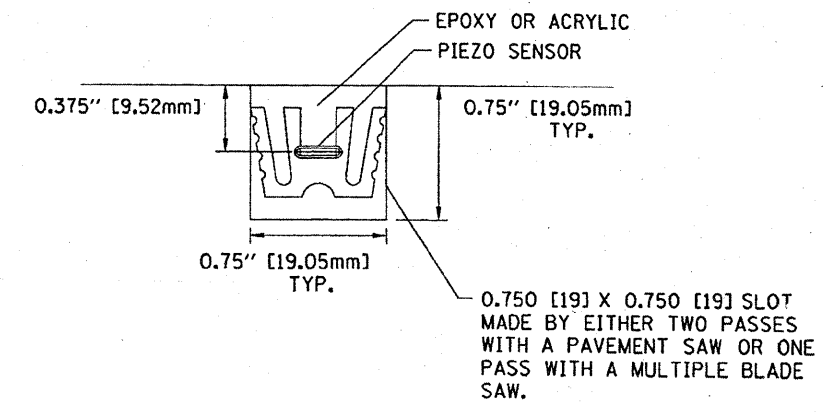

LOOP DIMENSION DETAIL

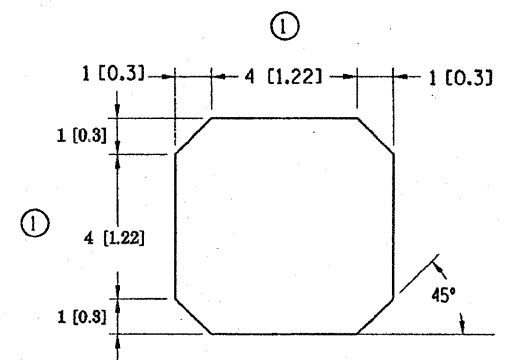

SECTION A-A - LOOP DETAIL

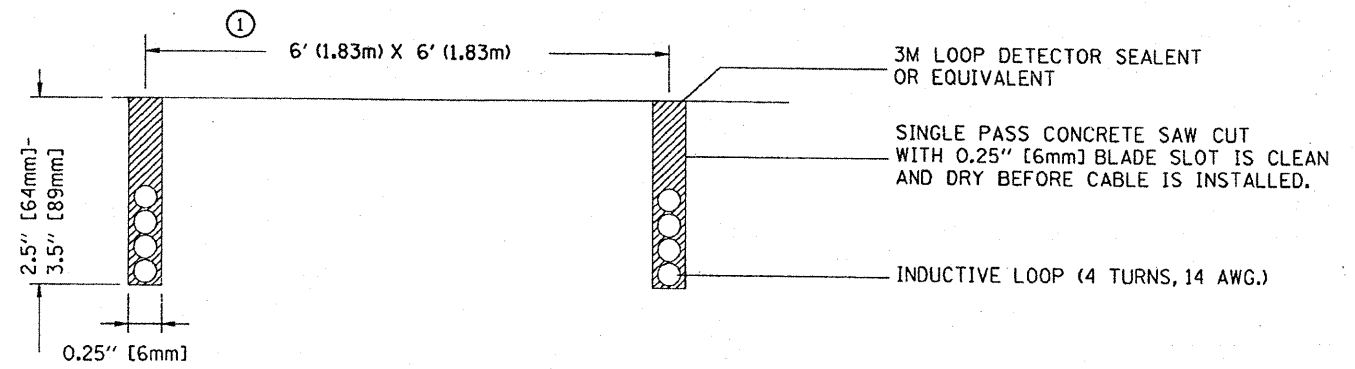

NOTES:

- ① 6' x 6' LOOP SHOWN. FOR SIZE, REFER TO LOOP DETAILS ON SITE LAYOUT DRAWING.
- ② 4 TURN LOOP SHOWN. FOR NUMBER OF TURNS, REFER TO LOOP DETAILS ON SITE LAYOUT DRAWING.

FILE NAME =	USER NAME = grantpm	DESIGNED -	REVISED -	STATE OF ILLINOIS DEPARTMENT OF TRANSPORTATION	WEIGH-IN-MOTION SCALE DETAILS			F.A.I. RTE.	SECTION	COUNTY	TOTAL SHEETS	SHEET NO.
ct:\pw\work\pwidot\grantpm\dms34287\d08403sp1.dgn	PLOT SCALE = 50.0000' / IN.	DRAWN -	REVISED -					80	(81-1) R-1	ROCK ISLAND	292	207
PLOT DATE = Wed Oct 08 08:34:43 2008	DATE -	CHECKED -	REVISED -					CONTRACT NO. 64933				
		DATE -	REVISED -					SCALE:	SHEET NO.	OF SHEETS	STA.	TO STA.
								FE ⁰⁰ , ROAD DIST. NO. ILLINOIS FED. AID PROJECT				