

HOT-MIX ASPHALT SHOULDER CURB

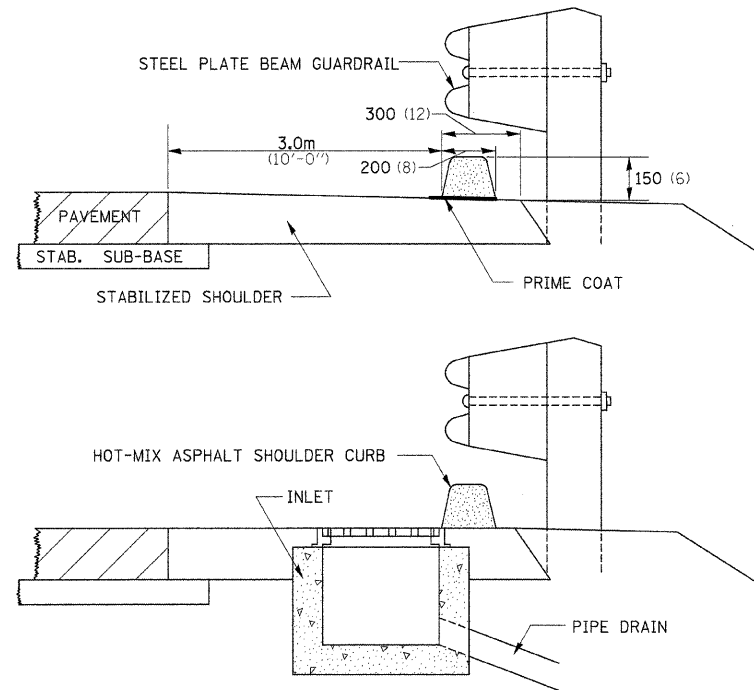

CURB DETAIL

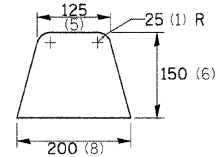

GENERAL NOTES

THIS WORK SHALL BE DONE AS SPECIFIED UNDER SECTION 661 OF THE STANDARD SPECIFICATIONS FOR HOT-MIX ASPHALT CURB.

THE METAL PIPES AND INLETS SHALL BE INSTALLED AS DIRECTED BY THE ENGINEER.

THE BITUMINOUS MATERIALS PRIME COAT SHALL BE CONSIDERED INCLUDED TO THE HOT-MIX ASPHALT SHOULDER CURBS.

ALL DIMENSIONS ARE IN MILLIMETERS (INCHES) UNLESS OTHERWISE NOTED.

REVISED - 11-01-07

HOT-MIX ASPHALT SHOULDER CURB 10.4

DETAIL OF HOT-MIX ASPHALT SHOULDER AT GUARD RAIL

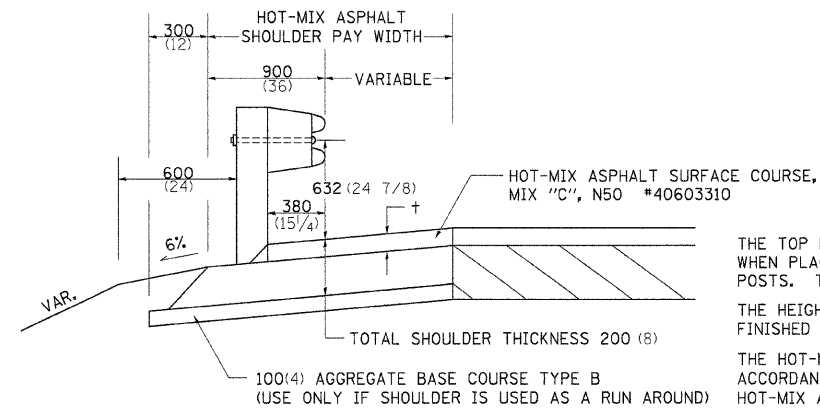

† = SEE TYPICAL SECTIONS FOR THICKNESS

GENERAL NOTES

THE TOP LIFT SHALL NOT BE PLACED BEHIND THE GUARDRAIL POSTS. WHEN PLACING THE TOP LIFT THE RAIL MUST BE REMOVED FROM THE POSTS. THE POST SHALL NOT BE REMOVED.

THE HEIGHT OF THE GUARD RAIL SHALL BE SET 632 (24 7/8) FROM THE FINISHED SURFACE.

THE HOT-MIX ASPHALT SHOULDER SHALL BE CONSTRUCTED IN ACCORDANCE WITH SECTION 482 EXCEPT THE TOP LIFT SHALL BE HOT-MIX ASPHALT SURFACE COURSE, MIXTURE C, N50. THE WORK WILL BE PAID FOR AT THE CONTRACT UNIT PRICE PER TON FOR HOT-MIX ASPHALT SURFACE COURSE, MIXTURE "C", N50 AND SQUARE METER (SQUARE YARD) FOR HOT-MIX ASPHALT SHOULDERS OF THE THICKNESS SPECIFIED. THE REMOVAL & REINSTALLATION OF THE GUARDRAIL WILL BE INCLUDED IN THE COST OF THE HOT-MIX ASPHALT SURFACE COURSE, MIXTURE C, N50.

ALL DIMENSIONS ARE IN MILLIMETERS (INCHES) UNLESS OTHERWISE NOTED.

REVISED - 11-01-07

DETAIL OF HOT-MIX ASPHALT SHOULDER AT GUARD RAIL 23.4

HOT-MIX ASPHALT SHOULDER

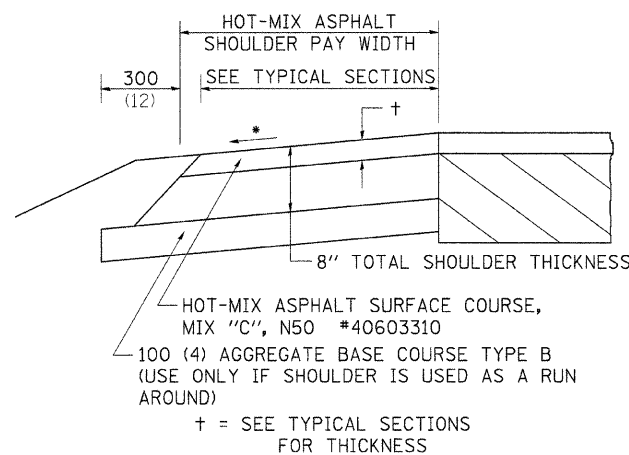

GENERAL NOTES

THE HOT-MIX ASPHALT SHOULDER SHALL BE CONSTRUCTED IN ACCORDANCE WITH SECTION 482 EXCEPT THE TOP LIFT SHALL BE HOT-MIX ASPHALT SURFACE COURSE, MIX "C", N50 #40603310. THE WORK WILL BE PAID FOR AT THE CONTRACT UNIT PRICE PER TON FOR HOT-MIX ASPHALT SURFACE COURSE, MIX "C", N50 #40603310 AND SQUARE YARD FOR HOT-MIX ASPHALT SHOULDERS OF THE THICKNESS SPECIFIED.

USE HOT-MIX ASPHALT SURFACE COURSE, MIX "C", N50 #40603310. WHEN RESURFACING EXISTING HOT-MIX ASPHALT SHOULDERS. THE THICKNESS IS SHOWN ON THE TYPICAL SECTIONS. THIS WORK WILL BE PAID FOR AT THE CONTRACT UNIT PRICE PER TON FOR HOT-MIX ASPHALT SURFACE COURSE, MIX "C", N50 #40603310.

REMOVAL OF MATERIAL FOR PLACEMENT OF THE HOT-MIX ASPHALT SHOULDER TO BE PAID FOR IN UNITS FOR EXCAVATING AND GRADING EXISTING SHOULDERS OR IN CUBIC YARDS FOR EARTH EXCAVATION OR EARTH EXCAVATION WIDENING.

* 4% WHEN MAINLINE IS ON TANGENT. FOR CROSS SLOPE ON SUPERELEVATION SECTION, SEE HIGHWAY STANDARD 482001 OR 482006.

ALL DIMENSIONS ARE IN MILLIMETERS (INCHES) UNLESS OTHERWISE NOTED.

REVISED - 11-01-07

HOT-MIX ASPHALT SHOULDER 23.4a

DELINEATOR AND POST ORIENTATION

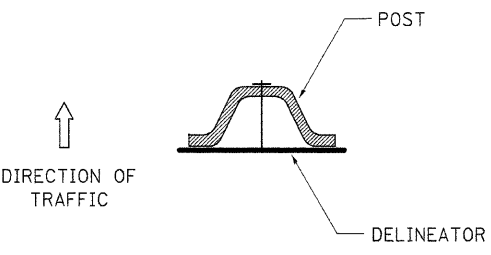
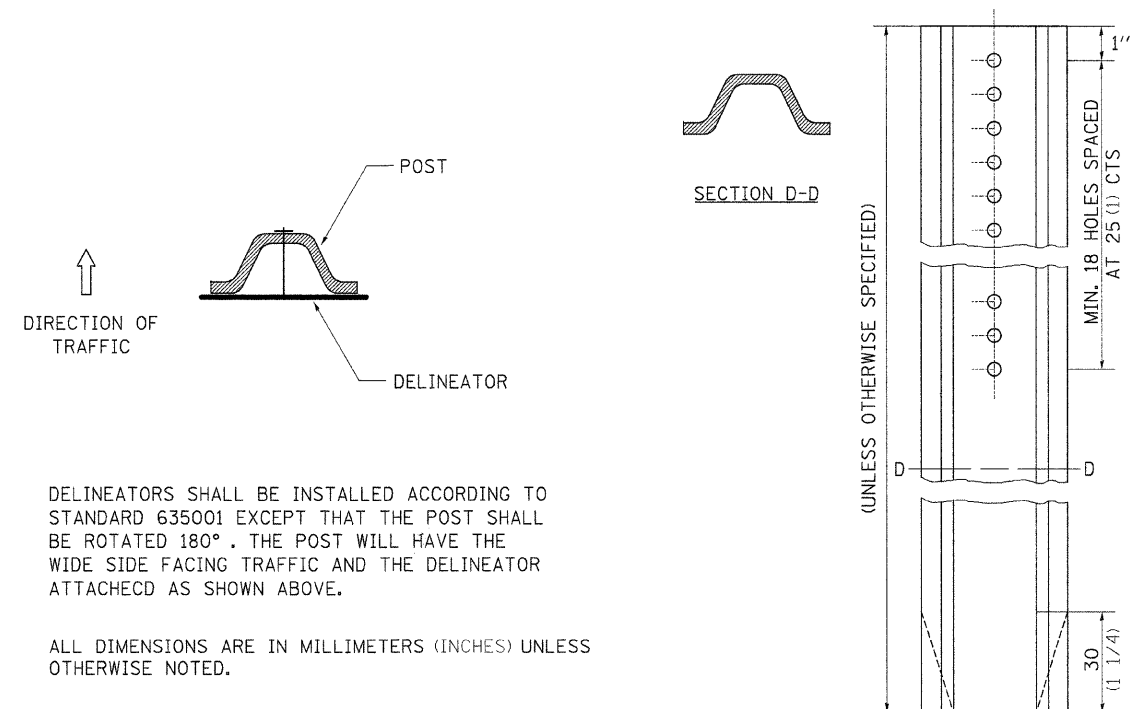

DELINEATORS SHALL BE INSTALLED ACCORDING TO STANDARD 635001 EXCEPT THAT THE POST SHALL BE ROTATED 180°. THE POST WILL HAVE THE WIDE SIDE FACING TRAFFIC AND THE DELINEATOR ATTACHED AS SHOWN ABOVE.

ALL DIMENSIONS ARE IN MILLIMETERS (INCHES) UNLESS OTHERWISE NOTED.

REVISED - 11-01-07

DELINEATOR AND POST ORIENTATION 37.4

REVISED - ---	REGION 2 / DISTRICT 2 STANDARD	F.A. RTE.	SECTION	COUNTY	TOTAL SHEETS	SHEET NO.	
REVISED - ---		308	1103C-1BR1D	JO DAVIESS	62	16	
REVISED - ---		CONTRACT NO. 64C03					
REVISED - ---		FED. ROAD DIST. NO. ILLINOIS FED. AID PROJECT					