

HORIZONTAL & VERTICAL CONTROL SHEETS

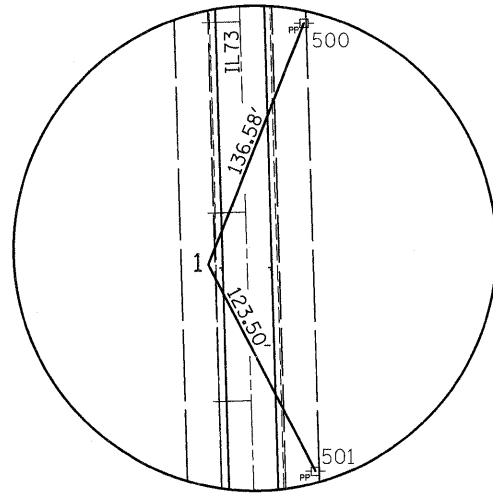

HORIZONTAL CONTROL POINT NO. 1

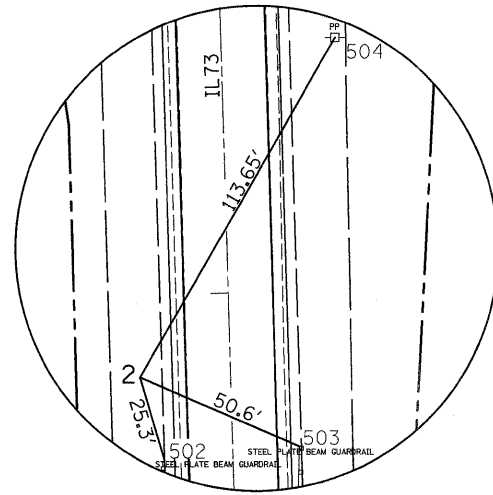

HORIZONTAL CONTROL POINT NO. 2

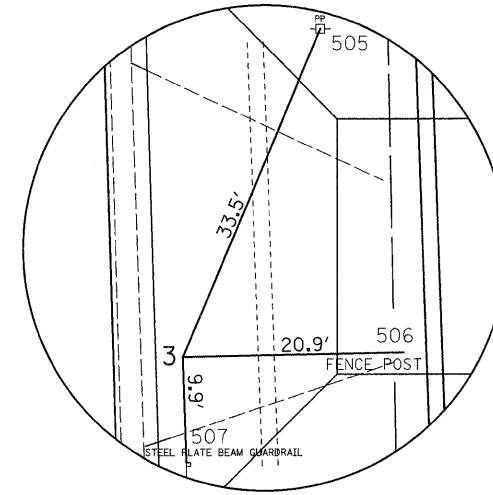

HORIZONTAL CONTROL POINT NO. 3

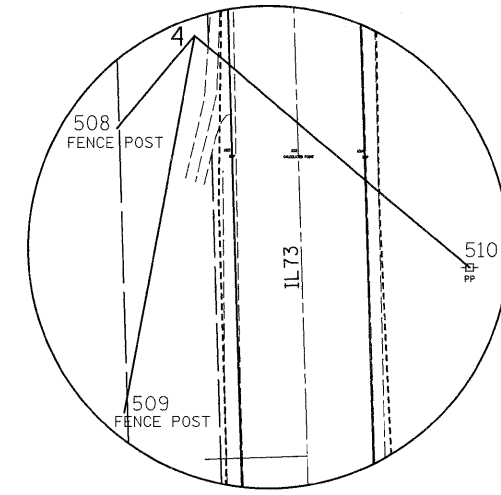

HORIZONTAL CONTROL POINT NO. 4

HORIZONTAL CONTROL POINTS

POINT	NORTH	EAST	ELEVATION	CHAIN	STATION	OFFSET	DESCRIPTION
1	2062479.0260	2388222.0990	891.1240	STE73	476+72.77	20.598' LT	TOPO SURVEY POINT, PIN
2	2062982.0470	2388201.5790	880.7920	STE73	481+76.18	26.404' LT	TOPO SURVEY POINT, PIN
3	2063517.1660	2388231.9230	883.2270	STE73	487+10.18	19.5707' RT	TOPO SURVEY POINT, PIN
4	2063988.4570	2388178.8730	897.3540	STE73	491+82.82	19.6789' LT	TOPO SURVEY POINT, PIN
90409	2074889.3602	2387247.1935	909.8153	STE73	600+96.06	743.8819' LT	PHOTO CONTROL H. & V., PIN
65723029	2029095.6320	2388863.9566	857.8368	STE73	142+81.29	38.3929' LT	DIST NTRK MON., PERM SRVY MRKR

REFERENCE TIES

POINT	CHAIN	STATION	OFFSET	DESCRIPTION
500	STE73	477+98.0595	33.8084' RT	POWER POLE, SHINER
501	STE73	475+61.5128	32.9954' RT	POWER POLE, SHINER
502	STE73	481+51.8066	19.1905' LT	GUARDRAIL STEEL PLATE BEAM, END
503	STE73	481+54.6310	18.4751' RT	GUARDRAIL STEEL PLATE BEAM, END
504	STE73	482+72.9120	33.2526' RT	POWER POLE, SHINER
505	STE73	487+40.6192	33.4883' RT	POWER POLE, SHINER
506	STE73	487+10.0035	40.4438' RT	FENCE POST, SHINER
507	STE73	487+00.6269	18.3707' RT	GUARDRAIL STEEL PLATE BEAM, END
508	STE73	491+65.3422	35.4306' LT	FENCE POST, SHINER
509	STE73	491+09.6572	35.6373' LT	FENCE POST, SHINER
510	STE73	491+36.0914	32.9686' RT	POWER POLE WITH TRANSFORMER, SHINER

CURVE POINT NUMBERS

CHAIN	CURVE	PI	CC	PC	PT
STE73	270	270	271	272	273
STE73	210	210	211	212	213
STE73	220	220	221	222	223
STE73	230	230	231	232	233
STE73	240	240	241	242	243
STE73	250	250	251	252	253
STE73	260	260	261	262	263
STE73	280	280	281	282	283
STE73	290	290	291	292	293
STE73	300	300	301	302	303
STE73	310	310	311	312	313
STE73	320	320	321	322	323

BENCH MARKS

POINT	NORTH	EAST	ELEVATION	CHAIN	STATION	OFFSET	DESCRIPTION
402	2063080.9007	2388257.7459	885.2138	STE73	482+73.35	32.6288' RT	BENCH TIE, POWER POLE
403	2063476.5224	2388252.6979	881.2945	STE73	486+68.95	39.1486' RT	CHISELED SQUARE, WALL
419	2064658.2083	2388212.7159	887.4941	STE73	498+51.30	33.7291' RT	RAIL ROAD SPIKE, POWER POLE