

# INFORMATIONAL WARNING SIGN (FOR NARROW TRAVEL LANES)

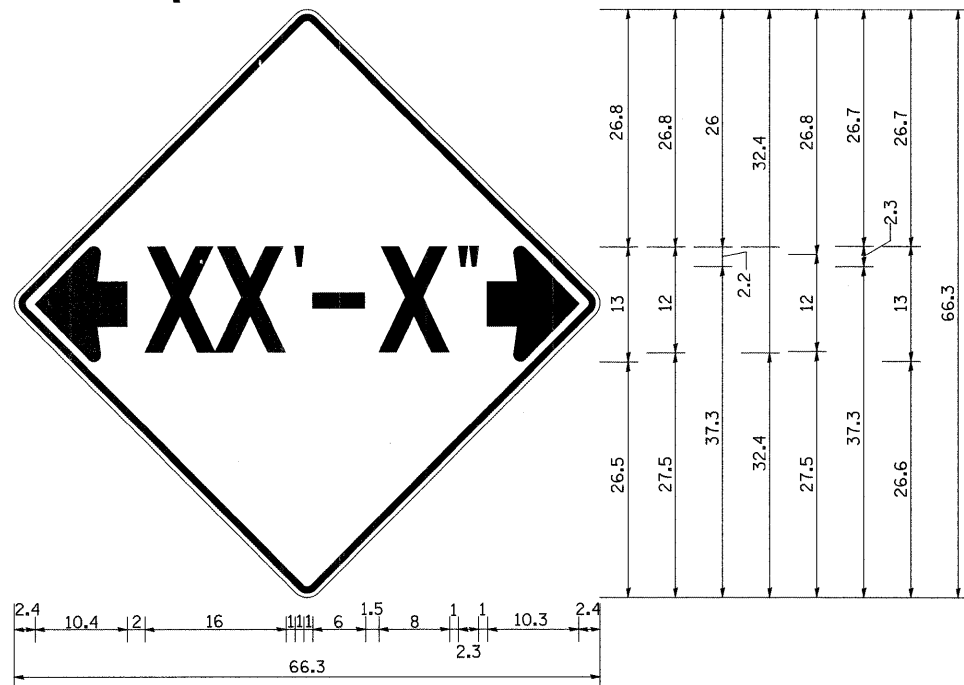

**NOTES**  
 W12-2 - Horizontal Clearance Sign  
 48.0" across sides, 1.9" Radius,  
 0.8" Border, 0.5" Indent, Black on  
 Orange; Standard Arrow Custom  
 10.4" X 8.1" 180° Black 11 Inch  
 D Series Lettering; Standard Arrow  
 Custom 10.4" X 8.1" 0°

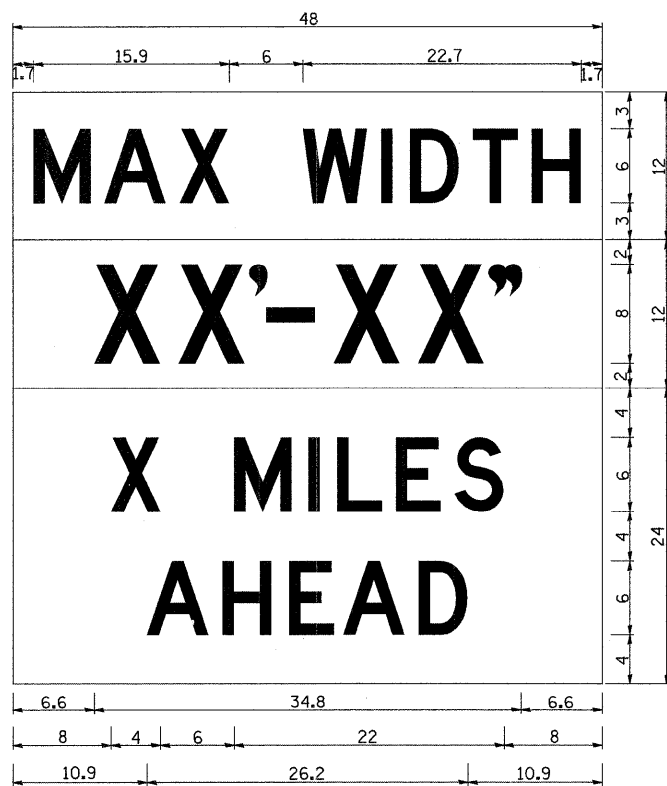

W12-1103 (Width Is 8D);  
 No border, Black on White;  
 [MAX WIDTH] D;

No border, Black on Orange;  
 [XX'-XX''] D;

No border, Black on White;  
 [X MILES] D; [AHEAD] D;

All work to furnish and install these signs shall be included in the cost of the Traffic Control Standards and shall not be paid for separately.

ALL DIMENSIONS ARE IN INCHES UNLESS OTHERWISE NOTED.

REVISED - 1-9-08

# HOT-MIX ASPHALT APPROACHES & MAILBOX RETURNS FOR TWO LIFT (3P) RESURFACING PROJECTS

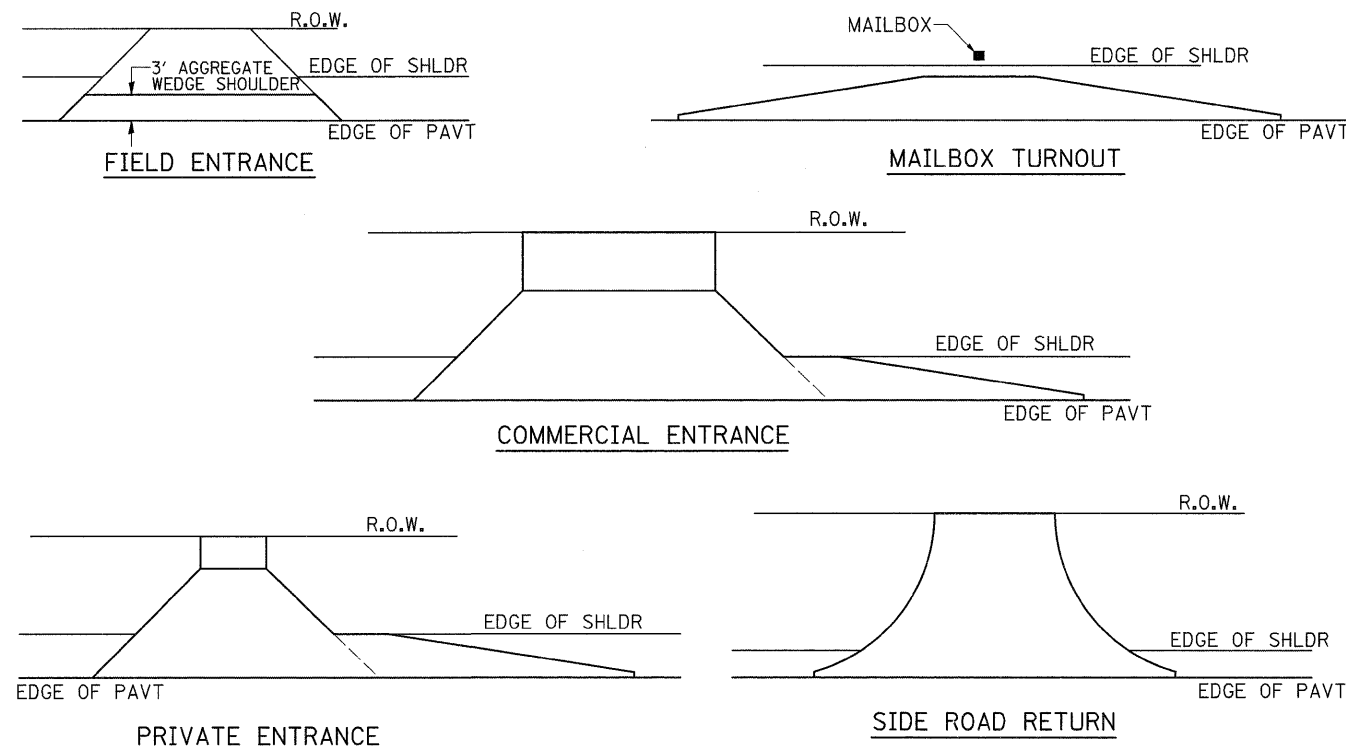

**NOTE:** EXISTING HMA PE's, CE's, SR's, & MB TURNOUTS  
 Place 2 1/4 " Incidental Hot-Mix Asphalt Surfacing #40800050 on entrance to conform to the existing configuration.

EXISTING AGG. PE's & CE's  
 Place 2" Incidental Hot-Mix Asphalt Surfacing #40800050 on existing entrance to conform to the present configuration.

EXISTING AGG. SIDEROADS  
 Place 3" Incidental Hot-Mix Asphalt Surfacing #40800050 on sideroad to conform to the present configuration.

EXISTING AGG. MAILBOX TURNOUTS  
 Existing Agg. Mailbox Turnouts shall be constructed as shown below.

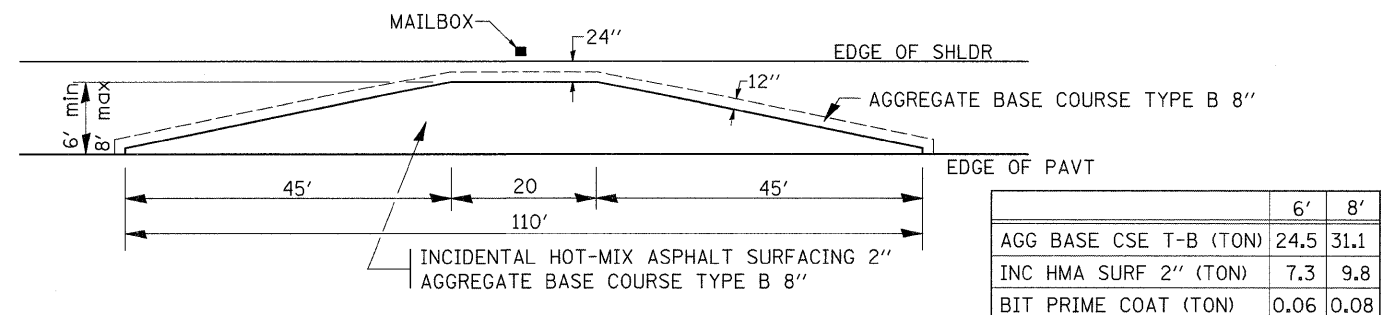

	6'	8'
AGG BASE CSE T-B (TON)	24.5	31.1
INC HMA SURF 2" (TON)	7.3	9.8
BIT PRIME COAT (TON)	0.06	0.08

REVISION	DATE	DESCRIPTION
REVISED -	2-1-08	
REVISED -		
REVISED -		
REVISED -		

SCALE: 50.0000' / IN SHEET NO. OF SHEETS STA. TO STA.

F.A.P. RTE.	SECTION	COUNTY	TOTAL SHEETS	SHEET NO.
654	(107, 108, 109)RS-4	STEPHENSON	89	73

CONTRACT NO. 64C91