

DESIGNER NOTES:
 1. Include State Standard 606001 for combination concrete curb and gutter details.
 2. Include State Standard 420001 for pavement joints.
 3. Include District CADD Standard for frame and grates and specify grate type in plans.
 4. Include District Special Provision. Pay item includes transitional c.c.c & g., inlet and frame and grate. All work within pay limits.
 5. The designer should include pavement removal quantities when the apron requires pavement removal.

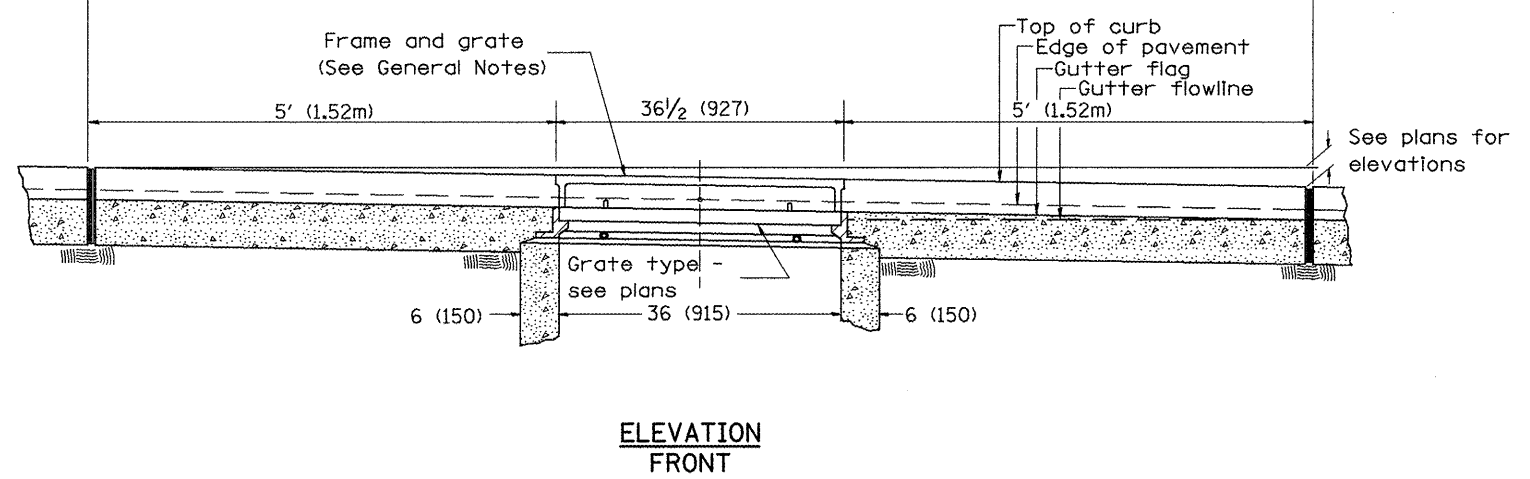
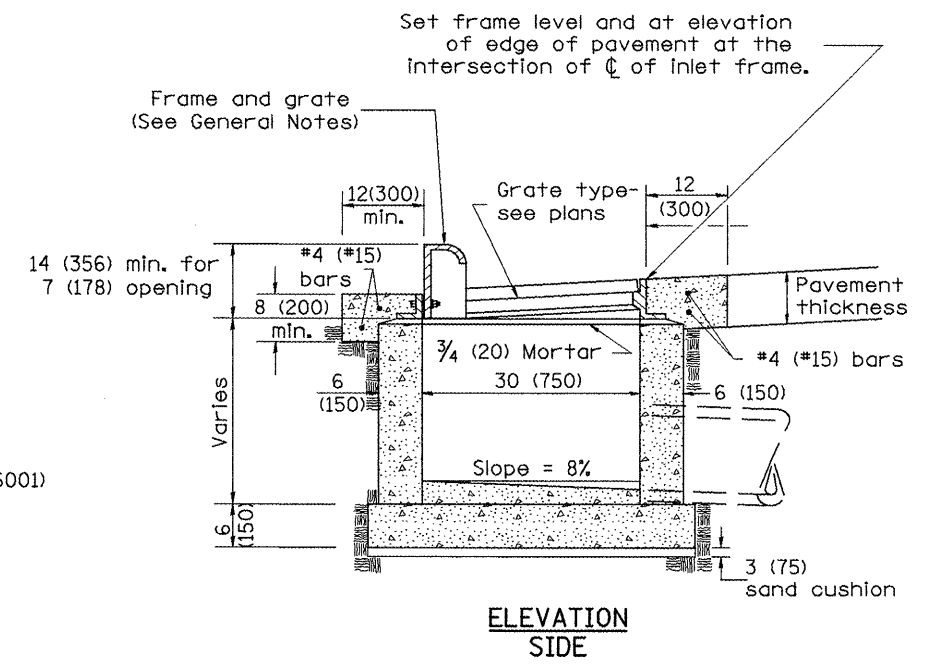
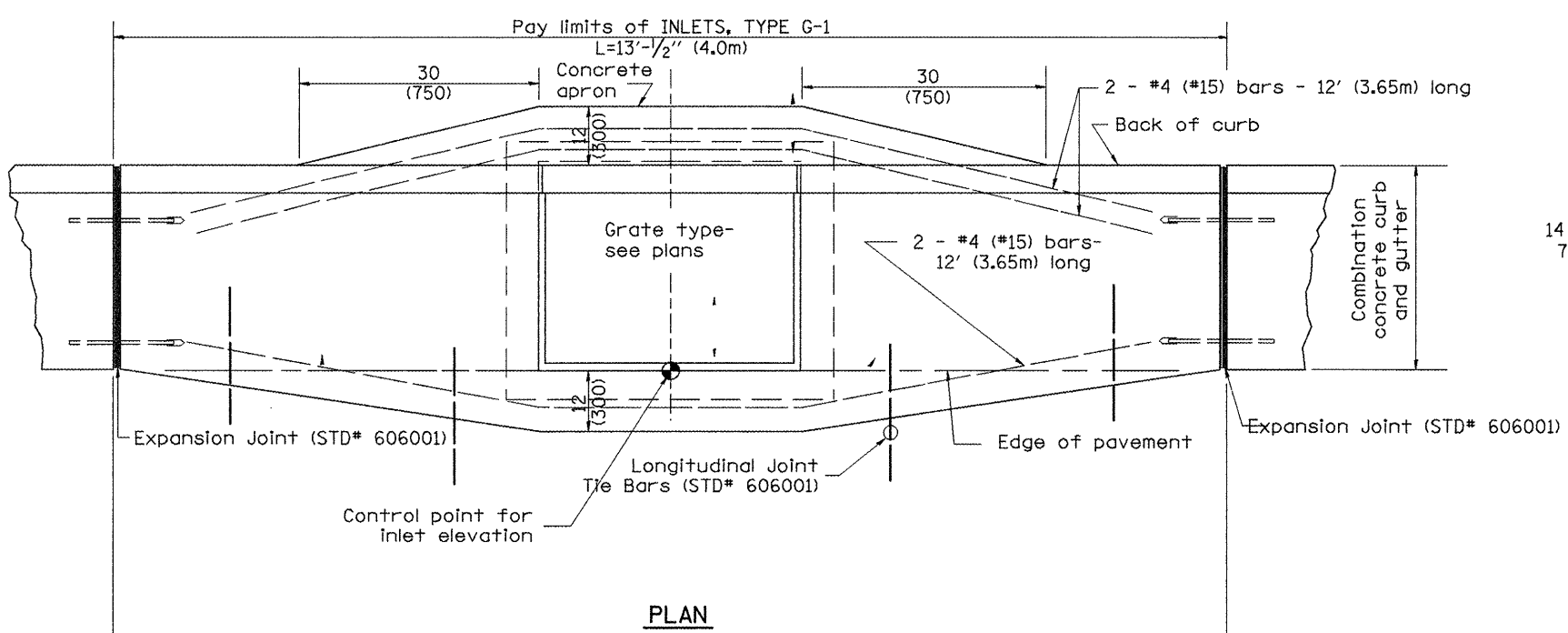

GENERAL NOTES

- Inlet construction shall be in accordance with Section 602 of the Standard Specifications.
- Combination Concrete Curb & Gutter shall be constructed in accordance with Section 606 of the Standard Specifications.
- See District CADD Standard 604001-D4 for frame and grates.

All dimensions are in inches (millimeters) unless otherwise noted.

01-01-97	RENUM. B-4.01, NEW REVISION BOX	T.P.
10-99	REVISION TO GENERAL NOTES	J.A.
02-00	REVISION TO DESIGNER NOTES	J.A.
10-16-06	REVISED TO 2007 SPEC.	M.A.

**STATE OF ILLINOIS
DEPARTMENT OF TRANSPORTATION**

INLETS, TYPE G-1

NOT TO SCALE

F.A.P. RTE.	SECTION	COUNTY	TOTAL SHEETS	SHEET NO.
399	36R-8	Tazewell	429	194
CONTRACT NO. 68258				