

WB STA. 1205+18 - 1205+20 2'
WB STA. 1299+00 - 1300+00 100'

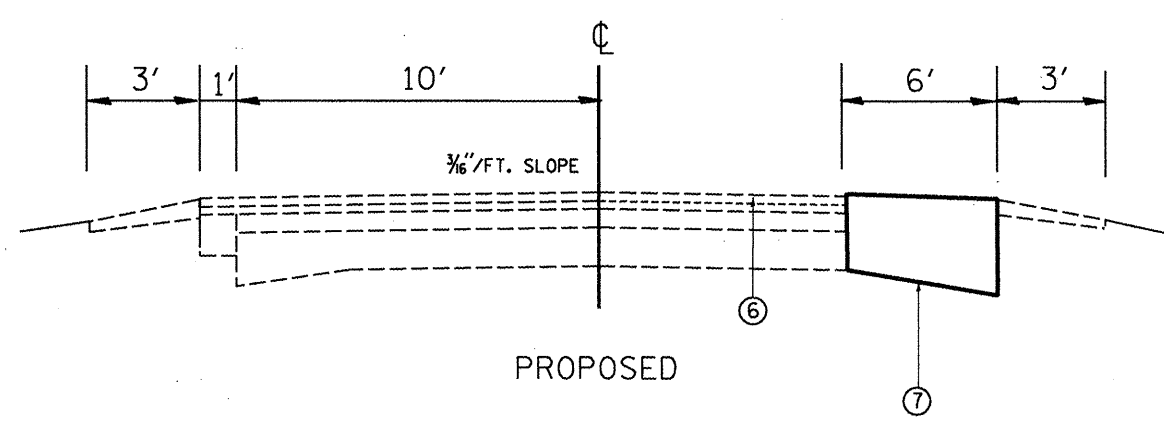
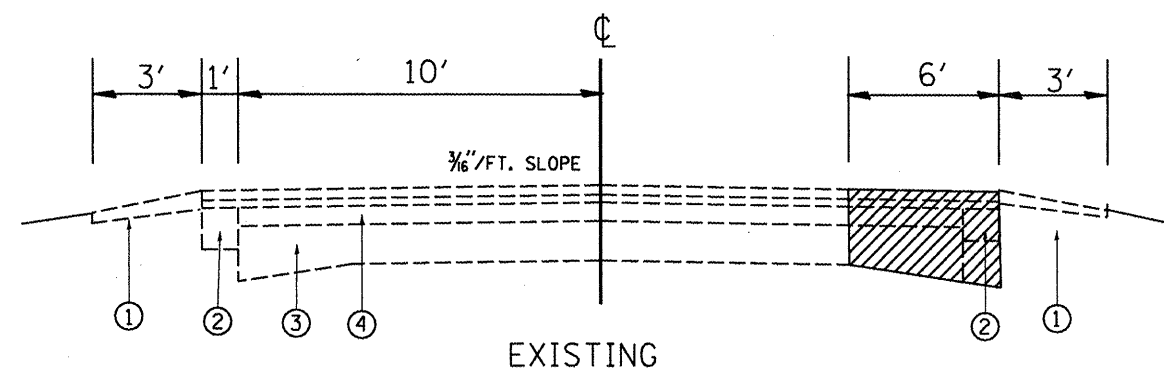

EB STA. 1202+30 - 1202+65 35'
EB STA. 1298+75 - 1299+50 75'

NOTE: If there is stationing with in the patch it shall be replaced.

NOTE: The top 2" nominal of all patches shall be constructed using a HMA surface course as specified in the Bituminous Concrete Mixture Requirements table.

- ① EXIST. AGG. SHLDR. TYPE B
- ② EXIST. STAB. SHLDR. 6"
- ③ EXIST. PCC PAV'T. 9"-6"-9"
- ④ EXIST. BIT. OVERLAY
- ⑤ EXIST. CONC. GUTTER TYPE A
- ⑥ EXIST. BCSC, SUPERPAVE, MIX D, N50, 1 1/2"
- ⑦ PROP. HMA CLASS D PATCH, TYPE I-IV 10"

FILE NAME = 68333.dgn	USER NAME = oppenzeller,jj	DESIGNED -	REVISED -
		DRAWN -	REVISED -
		CHECKED -	REVISED -
		DATE -	REVISED -

**STATE OF ILLINOIS
DEPARTMENT OF TRANSPORTATION**

TYPICAL SECTIONS			
SCALE:	SHEET NO.	OF SHEETS	STA. TO STA.

F.A.P. RTE.	SECTION	COUNTY	TOTAL SHEETS	SHEET NO.
612	(109D)	FULTON	19	6
CONTRACT NO. 68842			ILLINOIS FED. AID PROJECT	