

STATE OF ILLINOIS
DEPARTMENT OF TRANSPORTATION

BEAM REACTIONS

R _L	(kN)	74.7
R _R	(kN)	134.8
Imp.	(kN)	55.6
R (Total)	(kN)	265.1

Notes:
Diaphragm removal and reinstallation may be required to facilitate drilling holes. Cost included with Furnishing and Erecting Structural Steel.
New steel extensions, shim plates and connection bolts are included with Furnishing and Erecting Structural Steel. Prior to ordering any material, the Contractor shall verify in the field all bearing height and shim thickness dimensions. Min. Jack capacity = 255 kN.
Anchor bolts shall be ASTM F1554 all-thread (or an Engineer-approved alternate material) of the grade(s) and diameter(s) specified. ASTM A307 Grade C anchor bolts may be used in lieu of ASTM F1554 Grade 250 (F_y=248MPa). The corresponding specified grade of AASHTO M314 anchor bolts may be used in lieu of ASTM F1554.
Anchor bolts for Type II bearings shall be placed in holes drilled through the bottom bearing plate after members are in place. Side retainers shall be placed after bolts are installed.
Drilled and set anchor bolts shall be installed according to Article 521.06 of the Standard Specifications. Side retainers shall be included in the cost of Elastomeric Bearing Assembly, Type II.
The 3mm TFE sheet shall be bonded directly to the top steel plate with a two-component, medium viscosity epoxy resin, conforming to the requirements of the Federal Specification MMM-A-134, Type I. The bond agent shall be applied on the full area of the contact surfaces.
Bonding of 3mm TFE sheet during vulcanizing process will be permitted provided the process and method of adjusting assembly height is approved by the Engineer.

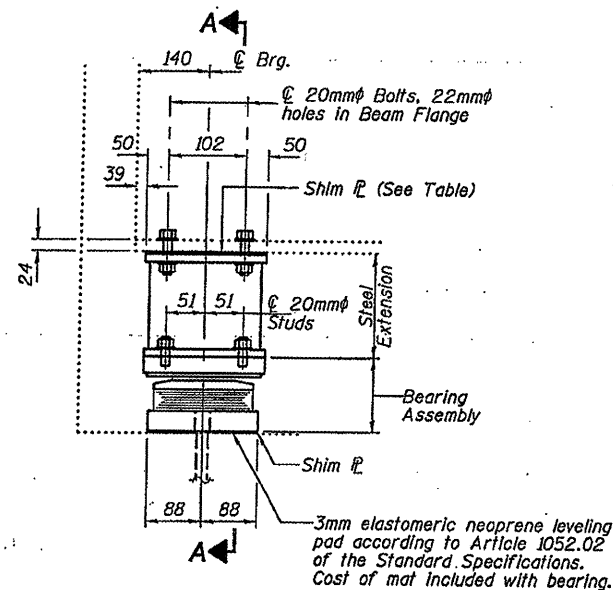

ELEVATION AT ABUTMENT

TYPE II TFE ELASTOMERIC EXP. BRG.

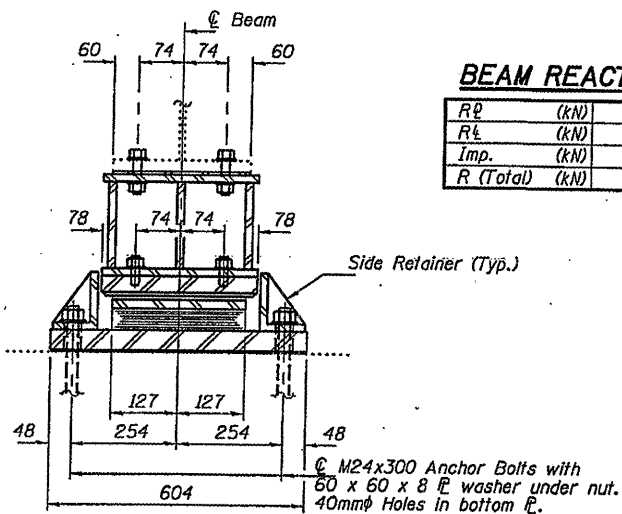

SECTION A-A

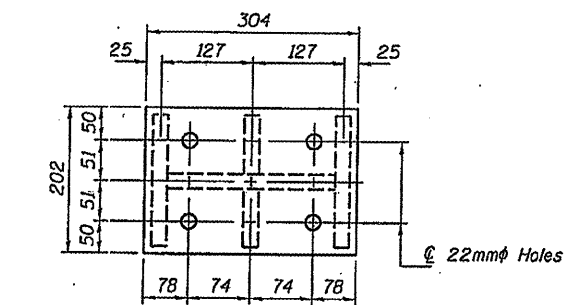

PLAN TOP AND BOTTOM PLATE

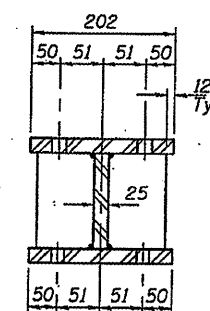

SECTION B-B

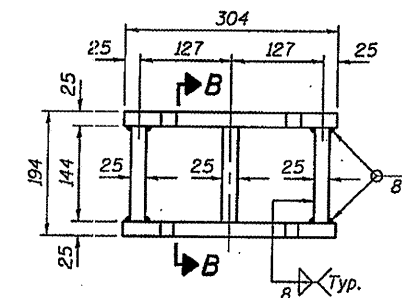

STEEL EXTENSION DETAIL

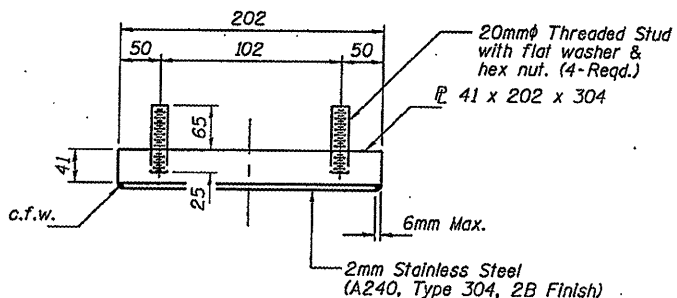

TOP BEARING ASSEMBLY

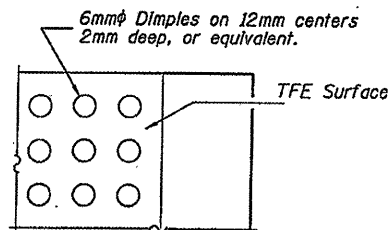

PLAN-TFE SURFACE

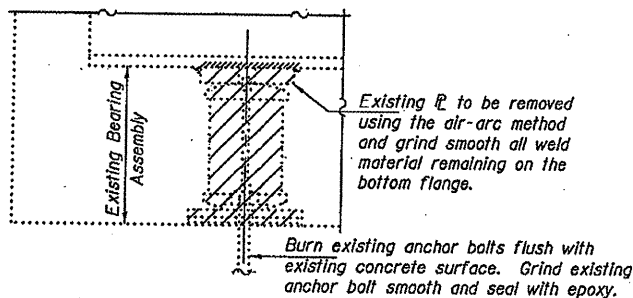

EXISTING BEARING REMOVAL DETAIL

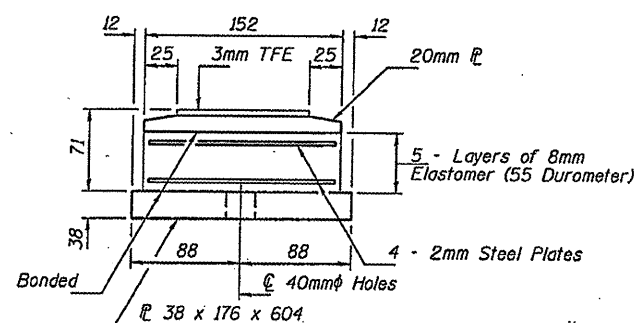

BOTTOM BEARING ASSEMBLY

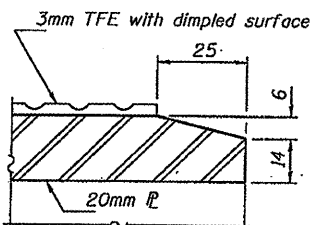

SECTION THRU TFE

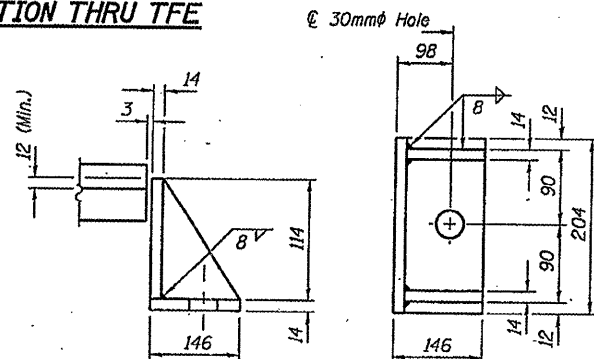

SIDE RETAINER

Equivalent rolled angle with stiffeners will be allowed in lieu of welded plates.

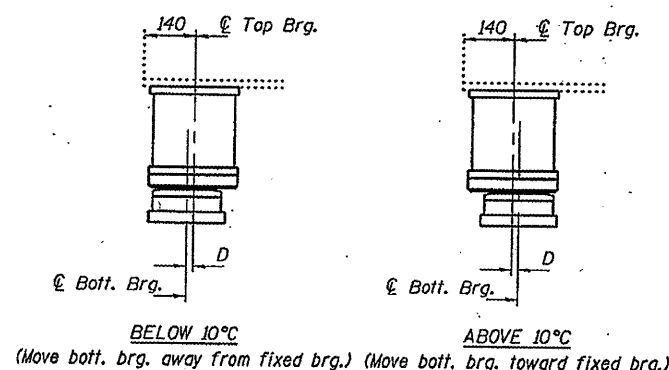

SETTING ANCHOR BOLTS AT EXP. BRG.

D = 1mm per each 10m of expansion for every 8°C temp. change from the normal temp. of 10°C.

SHIM PLATES

SN	Beam	Abut.	Thickness
057-0024	P	East	32
057-0024	Q	West	19

BILL OF MATERIAL

Item	Unit	Total
Elastomeric Bearing Assembly, Type II	Each	61
Jack and Remove Existing Bearings	Each	61
Furnishing and Erecting Structural Steel	kg	2860
Anchor Bolts, M24	Each	122

BEARING REPLACEMENT DETAILS FOR ALL BEAMS EXCEPT BEAM H
F.A.I. 55 OVER U.S. RTE. 51
SN 057-0024(NB) & 0025(SB)

DESIGNED	AJB
CHECKED	ATH
DRAWN	Kyle M. Steffen
CHECKED	AJB ATH

NOVEMBER 18, 2008
EXAMINED *Carl Perry*
PASSED *Ralph E. Anderson*
ENGINEER OF STRUCTURAL SERVICES
ENGINEER OF BRIDGES AND STRUCTURES

TYII/REPS 11-01-2006

REVISOR SHEET
12/23/08

SHEET NO. 2	F.A.I. RTE. 55	SECTION (57-4)H3R-5 RVBR-1 R57-2HB-1	COUNTY MCLEAN	TOTAL SHEETS 70	SHEET NO. 50
3 SHEETS	CONTRACT NO. 70661		FED. ROAD DIST. NO. ILLINOIS FED. AID PROJECT		