

\* Granular or solid flux filled headed studs conforming to Article 1006.32 of the Std. Specs., automatically end welded.

\*\* When joint is fixed, dimension is set at 1 1/2".

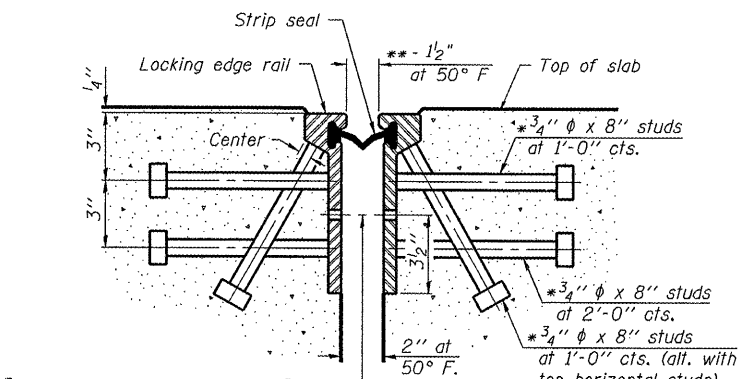

7/16" φ holes at 4'-0" cts. for 3/8" φ bolts. All bolts shall be burned, sawed, or chipped off flush with the plates after forms are removed, typ.

**SECTION THRU ROLLED RAIL JOINT**

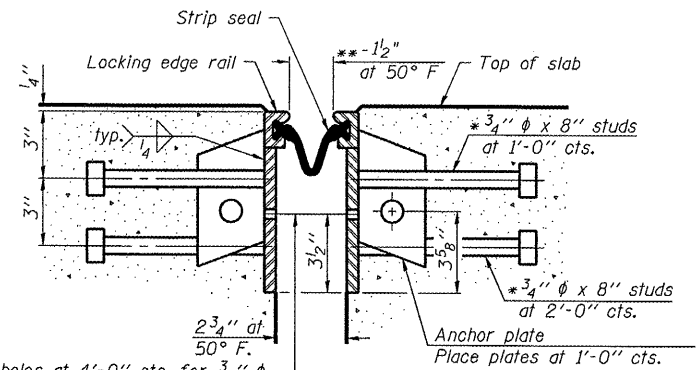

7/16" φ holes at 4'-0" cts. for 3/8" φ bolts. All bolts shall be burned, sawed, or chipped off flush with the plates after forms are removed, typ.

**SECTION THRU WELDED RAIL JOINT**

**Notes:**

The strip seal shall be made continuous and shall have a minimum thickness of 1/4". The configuration of the strip seal shall match the configuration of the Locking Edge Rails. Open or "webbed" strip seal gland configurations are not permitted. The gland shall be sized for a maximum rated movement of 4 inches.

The height and thickness of the Locking Edge Rails shown are minimum dimensions. The actual configuration of the Locking Edge Rails and matching strip seal may vary from manufacturer to manufacturer. Flanged edge rails will not be allowed. Locking Edge Rails may be spliced at slope discontinuities and stage construction joints.

The manufacturer's recommended installation methods shall be followed.

The joint opening and deck dimensions detailed on the superstructure are based on a rolled rail expansion joint. If the Contractor elects to use the welded rail expansion joint, the opening and deck dimensions shall be modified according to the dimensions detailed on this sheet. Required modifications shall be made at no additional cost to the State.

All steel components shall be galvanized after fabrication according to Article 520.03 of the Standard Specifications.

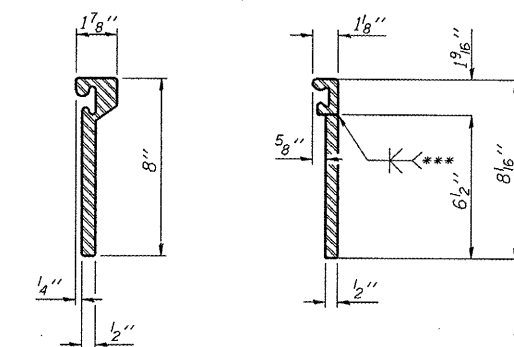

**ROLLED (EXTRUDED) RAIL**      **WELDED RAIL**

\*\*\* Back gouge not required if complete joint penetration is verified by mock-up.

**LOCKING EDGE RAIL SPLICE**

The inside of the locking edge rail groove shall be free of weld residue.

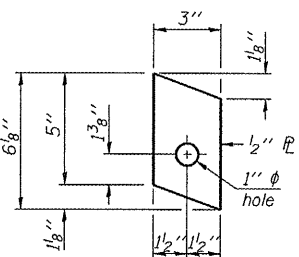

**ANCHOR PLATE (for welded rail)**

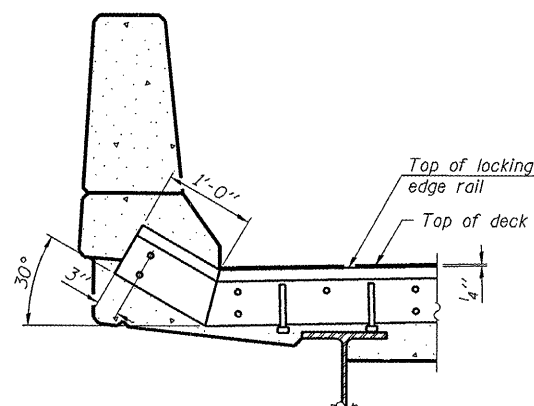

**AT PARAPET**

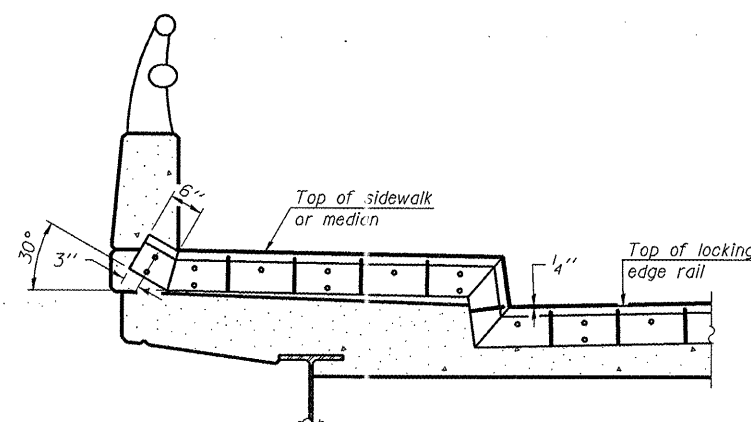

**AT SIDEWALK OR MEDIAN**

Shorter plates with a single row of studs at 12" cts. may be necessary on medians which are shallower than 9". See manufacturer's recommendation.

**LOCKING EDGE RAILS**

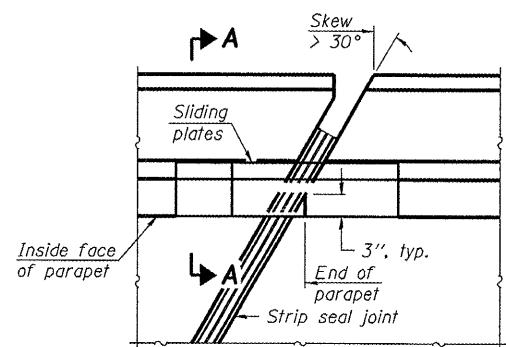

**PLAN**

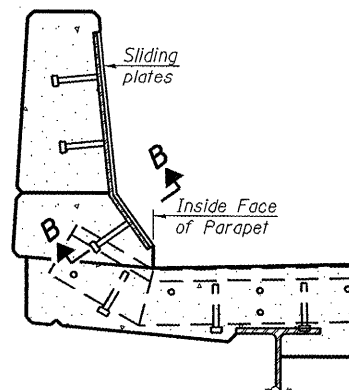

**SECTION A-A**

**POINT BLOCK DETAILS (for skews > 30°)**

**TYPICAL END TREATMENTS**

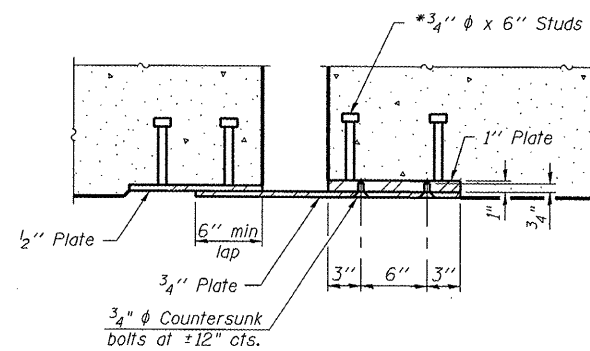

**SECTION B-B**

**BILL OF MATERIAL**

| Item                       | Unit | Total |
|----------------------------|------|-------|
| Preformed Joint Strip Seal | Foot | 232   |

ILLINOIS DEPARTMENT OF TRANSPORTATION

**EXPANSION JOINT DETAILS  
I 55 OVER MACOUPIN CREEK  
F.A.I. ROUTE 55 - SEC. 68-4B-1  
MONTGOMERY COUNTY  
STATION 1066+03.18  
STRUCTURE NO. 068-0038 N.B.  
STRUCTURE NO. 068-0039 S.B.**

DATE: 04-08  
REVISED:

DRAWN BY: MLO  
CHECKED BY: PBB

EJ-SSJ

11-1-06