

*Granular or solid flux filled headed studs conforming to Article 1006.32 of the Std. Specs., automatically end welded.

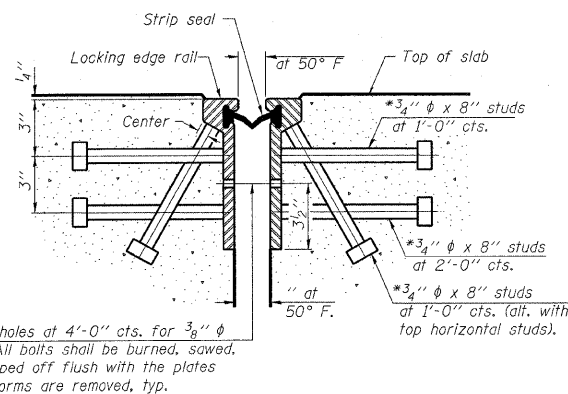

SECTION THRU ROLLED RAIL JOINT

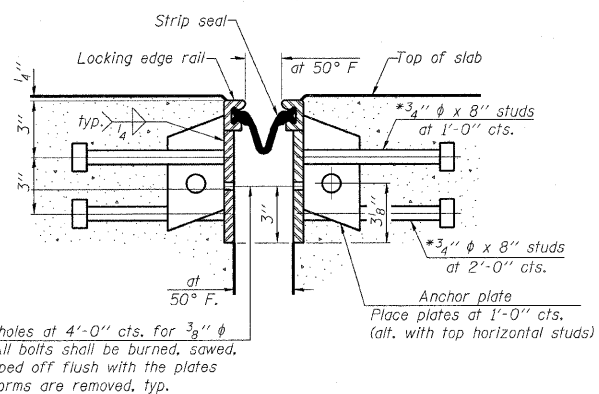

SECTION THRU WELDED RAIL JOINT

Notes:
 The strip seal shall be made continuous and shall have a minimum thickness of 1/4". The configuration of the strip seal shall match the configuration of the Locking Edge Rails. Open or "webbed" strip seal gland configurations are not permitted. The gland shall be sized for a maximum rated movement of 4 inches. The height and thickness of the Locking Edge Rails shown are minimum dimensions. The actual configuration of the Locking Edge Rails and matching strip seal may vary from manufacturer to manufacturer. Flanged edge rails will not be allowed. Locking Edge Rails may be spliced at slope discontinuities and stage construction joints. The manufacturer's recommended installation methods shall be followed. The joint opening and deck dimensions detailed on the superstructure are based on a rolled rail expansion joint. If the Contractor elects to use the welded rail expansion joint, the opening and deck dimensions shall be modified according to the dimensions detailed on this sheet. Required modifications shall be made at no additional cost to the State. All steel components shall be galvanized after fabrication according to Article 520.03 of the Standard Specifications.

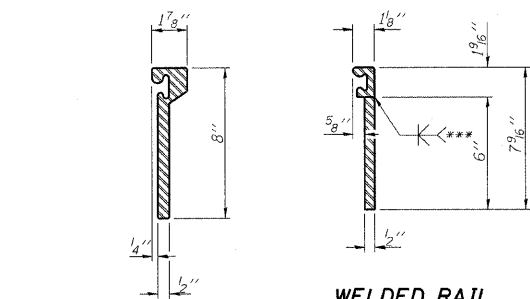

ROLLED EXTRUDED RAIL

WELDED RAIL

***Back gauge not required if complete joint penetration is verified by mock-up.

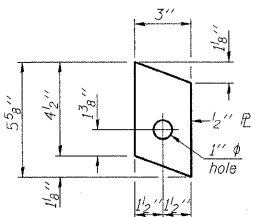

ANCHOR PLATE
(for welded rail)

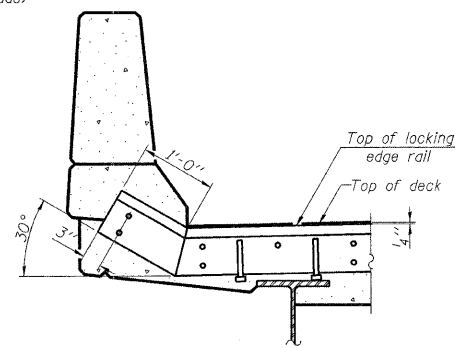

AT PARAPET

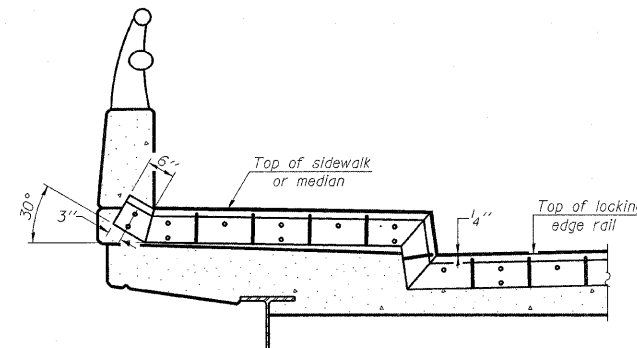

AT SIDEWALK OR MEDIAN

Shorter plates with a single row of studs at 12" cts. may be necessary on medians which are shallower than 9". See manufacturer's recommendation.

LOCKING EDGE RAIL SPLICE

The inside of the locking edge rail groove shall be free of weld residue.

LOCKING EDGE RAILS

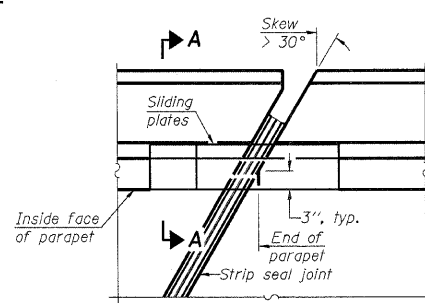

PLAN

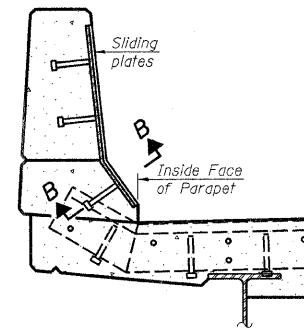

SECTION A-A

POINT BLOCK DETAILS
(for skews > 30°)

TYPICAL END TREATMENTS

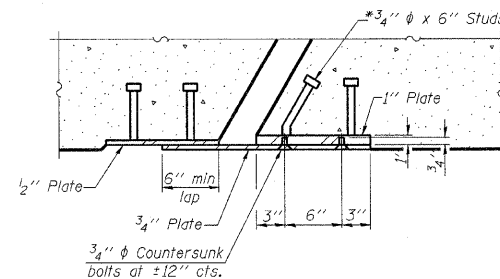

SECTION B-B

BILL OF MATERIAL

Item	Unit	Total	SN.
Preformed Joint Strip Seal	Foot	93	026-0005
Preformed Joint Strip Seal	Foot	93	026-0006

PREFORMED JOINT STRIP SEAL STRUCTURE NO.

EJ-SSJ

5-16-08

SHEET NO. 10
10 SHEETS

FILE NAME =	USER NAME = swartzw	DESIGNED -	REVISED -	STATE OF ILLINOIS DEPARTMENT OF TRANSPORTATION	PERFORMED JOINT STRIP SEAL SN. 026-0005 AND 026-0006	F.A.I. RTE.	SECTION	COUNTY	TOTAL SHEETS	SHEET NO.
ct:\pw\work\PW\DOT\SWARTZRW\dms36208\ch...	elidedesign_94993.dgn	DRAWN -	REVISED -			70	D-7 BRIDGE DECK REPAIRS	FAYETTE	59	33
PLOT SCALE = 28,00000 ' / IN.		CHECKED -	REVISED -			CONTRACT NO. 94993				
PLOT DATE = 10/17/2008		DATE -	REVISED -			FED. ROAD DIST. NO.	ILLINOIS FED. AID PROJECT			

SCALE: N/A SHEET NO. 10 OF 10 SHEETS STA. TO STA.