

CONTRACT NO. 97363

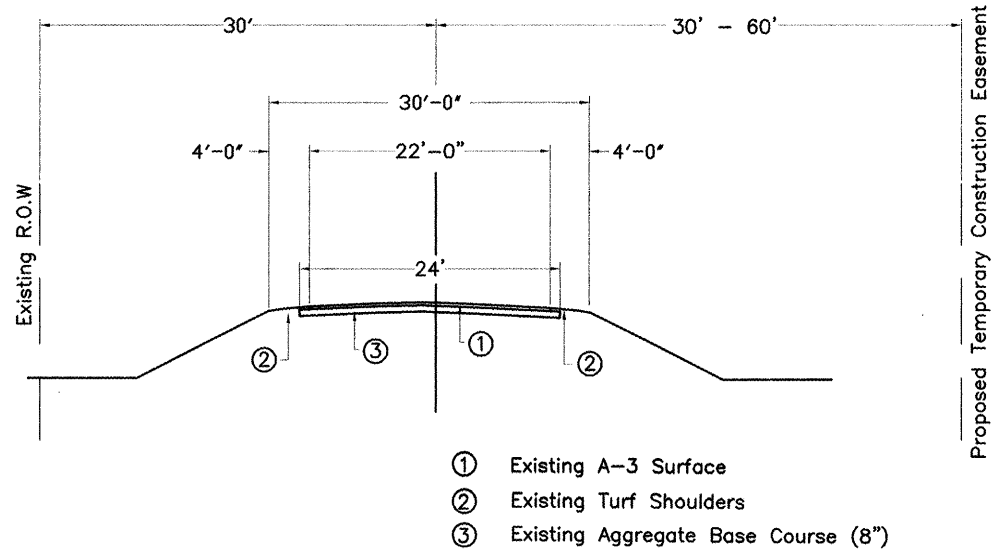

**EXISTING TYPICAL SECTION**

Sta. 104+45.33 To Sta. 106+00.56  
Sta. 106+51.56 To Sta. 109+08.10

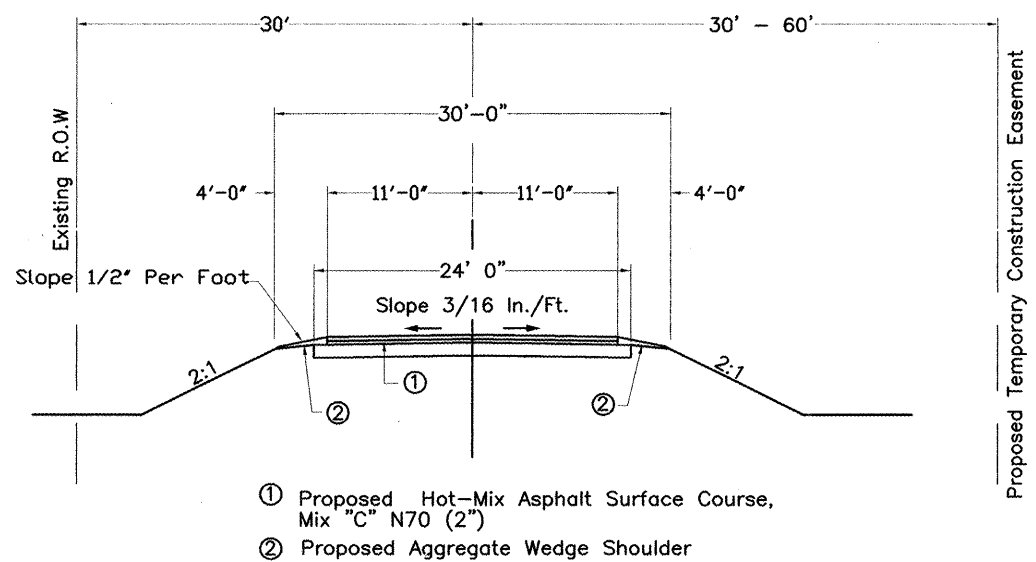

**PROPOSED TYPICAL SECTION**

Sta. 104+45.33 To Sta. 105+74.06  
Sta. 106+78.06 To Sta. 109+08.10

**QUANTITIES USED FOR ESTIMATING**

Bituminous Materials (Prime Coat) 0.07 Gal./Sq.Yd.

**SUMMARY OF QUANTITIES**

Bridge Construction Code - X081-2A

| Quantity | Unit   | Item  | Item Number |
|----------|--------|---|-------------|
| 852      | Cu Yd  | Channel Excavation                                  | 20300100    |
| 74       | Ton    | Porous Granular Embankment                          | 20700110    |
| 461      | Ton    | Stone Dumped Riprap, Class A4                       | 28100807    |
| 18       | Ton    | Aggregate Base Course, Type B                       | 35101400    |
| 62       | Gallon | Bituminous Material (Prime Coat)                    | 40600100    |
| 73       | Sq Yd  | Hot-Mix Asphalt Surface Removal - Butt Joint        | 40600982    |
| 138      | Ton    | Hot-Mix Asphalt Surface Course, Mix "C", N70        | 40603315    |
| 17       | Ton    | Aggregate Shoulders, Type B                         | 48101200    |
| 1        | L Sum  | Removal of Existing Structures                      | 50100200    |
| 27.8     | Cu Yd  | Concrete Structures                                 | 50300225    |
| 4.2      | Cu Yd  | Concrete Encasement                                 | 50300280    |
| 3140     | Pound  | Reinforcement Bars                                  | 50800105    |
| 205      | Foot   | Steel <b>Railing</b> , Type SM                      | 50901050*   |
| 450      | Foot   | Furnishing Steel Piles HP12X53                      | 51201600    |
| 450      | Foot   | Driving Piles                                       | 51202305    |
| 2        | Each   | Test Pile Steel HP12X53                             | 51203600    |
| 12       | Each   | Pile Shoes  | 51204650    |
| 1        | Each   | Name Plates   | 51500100    |
| 341      | Sq Yd  | Waterproofing Membrane System                       | 58100200    |
| 922      | Foot   | Portland Cement Mortar Fairing Course               | 58300100    |
| 2        | Each   | Traffic Barrier Terminal, Type 6A                   | 63100087*   |
| 2        | Each   | Traffic Barrier Terminal Type 1, Special (Tangent)  | 63100167*   |
| 1        | L Sum  | Mobilization  | 67100100    |
| 2        | Each   | Terminal Marker-Direct Applied                      | 78201000*   |
| 3073     | Sq Ft  | Precast Prestressed Concrete Deck Beams (42" Depth) | XX003515    |

\* Denotes Specialty Items.

**GENERAL NOTES**

- All Construction Signs shall be 48 inch Fluorescent Orange.
- Pavement Marking to be done by Others.