

CONTRACT NO. 97363

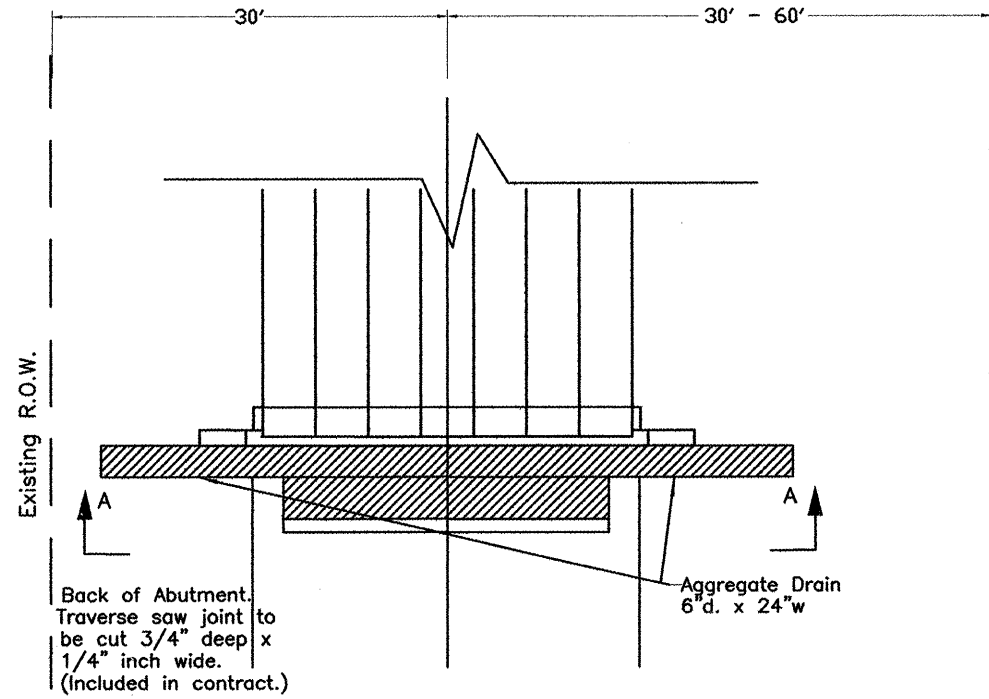

PLAN VIEW OF POROUS GRANULAR EMBANKMENT

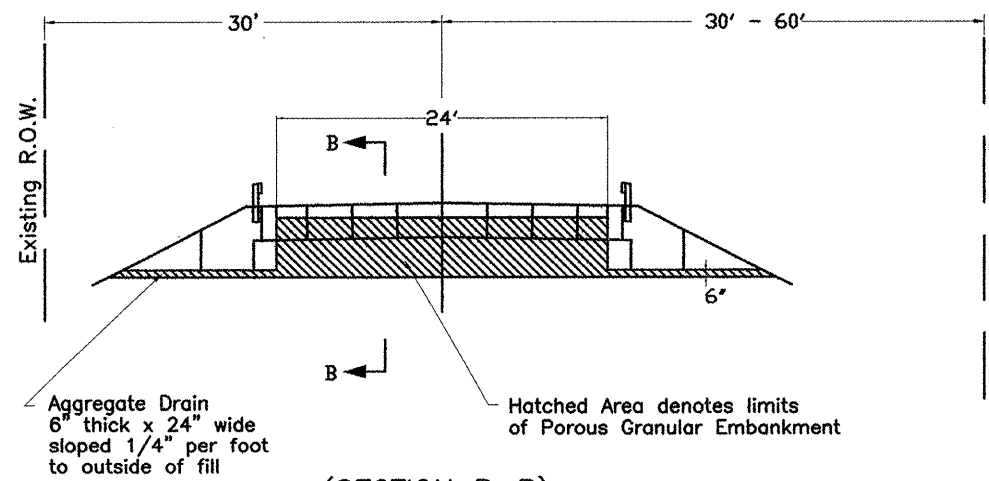

(SECTION B-B)
TYPICAL SECTION THRU
POROUS GRANULAR EMBANKMENT

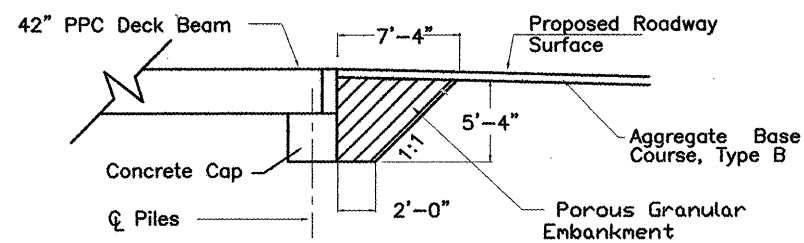

SECTION B-B

Location	Hot-Mix Asphalt Surface Ton	Channel Excavation Cu Yd	Stone Dumped Riprap Ton
Sta. 104+45.33 To Sta. 105+74.06	29		
Sta. 105+74.06 To Sta. 106+78.06	46	852	461
Sta. 106+78.06 To Sta. 109+08.10	63		
Total	138	852	461

MIXTURE REQUIREMENTS

Mixture use	Surface		
AC/PG	PG 64-22		
Rap % (Max)	0		
Design Air Voids	4.0% @ Ndes=70		
Mix Composition (Gradation Mixture)	9.5		
Friction Agg	Mixture C		

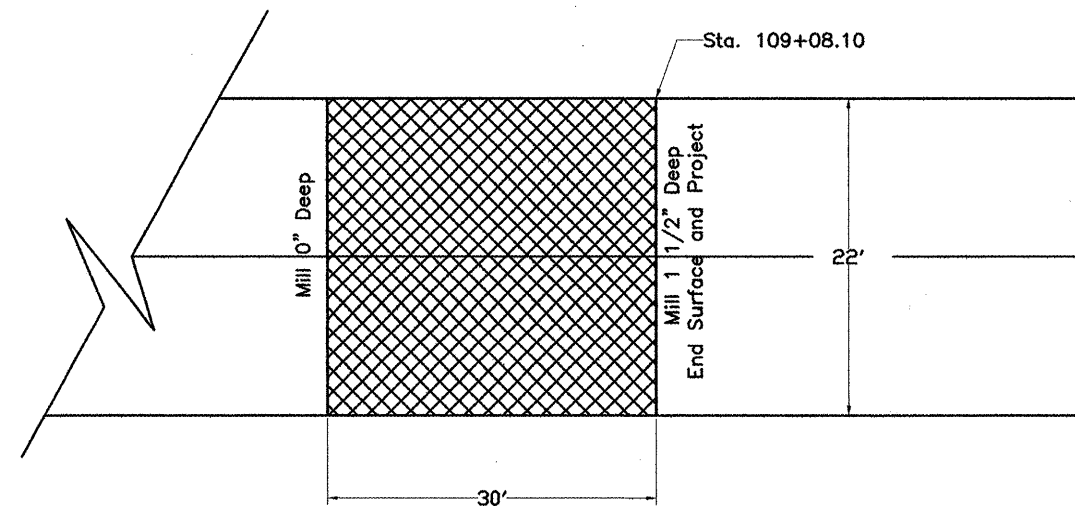

BUTT JOINT DETAIL