

ROUTE	COUNTY	SECTION	SHEET/OF
FAS 1857	RANDOLPH	99-00073-00-BR	1/11
FEDERAL AID PROJECT			
CONTRACT NO. 97363			

SHEET NO	INDEX OF SHEETS	CONTENT
1	Cover Sheet with Location Map	
2	Typical Sections, General Notes, Summary of Quantities	
3	Porous Granular Embankment Details and Pavement Schedule	
4	Plan and Profile	
5-11	Bridge Plans	

STATE OF ILLINOIS
DEPARTMENT OF TRANSPORTATION
PLANS FOR
PROPOSED LOCAL AGENCY IMPROVEMENT
RANDOLPH COUNTY
FAS 1857 (County Highway 7)
SECTION 99-00073-00-BR
PROJECT NO. BRS-1857(122)
JOB NO C-98-311-09
BRP PROGRAM

HIGHWAY STANDARDS:
BLR 21-8 515001-03
631032-04 701901-01

UTILITIES

Harrisonville Telephone Co. 618-939-6112
Village of Prairie Du Rocher 618-284-7171
New Wave Communications 888-863-9928
Ameren/IP 618-236-6210
JULIE
1-800-892-0123

Existing Structure: Single Span Bridge, 51' Long
Consisting of Cast in Place Concrete Deck and
Steel Stringers on Timber Piles. Structure No. 079-3071
Proposed Structure: Single Span, 104'-2" Long PPC
Deck Beam Bridge on Steel Piles. Structure No. 079-3072

DESIGN INFORMATION

Rural Collector
Class III Roadway
Design Speed 50 MPH
ADT (2008) - 950
(2018) - 1200

PAVEMENT DESIGN INFORMATION

Structural Design Traffic: 1200 (Year 2018) PV 1056
 SU 84
 MU 60

Minimum Soil Support IBR = 3
T.F. = 0.262 Eri = 3
Pavement Structure Materials: Surface: Hot-Mix Asphalt
 Base Course: Aggregate Type A

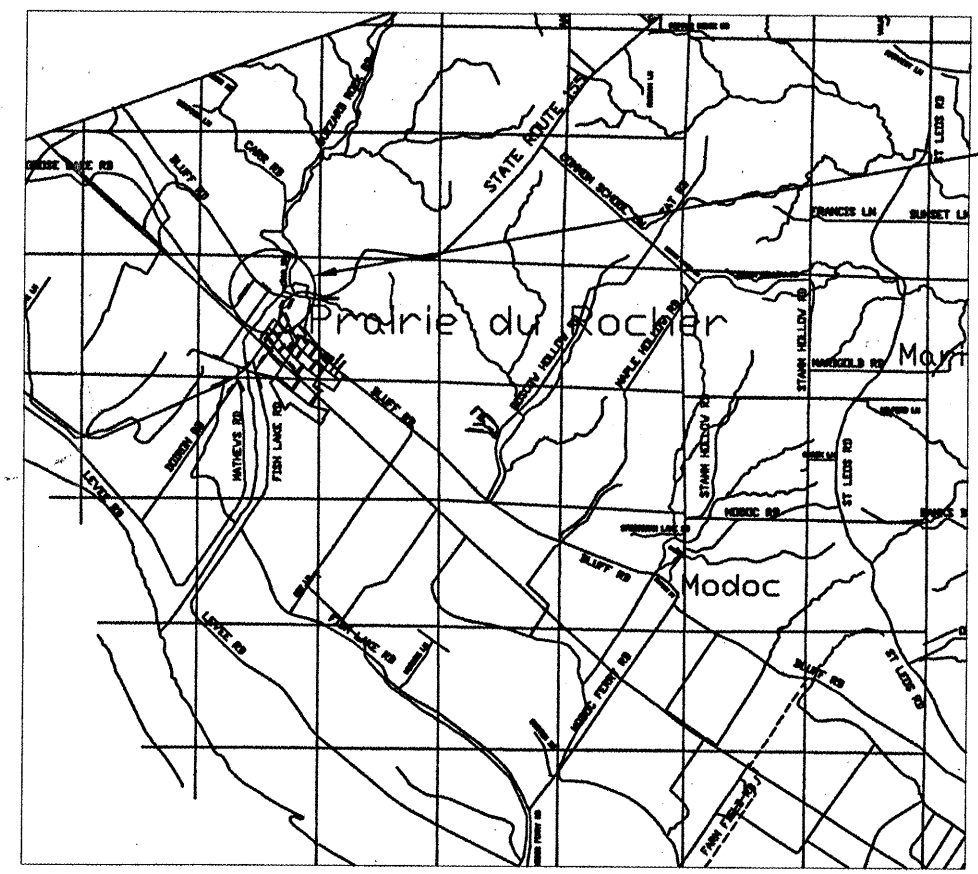
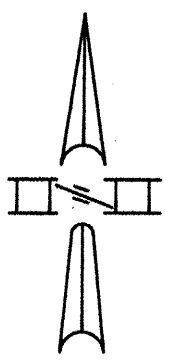

NET LENGTH OF IMPROVEMENT
462.77 LIN FT. = 0.0876 Miles

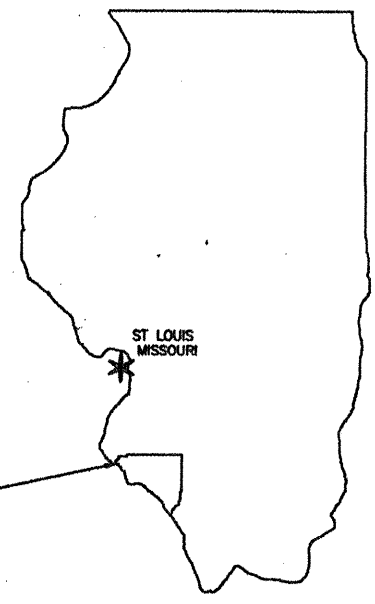

SITE OF PROPOSED IMPROVEMENT

PROPOSED IMPROVEMENT
STA. 104+45.33 TO 109+08.10

Michael Riebeling 12/09/2008
Engineer DATE
REGISTERED PROFESSIONAL ENGINEER
MICHAEL RIEBELING
062-044850
ILLINOIS
11/30/2009
EXPIRATION DATE

STATE OF ILLINOIS DEPARTMENT OF TRANSPORTATION	
Approved	December 9 2008 <i>Michael Riebeling</i> County Engineer
Passed	12/12/08 20 <i>[Signature]</i> District 8 Local Roads & Streets Engineer
Releasing for Bid Based on Limited Review	12/12/08 20 <i>[Signature]</i> Mary C. Larnie, P.E. Deputy Director of Highways

CONTRACT NO. 97363

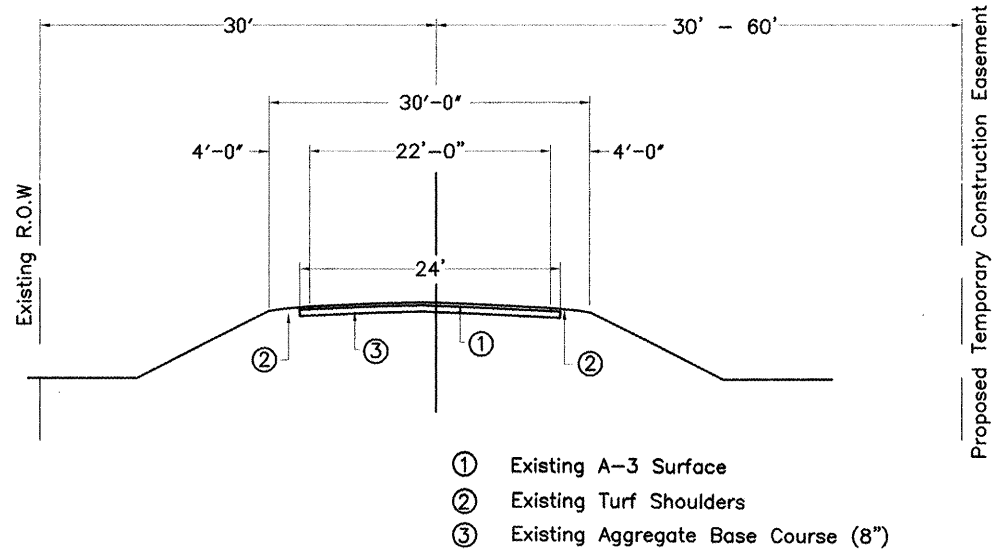

EXISTING TYPICAL SECTION

Sta. 104+45.33 To Sta. 106+00.56
 Sta. 106+51.56 To Sta. 109+08.10

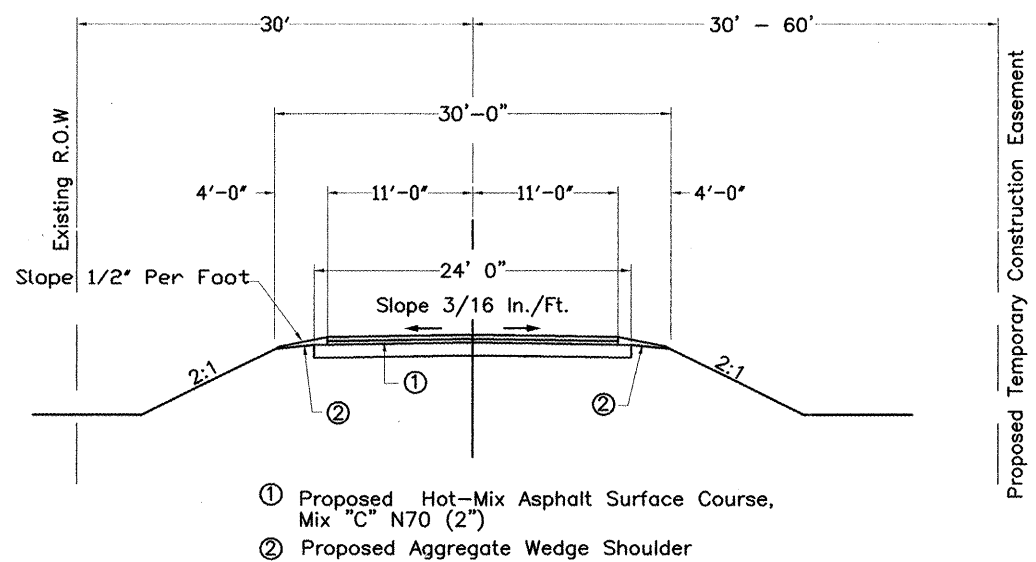

PROPOSED TYPICAL SECTION

Sta. 104+45.33 To Sta. 105+74.06
 Sta. 106+78.06 To Sta. 109+08.10

QUANTITIES USED FOR ESTIMATING

Bituminous Materials (Prime Coat) 0.07 Gal./Sq.Yd.

SUMMARY OF QUANTITIES

Bridge Construction Code - X081-2A

Quantity	Unit	Item	Item Number
852	Cu Yd	Channel Excavation	20300100
74	Ton	Porous Granular Embankment	20700110
461	Ton	Stone Dumped Riprap, Class A4	28100807
18	Ton	Aggregate Base Course, Type B	35101400
62	Gallon	Bituminous Material (Prime Coat)	40600100
73	Sq Yd	Hot-Mix Asphalt Surface Removal - Butt Joint	40600982
138	Ton	Hot-Mix Asphalt Surface Course, Mix "C", N70	40603315
17	Ton	Aggregate Shoulders, Type B	48101200
1	L Sum	Removal of Existing Structures	50100200
27.8	Cu Yd	Concrete Structures	50300225
4.2	Cu Yd	Concrete Encasement	50300280
3140	Pound	Reinforcement Bars	50800105
205	Foot	Steel Railing , Type SM	50901050*
450	Foot	Furnishing Steel Piles HP12X53	51201600
450	Foot	Driving Piles	51202305
2	Each	Test Pile Steel HP12X53	51203600
12	Each	Pile Shoes	51204650
1	Each	Name Plates	51500100
341	Sq Yd	Waterproofing Membrane System	58100200
922	Foot	Portland Cement Mortar Fairing Course	58300100
2	Each	Traffic Barrier Terminal, Type 6A	63100087*
2	Each	Traffic Barrier Terminal Type 1, Special (Tangent)	63100167*
1	L Sum	Mobilization	67100100
2	Each	Terminal Marker-Direct Applied	78201000*
3073	Sq Ft	Precast Prestressed Concrete Deck Beams (42" Depth)	XX003515

* Denotes Specialty Items.

GENERAL NOTES

1. All Construction Signs shall be 48 inch Fluorescent Orange.
2. Pavement Marking to be done by Others.

CONTRACT NO. 97363

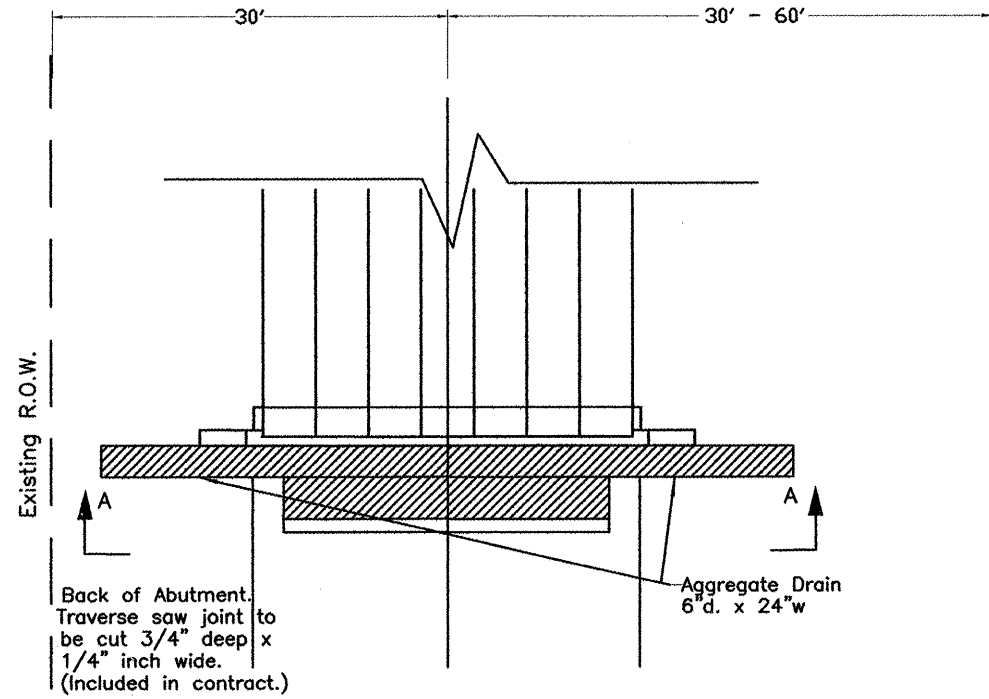

PLAN VIEW OF POROUS GRANULAR EMBANKMENT

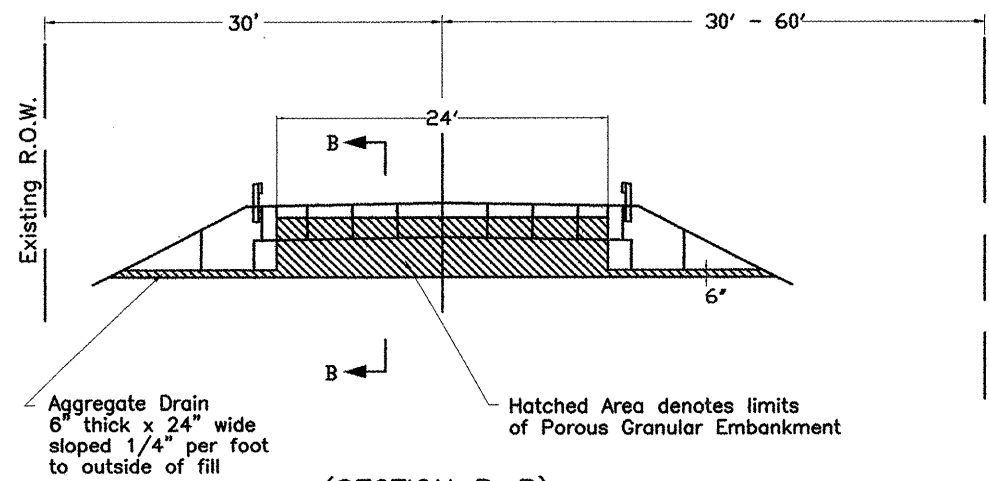

(SECTION B-B)
TYPICAL SECTION THRU
POROUS GRANULAR EMBANKMENT

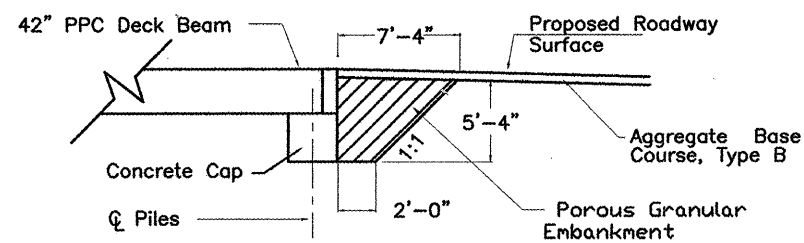

SECTION B-B

Location	Hot-Mix Asphalt Surface Ton	Channel Excavation Cu Yd	Stone Dumped Riprap Ton
Sta. 104+45.33 To Sta. 105+74.06	29		
Sta. 105+74.06 To Sta. 106+78.06	46	852	461
Sta. 106+78.06 To Sta. 109+08.10	63		
Total	138	852	461

MIXTURE REQUIREMENTS

Mixture use	Surface		
AC/PG	PG 64-22		
Rap % (Max)	0		
Design Air Voids	4.0% @ Ndes=70		
Mix Composition (Gradation Mixture)	9.5		
Friction Agg	Mixture C		

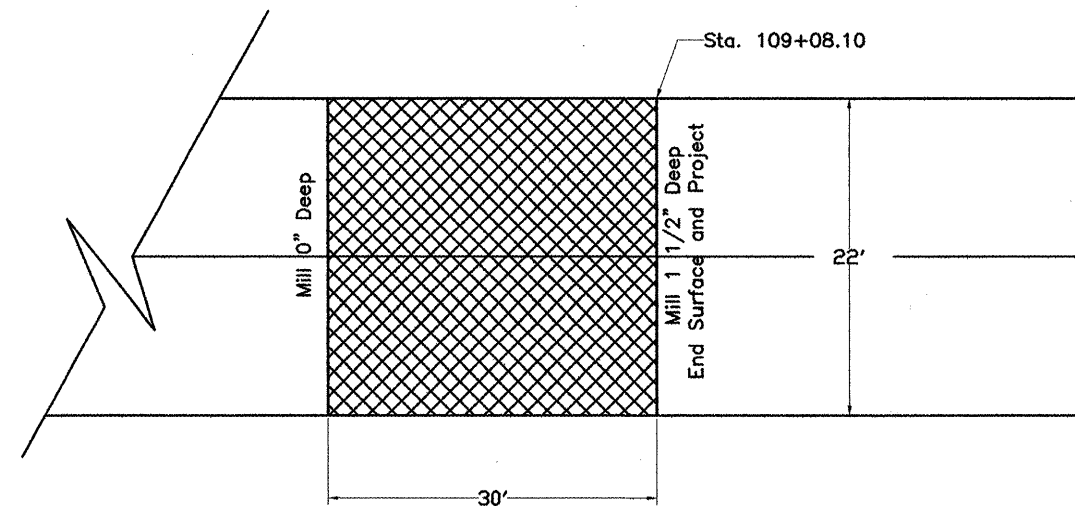

BUTT JOINT DETAIL

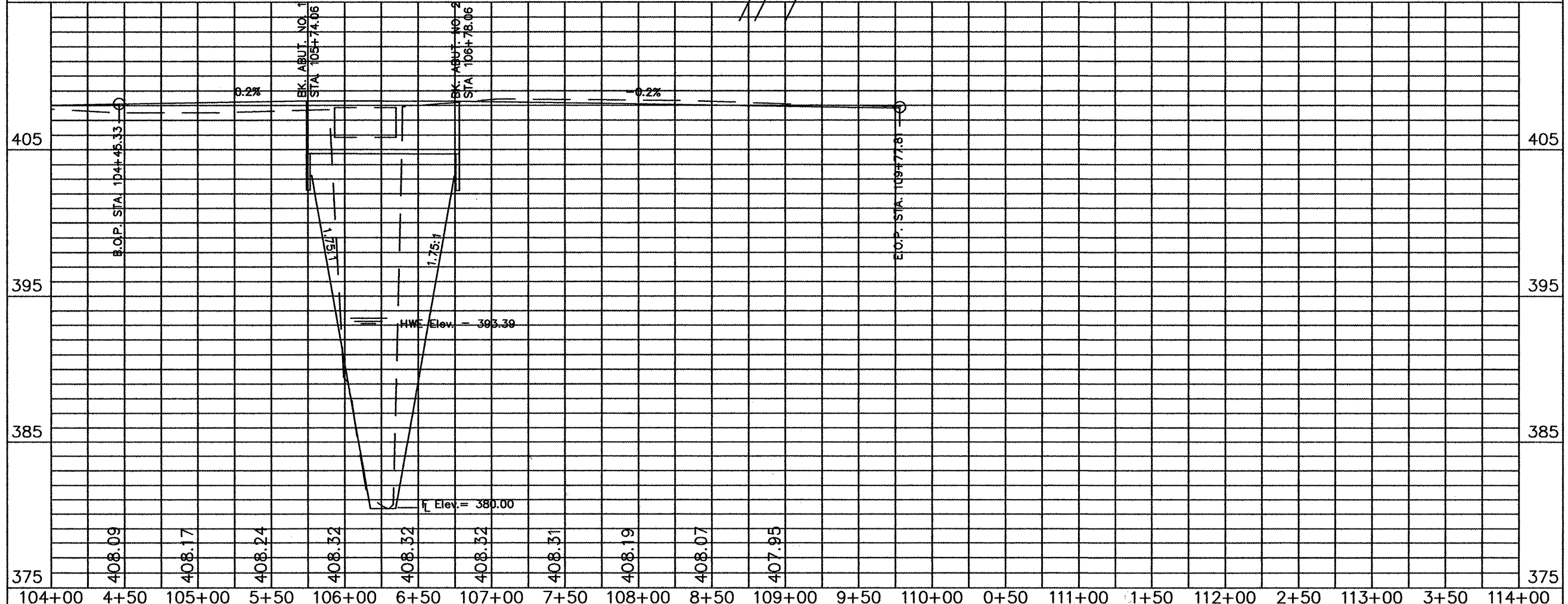
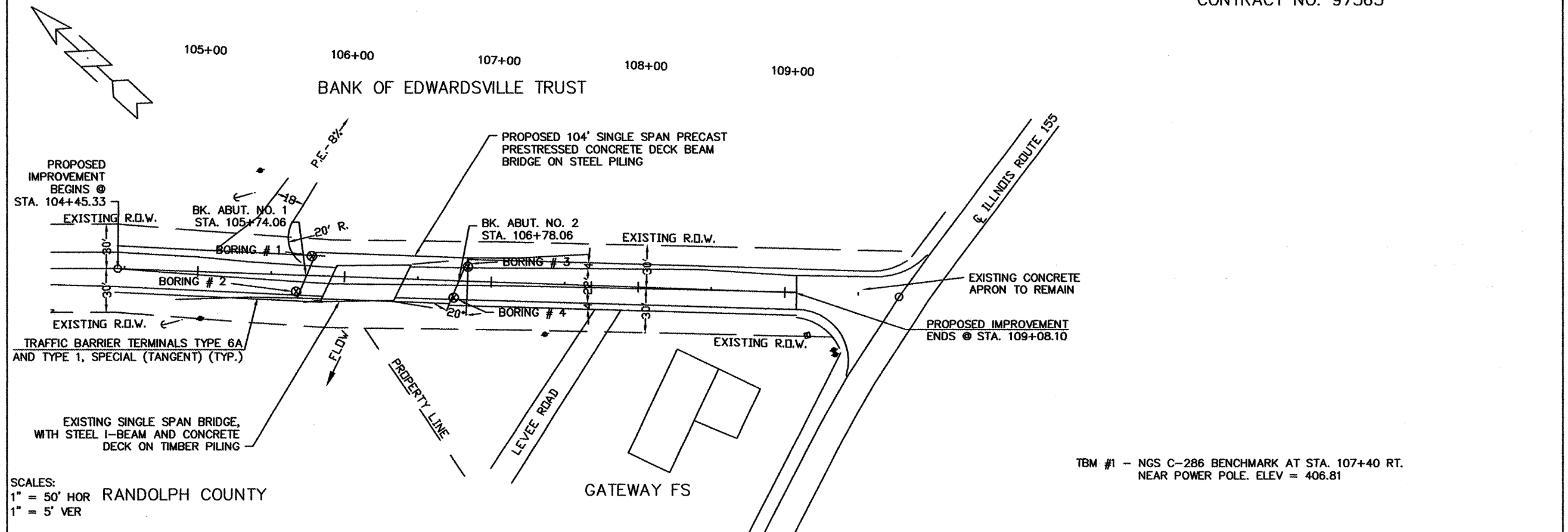

Plan and Profile Sta 104+00 to Sta 114+00

BM#1 - NGSC-286 Benchmark located near a Power Pole at Sta. 107+40 Rt. Elev. = 406.81

Existing Structure:
Single Span, 50 ft. long, 25 ft. wide
Steel I-Beam and Concrete Deck
Structure on Timber Piling.

Salvage - None

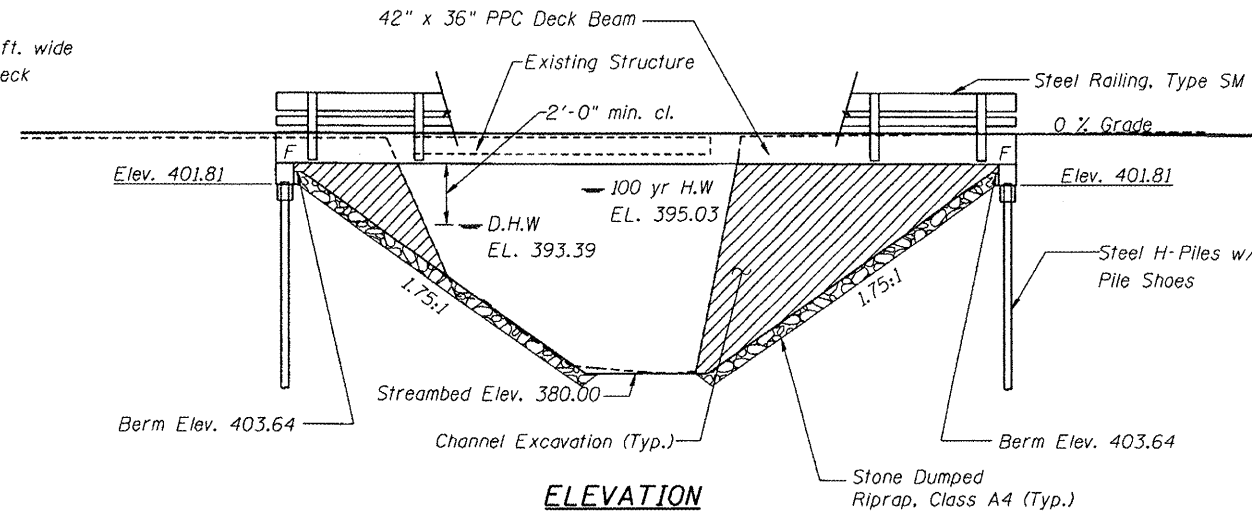

ELEVATION

GENERAL NOTES

- The Contractor shall drive test piles to 110% of the nominal required bearing specified in production locations of substructures specified or approved by the Engineer before ordering the remainder of piles. See Special Provisions for boring data.
- Reinforcement bars shall conform to the requirements of ASTM A706 Grade 60. See Special Provisions.
- Reinforcement bars designated (E) shall be epoxy coated.
- The top surface of the beams shall be finished according to the IDOT Manual for the Fabrication of Precast Prestressed Concrete Products.
- Excavation behind existing abutment walls shall be performed to balance front and back soil pressure before removing the existing superstructure.
- Layout of slope protection system may be varied in the field to suit ground conditions as directed by the Engineer.

- INDEX OF SHEETS**
- General Plan & Elevation
 - Superstructure
 - Deck Beam
 - Deck Beam Details
 - Steel Railing
 - Pile Bent Abutments
 - Pile Details

WATERWAY INFORMATION

Drainage Area = 7.65 SQ MI		Low Grade Elev = 407.20			Sta. 104+00				
Flood	Freq. Yr.	Q C.F.S.	Opening Sq.Ft.		Nat. H.W.E.	Head - Ft.		Headwater Elev.	
			Exist.	Prop.		Exist.	Prop.	Exist.	Prop.
Design	20	3828	403	515	393.39	0.87	0.11	394.26	393.50
Base	100	5912	484	621	395.03	1.76	0.36	396.79	395.39
Overtopping									
Max. Calc	500								

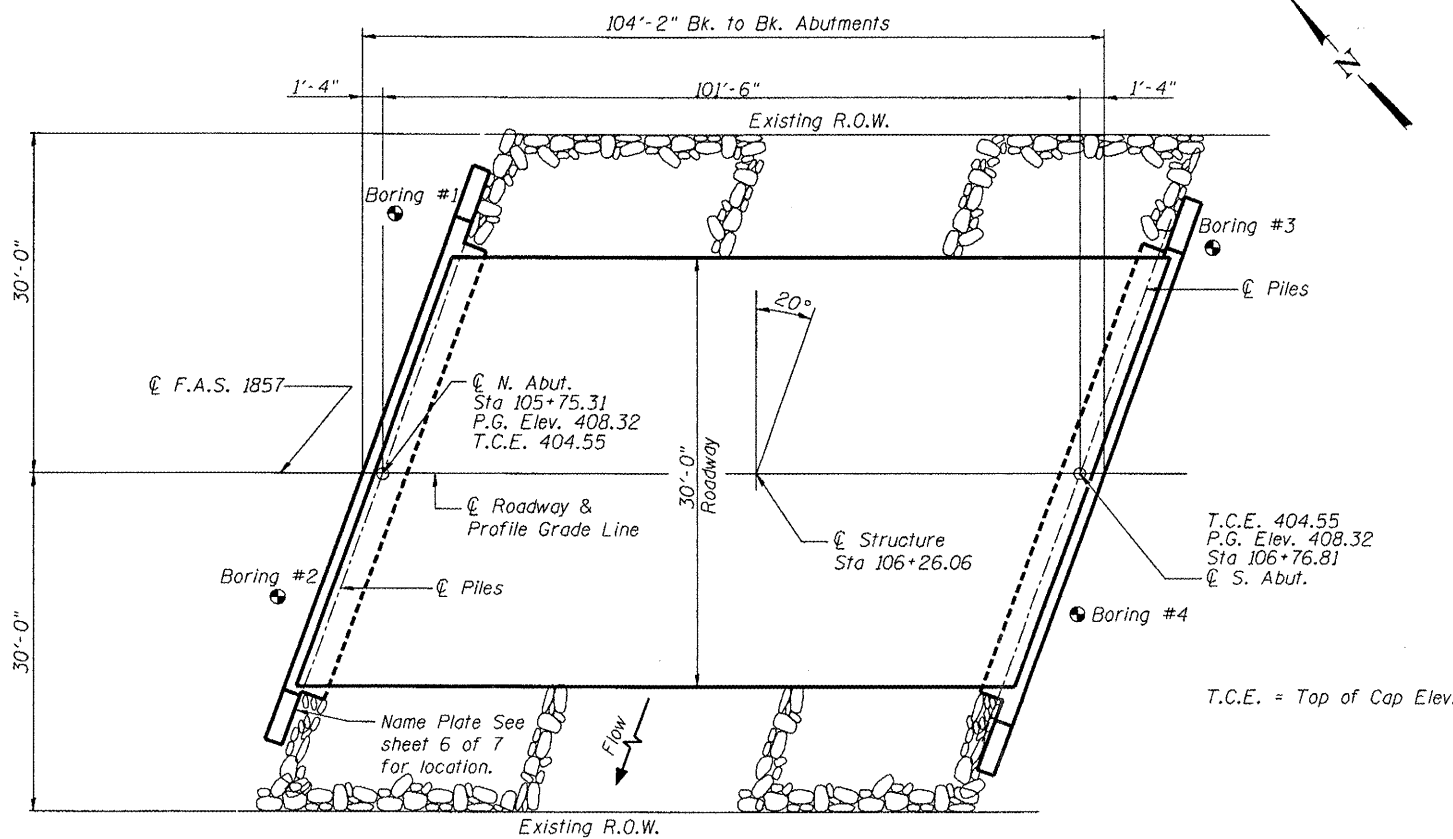

PLAN

TOTAL BILL OF MATERIAL

ITEM	UNIT	SUPER	SUB	TOTAL
Channel Excavation	Cu. Yd.			852
Stone Dumped Riprap, Class A4	Ton			461
Hot-Mix Asphalt Surface Course, Mix "C", N70	Ton	46		46
Removal of Existing Structures	L. Sum			1
Concrete Structures	Cu. Yd.		27.8	27.8
Concrete Encasement	Cu. Yd.		4.2	4.2
Steel Railing, Type SM	Foot	205		205
Reinforcement Bars	Pound		3140	3140
Furnishing Steel Piles HP 12x53	Foot		450	450
Driving Steel Piles	Foot		450	450
Test Piles Steel HP 12x53	Each		2	2
Pile Shoes	Each		12	12
Name Plates	Each		1	1
Waterproofing Membrane System	Sq. Yd.	341		341
Portland Cement Mortar Fairing Course	Foot	922		922
Precast Prestressed Concrete Deck Beams (42" Depth)	Sq. Ft.	3073		3073

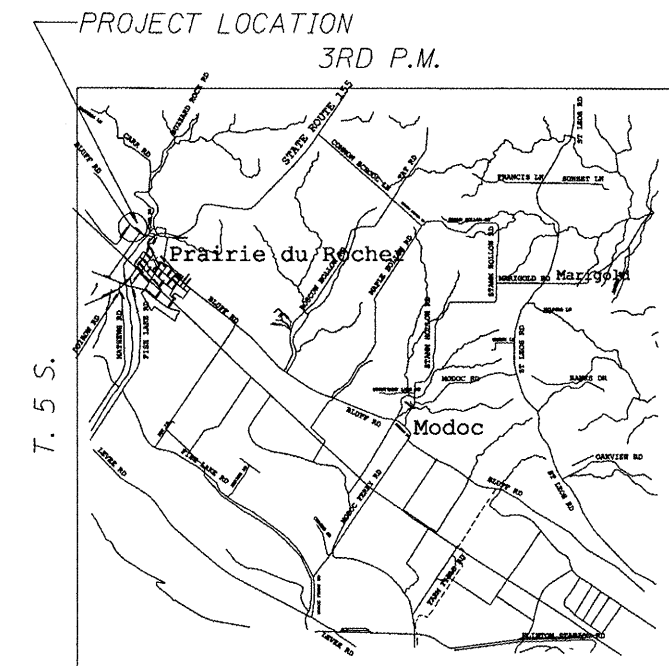

LOCATION SKETCH

I certify that to the best of my knowledge, information and belief, this bridge is structurally adequate for the design loading shown on the plans. The design is an economical one for the style of structure and complies with requirements of the current "AASHTO LRFD Bridge Design Specifications".

**GENERAL PLAN & ELEVATION
BLUFF ROAD OVER
PRAIRIE DU ROCHER CRK.
STATION 106+26.06
SN 079-3072**

SEISMIC DATA

Seismic Performance Zone (SPZ) = 2
Design Spectral Acceleration at 1.0 sec. (S_{D1}) = 0.28g
Design Spectral Acceleration at 0.2 sec. (S_{D5}) = 0.65g
Soil Site Class = D

DESIGN SPECIFICATIONS

2007 AASHTO LRFD Bridge Design Specifications with 2008 interims.

LOADING HL-93

Allow 25#/sq.ft. for future wearing surface

DESIGN STRESSES

FIELD UNITS

f'_c = 3,500 psi
 f_y = 60,000 psi (Reinforcement)

PRECAST PRESTRESSED UNITS

f'_c = 6,000 psi
 f'_{ci} = 5,000 psi
 f'_s = 270,000 psi ($1/2"$ ϕ low lax. strands)
 f'_{si} = 201,960 psi ($1/2"$ ϕ low lax. strands)

PRAIRIE DU ROCHER CREEK
BUILT 20 BY
RANDOLPH COUNTY
SECTION 99-00073-00-BR
FAS 1857 STA 106+26.06
STR. NO 079-3072 LOADING HL93

LETTERING FOR NAME PLATE

See STD. 515001

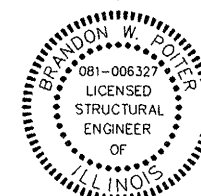

Brandon W. Potter
DATE: 11/5/08
EXP: 11/30/08

DESIGNED ASW
CHECKED BWP
DRAWN ASW
CHECKED BWP

THOUVENOT, WADE & MOERCHEN, INC.		CORPORATE OFFICE 4940 Old Collinsville Road Swansea, Illinois 62226 Tel: 618.624.4488 Fax: 618.624.6688		TWM ENGINEERS • SURVEYORS • PLANNERS	
SWANSEA • WATERLOO • EDWARDSVILLE • CARBONDALE • ST. CHARLES		F.A.S. RTE.	SECTION	COUNTY	TOTAL SHEETS
SHEET NO. 1		1857	99-00073-00-BR	RANDOLPH	11
7 SHEETS		CONTRACT NO. 97363		SHEET NO. 5	
FED. ROAD DIST. NO.		ILLINOIS		FED. AID PROJECT	

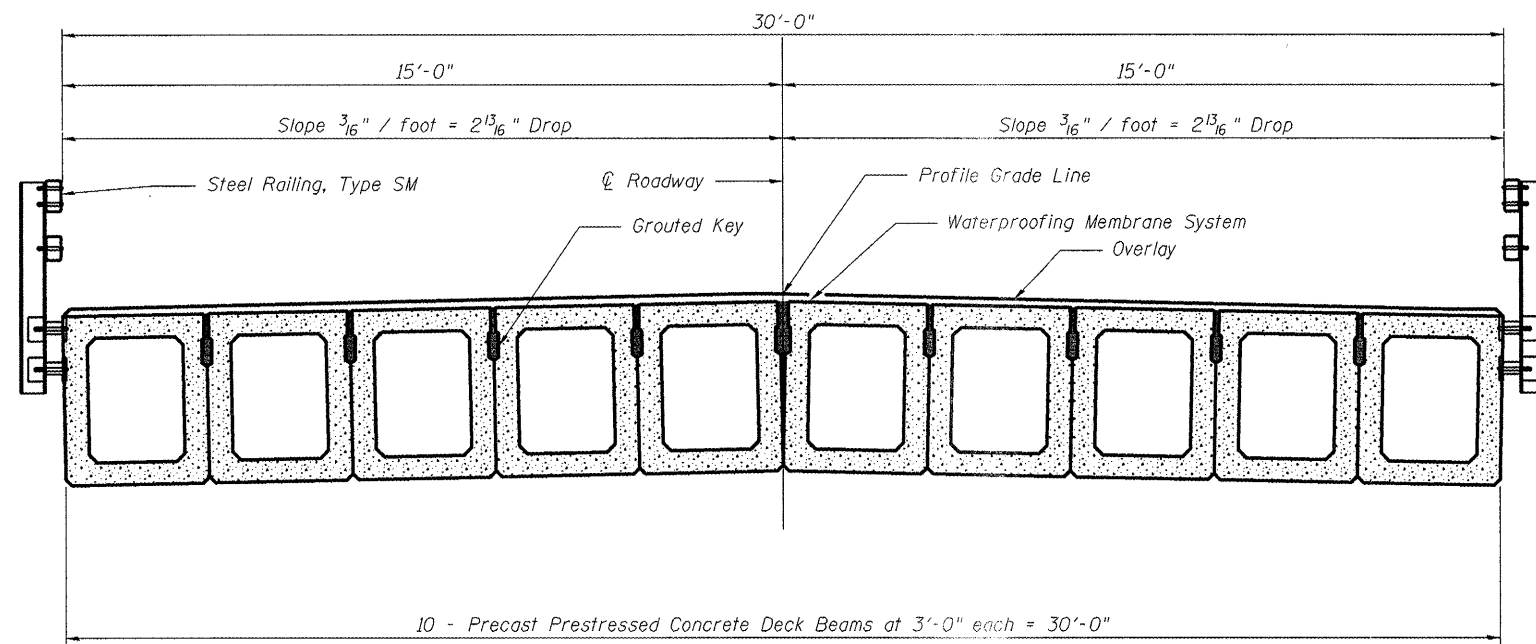

CROSS SECTION

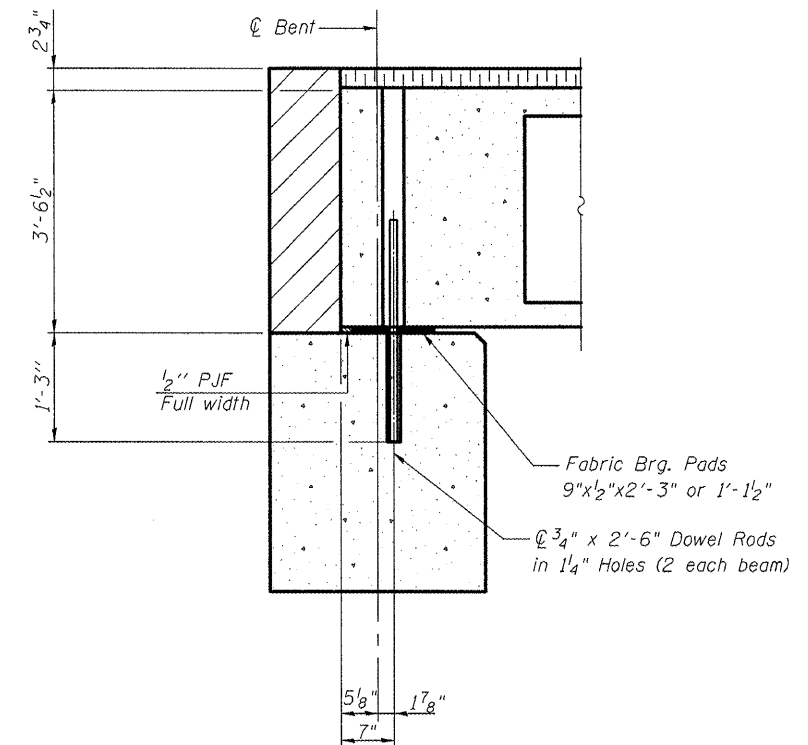

SECTION AT ABUTS.

Notes:
After beams have been erected, holes shall be drilled into substructure and anchor dowels placed. Dowel holes shall be filled with non-shrink grout to top of beam and allowed to cure min. 24 hrs. prior to grouting the shear keys.
All horizontal dimensions are at right angles to beam ends.
Hatched area to be poured after beams are in place.

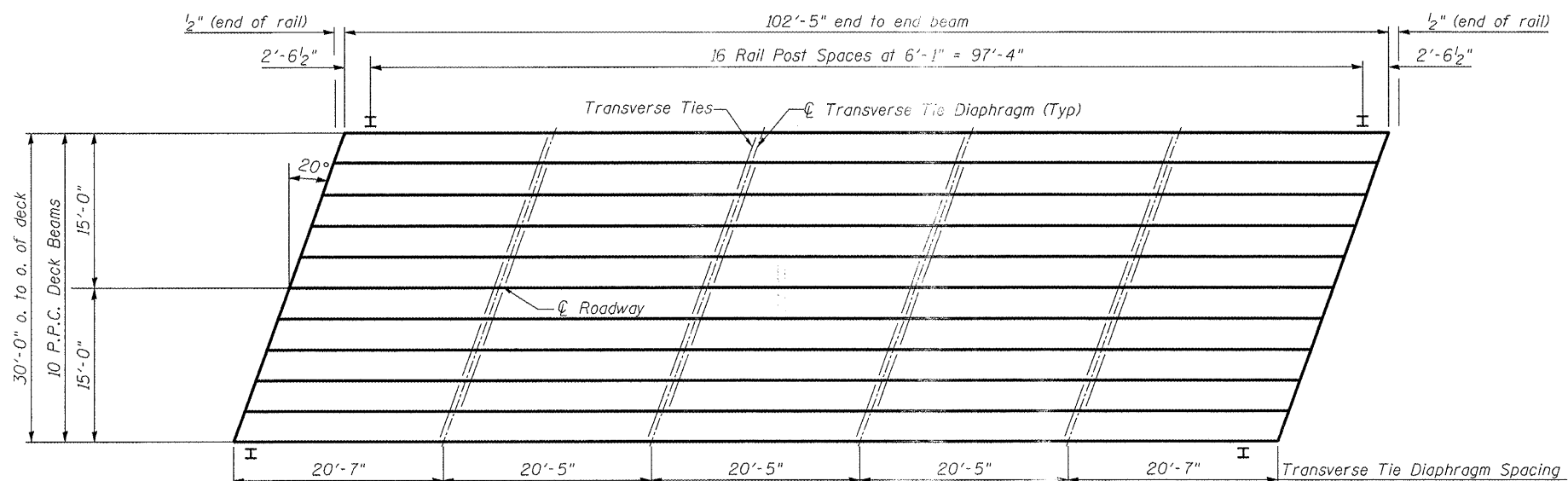

PLAN

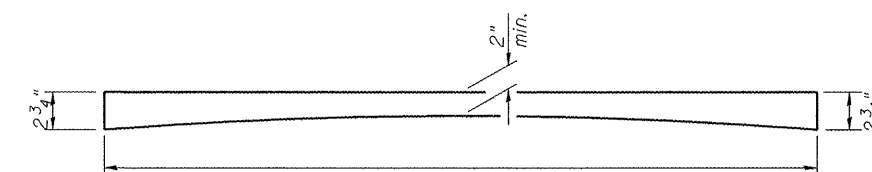

PROFILE OF OVERLAY

Thickness of Hot-Mix Asphalt and Waterproofing Membrane

PPC DECK BEAM SUPERSTRUCTURE
BLUFF ROAD OVER
PRAIRIE DU ROCHER CRK.
SN 079-3072

DESIGNED	ASW
CHECKED	BWP
DRAWN	ASW
CHECKED	BWP

SHEET NO. 2	F.A.S. RTE.	SECTION	COUNTY	TOTAL SHEETS	SHEET NO.
	1857	99-00073-00-BR	RANDOLPH	11	6
7 SHEETS					
CONTRACT NO. 97363					
FED. ROAD DIST. NO. ILLINOIS FED. AID PROJECT					

**THOUVENOT,
WADE &
MOERCHEN, INC.**
SWANSEA • WATERLOO • EDWARDSVILLE • CARBONDALE • ST. CHARLES

CORPORATE OFFICE
4940 Old Collinsville Road
Swansea, Illinois 62226
Tel: 618.624.4488
Fax: 618.624.6688



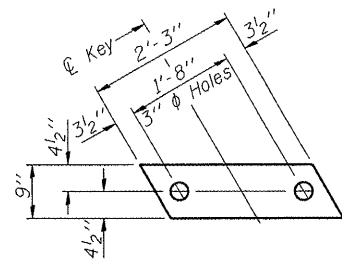

FABRIC BEARING PAD
(Interior)

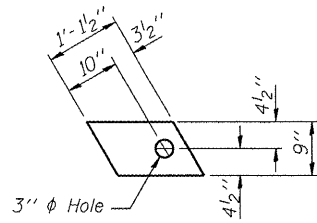

FABRIC BEARING PAD
(Exterior)

FIXED

Note: Omit holes when using expansion bearings.

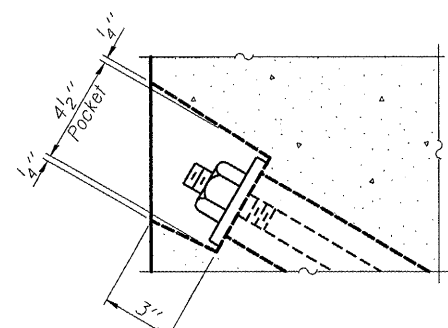

SECTION A-A

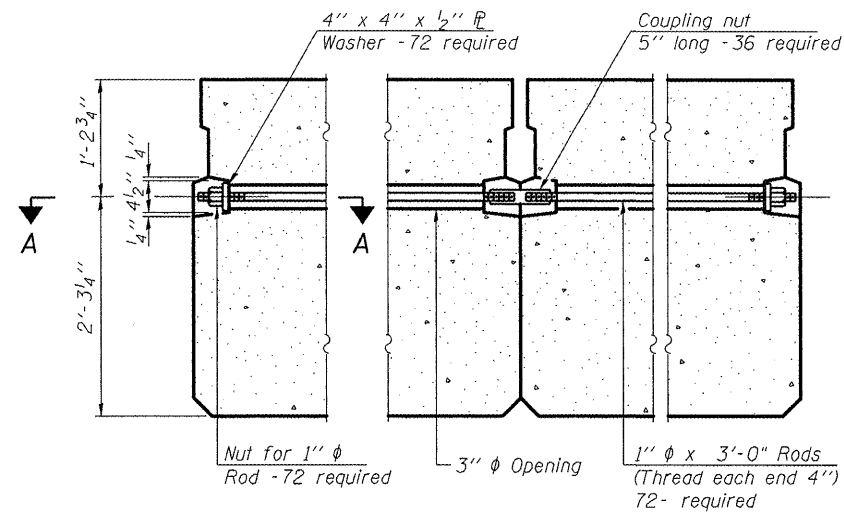

TYPICAL TRANSVERSE TIE ASSEMBLY

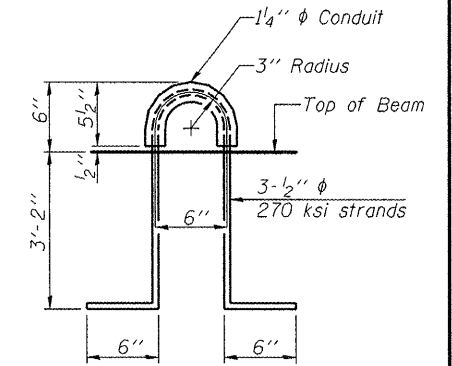

LIFTING LOOP DETAIL

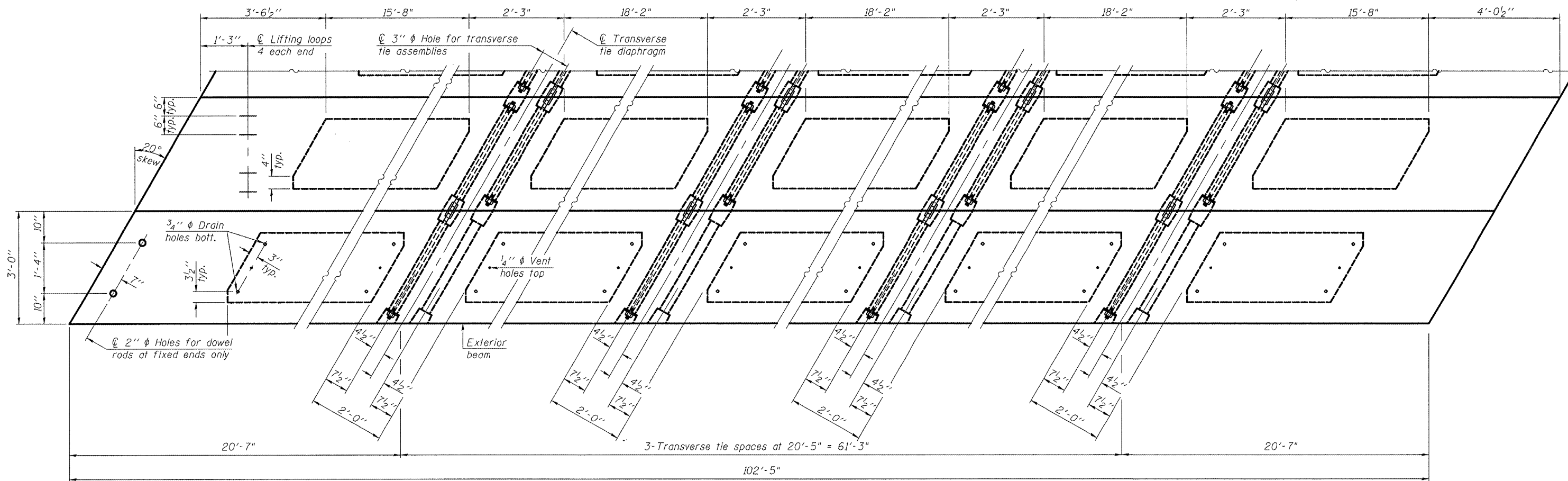

PLAN VIEW

BILL OF MATERIAL

Precast Prestressed Conc. Deck Bms. (42" depth)	Sq. Ft. 3073
---	--------------

42" x 36" DECK BEAM DETAILS
BLUFF ROAD OVER
PRAIRIE DU ROCHER CRK.
SN 079-3072

Note: Connect beams in pairs with the transverse tie configuration shown.

NOTES

- Prestressing steel shall be uncoated high strength, low relaxation 7-wire strand, Grade 270. The nominal diameter shall be 1/2" and the nominal cross-sectional area shall be 0.153 sq. in. The 1" rods in the transverse tie assembly shall be tightened to a snug fit and the threads set. Pockets on exterior faces of bridge shall be filled with grout after transverse tie assembly is in place.
- Reinforcement bars shall conform to ASTM A 706, Grade 60. (See Special Provisions)
- Two 3/8" fabric adjusting shims of the dimensions of the exterior bearing pad shall be provided for each bearing pad location.
- A minimum 2 1/2" diameter lifting pin shall be used to engage the lifting loops during handling.
- Corrosion Inhibitor, per Article 1020.05(b)(12) and 1021.06 of the Standard Specifications, shall be used in the concrete for precast prestressed concrete deck beams.
- Compressive strength of prestressed concrete, f'c, shall be 6000 psi.
- Compressive strength of prestressed concrete at release, f'ci, shall be 5000 psi.

DESIGNED	ASW
CHECKED	BWP
DRAWN	ASW
CHECKED	BWP

THOUVENOT, WADE & MOERCHEN, INC.		CORPORATE OFFICE 4940 Old Collinsville Road Swansea, Illinois 62226 Tel: 618.624.4488 Fax: 618.624.6688			
SWANSEA • WATERLOO • EDWARDSVILLE • CARBONDALE • ST. CHARLES		ENGINEERS • SURVEYORS • PLANNERS			
SHEET NO. 4	F.A.S. RTE. 1857	SECTION 99-00073-00-BR	COUNTY RANDOLPH	TOTAL SHEETS 11	SHEET NO. 8
7 SHEETS		CONTRACT NO. 97363			
FED. ROAD DIST. NO.		ILLINOIS FED. AID PROJECT			

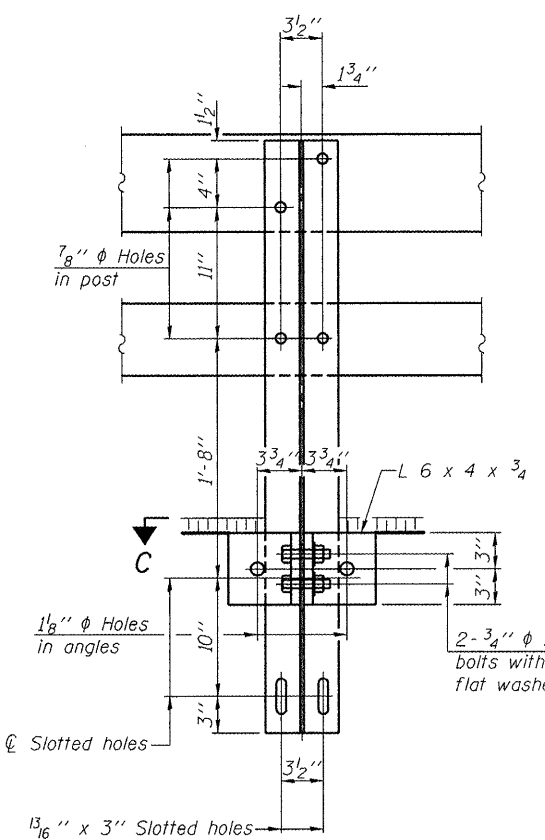
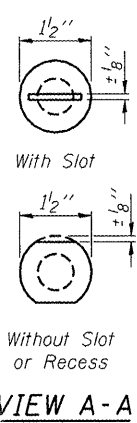
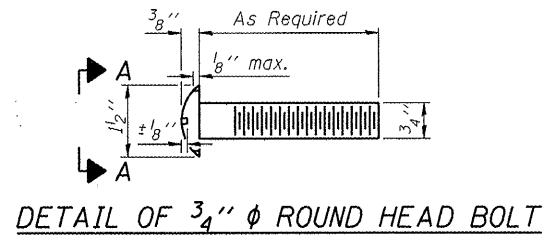

SECTION B-B

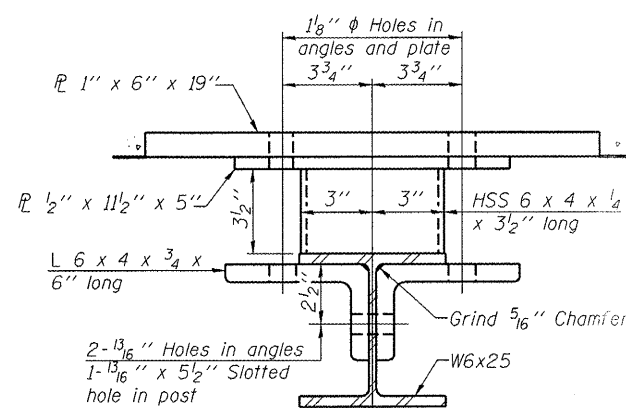

SECTION C-C

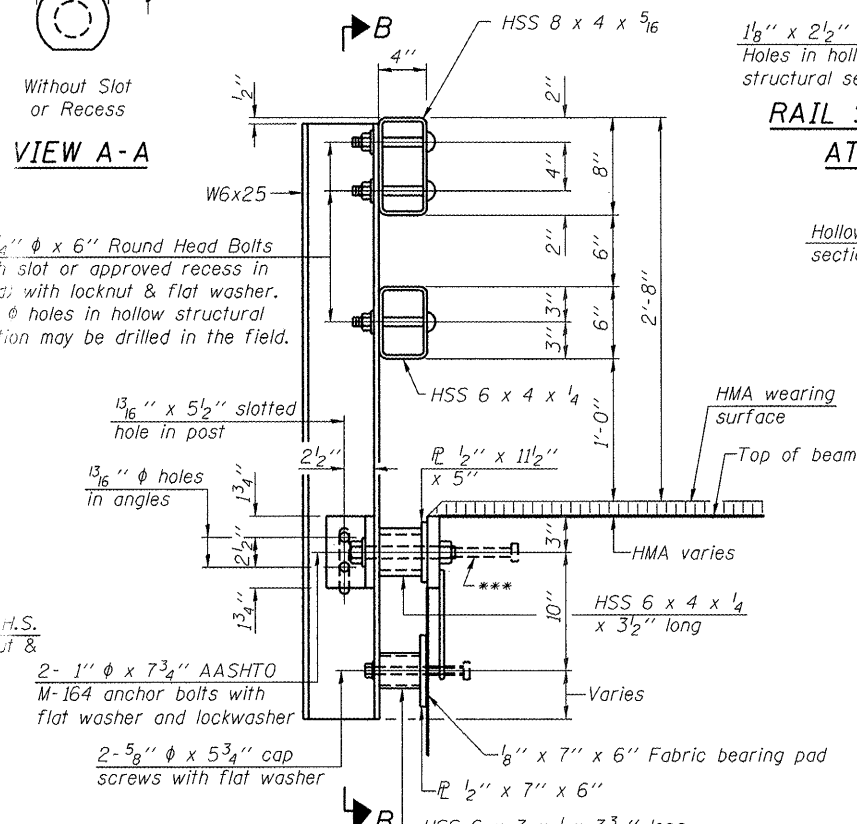

SECTION AT RAIL POST

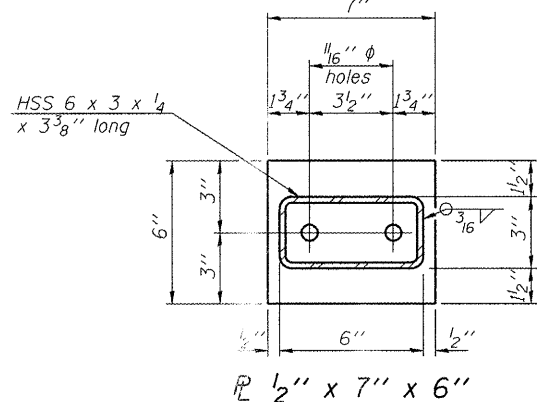
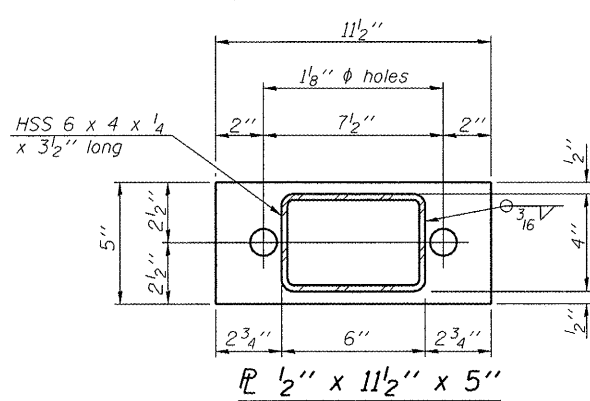

SECTION AT RAIL POST

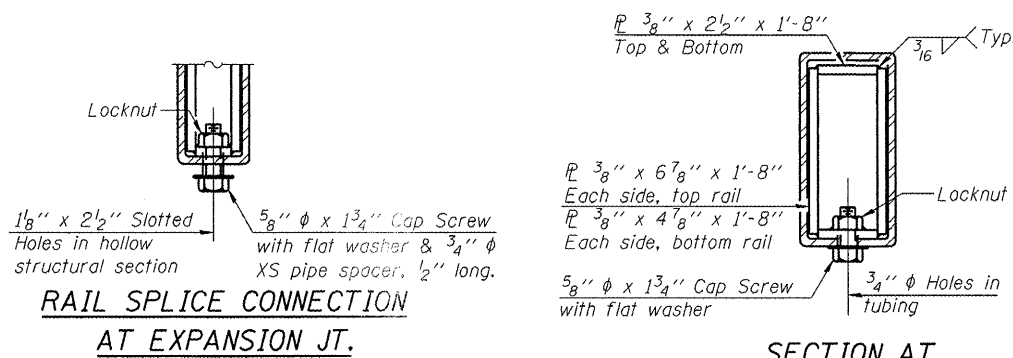

RAIL SPLICE CONNECTION AT EXPANSION JT.

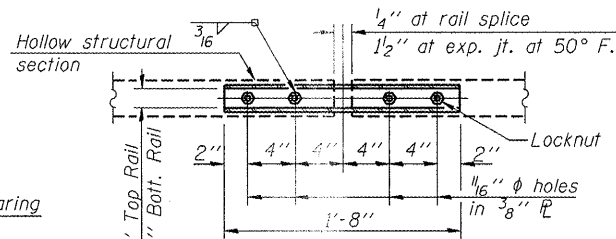

PLAN-BOTT. SPLICE P TYPICAL

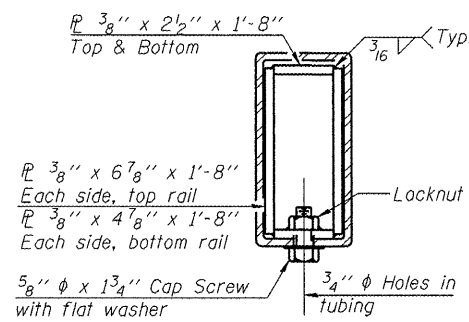

SECTION AT RAIL SPLICE

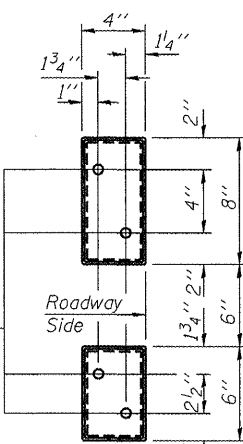

VIEW E-E

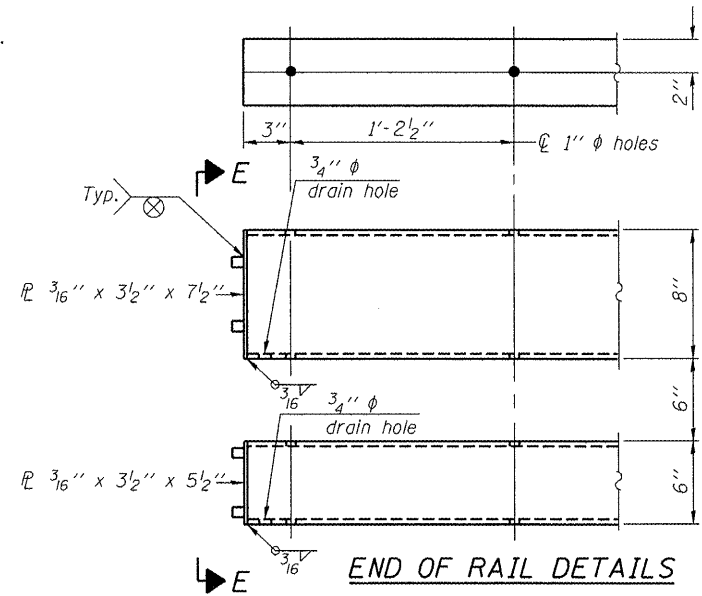

END OF RAIL DETAILS

Notes:
 All field drilled holes shall be coated with an approved zinc rich paint before erection.
 For multi-span bridges, sufficient 1/4" x 6" x 1'-2" galvanized steel shims shall be provided to align rail between adjacent spans. Cost included with Steel Railing, Type SM.
 All steel rail members shall be galvanized according to Article 509.05 of the Standard Specifications.
 ***The studs of the anchor devices shall be placed below the top reinforcement bars and the outermost longitudinal reinforcement bar shall be placed directly above the studs of the rail post anchor device.

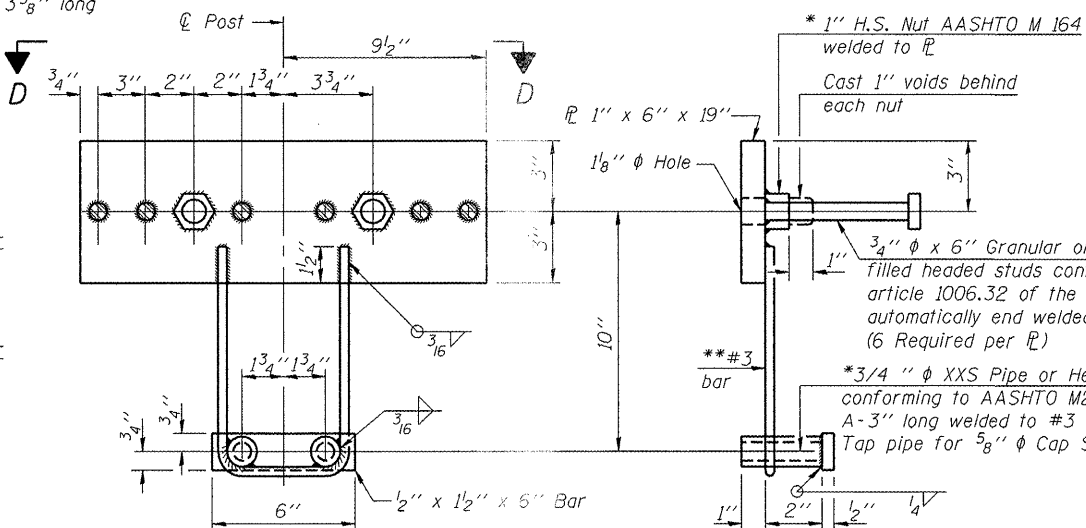

ANCHOR DEVICE

*Threaded areas shall be plugged or blocked off during casting of beam. Galvanized after fabrication.

*Whenever the lower insert assemblies interfere with strand locations, the #3 bars shall be cut and adjusted in order to allow raising or lowering of the lower inserts. Maximum adjustment not to exceed 1/2".

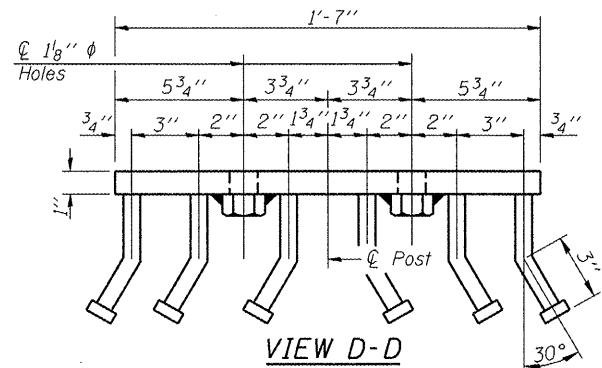

VIEW D-D

BILL OF MATERIAL

Item	Unit	Quantity
Steel Railing, Type SM	Foot	205

STEEL RAILING, TYPE SM
 BLUFF ROAD OVER
 PRAIRIE DU ROCHER CRK.
 SN 079-3072

DESIGNED ASW
CHECKED BWP
DRAWN ASW
CHECKED BWP

R-34HMAWS 05-16-08

(16'-3" Maximum Post Spacing) (1/4" minimum to 3/8" maximum HMA thickness)

THOUVENOT,
 WADE &
 MOERCHEN, INC.
 SWANSEA • WATERLOO • EDWARDSVILLE • CARBONDALE • ST. CHARLES

CORPORATE OFFICE
 4940 Old Collinsville Road
 Swansea, Illinois 62226
 Tel: 618.624.4488
 Fax: 618.624.6688



SHEET NO. 5	F.A.S. RTE.	SECTION	COUNTY	TOTAL SHEETS	SHEET NO.
	1857	99-00073-00-BR	RANDOLPH	11	9
7 SHEETS	CONTRACT NO. 97363		FED. ROAD DIST. NO. ILLINOIS FED. AID PROJECT		

STATE OF ILLINOIS
DEPARTMENT OF TRANSPORTATION

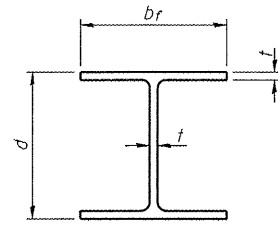

STEEL PILE TABLE

Designation	Depth d	Flange width br	Web and Flange thickness t	Encasement diameter A
HP 14x117	14 1/4"	14 7/8"	1 3/16"	30"
x102	14"	14 3/4"	1 1/16"	30"
x89	13 7/8"	14 3/4"	5/8"	30"
x73	13 5/8"	14 5/8"	1/2"	30"
HP 12x84	12 1/4"	12 1/4"	1 1/16"	24"
x74	12 1/8"	12 1/4"	5/8"	24"
x63	12"	12 1/8"	1/2"	24"
x53	11 3/4"	12"	7/16"	24"
HP 10x57	10"	10 1/4"	9/16"	24"
x42	9 3/4"	10 1/8"	7/16"	24"
HP 8x36	8"	8 1/8"	7/16"	18"

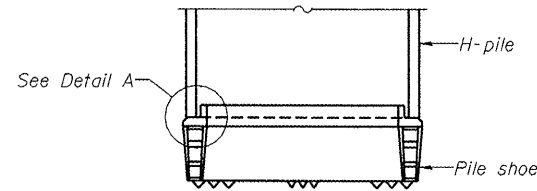

ELEVATION

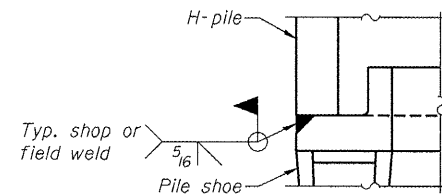

DETAIL A

H-PILE SHOE ATTACHMENT

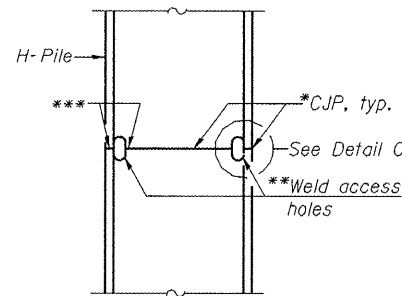

ELEVATION

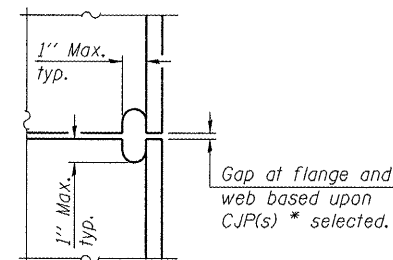

DETAIL C

COMPLETE PENETRATION WELD SPLICE

WELDED PLATE FIELD SPLICE

Note:
The steel H-piles shall be according to AASHTO M270 Grade 50.

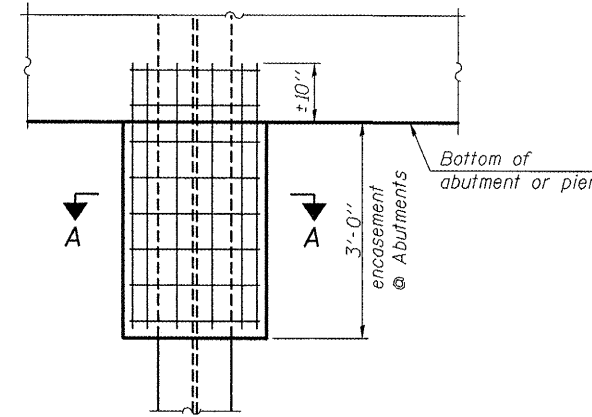

ELEVATION

PILE ENCASEMENT

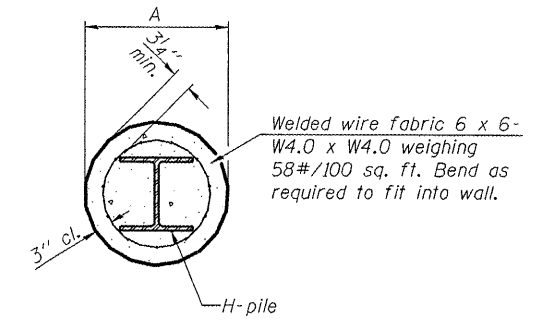

Note:
Forms for encasement may be omitted when soil conditions permit.

SECTION A-A

Designation	F	F _t	F _w	W	W _t	W _w
HP 14x117	12 1/2"	1"	7/8"	7 3/4"	5/8"	1/2"
x102	12 1/2"	7/8"	3/4"	7 3/4"	5/8"	1/2"
x89	12 1/2"	3/4"	1 1/16"	7 3/4"	5/8"	1/2"
x73	12 1/2"	5/8"	9/16"	7 3/4"	5/8"	1/2"
HP 12x84	10"	7/8"	1 1/16"	6 1/2"	5/8"	1/2"
x74	10"	7/8"	1 1/16"	6 1/2"	5/8"	1/2"
x63	10"	5/8"	1/2"	6 1/2"	1/2"	3/8"
x53	10"	5/8"	1/2"	6 1/2"	1/2"	3/8"
HP 10x57	8"	3/4"	9/16"	5 1/4"	1/2"	3/8"
x42	8"	5/8"	9/16"	5 1/4"	1/2"	3/8"
HP 8x36	7"	5/8"	7/16"	4 1/4"	1/2"	3/8"

STEEL PILES
BLUFF ROAD OVER
PRAIRIE DU ROCHER CRK.
SN 079-3072

DESIGNED ASW
CHECKED BWP
DRAWN ASW
CHECKED BWP
F-HP

9-3-07

*Use joint conforming to Figure 3.4 in AWS D1.1, Structure Welding Code - Steel.

**Preparation per Fig. 5.2 in AWS D1.1, Structure Welding Code - Steel.

***Interrupt welds 1/4" from end of each pile.

THOUVENOT,
WADE &
MOERCHEN, INC.

CORPORATE OFFICE
4940 Old Collinsville Road
Swansea, Illinois 62226
Tel: 618.624.4488
Fax: 618.624.6688

SWANSEA • WATERLOO • EDWARDSVILLE • CARBONDALE • ST. CHARLES



SHEET NO. 7	F.A.S. RTE.	SECTION	COUNTY	TOTAL SHEETS	SHEET NO.
	1857	99-00073-00-BR	RANDOLPH	11	11
7 SHEETS			CONTRACT NO. 97363		
FED. ROAD DIST. NO. _		ILLINOIS FED. AID PROJECT			