

UNIT DUCT SHALL BE TERMINATED AT THE L-823 CONNECTORS AND SEALED WITH HEAT SHRINK AS SPECIFIED.

STAKE MOUNTED MEDIUM INTENSITY MARKER LIGHTS

N.T.S.

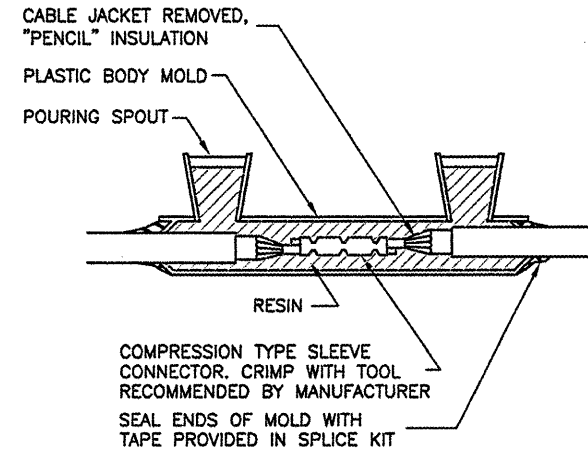

FOR EMERGENCY IN-LINE CONNECTIONS OF EXISTING CABLES CUT DURING CONSTRUCTION.

TYPE A

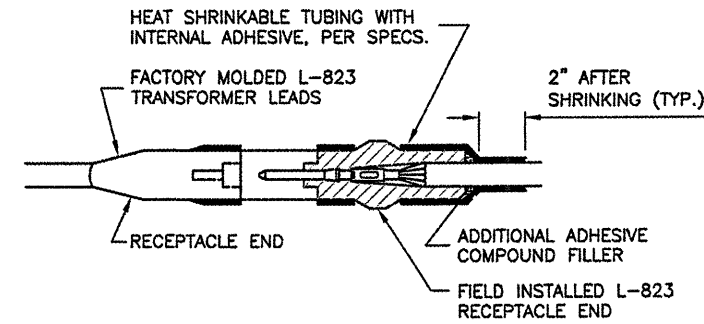

FOR SPLICES AT TAXIWAY LIGHTS AND SIGNS.

TYPE C

CABLE SPLICE NOTES

1. INSIDE DIAMETER OF CONNECTOR SHALL PROPERLY MATCH THE OUTSIDE DIAMETER OF CABLE.
2. THE COST OF FURNISHING AND INSTALLING ALL SPLICE MATERIALS SHALL BE INCIDENTAL TO THE ASSOCIATED CABLE ITEMS.
3. THE CONTRACTOR SHALL HAVE A MINIMUM OF TWO (2) TYPE A SPLICE KITS ON THE JOB SITE AT ALL TIMES FOR EMERGENCY REPAIRS.
4. ALL SPLICES WILL BE MADE AT LIGHTS. ANY AIRFIELD LIGHTING CABLE CUT BY THE CONTRACTOR WILL BE REPLACED FROM LIGHT TO LIGHT AT THE CONTRACTOR'S EXPENSE.

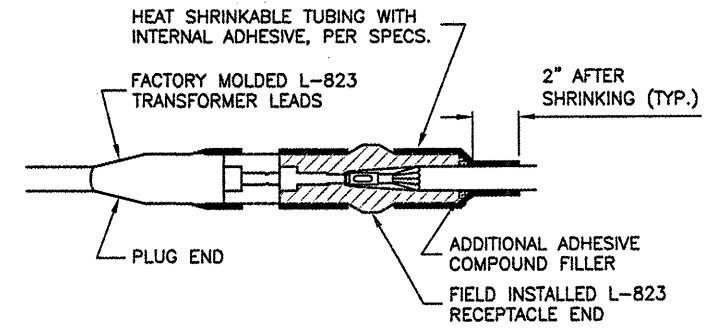

FOR SPLICES AT TAXIWAY LIGHTS AND SIGNS.

TYPE D

CABLE SPLICES

N.T.S.

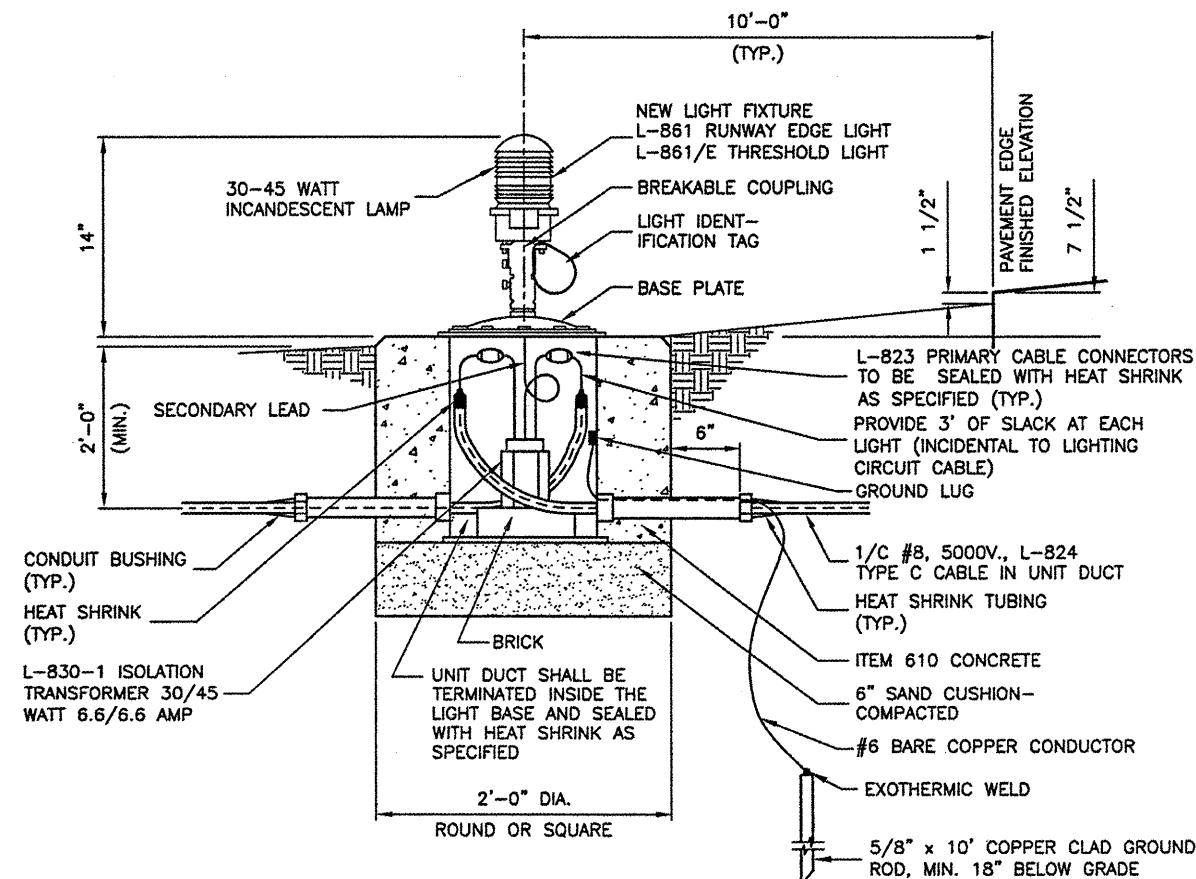

BASE MOUNTED MEDIUM INTENSITY MARKER LIGHTS

N.T.S.

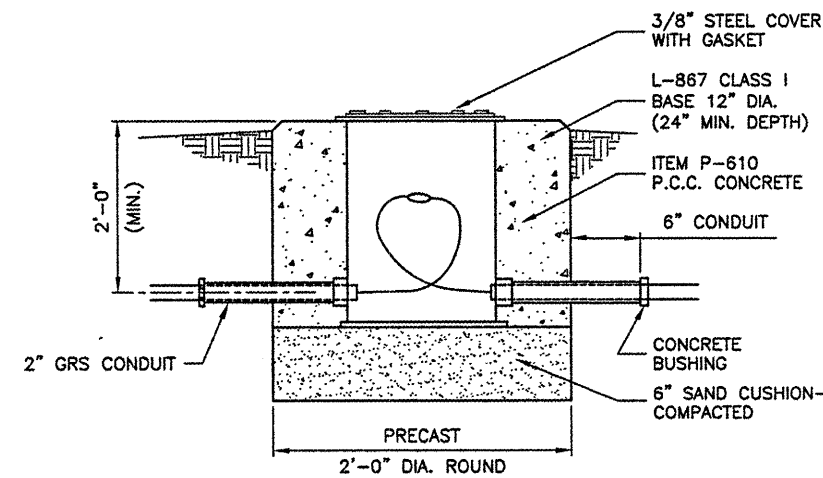

SPLICE CAN DETAIL

N.T.S.

REVISIONS		
NUMBER	BY	DATE

0 1 2
THIS BAR IS EQUAL TO 2' AT FULL SCALE (34x22).

SPARTA COMMUNITY AIRPORT
HUNTER FIELD
SPARTA, ILLINOIS

WIDEN AND OVERLAY RUNWAY 18/36

ELECTRICAL & LIGHTING DETAILS

© Copyright CMT, Inc.

CMT
CRAWFORD, MARRIY & TILLY, INC.
CONSULTING ENGINEERS
License No. 184-000613

DESIGN BY:	KLB
DRAWN BY:	CMT
CHECKED BY:	JEF
APPROVED BY:	JEF
DATE:	12/31/2008
JOB No:	0641203
IL PROJ. NO. SAR-3652	
AIP PROJ. NO. 3-17-0094-B9	
SHEET 10 OF 28 SHEETS	