

K:\Damilley\0504203 Taxiway Extension\Draw\Sheets
 FILE: 18_ELECDET4.dwg
 LAYOUT: ELECDET4
 UPDATE BY: dallan
 SURVEY BOOK #
 DATE: Mon 1/5/09 5:51pm
 XREF DWG: Clintinfo.dwg

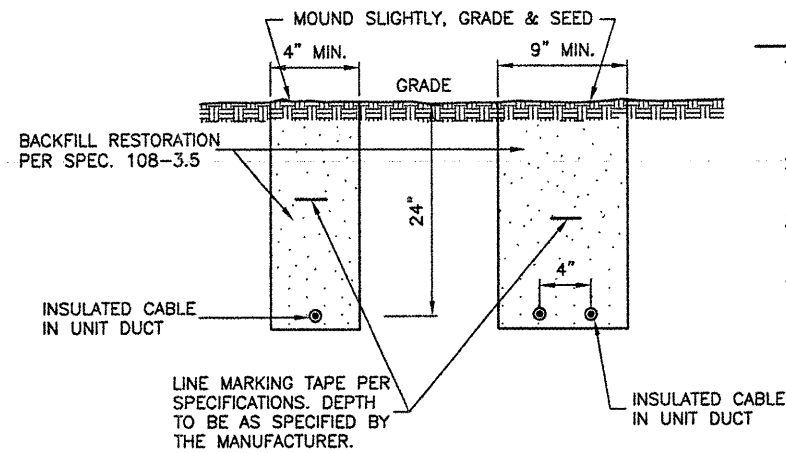

TRENCH DETAIL
N.T.S.

- NOTES**
- TRENCHES WITH MORE THAN 2 CABLES SHALL BE INCREASED 3" IN WIDTH FOR EACH ADDITIONAL CABLE. IF SPECIFIED ON PLANS, TWO PARALLEL TRENCHES MAY BE CONSTRUCTED.
 - DEPTH OF TRENCHES SHALL BE AS SHOWN ABOVE UNLESS OTHERWISE SPECIFIED ON THE PLANS.
 - SAND BACKFILL SHALL BE USED IF THE EXISTING SOIL DOES NOT MEET THE BACKFILL REQUIREMENTS.
 - ALL DISTURBED SURFACES SHALL BE RESTORED TO THEIR ORIGINAL CONDITION. COST IS INCIDENTAL TO ITEM 108.

NOTE: AT CONTRACTOR'S OPTION, CABLE PLOWING MAY BE USED IN LIEU OF TRENCHING

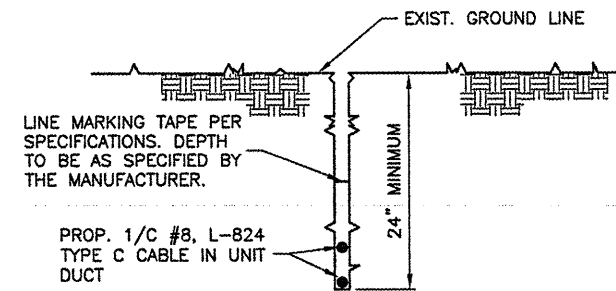

NOTE: WHERE TWO UNIT DUCTS ARE TO BE INSTALLED, CONTRACTOR MAY PLOW UNIT DUCTS SEPERATELY (SIDE BY SIDE)

CABLE IN UNIT-DUCT - PLOWED
N.T.S.

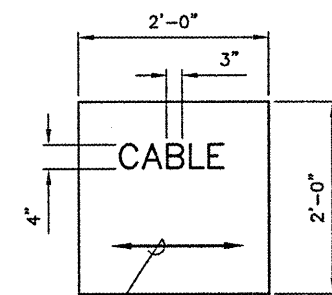

ARROW TO INDICATE THE DIRECTION OF THE CABLE RUN

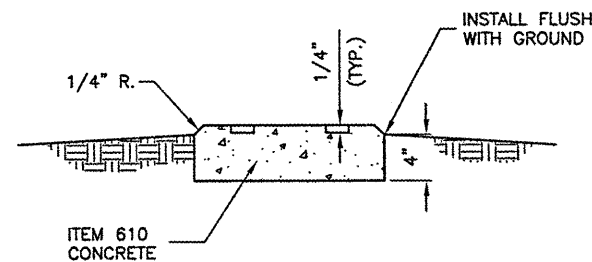

TURF CABLE / SPLICE MARKER
N.T.S.

- NOTES**
- CABLE MARKERS SHALL BE INSTALLED AT ALL BENDS AND EVERY 200' ALONG THE HOMERUN.
 - ITEM 610 CONCRETE SHALL BE USED.
 - ALL EXPOSED EDGES SHALL BE EDGED WITH A 1/4" RADIUS TOOL.
 - THE COST OF FURNISHING AND INSTALLING NEW MARKERS SHALL BE INCIDENTAL TO THE ASSOCIATED ITEMS.
 - 0.049 CU. YD. CONCRETE PER MARKER.
 - A MARKER CONFORMING TO THIS DETAIL MARKED "SPLICE" SHALL BE INSTALLED AT ALL SPLICE LOCATIONS NOT IN LIGHT CANS OR MANHOLES.

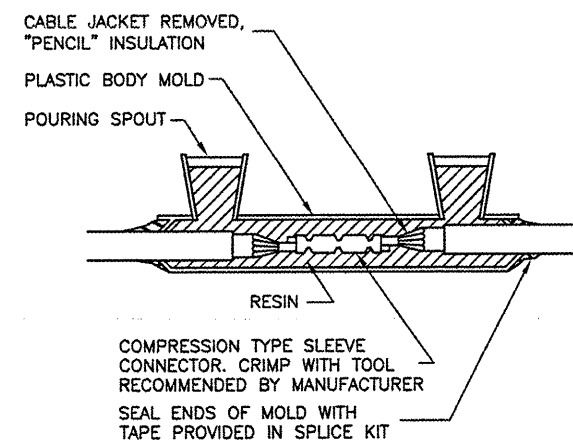

FOR IN-LINE CONNECTIONS OF EXISTING CABLES CUT DURING CONSTRUCTIONS.

TYPE A

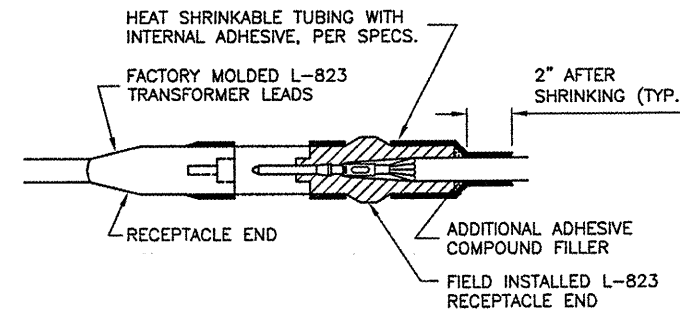

FOR SPLICES AT TAXIWAY LIGHTS AND SIGNS.

TYPE C

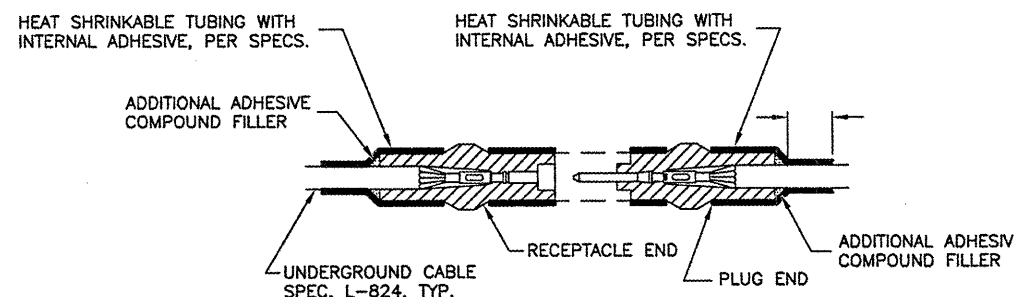

NOT TO BE USED IN THIS PROJECT UNLESS OTHERWISE DIRECTED BY ENGINEER

TYPE B

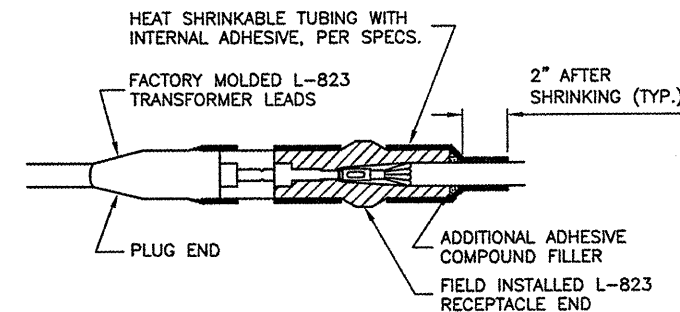

FOR SPLICES AT TAXIWAY LIGHTS AND SIGNS.

TYPE D

CABLE SPLICES
N.T.S.

- NOTES**
- INSIDE DIAMETER OF CONNECTOR SHALL PROPERLY MATCH THE OUTSIDE DIAMETER OF CABLE.
 - THE COST OF FURNISHING AND INSTALLING ALL SPLICE MATERIALS SHALL BE INCIDENTAL TO THE ASSOCIATED CABLE ITEMS.
 - THE CONTRACTOR SHALL HAVE A MINIMUM OF TWO (2) TYPE A SPLICE KITS ON THE JOB SITE AT ALL TIMES FOR EMERGENCY REPAIRS.

REVISIONS

NUMBER	BY	DATE

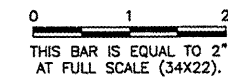

VERMILLION COUNTY AIRPORT
 DANVILLE, ILLINOIS
 EXTEND PARALLEL TAXIWAY 600 FEET
 ELECTRICAL DETAILS SHEET 4

© Copyright, CMT, Inc.
CMT
 CRAWFORD MURPHY & TILLY, INC.
 CONSULTING ENGINEERS
 License No. 984-000813



DESIGN BY:	JEF
DRAWN BY:	DPA
CHECKED BY:	JEF
APPROVED BY:	JEF
DATE:	01/09/2009
JOB No:	05042-0300
ILLINOIS PROJECT DNV-3537	
A.I.P. PROJECT 3-17-0032-B10	
SHEET 18 OF 26 SHEETS	