

SEE SHEET NO. 2 FOR  
INDEX OF SHEETS AND  
LIST OF ILLINOIS DOT STANDARDS

**STATE OF ILLINOIS**  
**DEPARTMENT OF TRANSPORTATION**  
**DIVISION OF HIGHWAYS**  
**PROPOSED**  
**HIGHWAY PLANS**  
**FAP ROUTE 323 (US 36)**  
**SECTION (142BY) BR**  
**PROJECT ACNHPP-0323 (033)**  
**C-97-076-06**  
**MOULTRIE COUNTY**  
**STRUCTURE REPLACEMENT**  
**OVER DRAINAGE DITCH NO. 4**

F.A.P. RTE.	SECTION	COUNTY	TOTAL SHEETS	SHEET NO.
323	(142BY) BR	MOULTRIE	35	1
FED. ROAD DIST. NO.		ILLINOIS	CONTRACT NO. 74165	
D-97-038-06				



FUNCTIONAL CLASSIFICATION: OTHER PRINCIPLE ARTERIAL  
DESIGN SPEED: 60 MPH  
POSTED SPEED: 55 MPH  
ADT 2,450 (2013)  
PV 86.5%  
SU 3.3%  
MU 10.2%

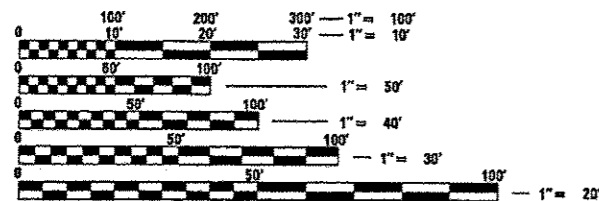

FULL SIZE PLANS HAVE BEEN PREPARED USING STANDARD ENGINEERING SCALES. REDUCED SIZED PLANS WILL NOT CONFORM TO STANDARD SCALES. IN MAKING MEASUREMENTS ON REDUCED PLANS, THE ABOVE SCALES MAY BE USED.

J.U.L.I.E.  
JOINT UTILITY LOCATION INFORMATION FOR EXCAVATION  
1-800-892-0123  
OR 811

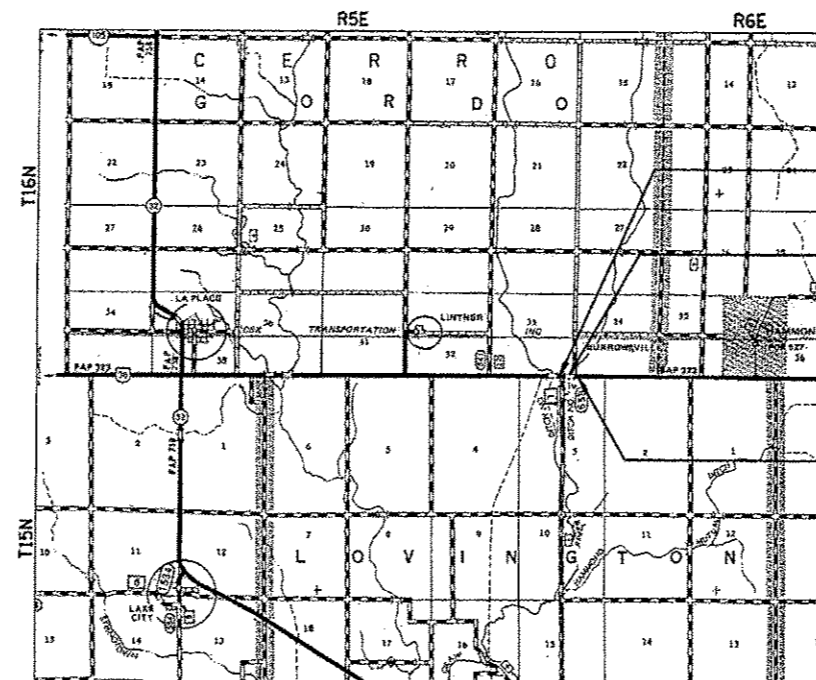

BEGIN SECTION (142BY) BR  
STA 314+28.25

PROPOSED SN 070-2018  
STA 316+71  
DOUBLE 12 X 10 R.C. BOX CULVERT  
54' 0-0  
SKEW 0°

END SECTION (142BY) BR  
STA 318+97.50

NET LENGTH OF SECTION: 469.25 FEET = 0.089 MILES

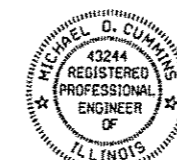
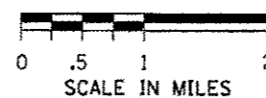

*Michael D. Cummins* 8/6/14

ILLINOIS PROFESSIONAL NO. 43244  
(Expires 11/30/15)

DISTRICT 7 NO. (217) 342-3951  
PROJECT ENGINEER - MARK DAUGHERTY  
UNIT CHIEF

CONTRACT NO. 74165



STATE OF ILLINOIS  
DEPARTMENT OF TRANSPORTATION  
DIVISION OF HIGHWAYS

SUBMITTED August 13 2014  
Roger L. Drishell for  
DEPUTY DIRECTOR OF HIGHWAYS, REGION ENGINEER

Oct 17 2014  
John D. Baranzelli, P.E.  
ENGINEER OF DESIGN AND ENVIRONMENT

Oct 17 2014  
Omer Osman, P.E.  
DIRECTOR OF HIGHWAYS, CHIEF ENGINEER

**PRINTED BY THE AUTHORITY  
OF THE STATE OF ILLINOIS**

**INDEX OF SHEETS**

1 COVER SHEET  
 2 INDEX OF SHEETS, GENERAL NOTES AND HIGHWAY STANDARDS  
 3-7 SUMMARY OF QUANTITIES  
 8-10 TYPICAL CROSS SECTIONS  
 11-12 SCHEDULE OF QUANTITIES  
 13 ALIGNMENT & CROSS TIES  
 14 STAGE 1 TRAFFIC CONTROL AND PROTECTION  
 15 STAGE 2 TRAFFIC CONTROL AND PROTECTION  
 16-17 STAGE CONSTRUCTION DETAILS  
 18 PLAN & PROFILE  
 19 REMOVAL PLANS  
 20 GUARDRAIL LAYOUT & SHOULDER WIDENING DETAILS  
 21 DRAINAGE AND EROSION CONTROL  
 22 CULVERT BACKFILL  
 23 ENTRANCE & SIDE ROAD DETAILS  
 24-30 STRUCTURE PLANS SN 070-2018  
 31-35 CROSS SECTIONS

**LIST OF ILLINOIS DOT HIGHWAY STANDARDS**

STANDARD NO.	DESCRIPTION
000001-06	STANDARD SYMBOLS ABBREVIATIONS AND PATTERNS
001001-02	AREAS OF REINFORCEMENT BARS
001006	DECIMAL OF AN INCH AND OF A FOOT
280001-07	TEMPORARY EROSION CONTROL SYSTEMS
515001-03	NAME PLATE FOR BRIDGE
542306-02	PRECAST REINFORCED CONCRETE ELLIPTICAL FLARED END SECTION
630001-10	STEEL PLATE BEAM GUARD RAIL
630101-09	GUARDRAIL MOUNTED ON EXISTING CULVERTS
630201-06	PCC/HMA STABILIZATION AT STEEL PLATE BEAM GUARDRAIL
630301-06	SHOULDER WIDENING FOR TYPE 1 (SPECIAL) GUARD RAIL TERMINALS
635006-03	REFLECTOR AND TERMINAL MARKER PLACEMENT
635011-02	REFLECTOR MARKER AND MOUNTING DETAIL
666001-01	RIGHT OF WAY MARKERS
701006-05	OFF ROAD OPERATIONS 2L 2W, 15FT TO 24" FROM PAVEMENT EDGE
701011-04	OFF ROAD MOVING OPERATIONS 2L 2W, DAY ONLY.
701201-04	LANE CLOSURE 2L 2W, DAY ONLY
701301-04	LANE CLOSURE 2L 2W, SHORT TIME OPERATIONS
701311-03	LANE CLOSURE 2L 2W, MOVING OPERATIONS DAY ONLY
701321-14	LANE CLOSURE 2L 2W, BRIDGE REPAIR BARRIER
701326-04	LANE CLOSURE 2L 2W, PAVEMENT WIDENING
701901-04	TRAFFIC CONTROL DEVICES
704001-07	TEMPORARY CONCRETE BARRIER
780001-05	TYPICAL PAVEMENT MARKINGS

**GENERAL NOTES**

- ALL SAWCUTTING OF EXISTING PAVEMENT SHALL BE CONSIDERED INCLUDED IN THE PAY ITEMS INVOLVED. THE MINIMUM SAW DEPTH IN THE PAVEMENT SHALL BE 1/2" UNLESS OTHERWISE NOTED.
- THE THICKNESS OF HMA MIXTURES SHOWN ON THE PLANS IS THE NOMINAL THICKNESS. DEVIATIONS FROM THE NOMINAL THICKNESS WILL BE PERMITTED WHEN SUCH DEVIATIONS OCCUR DUE TO IRREGULARITIES IN THE EXISTING SURFACE OR BASE ON WHICH THE HMA MIXTURE IS PLACED.
- ANY REFERENCE TO A STANDARD IN THESE PLANS SHALL BE INTERPRETED TO MEAN THE EDITIONS AS INDICATED BY THE SUBNUMBER LISTED ON THE INDEX OF SHEETS OR THE COPY OF THE STANDARD INCLUDED IN THESE PLANS.
- FACTORS USED FOR ESTIMATING PLAN QUANTITIES ARE AS FOLLOWS AND SHALL NOT BE USED FOR THE BASIS OF FINAL QUANTITIES:  
 HOT-MIX ASPHALT: 112 LBS/SQ YD/1" THICKNESS  
 AGGREGATE 2.05 TONS/CU YD  
 BITUMINOUS MATERIALS:  
 FOG COAT BETWEEN LIFTS 0.025 LB/SQ FT  
 ON MILLED HMA 0.05 LB/SQ FT
- ABANDONED UNDERGROUND UTILITIES THAT CONFLICT WITH CONSTRUCTION SHALL BE DISPOSED OF OUTSIDE THE LIMITS OF THE RIGHT OF WAY ACCORDING TO ARTICLE 202.03 OF THE STANDARD SPECIFICATIONS AND AS DIRECTED BY THE ENGINEER. THIS WORK WILL NOT BE PAID FOR SEPARATELY BUT SHALL BE INCLUDED IN THE COST OF EARTH EXCAVATION.
- ALL DISTURBED AREAS WITHIN THE CONSTRUCTION LIMITS SHALL BE FERTILIZED AND SEEDED. SEEDING SHALL BE CLASS 2 (SPECIAL) ACCORDING TO THE APPLICABLE ARTICLES OF SECTION 250 OF THE STANDARD SPECIFICATIONS. SEEDING SHALL NOT BE PERMITTED AT ANY TIME WHEN THE GROUND IS FROZEN, WET, OR IN AN UNTILLABLE CONDITION. LOCATIONS TO BE SEEDED WILL BE DETERMINED BY THE ENGINEER.
- THE CONTRACTOR SHALL BE RESPONSIBLE FOR PROTECTING UTILITY PROPERTY FROM CONSTRUCTION OPERATIONS AS OUTLINED IN ARTICLE 107.31 OF THE STANDARD SPECIFICATIONS. THE JULIE NUMBER IS 800-892-0123. A MINIMUM OF 48 HOURS ADVANCE NOTICE IS REQUIRED.
- EXISTING TRAFFIC BARRIER TERMINALS TO BE REMOVED SHALL BE PAID FOR AS GUARDRAIL REMOVAL.
- ALL ELEVATIONS REFER TO U.S.G.S MEAN SEA LEVEL DATUM.
- FOR STABILIZATION, ALL TYPE III BARRICADES SHALL REQUIRE A MINIMUM OF FOUR SANDBAGS PER BARRICADE.
- THE QUANTITY OF SHORT TERM PAVEMENT MARKING SHOWN IN THE PLANS IS BASED ON ONE APPLICATION EACH FOR THE INITIAL OPENING OF THE COMPLETED STRUCTURE TO TWO LANE TRAFFIC, HMA SURFACE REMOVAL, PRIME COAT, AND HMA SURFACE COURSE.
- SHORT TERM PAVEMENT MARKING ON MILLED SURFACES SHALL BE PAINT.

- THE CENTERLINE PAVEMENT MARKING SHALL BE REMOVED FROM THE STOP BAR TO THE IMPACT ATTENUATORS OR DRUMS. EDGE LINE PAVEMENT MARKING SHOULD BE REMOVED IF A 10 FOOT LANE WIDTH CANNOT BE MAINTAINED. TEMPORARY EDGE LINES SHALL BE INSTALLED WHEN THE EDGE LINES ARE REMOVED.
- THE CONTRACTORS SHALL PROVIDE INTERNET ACCESSIBILITY TO THE HMA PLAN QUALITY CONTROL LAB SO THAT HMA PLAN REPORTS CAN BE EMAILED TO THE DISTRICT HEADQUARTERS. THIS WORK SHALL BE INCLUDED IN THE COST OF ALL HOT-MIX ASPHALT ITEMS.
- ANY TIME THE CONCRETE BARRIER IS NOT IN THE PROPER POSITION, FLAGGERS SHALL BE IN PLACE TO CONTROL TRAFFIC AND THE TEMPORARY TRAFFIC SIGNALS SHALL BE TURNED OR COVERED.
- AGGREGATE SURFACE COURSE TYPE B SHALL BE CRUSHED STONE OR CRUSHED CONCRETE.
- THE FOLLOWING MIXTURE REQUIREMENTS ARE APPLICABLE FOR THIS PROJECT:

LOCATION	US 36	US 36
MIXTURE USE:	BASE COURSE	SURFACE COURSE
AC/PG:	PG 64-22	PG 64-22
RAP% (MAX):	25%	10%
DESIGN AIR VOIDS:	4.0% @ NDESIGN = 70	4.0% @ NDESIGN = 70
MIXTURE COMPOSITION: (GRADATION MIXTURE)	IL-19.0	IL-9.5
FRICITION AGGREGATE:	N/A	MIXTURE "D"

**COMMITMENTS**

NONE



JOB # 2223.1	DESIGNED - NAK	REVISED -
FILE NAME # 0774165-hst-gennote.dgn	DRAWN - AJH	REVISED -
PLOT SCALE # 2.0000 / in.	CHECKED - NAK	REVISED -
PLOT DATE # 8/11/2014	DATE - 7/12/2010	REVISED -

STATE OF ILLINOIS  
DEPARTMENT OF TRANSPORTATION

INDEX OF SHEETS, HIGHWAY STANDARDS,  
GENERAL NOTES

F.A.P. RTE. 323	SECTION (142BY) BR	COUNTY MOULTRIE	TOTAL SHEETS 35	SHEET NO. 2
FED. ROAD DIST. NO. ILLINOIS FED. AID PROJECT			CONTRACT NO. 74165	

SCALE: SHEET NO. OF SHEETS STA. TO STA.

SUMMARY OF QUANTITIES				CONSTRUCTION CODE			
CODE NO.	ITEM	UNIT	TOTAL QUANTITY	SN 070-2018	SN 070-2018		
				RURAL	RURAL		
				0011	0021		
20200100	EARTH EXCAVATION	CU YD	310	310			
20400800	FURNISHED EXCAVATION	CU YD	160	160			
20700220	POROUS GRANULAR EMBANKMENT	CU YD	453	453			
25100630	EROSION CONTROL BLANKET	SQ YD	189	189			
28000250	TEMPORARY EROSION CONTROL SEEDING	POUND	25	25			
28000305	TEMPORARY DITCH CHECKS	FOOT	64	64			
28000400	PERIMETER EROSION BARRIER	FOOT	141	141			
28000500	INLET AND PIPE PROTECTION	EACH	1	1			
28100107	STONE RIPRAP, CLASS A4	SQ YD	138	138			
28200200	FILTER FABRIC	SQ YD	138	138			
31101400	SUB-BASE GRANULAR MATERIAL, TYPE B 6"	SQ YD	354	354			
35501310	HOT-MIX ASPHALT BASE COURSE, 8"	SQ YD	71	71			
35501332	HOT-MIX ASPHALT BASE COURSE, 12"	SQ YD	928	928			
40200800	AGGREGATE SURFACE COURSE, TYPE B	TON	8	8			
40600275	BITUMINOUS MATERIALS (PRIME COAT)	POUND	747	747			

SUMMARY OF QUANTITIES				CONSTRUCTION CODE			
CODE NO.	ITEM	UNIT	TOTAL QUANTITY	SN 070-2018	SN 070-2018		
				RURAL 0011	RURAL 0021		
40600990	TEMPORARY RAMP	SQ YD	56	56			
40603340	HOT-MIX ASPHALT SURFACE COURSE, MIX "D", N70	TON	40	40			
40800050	INCIDENTAL HOT-MIX ASPHALT SURFACING	TON	14	14			
44000100	PAVEMENT REMOVAL	SQ YD	134	134			
44004250	PAVED SHOULDER REMOVAL	SQ YD	225	225			
48203029	HOT-MIX ASPHALT SHOULDERS, 8"	SQ YD	307	307			
50100100	REMOVAL OF EXISTING STRUCTURES	EACH	1	1			
50105220	PIPE CULVERT REMOVAL	FOOT	52	52			
50800105	REINFORCEMENT BARS	POUND	37,580	37,580			
50800515	BAR SPLICERS	EACH	142	142			
51500100	NAME PLATES	EACH	1	1			
54003000	CONCRETE BOX CULVERTS	CU YD	198.5	198.5			
54214503	PRECAST REINFORCED CONCRETE FLARED END SECTIONS, EQUIVALENT ROUND-SIZE 18"	EACH	2	2			
* 63000001	STEEL PLATE BEAM GUARD RAIL, TYPE A 6 FOOT POSTS	FOOT	237.5	237.5			

\* SPECIALTY ITEM



JOB # 2223.1  
 FILE NAME \* 0774165-plt-qaou.dgn  
 PLOT SCALE \* 20.0000 ' / in.  
 PLOT DATE \* 8/11/2014

DESIGNED - NAK  
 DRAWN - AJH  
 CHECKED - NAK  
 DATE - 8/25/2010

REVISED -  
 REVISED -  
 REVISED -  
 REVISED -

STATE OF ILLINOIS  
 DEPARTMENT OF TRANSPORTATION

SUMMARY OF QUANTITIES

F.A.P. RTE. 323	SECTION (142BY) BR	COUNTY MOULTRIE	TOTAL SHEETS 35	SHEET NO. 4
FED. ROAD DIST. NO.		ILLINOIS FED. AID PROJECT		

CONTRACT NO. 74165

SUMMARY OF QUANTITIES				CONSTRUCTION CODE					
CODE NO.	ITEM	UNIT	TOTAL QUANTITY	SN 070-2018	SN 070-2018				
				RURAL 0011	RURAL 0021				
* 63000025	STEEL PLATE BEAM GUARD RAIL, ATTACHED TO STRUCTURES	FOOT	62.5	62.5					
* 63100169	TRAFFIC BARRIER TERMINAL, TYPE 1 (SPECIAL) FLARED	EACH	4	4					
63200310	GUARDRAIL REMOVAL	FOOT	226	226					
66600105	FURNISHING AND ERECTING RIGHT-OF-WAY MARKERS	EACH	7	7					
67000400	ENGINEER'S FIELD OFFICE, TYPE A	CAL MO	6	6					
67100100	MOBILIZATION	L SUM	1	1					
70100405	TRAFFIC CONTROL AND PROTECTION, STANDARD 701321	EACH	1	1					
70100450	TRAFFIC CONTROL AND PROTECTION, STANDARD 701201	L SUM	1	1					
70100500	TRAFFIC CONTROL AND PROTECTION, STANDARD 701326	L SUM	1	1					
70103815	TRAFFIC CONTROL SURVEILLANCE	CAL DA	4	4					
70106500	TEMPORARY BRIDGE TRAFFIC SIGNALS	EACH	1	1					
70300100	SHORT-TERM PAVEMENT MARKING	FOOT	224	224					
70300220	TEMPORARY PAVEMENT MARKING - LINE 4"	FOOT	1,779	1,779					
70301000	WORK ZONE PAVEMENT MARKING REMOVAL	SQ FT	42	42					

\* SPECIALTY ITEM



JOB # 2223.1  
 FILE NAME # D774105-ah1-soq.dgn  
 PLOT SCALE # 28.3800 1/1 in.  
 PLOT DATE # 8/11/2014

DESIGNED - NAK  
 DRAWN - AJH  
 CHECKED - NAK  
 DATE - 8/25/2010

REVISED -  
 REVISED -  
 REVISED -  
 REVISED -

STATE OF ILLINOIS  
 DEPARTMENT OF TRANSPORTATION

SUMMARY OF QUANTITIES

F.A.P. RTE.	SECTION	COUNTY	TOTAL SHEETS	SHEET NO.
323	(142BY) BR	MOULTRIE	35	5
FED. ROAD DIST. NO.			ILLINOIS FED. AID PROJECT	
			CONTRACT NO. 74165	

SUMMARY OF QUANTITIES				CONSTRUCTION CODE					
CODE NO.	ITEM	UNIT	TOTAL QUANTITY	SN 070-2018	SN 070-2018				
				RURAL	RURAL				
				0011	0021				
70400100	TEMPORARY CONCRETE BARRIER	FOOT	275	275					
70400200	RELOCATE TEMPORARY CONCRETE BARRIER	FOOT	275	275					
70600250	IMPACT ATTENUATORS, TEMPORARY (NON- REDIRECTIVE), TEST LEVEL 3	EACH	2		2				
70600260	IMPACT ATTENUATORS, TEMPORARY (FULLY REDIRECTIVE, NARROW), TEST LEVEL 3	EACH	1		1				
70600350	IMPACT ATTENUATORS, RELOCATE (NON- REDIRECTIVE), TEST LEVEL 3	EACH	2		2				
* 78001110	PAINT PAVEMENT MARKING - LINE 4"	FOOT	1,779	1,779					
* 78200410	GUARDRAIL MARKERS, TYPE A	EACH	8	8					
* 78201000	TERMINAL MARKER - DIRECT APPLIED	EACH	4	4					
78300100	PAVEMENT MARKING REMOVAL	SQ FT	223	223					
542A5473	PIPE CULVERTS, CLASS A, TYPE 1 EQUIVALENT ROUND-SIZE 18"	FOOT	78	78					
X2501000	SEEDING, CLASS 2 (SPECIAL)	ACRE	0.3	0.3					
X4400196	HOT-MIX ASPHALT SURFACE REMOVAL, SPECIAL	SQ YD	65	65					
X4401198	HOT-MIX ASPHALT SURFACE REMOVAL, VARIABLE DEPTH	SQ YD	477	477					
X7015005	CHANGEABLE MESSAGE SIGN	CAL DA	28	28					
Z0001495	BRIDGE APPROACH SHOULDER REMOVAL	SQ YD	62	62					
X7040125	PINNING TEMPORARY CONCRTE BARRIER	EACH	12	12					

\* SPECIALTY ITEM



JOB # 2223.1  
 FILE NAME = 0774165-shi-soa.dgn  
 PLOT SCALE = 28.2828' / 1" =  
 PLOT DATE = 8/11/2014

DESIGNED - NAK  
 DRAWN - AJH  
 CHECKED - NAK  
 DATE - 8/25/2010

REVISED -  
 REVISED -  
 REVISED -  
 REVISED -

STATE OF ILLINOIS  
 DEPARTMENT OF TRANSPORTATION

SUMMARY OF QUANTITIES

F.A.P. RTE. 323	SECTION (142BY) BR	COUNTY MOULTRIE	TOTAL SHEETS 35	SHEET NO. 6
FED. ROAD DIST. NO.			ILLINOIS FED. AID PROJECT	

CONTRACT NO. 74165

SUMMARY OF QUANTITIES				CONSTRUCTION CODE			
				SN 070-2018	SN 070-2018		
CODE NO.	ITEM	UNIT	TOTAL QUANTITY	RURAL	RURAL		
				0011	0021		
Z0004552	APPROACH SLAB REMOVAL	SQ YD	116	116			
Z0073002	TEMPORARY SOIL RETENTION SYSTEM	SQ FT	307	307			
2							

<b>CEC</b> Civil and Structural Engineering	Cummins	JOB = 2223.1	DESIGNED - NAK	REVISED -
	Engineering	FILE NAME = 0774165-shs-eqp.dgn	DRAWN - AJH	REVISED -
	Corporation	PLOT SCALE = 20.0000 ' / in.	CHECKED - NAK	REVISED -
		PLOT DATE = 8/11/2014	DATE - 8/25/2010	REVISED -

STATE OF ILLINOIS  
DEPARTMENT OF TRANSPORTATION

SUMMARY OF QUANTITIES

F.A.P. RTE.	SECTION	COUNTY	TOTAL SHEETS	SHEET NO.
323	(1420Y) BR	MOULTRIE	35	7
CONTRACT NO. 74165				

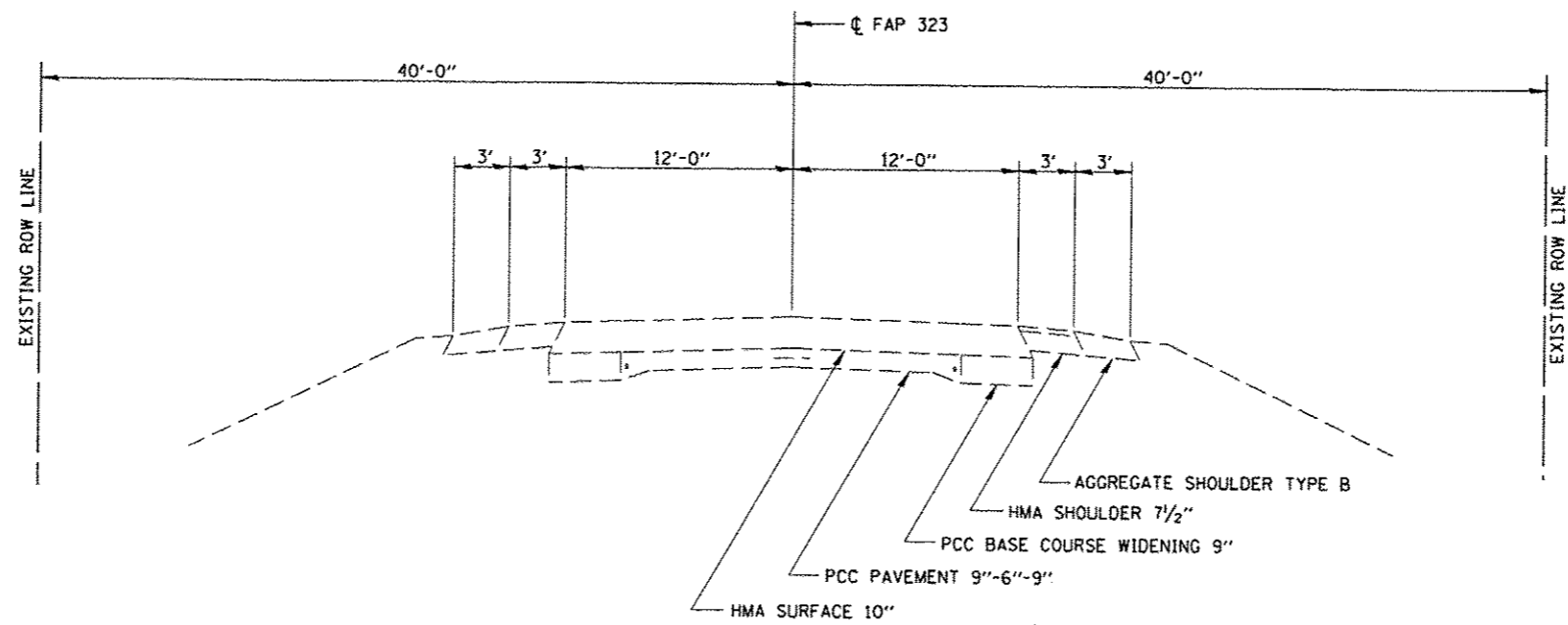

**EXISTING TYPICAL CROSS SECTION**

STA 314+28.25 TO STA 316+38.50  
 STA 317+11.50 TO STA 318+97.50

**BRIDGE OMISSION**  
 STA 316+58.50 TO STA 316+91.50

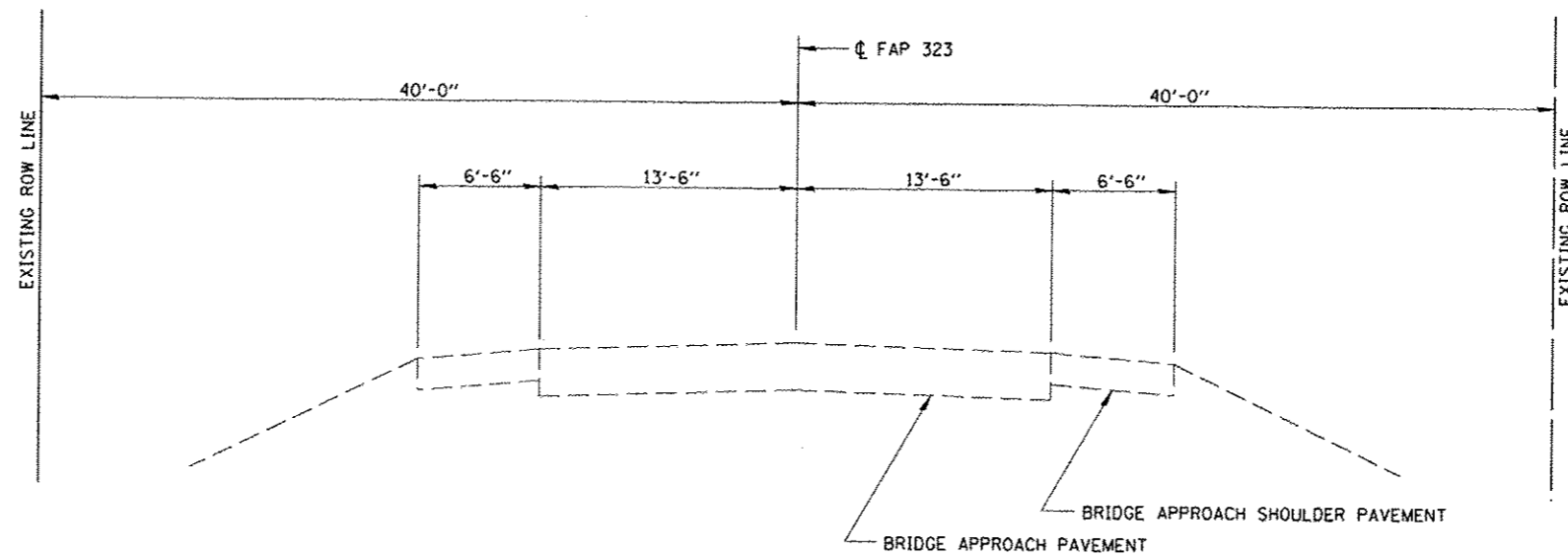

**EXISTING TYPICAL CROSS SECTION**

STA 316+38.50 TO STA 316+58.50  
 STA 316+91.50 TO STA 317+11.50



NOTE 1  
 SEE SHEET 20 FOR LIMITS AND  
 WIDTH OF HMA SHOULDER,  
 EARTH SHOULDER AND  
 LIMITS OF GUARDRAIL

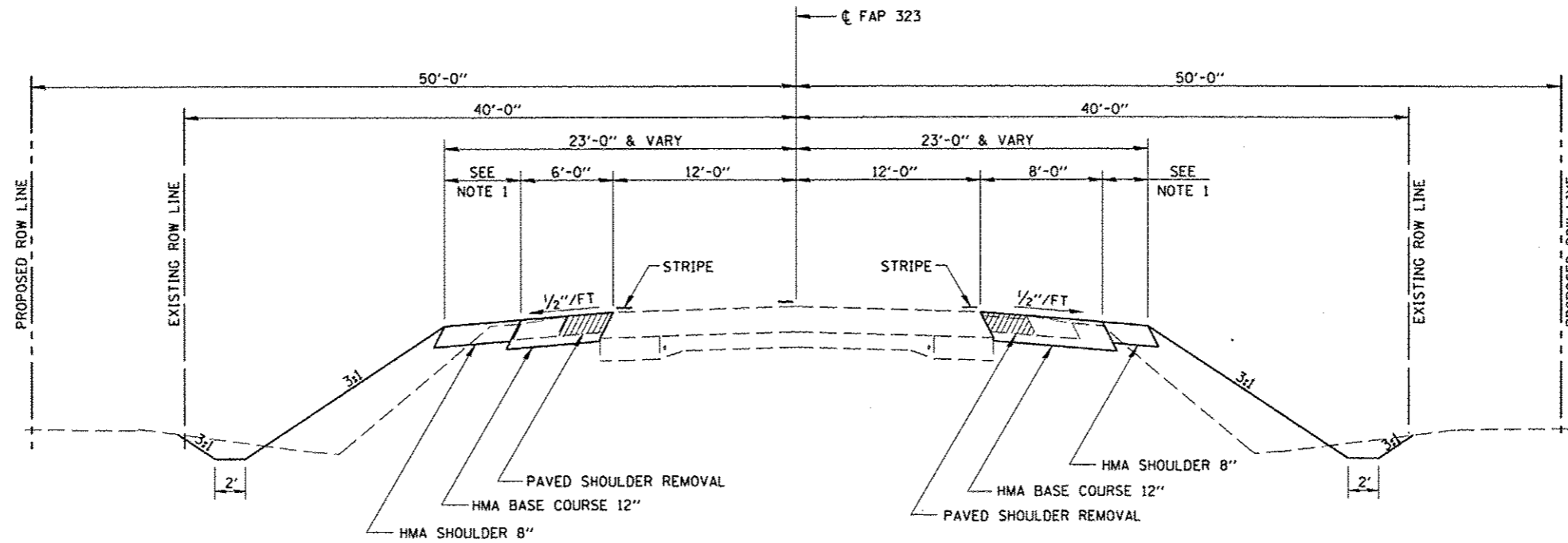

**PROPOSED TYPICAL CROSS SECTION**

RT STA 314+28.25 TO STA 314+56.00  
 STA 314+56.00 TO STA 316+18.50  
 STA 317+31.50 TO STA 318+68.25  
 RT STA 318+68.25 TO STA 318+97.50

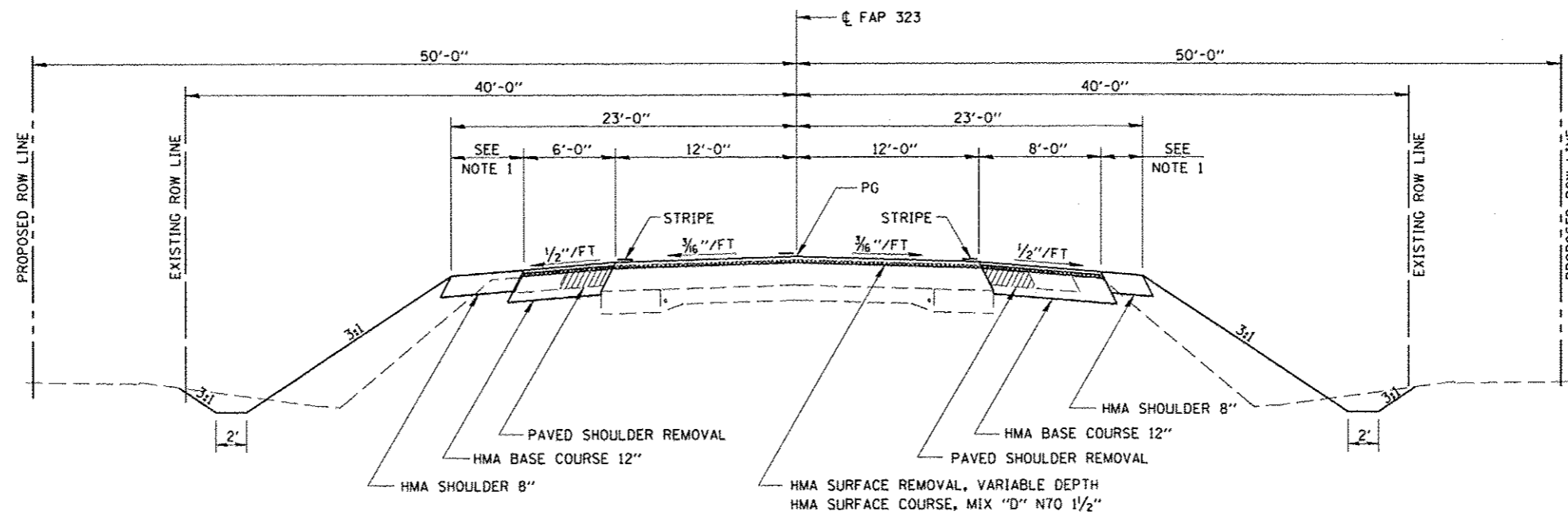

**PROPOSED TYPICAL CROSS SECTION**

STA 316+18.50 TO STA 316+32.00  
 STA 317+11.50 TO STA 317+31.50

NOTE 1  
SEE SHEET 20 FOR LIMITS AND WIDTH OF HMA SHOULDER, EARTH SHOULDER AND LIMITS OF GUARDRAIL

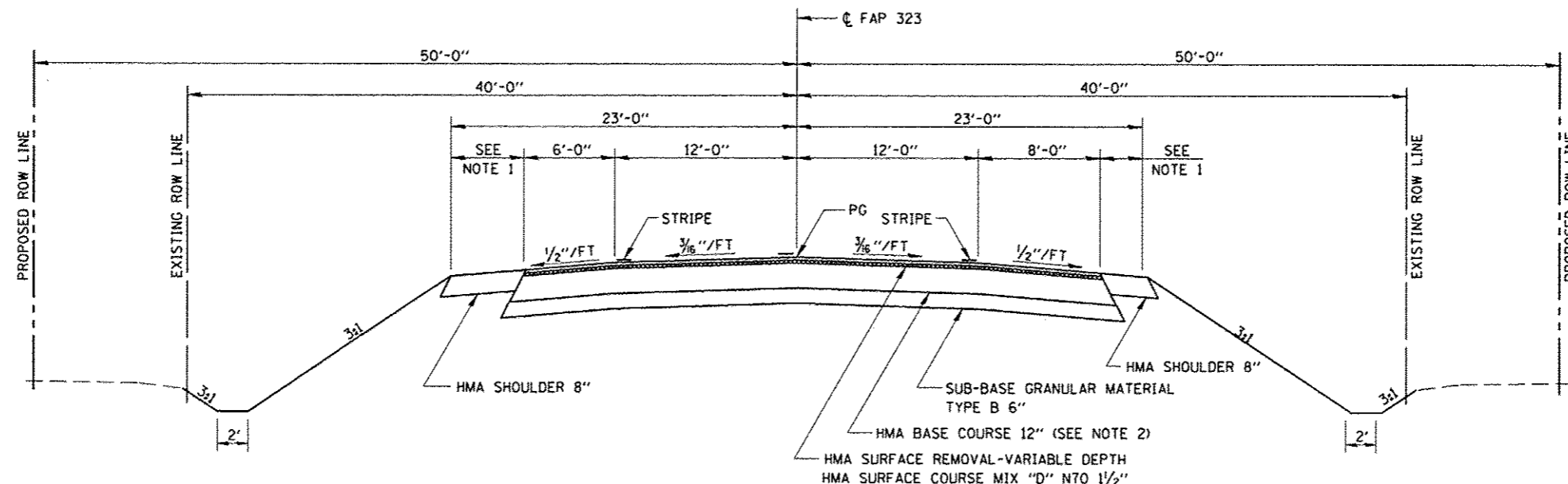

PROPOSED TYPICAL CROSS SECTION  
STA 316+32.00 TO STA 316+58.75  
STA 316+85.25 TO STA 317+11.50

VARIABLE DEPTH MILLING THICKNESS

STA	18' LT	12' LT	CL	12' RT	20' RT
316+18.5	0.12	0.12	0.12	0.12	0.12
316+25	0.14	0.14	0.08	0.16	0.16
316+37.5	0.09	0.09	0.04	0.16	0.16
316+50	0.00	0.00	0.00	0.00	0.00
316+62.5	0.01	0.01	0.01	0.01	0.01
316+75	0.04	0.04	0.04	0.04	0.04
316+87.5	0.08	0.08	0.08	0.08	0.08
317+00	0.03	0.03	0.03	0.03	0.03
317+12.5	0.14	0.14	0.06	0.00	0.00
317+25	0.16	0.16	0.11	0.04	0.04
317+31.5	0.12	0.12	0.12	0.12	0.12

NOTE 2: THE THICKNESS OF THE PROPOSED HMA BASE COURSE PLACED AS PERMANENT PAVEMENT SHALL BE INCREASED BY THE THICKNESS OF THE PROPOSED VARIABLE DEPTH MILLING. COST INCLUDED IN THE COST FOR HMA BASE COURSE 12"

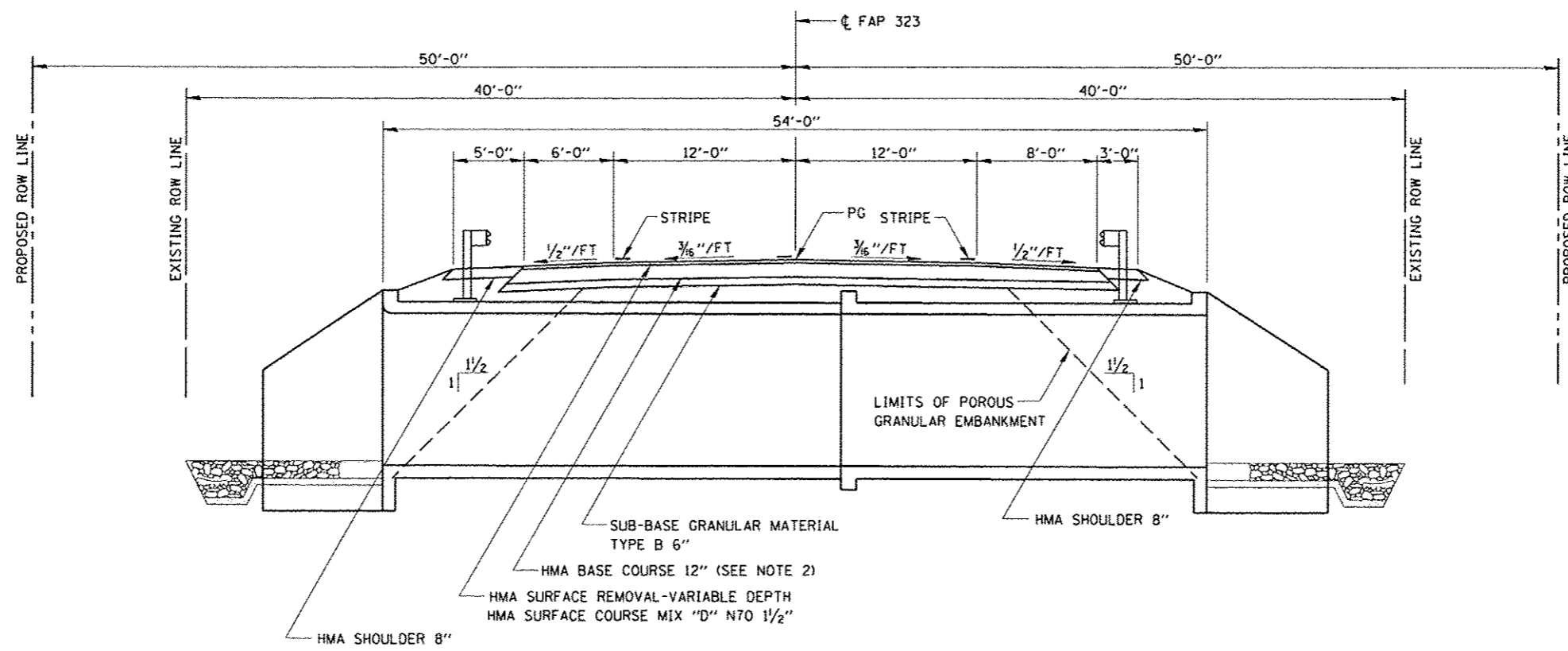

PROPOSED TYPICAL CROSS SECTION  
STA 316+58.75 TO STA 316+85.25

EARTHWORK

LOCATION	EXCAVATION CU YD	EXCAVATION ADJUSTED FOR SHRINKAGE CU YD	EMBANKMENT CU YD	EARTHWORK BALANCE WASTE (+) OR SHORTAGE (-) CU YD
PRELIMINARY PHASE				
LT STA 314+78 TO STA 318+68	65	50	0	50
STAGE 1				
RT STA 314+28 TO STA 318+98	180	135	200	-65
STAGE 2				
LT STA 315+30 TO STA 318+24	65	50	195	-145
TOTAL	310	235	395	-160

WIDENING

LOCATION	SUB-BASE GRANULAR MATERIAL, TYPE B 6"	HOT-MIX ASPHALT BASE COURSE, 12"
	WIDTH SQ YD	WIDTH SQ YD
PRELIMINARY PHASE		
LT STA 314+56.00 TO STA 316+38.50		6' 121.67
LT STA 317+11.50 TO STA 318+68.25		6' 104.50
STAGE 1		
RT STA 314+28.25 TO STA 316+32.00		8' 181.11
RT STA 316+32.00 TO STA 317+11.50	16' 141.33	14' 123.67
RT STA 317+11.50 TO STA 318+97.50		8' 165.33
STAGE 2		
LT STA 316+32.00 TO STA 317+11.50	24' 212.00	24' 212.00
CR 600E		
LT STA 318+23.00 TO STA 318+53.00		6' 20.00
TOTAL	353.33	928.28

BITUMINOUS MATERIALS (PRIME COAT)

LOCATION	TYPE	RATE	APPLICATIONS	SQ FT	POUND
HMA BASE COURSE					
PRELIMINARY PHASE					
LT STA 314+56.00 TO STA 316+38.50	FOG COAT	0.025	2	1,096.03	54.75
LT STA 317+11.50 TO STA 318+68.25	FOG COAT	0.025	2	940.50	47.03
STAGE 1					
RT STA 314+28.25 TO STA 316+32.00	FOG COAT	0.025	2	1,629.99	81.50
RT STA 316+32.00 TO STA 317+11.50	FOG COAT	0.025	2	1,113.03	55.65
RT STA 317+11.50 TO STA 318+97.50	FOG COAT	0.025	2	1,487.97	74.40
STAGE 2					
LT STA 316+32.00 TO STA 317+11.50	FOG COAT	0.025	2	1,908.00	95.40
CR 600E					
LT STA 318+23.00 TO STA 318+53.00	FOG COAT	0.025	2	180.00	9.00
HMA SURFACE COURSE					
FINAL PHASE					
LT STA 316+18.50 TO STA 317+31.50	MILLED	0.05	1	2034.00	101.70
RT STA 316+18.50 TO STA 317+31.50	MILLED	0.05	1	2259.99	113.00
HOT-MIX ASPHALT SHOULDERS, 8"					
LT STA 315+38.80 TO STA 315+59.00	FOG COAT	0.025	1	101.97	2.55
LT STA 315+59.00 TO STA 316+01.10	FOG COAT	0.025	1	317.88	7.95
LT STA 316+01.10 TO STA 317+76.10	FOG COAT	0.025	1	874.98	21.87
LT STA 317+76.10 TO STA 318+18.00	FOG COAT	0.025	1	316.35	7.91
LT STA 318+18.00 TO STA 318+23.10	FOG COAT	0.025	1	25.74	0.64
RT STA 315+07.80 TO STA 315+24.00	FOG COAT	0.025	1	65.61	1.64
RT STA 315+24.00 TO STA 315+65.90	FOG COAT	0.025	1	232.56	5.81
RT STA 315+65.90 TO STA 317+40.90	FOG COAT	0.025	1	524.97	13.12
RT STA 317+40.90 TO STA 317+83.00	FOG COAT	0.025	1	233.64	5.84
RT STA 317+83.00 TO STA 317+99.20	FOG COAT	0.025	1	65.61	1.64
TOTAL					701.40

HOT-MIX ASPHALT SHOULDERS, 8"

LOCATION	WIDTH	SQ YD
LT STA 315+38.80 TO STA 315+59.00	0.0 TO 10.1	11.33
LT STA 315+59.00 TO STA 316+01.10	10.1 TO 5.0	35.32
LT STA 316+01.10 TO STA 317+76.10	5.0 TO 5.0	97.22
LT STA 317+76.10 TO STA 318+18.00	5.0 TO 10.1	35.15
LT STA 318+18.00 TO STA 318+23.10	10.1 TO 0.0	2.86
RT STA 315+07.80 TO STA 315+24.00	0.0 TO 8.1	7.29
RT STA 315+24.00 TO STA 315+65.90	8.1 TO 3.0	25.84
RT STA 315+65.90 TO STA 317+40.90	3.0 TO 3.0	58.33
RT STA 317+40.90 TO STA 317+83.00	3.0 TO 8.1	25.96
RT STA 317+83.00 TO STA 317+99.20	8.1 TO 0.0	7.29
TOTAL		306.59

RESURFACING

LOCATION	HOT-MIX ASPHALT SURFACE COURSE, MIX "D", N70
	WIDTH TON
FINAL PHASE	
LT STA 316+18.50 TO STA 317+31.50	18' 18.98
RT STA 316+18.50 TO STA 317+31.50	20' 21.09
TOTAL	40.07

GUARDRAIL REMOVAL

LOCATION	FOOT
LT STA 316+18.50 TO STA 317+31.50	113
RT STA 316+18.50 TO STA 317+31.50	113
TOTAL	226

STEEL PLATE BEAM GUARD RAIL, TYPE A

LOCATION	FOOT
LT STA 316+13.60 TO STA 316+54.23	40.625
LT STA 316+85.48 TO STA 317+63.60	78.125
RT STA 315+78.40 TO STA 316+56.53	78.125
RT STA 316+87.78 TO STA 317+28.40	40.625
TOTAL	237.50

STEEL PLATE BEAM GUARD RAIL, ATTACHED TO STRUCTURES

LOCATION	FOOT
LT STA 316+54.23 TO STA 316+85.48	31.25
RT STA 316+56.53 TO STA 316+87.78	31.25
TOTAL	62.50

TRAFFIC BARRIER TERMINAL, TYPE 1 (SPECIAL) FLARED

LOCATION	EACH
LT STA 315+63.60 TO STA 316+13.60	1
LT STA 317+63.60 TO STA 318+13.60	1
RT STA 315+28.40 TO STA 315+78.40	1
RT STA 317+28.40 TO STA 317+78.40	1
TOTAL	4

GUARDRAIL MARKERS, TYPE A

LOCATION	EACH
LT STA 316+13.60 TO STA 317+63.60	4
RT STA 315+78.40 TO STA 317+28.40	4
TOTAL	8

TERMINAL MARKER - DIRECT APPLIED

LOCATION	EACH
LT STA 315+63.60	1
LT STA 318+13.60	1
RT STA 315+28.40	1
RT STA 317+78.40	1
TOTAL	4

PIPE CULVERT REMOVAL

LOCATION	FOOT
LT STA 318+13.00 TO STA 318+65.00	52
TOTAL	52

PIPE CULVERTS, CLASS A, TYPE 1 EQUIVALENT ROUND-SIZE 18"

LOCATION	FOOT
LT STA 317+82.00 TO STA 318+60.00	78
TOTAL	78

PRECAST REINFORCED CONCRETE FLARED END SECTIONS, EQUIVALENT ROUND-SIZE 18"

LOCATION	EACH
LT STA 317+75.00	1
LT STA 318+66.00	1
TOTAL	2



JOB # 2223.1  
 FILE NAME = 0774165-shc-achod.dgn  
 PLOT SCALE = 48.8888' / 1" =  
 PLOT DATE = 8/11/2014

DESIGNED - NAK  
 DRAWN - AJH  
 CHECKED - NAK  
 DATE - 8/25/2010

REVISED -  
 REVISED -  
 REVISED -  
 REVISED -

STATE OF ILLINOIS  
 DEPARTMENT OF TRANSPORTATION

SCHEDULE OF QUANTITIES

F.A.P. RTE.	SECTION	COUNTY	TOTAL SHEETS	SHEET NO.
323	(142BY) BR	MOULTRIE	35	11
CONTRACT NO. 74165			ILLINOIS FED. AID PROJECT	



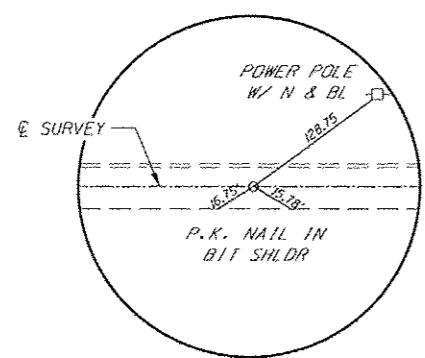
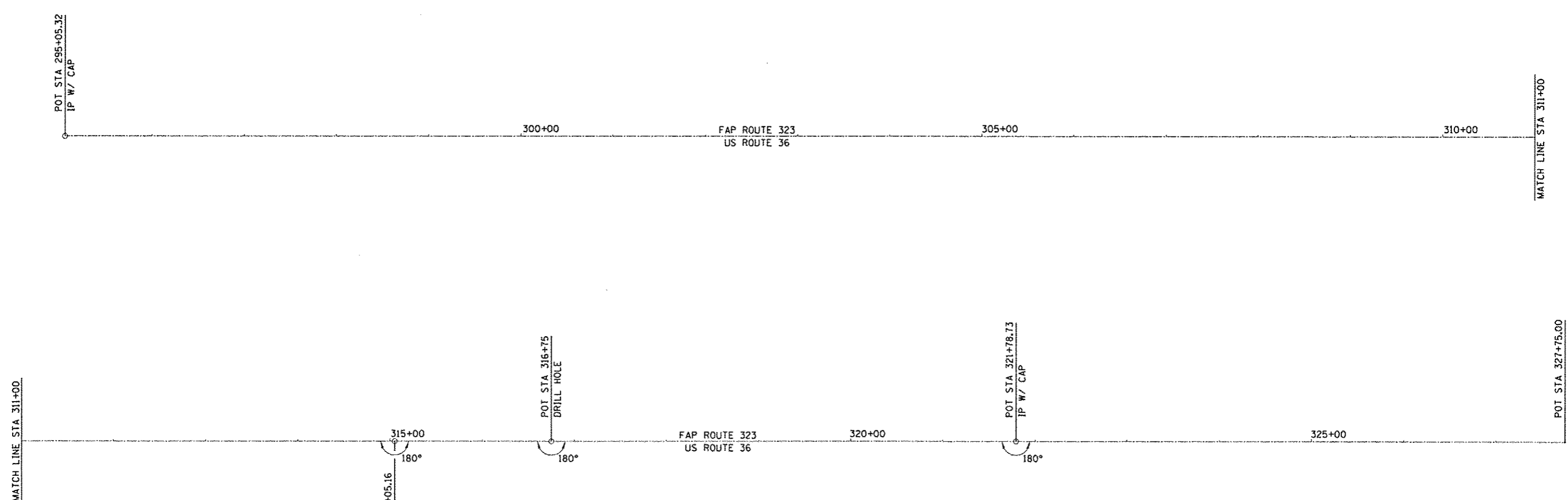

**POT STA 295+05.32**  
**IRON PIN W/ CAP**

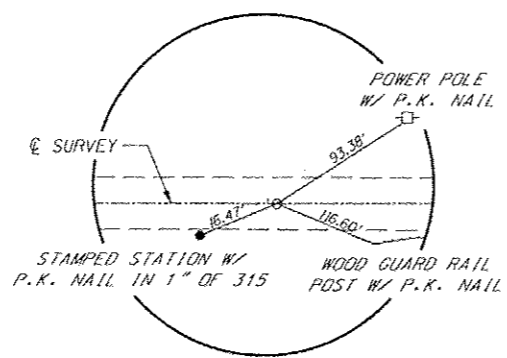

**POT STA 315+05.16**  
**IRON PIN W/ CAP**

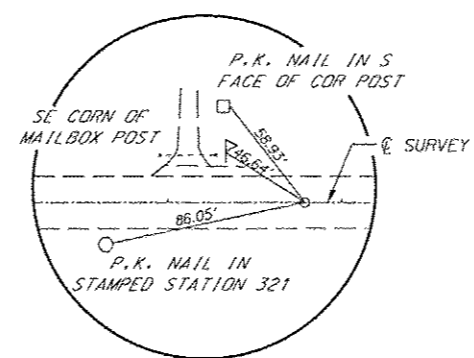

**POT STA 321+78.73**  
**IRON PIN W/ IDOT CAP**

**COORDINATE DATA:**

STA 295+05.32	N	99,980.73
	E	97,760.00
STA 315+05.16	N	99,980.73
	E	99,759.84
STA 316+75.00	N	99,980.73
	E	99,929.68
STA 321+78.73	N	99,980.73
	E	100,433.42
STA 327+75	N	99,980.73
	E	101,029.68



JOB # 2223.1  
FILE NAME = D774165-ahs-ali.dgn  
PLOT SCALE = 1/8"=1'-0"  
PLOT DATE = 8/11/2014

DESIGNED - NAK  
DRAWN - AJH  
CHECKED - NAK  
DATE - 7/12/2010

REVISED -  
REVISED -  
REVISED -  
REVISED -

**STATE OF ILLINOIS**  
**DEPARTMENT OF TRANSPORTATION**

**ALIGNMENT AND CROSS TIES**

F.A.P. RTE.	SECTION	COUNTY	TOTAL SHEETS	SHEET NO.
323	(142BY) BR	MOULTRIE	35	13
FED. ROAD DIST. NO.			ILLINOIS FED. AID PROJECT	

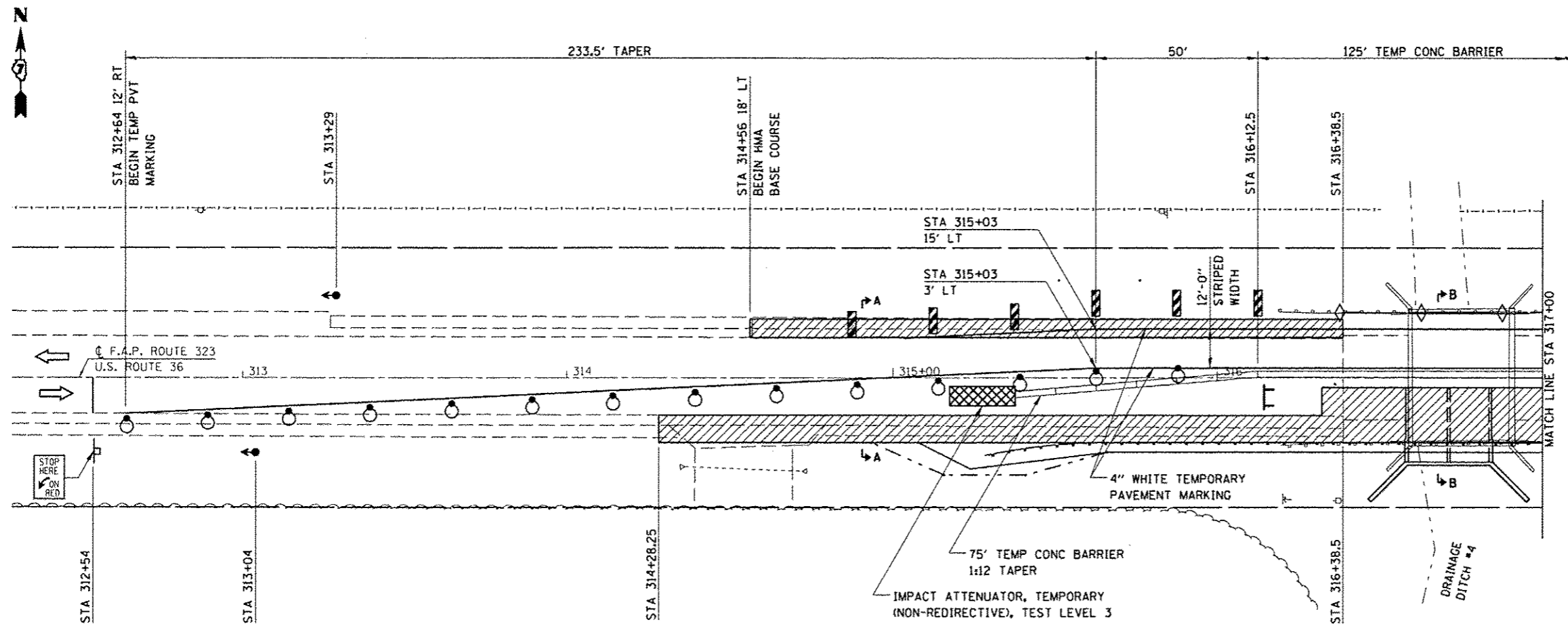

LEGEND	
	TRAFFIC SIGNAL WITH BACKPLATE
	DRUM WITH STEADY BURNING LIGHT
	CRYSTAL/BIDIRECTIONAL BARRIER WALL/GUARDRAIL MARKER
	DOUBLE VERTICAL PANEL
	TYPE III BARRICADE
	IMPACT ATTENUATOR
	HMA BASE COURSE

- GENERAL NOTES**
- SEE STANDARD 701321 FOR DETAILS OF TRAFFIC CONTROL AND PROTECTION NOT SHOWN
  - PLACEMENT AND REMOVAL OF TEMPORARY PAVEMENT MARKINGS - INCLUDED IN THE COST FOR TRAFFIC CONTROL AND PROTECTION STANDARD 701321
  - SEE SHEETS 16-17 FOR SECTION A-A AND B-B
  - DRUMS IN TAPER SHALL BE POSITIONED TO ALLOW ACCESS TO FIELD ENTRANCES ON THE SOUTH SIDE OF US 36

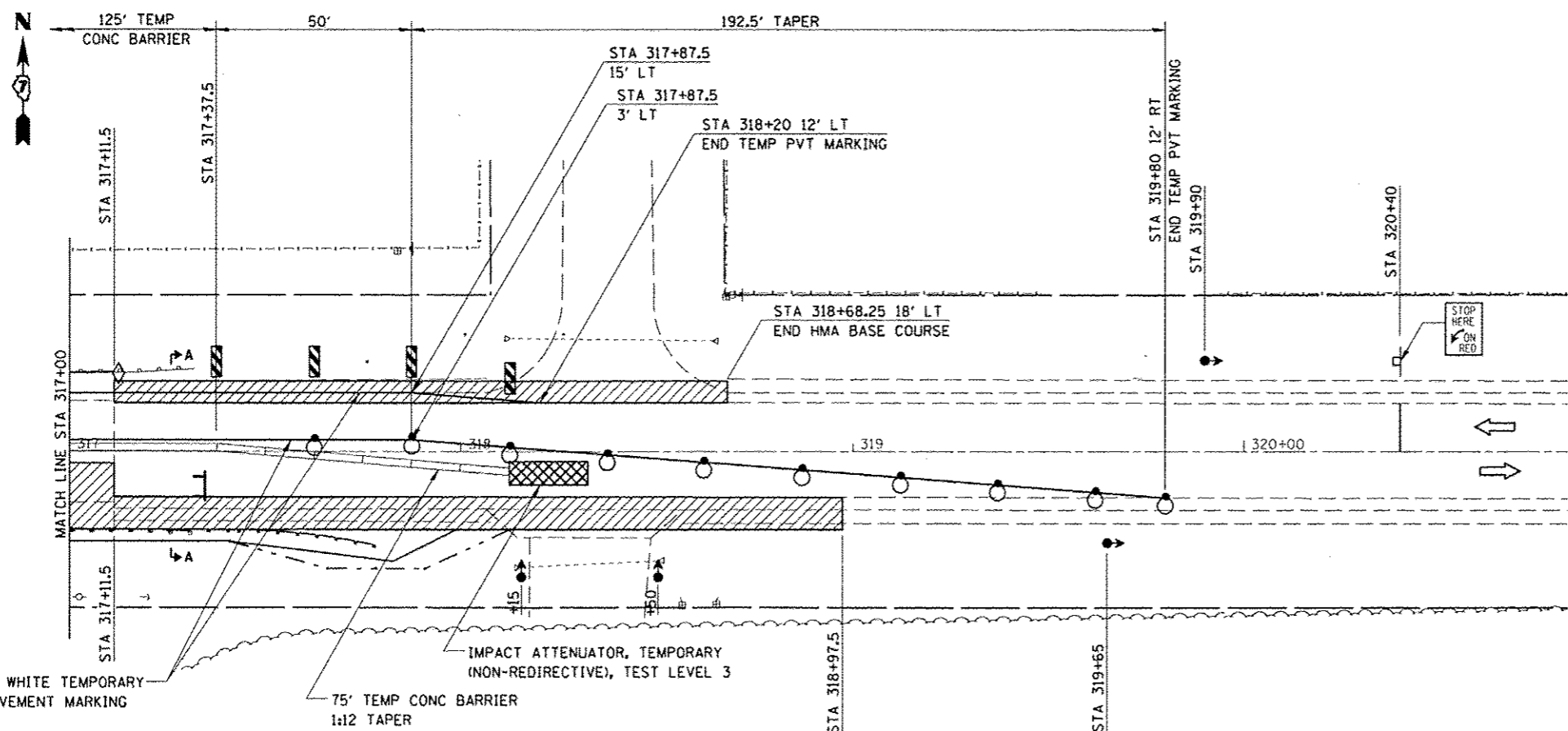

**SEQUENCE OF OPERATIONS**

- PRELIMINARY PHASE**  
 PRELIMINARY PHASE CONSTRUCTION WILL CONSIST OF THE FOLLOWING:
- REMOVE PAVED SHOULDER LEFT STA. 314+78 TO STA. 318+06.5
  - REMOVE PAVEMENT LEFT STA 318+06.5 TO STA 318+68.25
  - CONSTRUCT HMA BASE COURSE LEFT STA 314+78 TO STA 318+68.25
  - INSTALL TRAFFIC CONTROL DEVICES AS SHOWN ON STANDARD 701321 AND AS DETAILED ON THE PLANS.
- STAGE 1**  
 STAGE 1 CONSTRUCTION WILL CONSIST OF THE FOLLOWING:
- REMOVE GUARDRAIL ALONG EASTBOUND LANE
  - REMOVE PAVED SHOULDER RIGHT STA. 314+28.25 TO STA. 318+97.5
  - REMOVE STAGE 1 PORTIONS OF APPROACH SLABS RIGHT STA. 316+38.5 TO STA. 316+58.5 AND RIGHT STA. 316+91.5 TO STA. 317+11.5
  - REMOVE STAGE 1 PORTIONS OF EXISTING BRIDGE RIGHT STA. 316+58.5 TO STA. 316+91.5
  - CONSTRUCT STAGE 1 PORTION OF PROPOSED STRUCTURE
  - CONSTRUCT EMBANKMENT AND EXCAVATE DITCHES RIGHT STA. 314+28.25 TO STA. 318+97.5
  - CONSTRUCT HMA BASE COURSE AND HMA SHOULDER RIGHT STA. 314+28.25 TO STA. 318+97.4
  - INSTALL GUARDRAIL, TERMINALS, AND MARKERS RIGHT STA. 315+28.4 TO STA. 317+78.4



JOB - 2223.1  
 FILE NAME - D774165-ahs-asgl.dgn  
 PLOT SCALE - 48.0000 / 1" = 100'  
 PLOT DATE - 8/11/2014

DESIGNED - NAK  
 DRAWN - AJH  
 CHECKED - NAK  
 DATE - 8/25/2010

REVISED -  
 REVISED -  
 REVISED -  
 REVISED -

STATE OF ILLINOIS  
 DEPARTMENT OF TRANSPORTATION

STAGE 1 TRAFFIC CONTROL AND PROTECTION

SHEET NO. 1 OF 2 SHEETS

F.A.P. RTE.	SECTION	COUNTY	TOTAL SHEETS	SHEET NO.
323	(142BY) BR	MOULTRIE	35	14
FED. ROAD DIST. NO. ILLINOIS FED. AID PROJECT			CONTRACT NO. 74165	

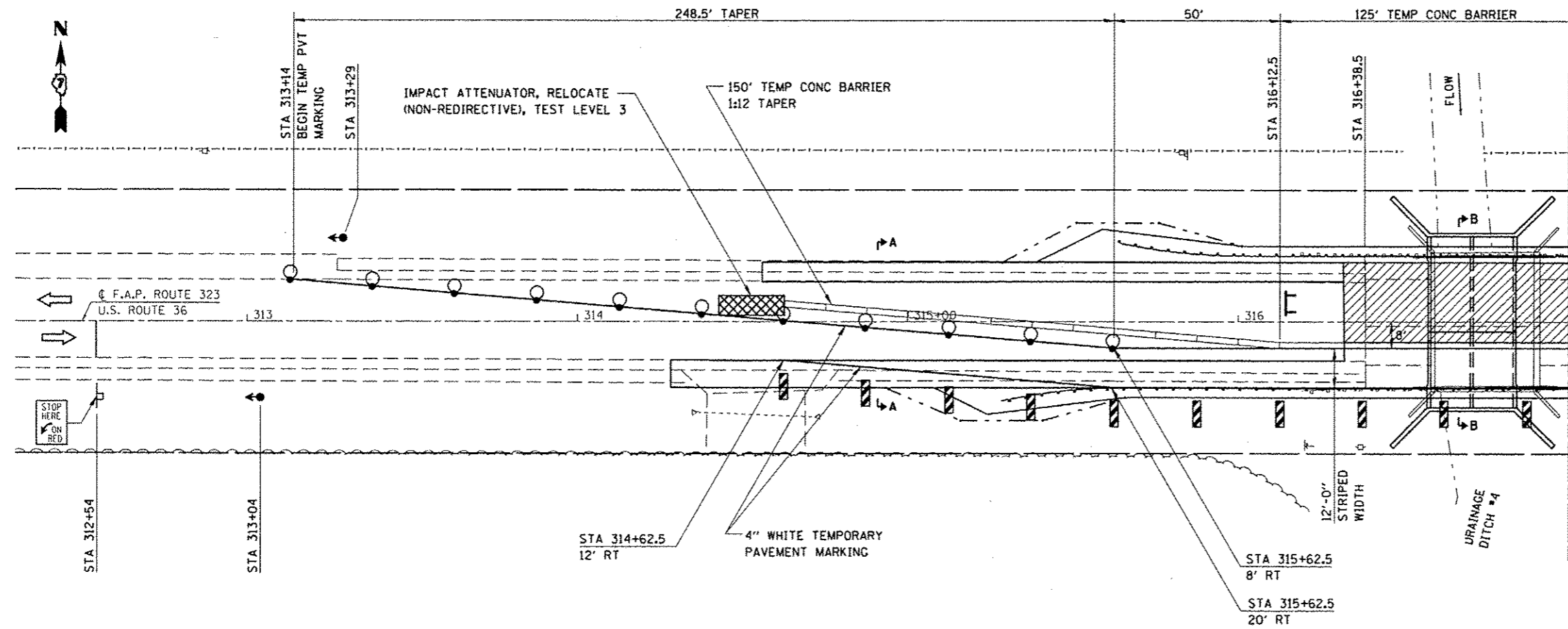

**LEGEND**

- ◀ TRAFFIC SIGNAL WITH BACKPLATE
- ⊙ DRUM WITH STEADY BURNING LIGHT
- ◇ CRYSTAL/BIDIRECTIONAL BARRIER WALL/GUARDRAIL MARKER
- ▨ DOUBLE VERTICAL PANEL
- ⊥ TYPE III BARRICADE
- ▩ IMPACT ATTENUATOR
- ▨ HMA BASE COURSE

- GENERAL NOTES**
- SEE STANDARD 701321 FOR DETAILS OF TRAFFIC CONTROL AND PROTECTION NOT SHOWN
  - PLACEMENT AND REMOVAL OF TEMPORARY PAVEMENT MARKINGS - INCLUDED IN THE COST FOR TRAFFIC CONTROL AND PROTECTION STANDARD 701321
  - ADDITIONAL DRUMS AND TEMPORARY PAVEMENT MARKINGS SHOWN FOR SIDE ROADS SHALL BE INCLUDED IN THE COST FOR TRAFFIC CONTROL AND PROTECTION STANDARD 701321
  - SEE SHEETS 16-17 FOR SECTION A-A AND SECTION B-B

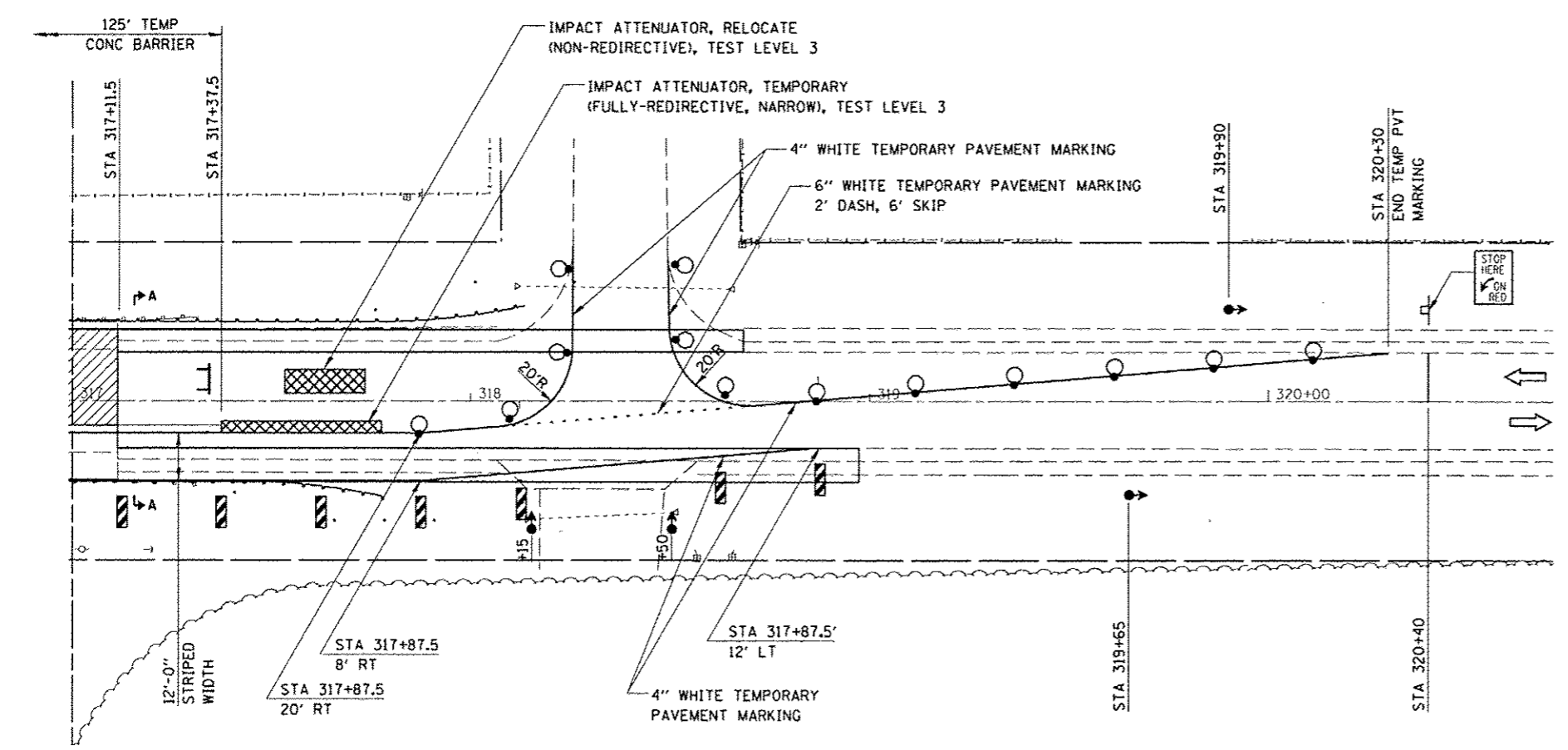

**SEQUENCE OF OPERATIONS**

- STAGE 2**
- STAGE 2 CONSTRUCTION WILL CONSIST OF THE FOLLOWING:
- REMOVE STAGE 1 TEMPORARY MARKINGS AND CONFLICTING EASTBOUND PAVEMENT MARKINGS
  - RELOCATE TRAFFIC CONTROL DEVICES INCLUDING DRUMS, TEMPORARY CONCRETE BARRIER, AND TEMPORARY IMPACT ATTENUATORS.
  - REMOVE GUARDRAIL ALONG WESTBOUND LANE
  - REMOVE STAGE 2 PORTIONS OF APPROACH SLABS LEFT STA. 316+38.5 TO STA. 316+58.5 AND RIGHT STA. 316+91.5 TO STA. 317+11.5
  - REMOVE STAGE 2 PORTIONS OF EXISTING BRIDGE LEFT STA. 316+58.5 TO STA. 318+91.5
  - CONSTRUCT STAGE 2 PORTION OF PROPOSED STRUCTURE
  - EXCAVATE DITCHES AND CONSTRUCT EMBANKMENT LEFT STA. 314+78 TO STA. 318+68.25
  - CONSTRUCT HMA BASE COURSE AND HMA SHOULDERS LEFT STA. 316+38.5 TO STA. 317+11.4
  - INSTALL GUARDRAIL, TERMINALS, AND MARKERS LEFT STA. 315+63.69 TO STA. 318+13.60

- FINAL PHASE**
- FINAL PHASE CONSTRUCTION WILL CONSIST OF THE FOLLOWING:
- REMOVE TEMPORARY MARKINGS
  - REMOVE TRAFFIC CONTROL DEVICES INCLUDING DRUMS, TEMPORARY CONCRETE BARRIER, TEMPORARY IMPACT ATTENUATORS AND TEMPORARY BRIDGE TRAFFIC SIGNALS.
  - INSTALL SHORT TERM PAVEMENT MARKINGS
  - MILL AND RESURFACE ROADWAY AND SHOULDERS
  - INSTALL PAVEMENT MARKINGS

<b>CEC</b> Cummins Engineering Corporation Civil and Structural Engineering	JOB # 2223.1	DESIGNED - NAK	REVISED -	STATE OF ILLINOIS DEPARTMENT OF TRANSPORTATION	STAGE 2 TRAFFIC CONTROL AND PROTECTION	F.A.P. RTE. 323	SECTION (142BY) BR	COUNTY MOULTRIE	TOTAL SHEETS 35	SHEET NO. 15
	FILE NAME = D774165-ah1-stg2.dgn	DRAWN - AJH	REVISED -			SHEET NO. 2 OF 2 SHEETS	FED. ROAD DIST. NO.	ILLINOIS FED. AID PROJECT	CONTRACT NO. 74165	
	PLOT SCALE = 48.0000' / 1"	CHECKED - NAK	REVISED -							
	PLOT DATE = 8/11/2014	DATE = 8/25/2010	REVISED -							

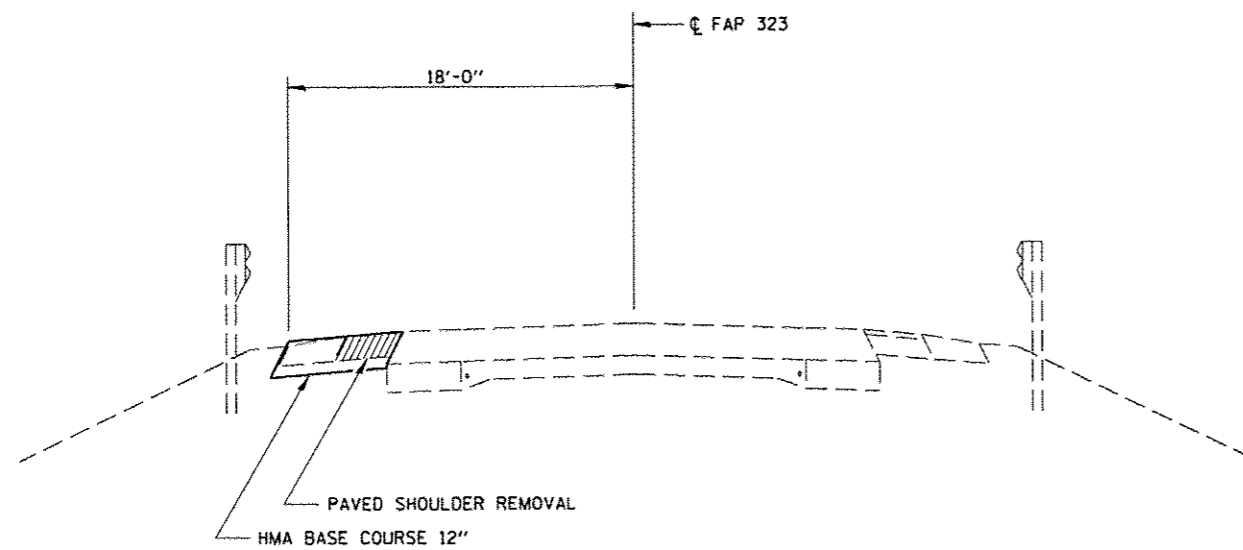

SECTION A-A  
PRELIMINARY PHASE

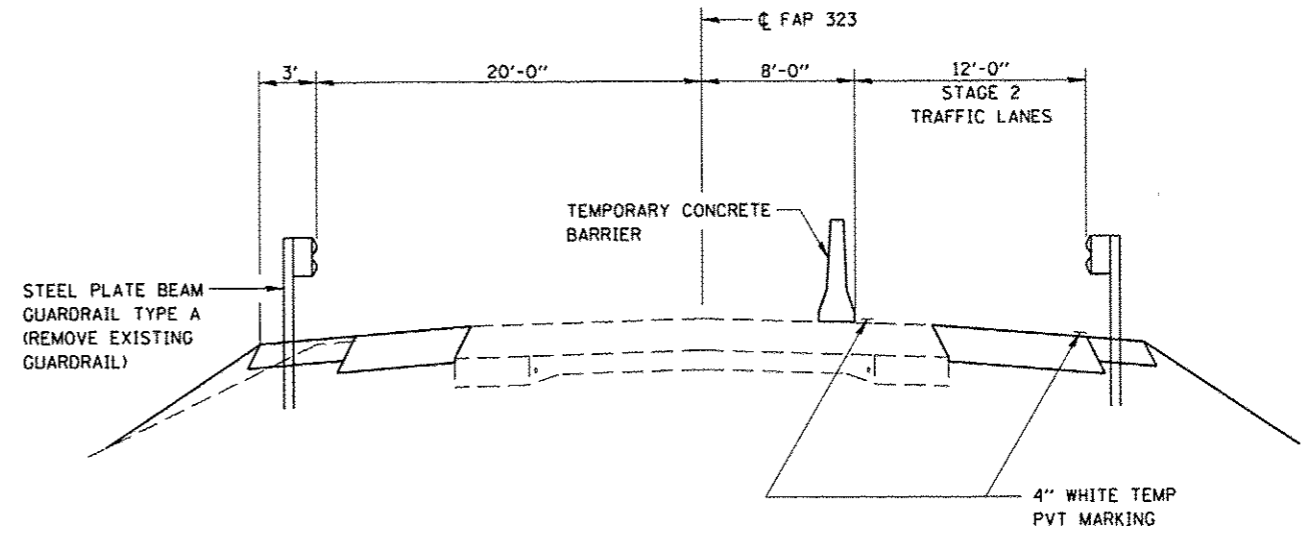

SECTION A-A  
STAGE 2

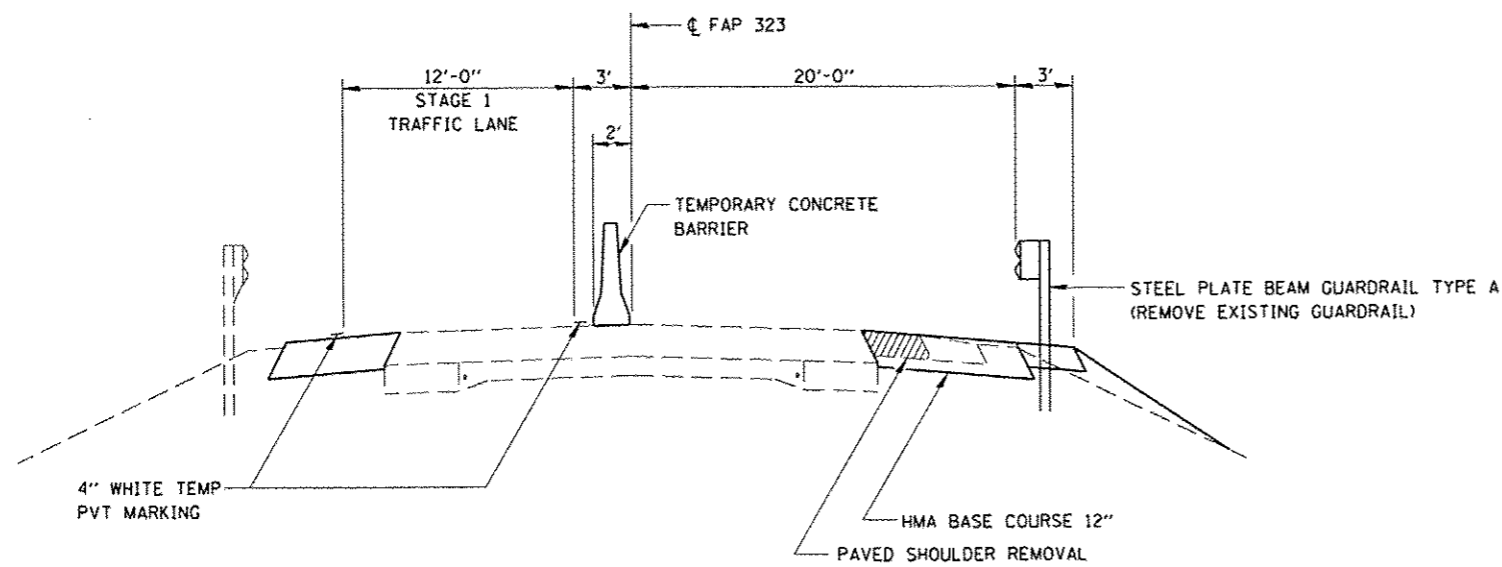

SECTION A-A  
STAGE 1



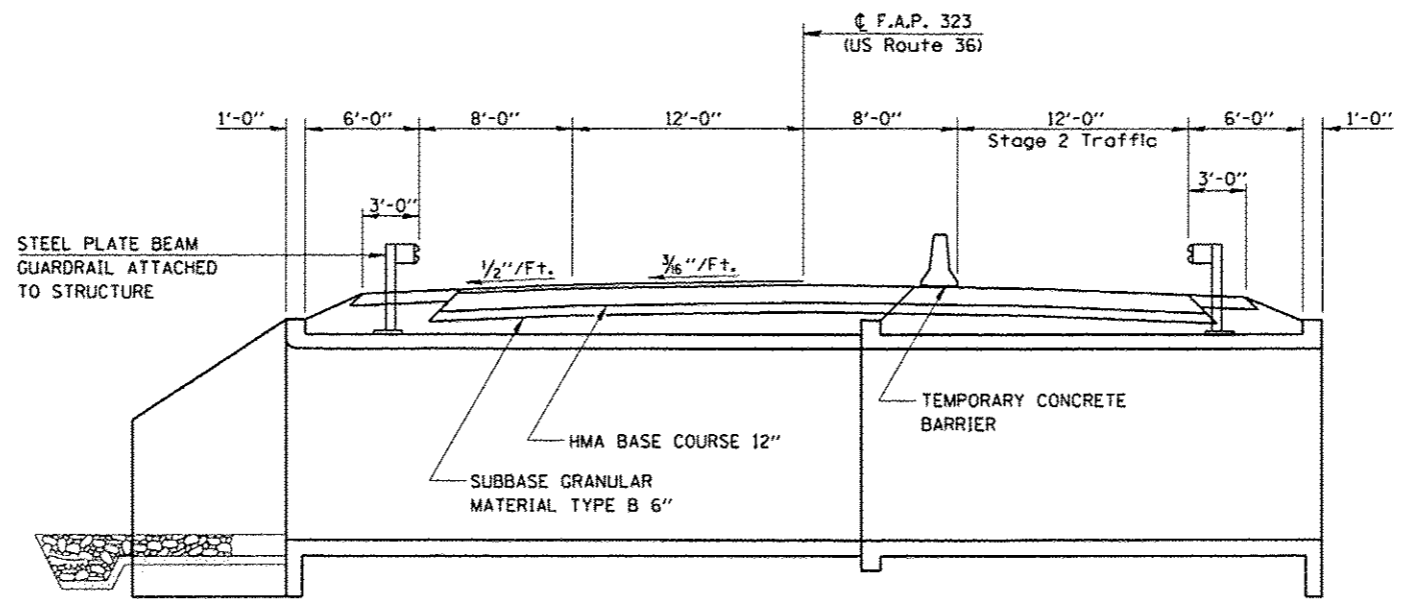

SECTION B-B  
STAGE 2

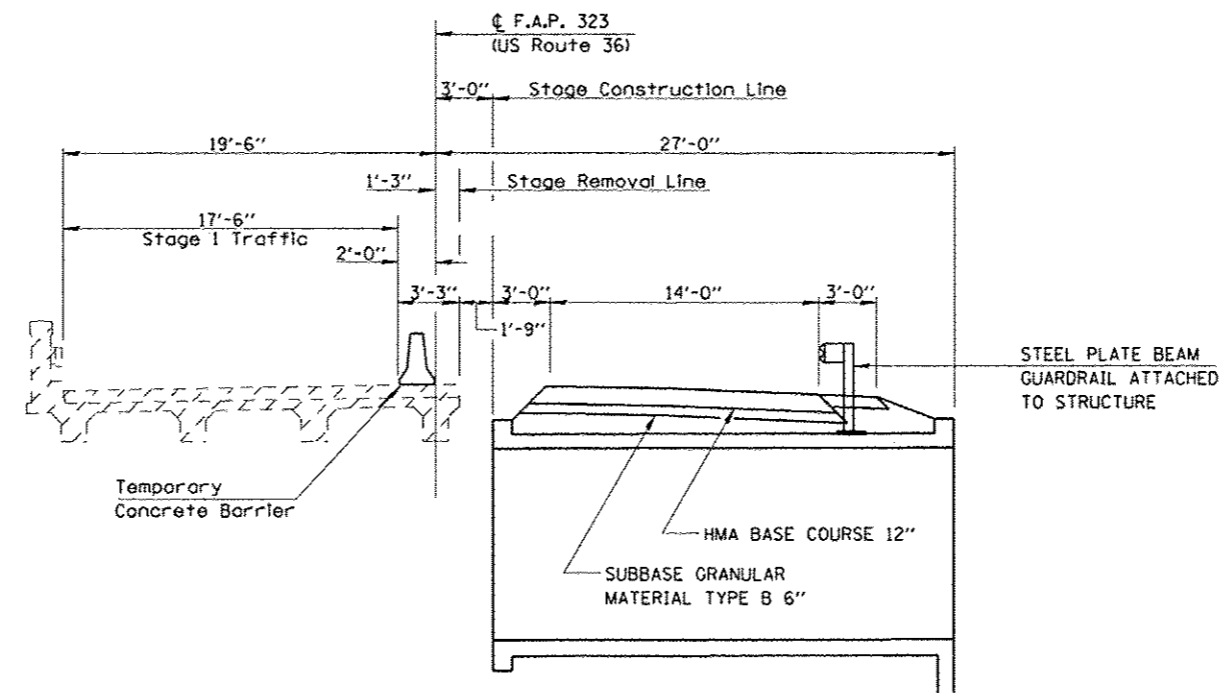

SECTION B-B  
STAGE 1

PLAN  
 DATE  
 BY  
 CHECKED  
 ACCOUNT CHECKED  
 DATE OF MAY CHECKED  
 NO. FILE NAME

PROFILE  
 DATE  
 BY  
 CHECKED  
 ACCOUNT CHECKED  
 DATE OF MAY CHECKED  
 NO. FILE NAME

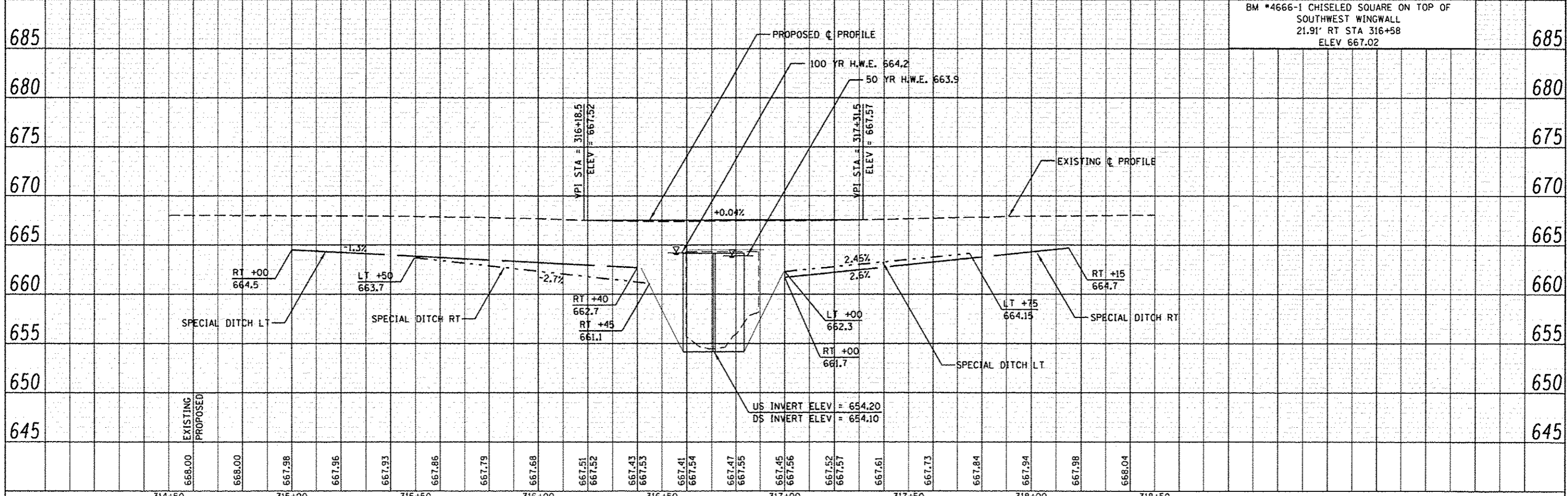
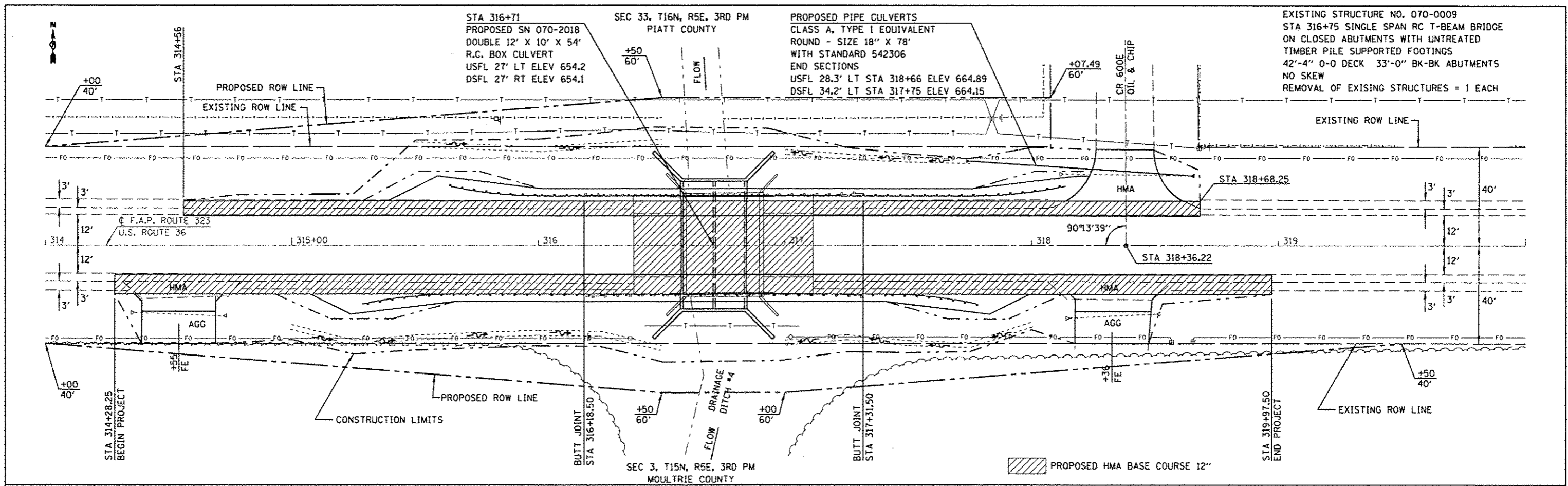

<b>CEC</b> Cummins Engineering Corporation Civil and Structural Engineering	JOB # 2223.1 FILE NAME 0774165-ahs-pp.dgn PLOT SCALE 1/8" = 1'-0" PLOT DATE 8/11/2014	DESIGNED - NAK DRAWN - AJH CHECKED - NAK DATE - 1/12/2011	REVISED - REVISED - REVISED - REVISED -	STATE OF ILLINOIS DEPARTMENT OF TRANSPORTATION	PLAN & PROFILE STA 314+00 TO STA 320+00	F.A.P. RTE. 323 SECTION (142BY) BR COUNTY MOULTRIE TOTAL SHEETS 35 SHEET NO. 18 CONTRACT NO. 74165 ILLINOIS FED. AID PROJECT
--	--	--	--	---	--	--



SEC 33, T16N, R5E, 3RD PM  
PIATT COUNTY

STA 316+75 EXISTING SN 070-0009  
SINGLE SPAN RC DECK GIRDER BRIDGE  
33'-2" BK-BK ABUTMENT  
40'-0" F-F RAIL  
REMOVAL OF EXISTING STRUCTURES = 1 EACH

REMOVE EXISTING 18" CONCRETE  
EQUIVALENT ROUND SIZE PIPE  
CULVERT AND CONCRETE END SECTIONS

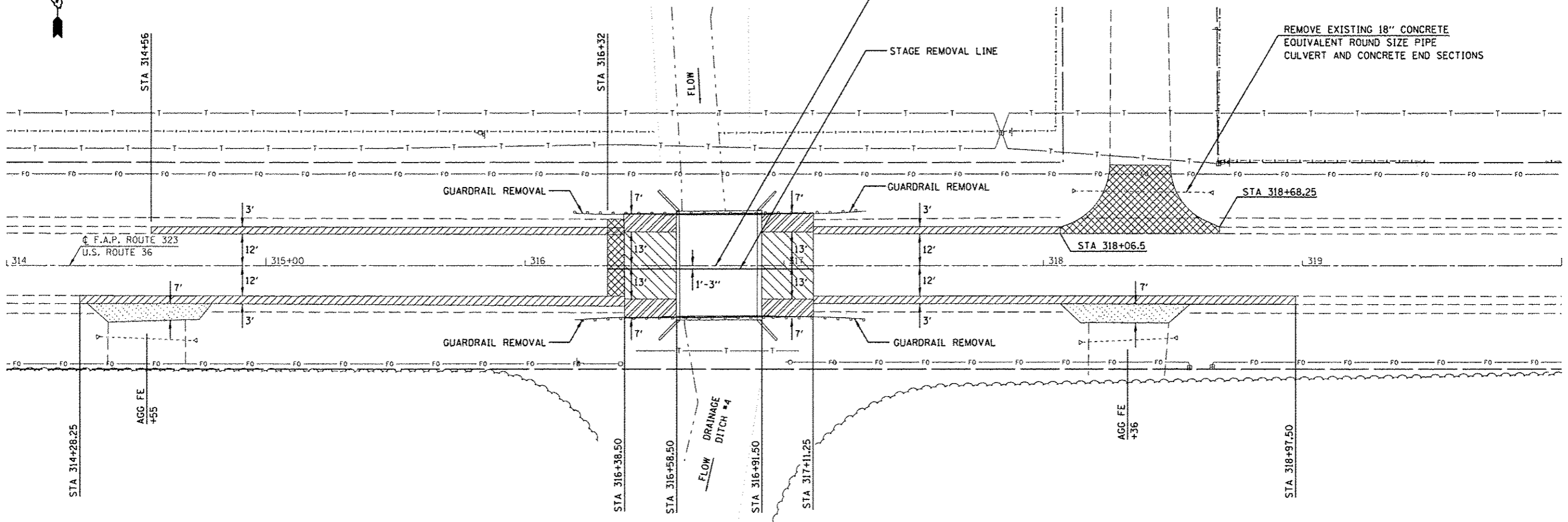

SEC 3, T15N, R5E, 3RD PM  
MOULTRIE COUNTY

- PAVED SHOULDER REMOVAL
- BRIDGE APPROACH SHOULDER REMOVAL
- APPROACH SLAB REMOVAL
- HMA SURFACE REMOVAL
- PAVEMENT REMOVAL

**CEC** Cummins  
Engineering  
Corporation  
Civil and Structural Engineering

JOB # 2223.1  
FILE NAME = 0774165-shs-rm.dgn  
PLOT SCALE = 48.0000' / in.

DESIGNED - NAK  
DRAWN - AJH  
CHECKED - NAK  
DATE - 8/25/2010

REVISED -  
REVISED -  
REVISED -  
REVISED -

STATE OF ILLINOIS  
DEPARTMENT OF TRANSPORTATION

REMOVAL PLAN

STA 314+00 TO STA 320+00

F.A.P. RTE.	SECTION	COUNTY	TOTAL SHEETS	SHEET NO.
323	(142BY) BR	MOULTRIE	35	19
FED. ROAD DIST. NO. ILLINOIS FED. AID PROJECT			CONTRACT NO. 74165	

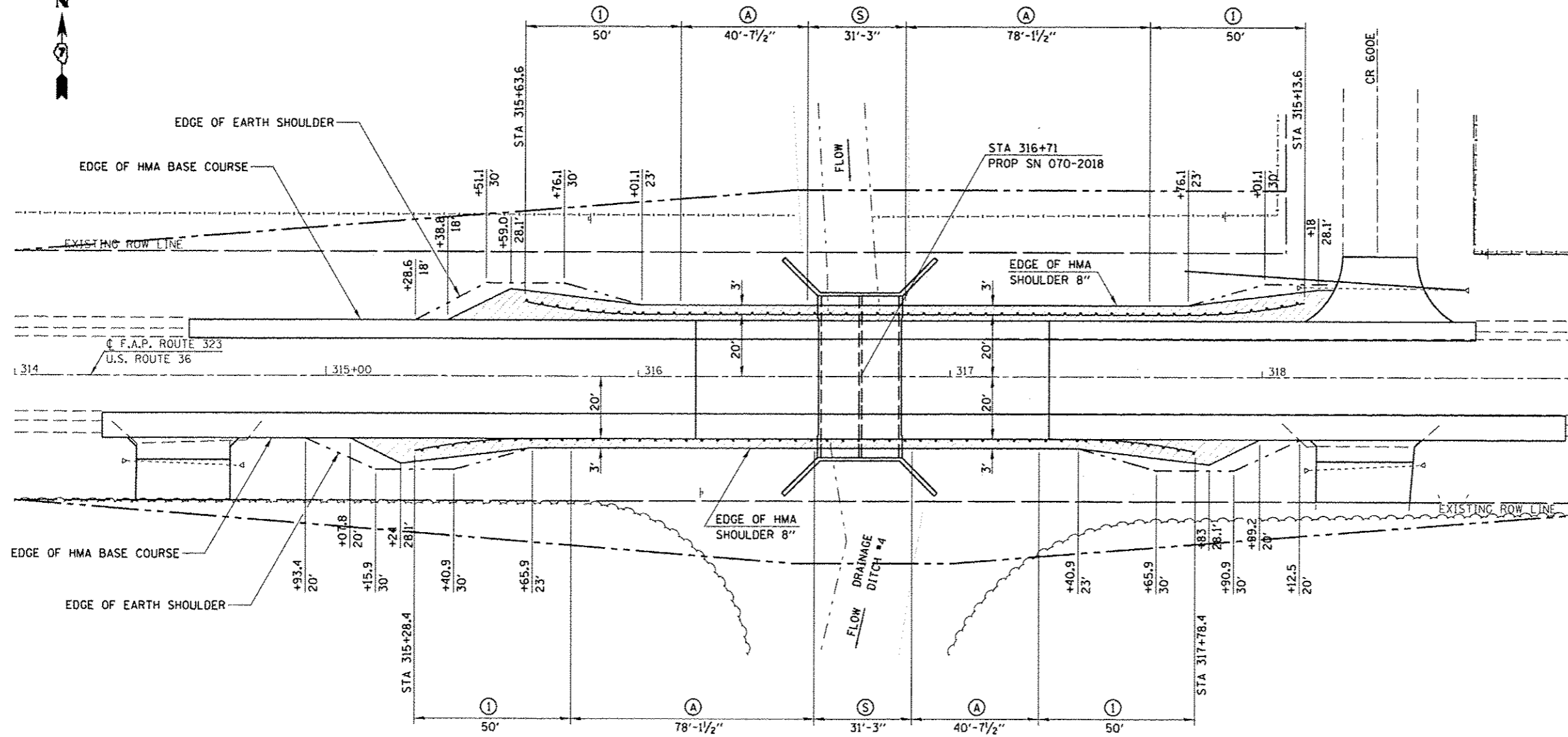

- ① TRAFFIC BARRIER TERMINAL TYPE 1 SPECIAL (FLARED)
- Ⓐ STEEL PLATE BEAM GUARDRAIL TYPE A
- Ⓢ STEEL PLATE BEAM GUARDRAIL ATTACHED TO STRUCTURES

INDICATES LIMITS OF HMA SHOULDER 8''

**NOTES**

1. SEE STANDARD 701301 FOR DETAILS OF SHOULDER WIDENING AT TYPE 1 GUARDRAIL TERMINAL
2. GUARDRAIL SHALL BE ATTACHED TO THE STRUCTURE AS DETAILED ON STANDARD 630101, CASE IV. POST SPACING ON CULVERT SHALL BE 3'-1 1/2''



JOB # 2223.1  
 FILE NAME = D774165-shldr.encl.dgn  
 PLOT SCALE = 48.0000' / 1" = 48.0000'  
 PLOT DATE = 8/11/2014

DESIGNED - NAK  
 DRAWN - AJH  
 CHECKED - NAK  
 DATE - 8/25/2010

REVISED -  
 REVISED -  
 REVISED -  
 REVISED -

**STATE OF ILLINOIS  
 DEPARTMENT OF TRANSPORTATION**

**GUARDRAIL LAYOUT  
 SHOULDER WIDENING**

F.A.P. RTE.	SECTION	COUNTY	TOTAL SHEETS	SHEET NO.
323	(1428Y) BR	MOULTRIE	35	20
CONTRACT NO. 74165				
FED. ROAD DIST. NO. ILLINOIS FED. AID PROJECT				

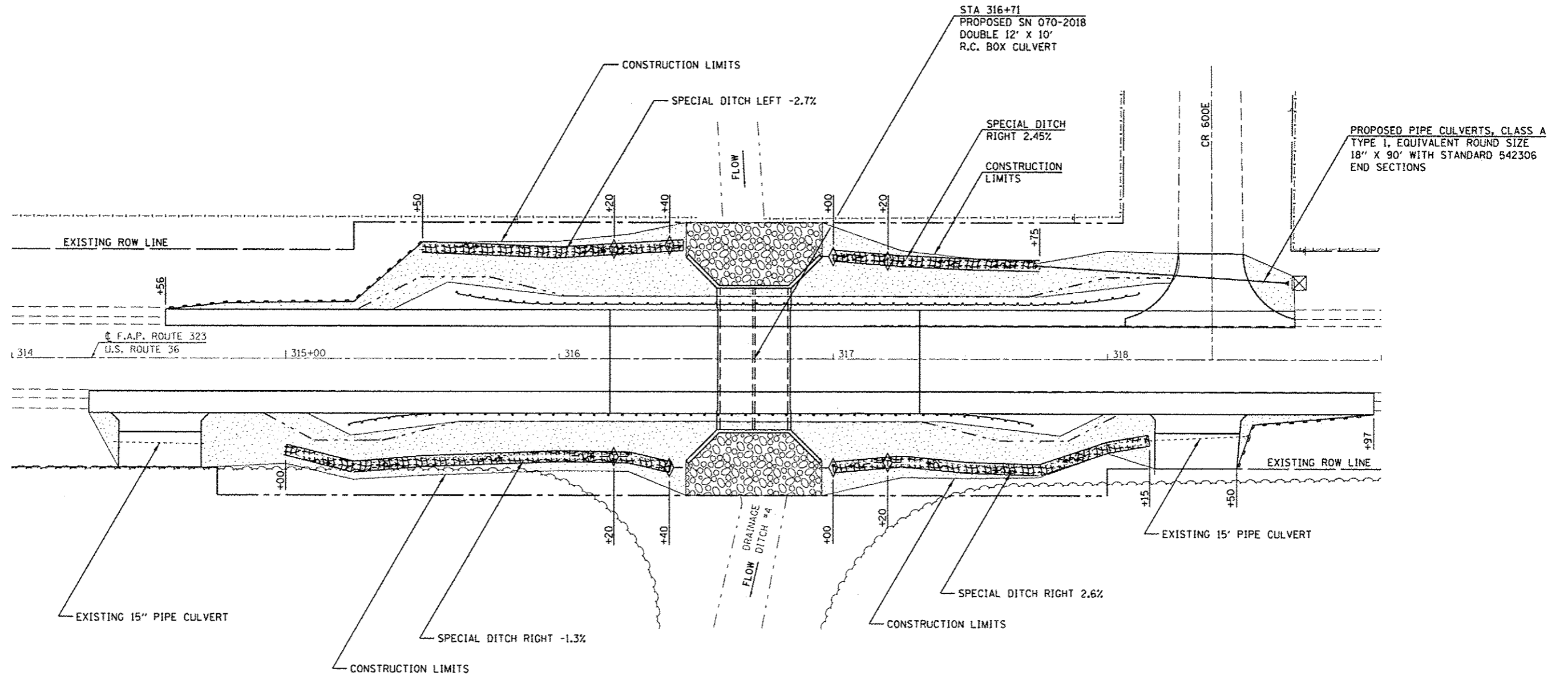

LEGEND	
	STONE RIPRAP CLASS A4
	SEEDING CLASS 2 (SPECIAL)
	EROSION CONTROL BLANKET
	PERIMETER EROSION BARRIER
	INLET & PIPE PROTECTION
	TEMPORARY DITCH CHECKS

**CEC** Cummins  
Engineering  
Corporation  
Civil and Structural Engineering

JOB - 2223.1	DESIGNED - NAK	REVISED -
FILE NAME - 0774165-shd-eroston.dgn	DRAWN - AJH	REVISED -
PLOT SCALE - 48,0000' / 1"	CHECKED - NAK	REVISED -
PLOT DATE - 8/11/2014	DATE - 8/25/2010	REVISED -

STATE OF ILLINOIS  
DEPARTMENT OF TRANSPORTATION

DRAINAGE AND EROSION CONTROL

F.A.P. RTE. 323	SECTION (1428Y) BR	COUNTY MOULTRIE	TOTAL SHEETS 35	SHEET NO. 21
FED. ROAD DIST. NO.		ILLINOIS FED. AID PROJECT		

CONTRACT NO. 74165

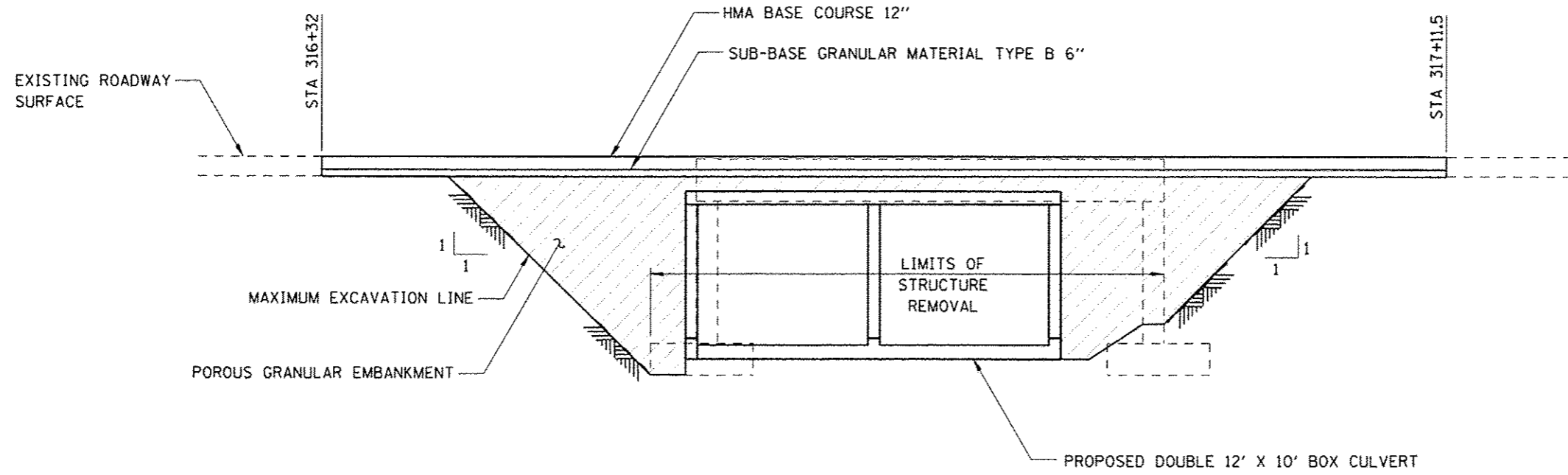

**CULVERT BACKFILL**

SEE SHEET 10 FOR LIMITS  
OF POROUS GRANULAR EMBANKMENT

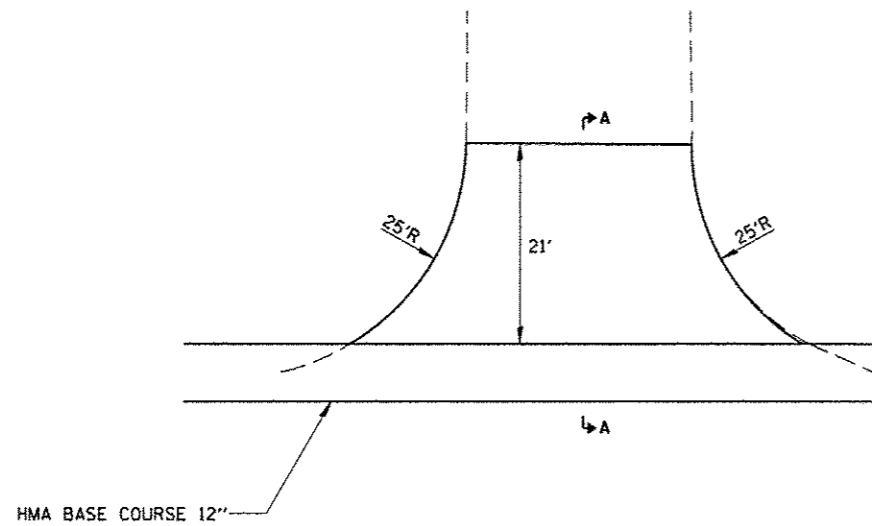

**SIDE ROAD DETAIL**

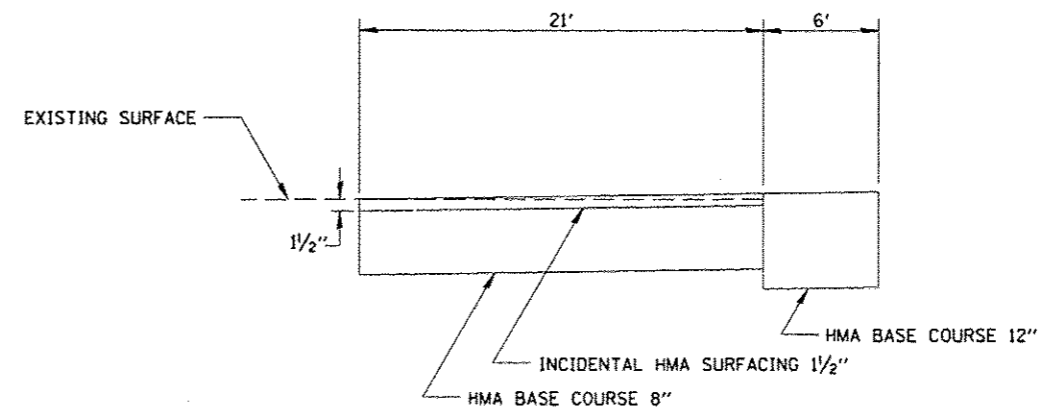

**SECTION A-A**

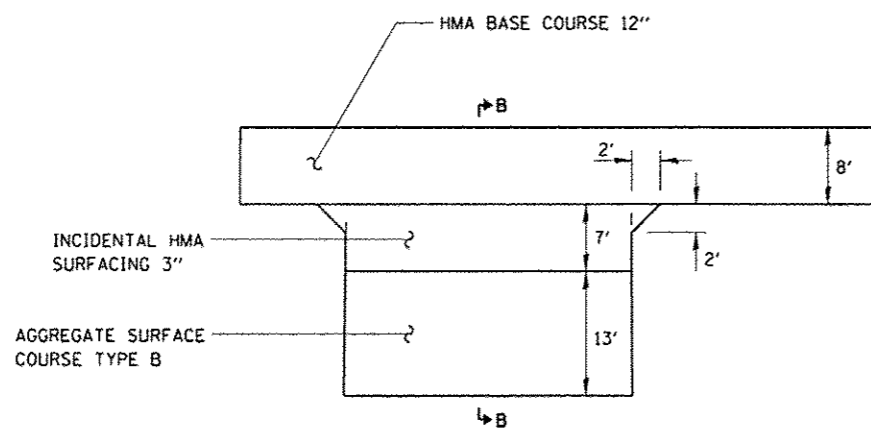

**ENTRANCE DETAIL**

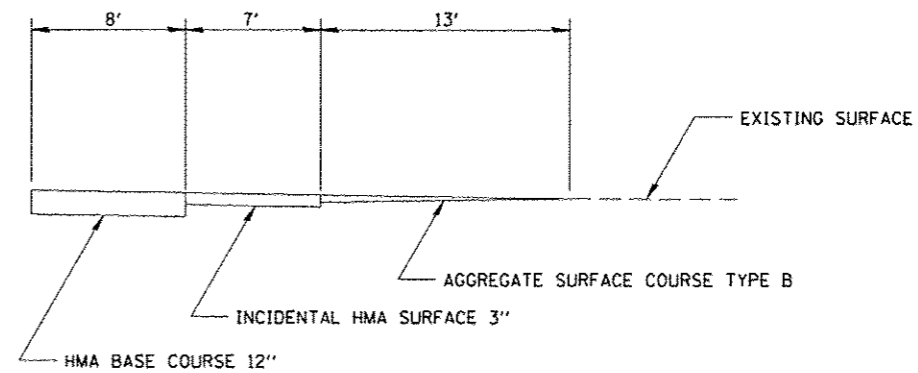

**SECTION B-B**

B.M. #4666-1 Chiseled Square on top of Southwest Wingwall of SN 070-0009, Station 316+58.00, 21.91' Rt., Elev. 667.02

Existing Structure: SN 070-0009, originally built in 1927 as SBI 121, Section 142B at Station 316+75. The existing structure is a single span RC T-beam bridge on closed abutments with untreated timber pile supported footings, 33'-0" bk.-to-bk. of abuts, 42'-4" o.-o. of deck with a clear roadway width of 39'-0". The existing structure will be removed and replaced, in stages, with a double 12'x10' CIP box culvert.

Traffic shall be maintained at all times utilizing Stage Construction.

No Salvage.

D.H.W. Elev. 663.9 (50 Yr.)

Note: Precast culvert option will not be allowed at this site.

**WATERWAY INFORMATION**

		Existing Low Grade Elev. 667.35 ft. @ Sta. 316+56.4		Proposed Low Grade Elev. 667.50 ft. @ Sta. 316+71					
Drainage Area = 10.3 Sq. Mi.									
Flood	Freq. Yr.	Q C.F.S.	Opening Sq. Ft. Exist.	Prop.	Head - Ft. Exist.	Prop.	Headwater El. Exist.	Prop.	
Design	10	534	198	190	662.4	-	0.5	662.4	662.9
Base	50	797	243	226	663.9	0.1	0.7	664.0	664.6
Overtopping	100	905	252	233	664.2	-	1.0	664.2	665.2
Max. Calc.	500	1159	257	240	665.0	0.3	1.9	665.3	666.9

10 year velocity through existing bridge = 2.85 fps  
10 year velocity through proposed culvert = 2.82 fps

**GENERAL NOTES**

1. Layout of slope protection system may be varied in field to suit ground conditions as directed by Engineer.

**APPROVED**

For Structural Adequacy Only

*Michael D. Cummins*  
Engineer of Bridges & Structures

**TOTAL BILL OF MATERIAL**

ITEM	UNIT	QUANTITY
Stone Riprap, Class A4	Sq. Yd.	138
Filter Fabric	Sq. Yd.	138
Removal of Existing Structures	Each	1
Concrete Box Culverts	Cu. Yd.	198.5
Reinforcement Bars	Pound	37580
Temporary Soil Retention System	Sq. Ft.	307
Name Plates	Each	1
Bar Splicers	Each	142

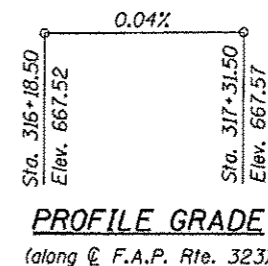

STATION 316+71  
BUILT 20 BY  
STATE OF ILLINOIS  
F.A.P. RTE. 323  
SEC. (142BY)BR  
LOADING HS20  
STR. NO. 070-2018

**NAME PLATE**  
See Std. 515001

**DESIGN SPECIFICATIONS**

2002 AASHTO

**LOADING HS20-44**

Allow 50#/Sq. Ft. for future wearing surface

**DESIGN STRESSES**

$f'_c = 3,500$  psi  
 $f_y = 60,000$  psi (Reinforcement)

**INDEX OF SHEETS**

1. General Plan
2. Stage Construction Details
3. Culvert Details
4. Bar Splicer Assembly Details
5. Temporary Concrete Barrier
- 6-7. Boring Logs

**GENERAL PLAN**  
**US ROUTE 36 OVER DRAINAGE DITCH NO. 4**  
**F.A.P. ROUTE 323 SECTION (142BY)BR**  
**MOULTRIE COUNTY**  
**STATION 316+71**  
**STRUCTURE NO. 070-2018**

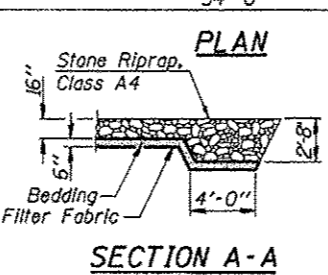
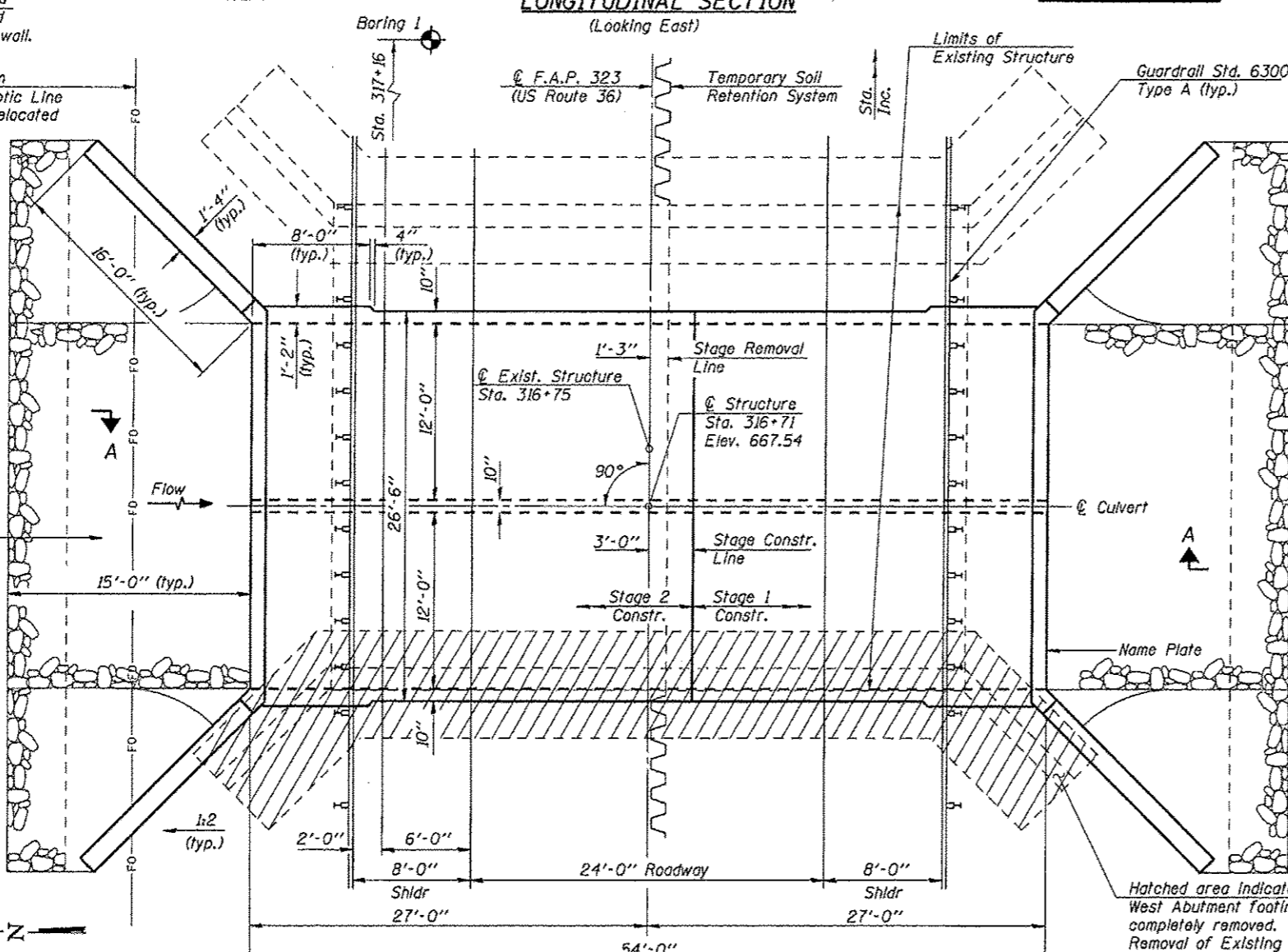
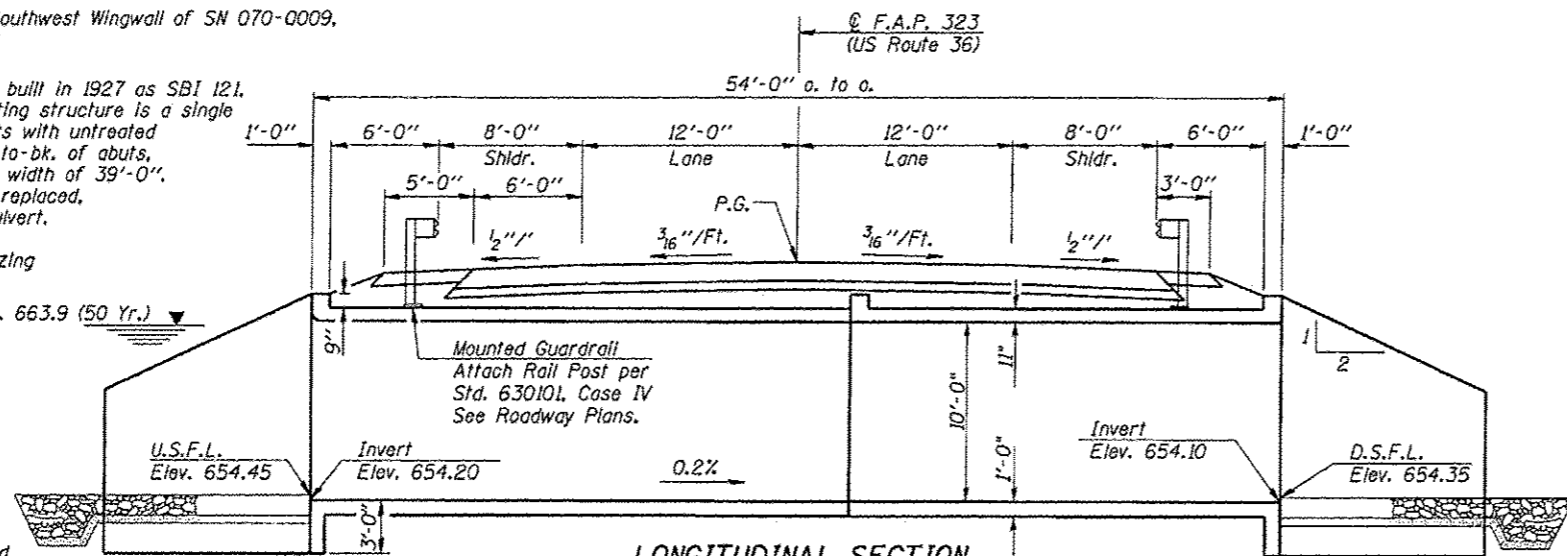

Notch formed by rough finished board attached to and removed with form work, each interior wall. (Do not chamfer).

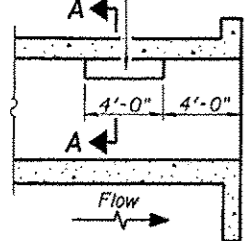

LONGITUDINAL SECTION

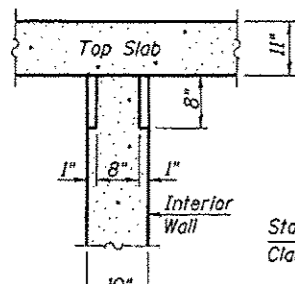

SECTION A-A

**PHOEBE NESTING SITE DETAILS**  
(Downstream End Only)

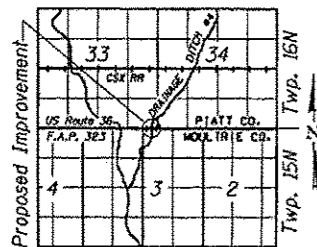

**DESIGN SCOUR ELEVATION TABLE**

Design Scour Elevation (ft.)	US	DS
	651.20	651.10

JOB = 2223.1	DESIGNED A.A.H. & T.S.H.
FILE = 0702018-74185-001-gpe.dgn	CHECKED M.D.C.
DATE = 8/6/2014	DRAWN T.S.H.
	CHECKED M.D.C.

**CEC** Cummins Engineering Corporation  
Civil and Structural Engineering

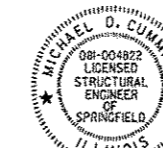

*Michael D. Cummins* (8/6/14)  
(Expires 11/30/2014)

Sheet 1 of 7	F.A.P. RTE. 323	SECTION (142BY)BR	COUNTY MOULTRIE	TOTAL SHEETS 35	SHEET NO. 24
			CONTRACT NO. 74165		
FED. ROAD DIST. NO. 7   ILLINOIS FED. AID PROJECT					



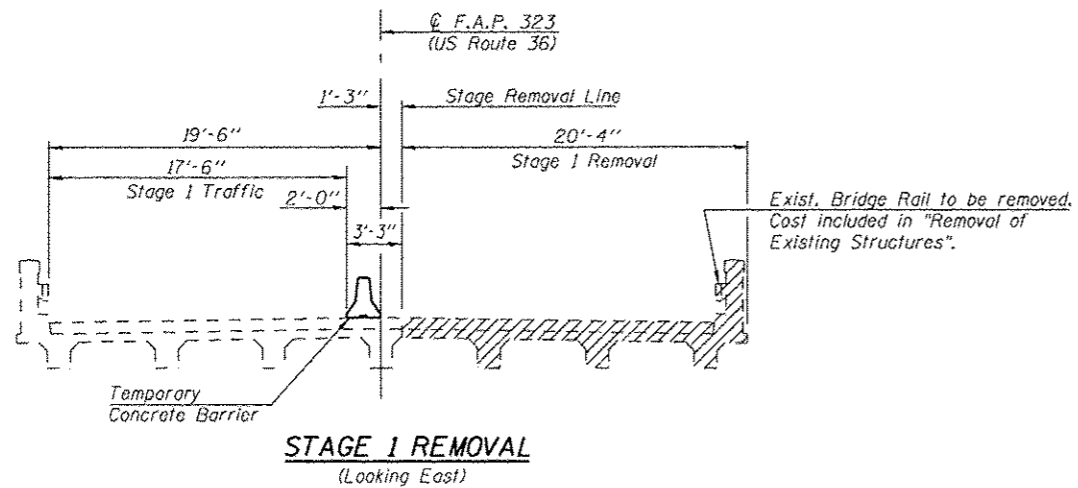

**STAGE 1 REMOVAL**  
(Looking East)

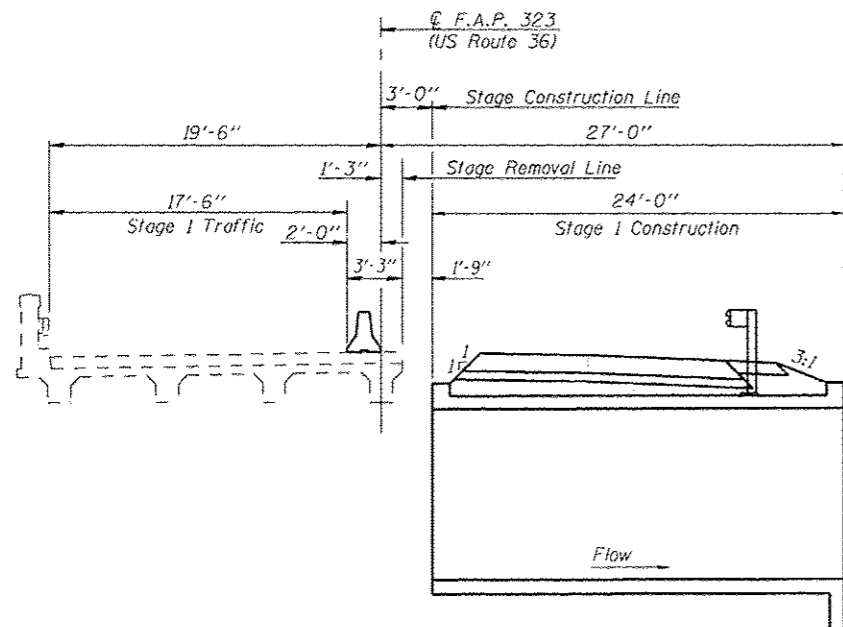

**STAGE 1 CONSTRUCTION**  
(Looking East)

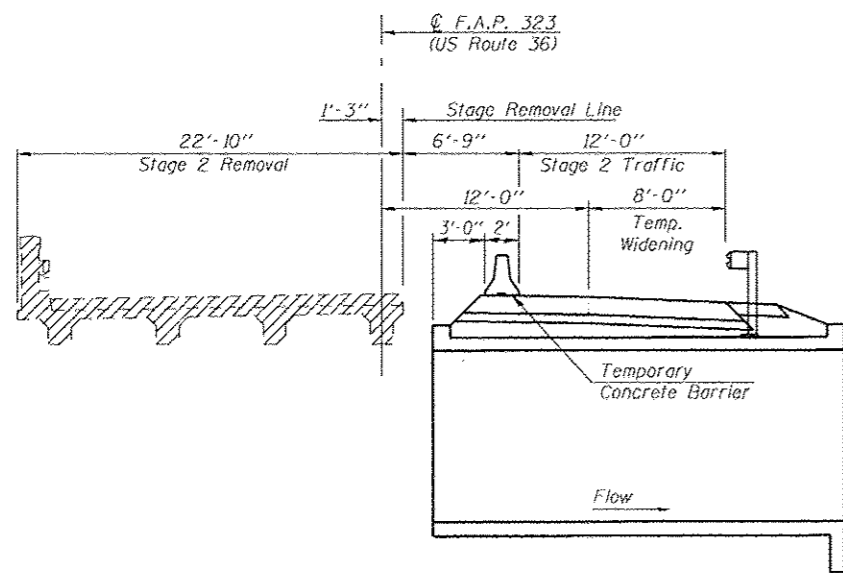

**STAGE 2 REMOVAL**  
(Looking East)

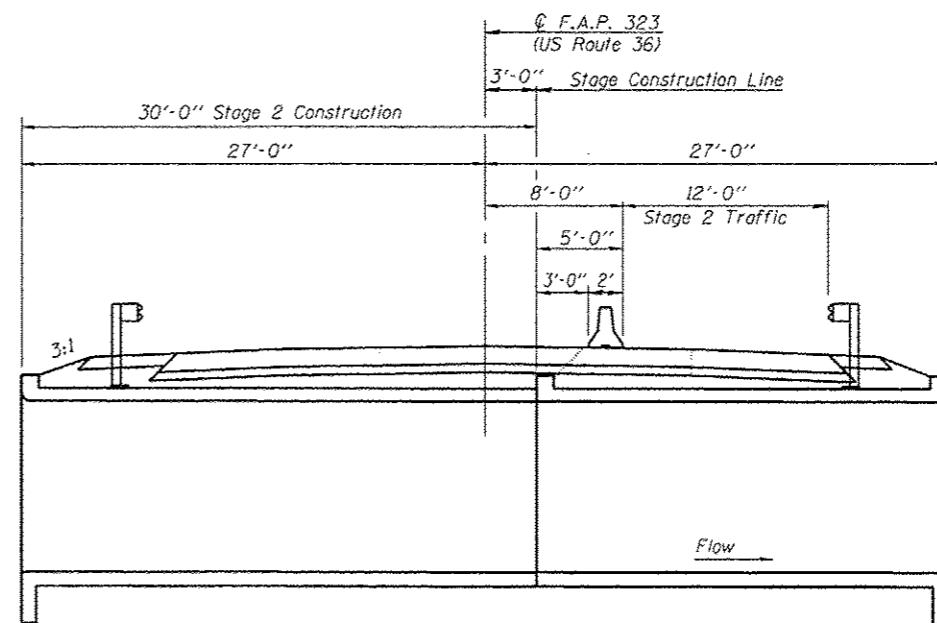

**STAGE 2 CONSTRUCTION**  
(Looking East)

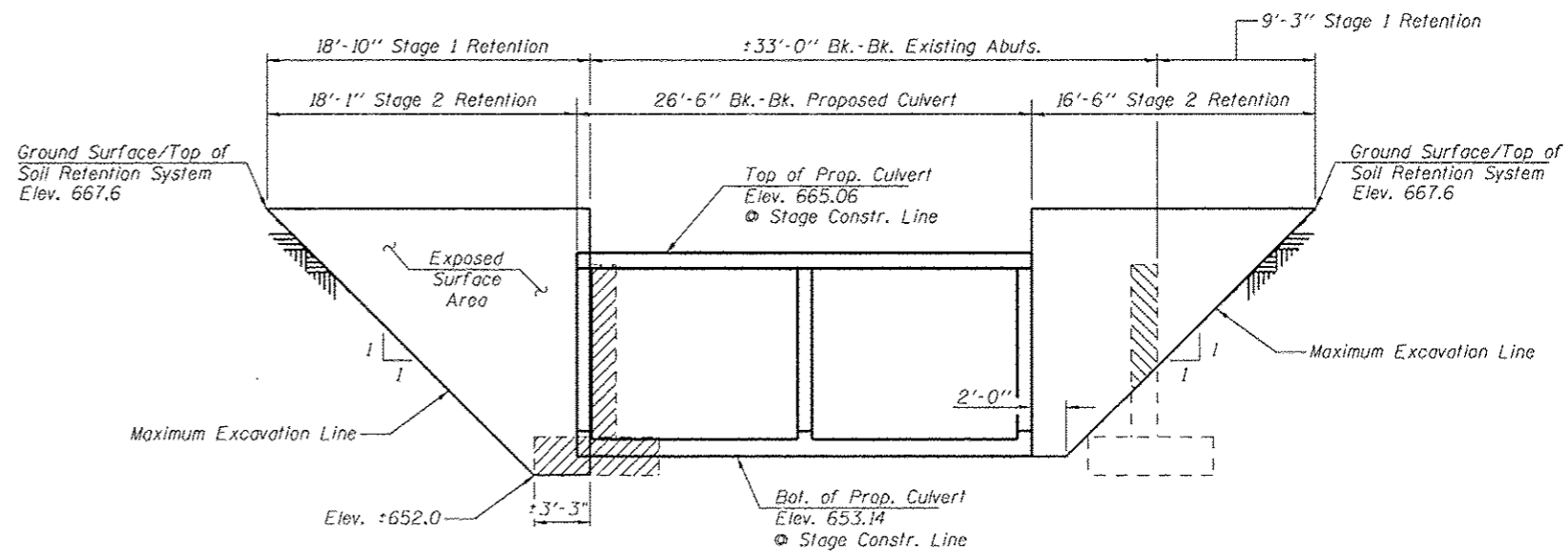

**TEMPORARY SOIL RETENTION SYSTEM**  
(Looking North)

**BILL OF MATERIAL**

ITEM	UNIT	QUANTITY
Temporary Soil Retention System	Sq. Ft.	307

**Notes:**

Hatched areas indicate Removal of Existing Structures. For details of Temporary Concrete Barrier, see sheet 5 of 7. See Roadway Plans for quantity of Temporary Concrete Barrier. A cantilevered sheet piling design does not appear feasible and additional members or other retention systems may be necessary. The Contractor shall submit a temporary soil retention system design including plan details and calculations for review and acceptance by the Engineer.

**STAGE CONSTRUCTION DETAILS & TEMPORARY SOIL RETENTION SYSTEM STRUCTURE NO. 070-2018**

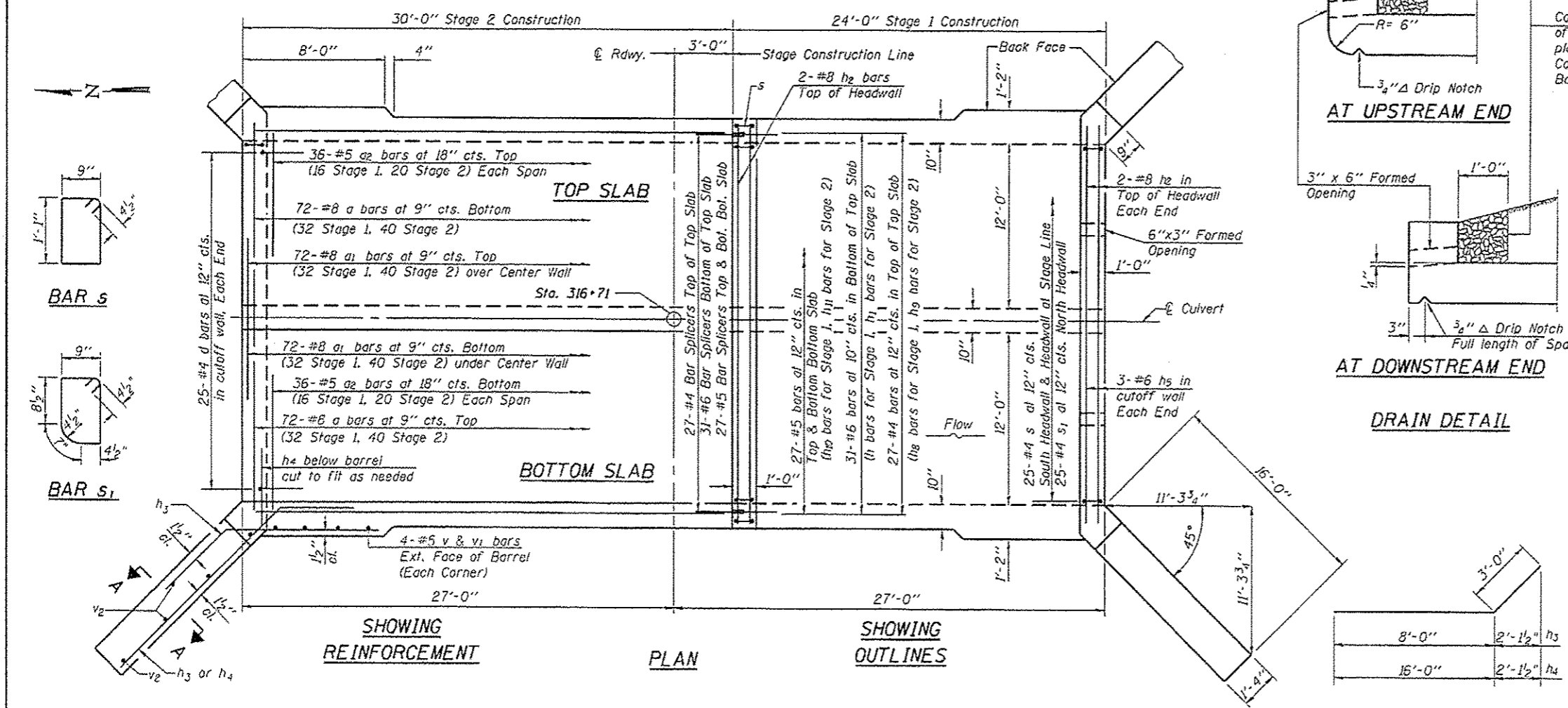
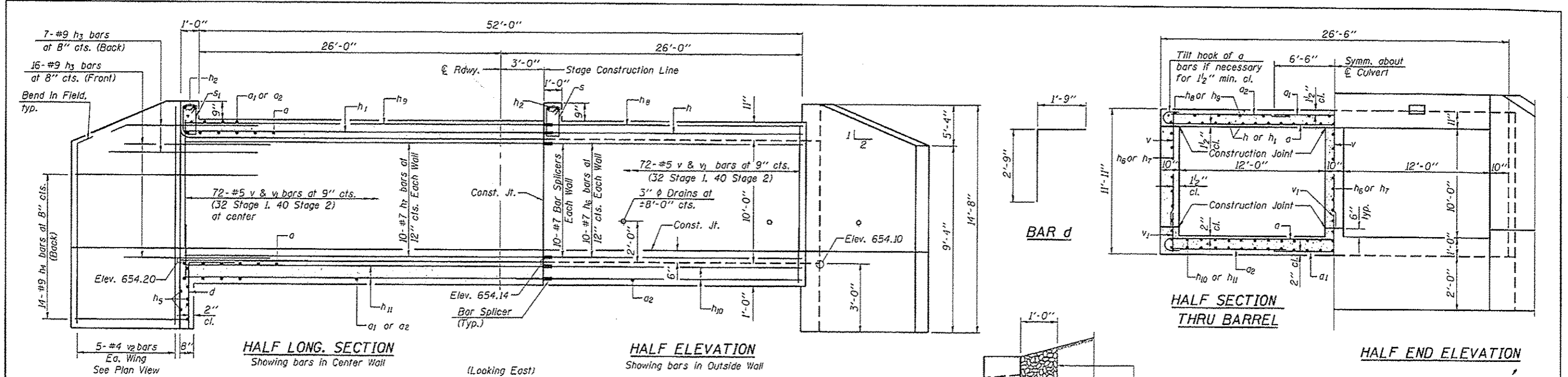

Coarse aggregate full length of both headwalls. To be placed by Grading Contractor. Cost included with Concrete Box Culverts.

**BILL OF MATERIAL**

Bar	No.	Size	Length	Shape
a	144	#8	28'-0"	⊔
a <sub>1</sub>	144	#8	13'-0"	—
a <sub>2</sub>	72	#5	8'-9"	—
d	50	#4	4'-6"	⊔
h	31	#6	23'-9"	—
h <sub>1</sub>	31	#6	29'-9"	—
h <sub>2</sub>	6	#8	26'-2"	—
h <sub>3</sub>	92	#9	11'-0"	—
h <sub>4</sub>	56	#9	19'-0"	—
h <sub>5</sub>	6	#6	26'-2"	—
h <sub>6</sub>	30	#7	23'-9"	—
h <sub>7</sub>	30	#7	29'-9"	—
h <sub>8</sub>	27	#4	23'-9"	—
h <sub>9</sub>	27	#4	29'-9"	—
h <sub>10</sub>	54	#5	23'-9"	—
h <sub>11</sub>	54	#5	29'-9"	—
v	232	#5	10'-3"	—
v <sub>1</sub>	232	#5	2'-8"	—
v <sub>2</sub>	20	#4	14'-5"	—
s	50	#4	4'-5"	⊔
s <sub>1</sub>	25	#4	4'-3"	⊔
Concrete Box Culverts			Cu. Yd.	198.5
Reinforcement Bars			Pound	37580

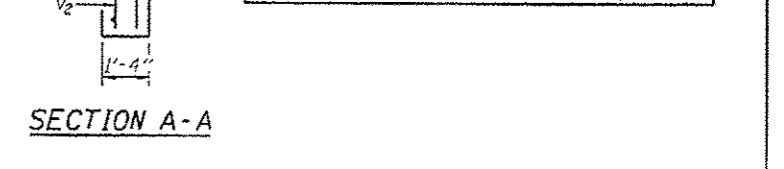

**CULVERT DETAILS**  
STRUCTURE NO. 070-2018

F.A.P. RTE.	SECTION	COUNTY	TOTAL SHEETS	SHEET NO.
323	1142BY1BR	MOULTRIE	35	26
CONTRACT NO. 74165				

FED. ROAD DIST. NO. 7 ILLINOIS FED. AID PROJECT

DB-H-0 10-1-08

**CEC** Cummins Engineering Corporation  
Civil and Structural Engineering

JOB = 2223.1	DESIGNED A.A.M. & T.S.H.
FILE = 0702018-74165-003-culvert.dgn	CHECKED M.D.C.
DATE = 8/11/2014	DRAWN T.S.H.
	CHECKED M.D.C.

Notes: A minimum distance of 8 feet of the barrel shall be poured monolithically with the wingwalls.

**BAR a**

Sheet 3 of 7

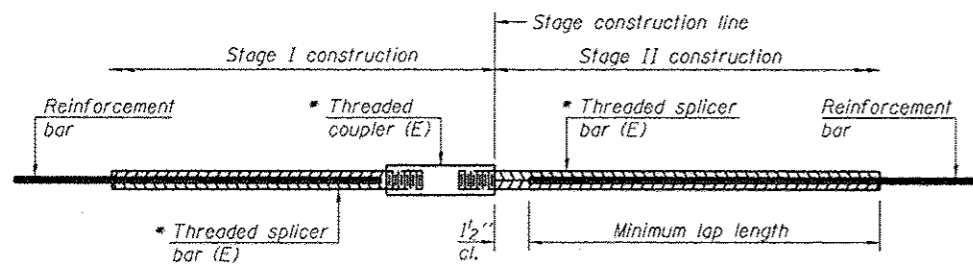

**STANDARD BAR SPLICER ASSEMBLY**

Bar size to be spliced	Minimum Lap Lengths					
	Table 1	Table 2	Table 3	Table 4	Table 5	Table 6
3, 4	1'-5"	1'-11"	2'-1"	2'-4"	2'-7"	2'-11"
5	1'-9"	2'-5"	2'-7"	2'-11"	3'-3"	3'-8"
6	2'-1"	2'-11"	3'-1"	3'-6"	3'-10"	4'-5"
7	2'-9"	3'-10"	4'-2"	4'-8"	5'-2"	5'-10"
8	3'-8"	5'-1"	5'-5"	6'-2"	6'-9"	7'-8"
9	4'-7"	6'-5"	6'-10"	7'-9"	8'-7"	9'-8"

- Table 1: Black bar, 0.8 Class C
- Table 2: Black bar, Top bar lap, 0.8 Class C
- Table 3: Epoxy bar, 0.8 Class C
- Table 4: Epoxy bar, Top bar lap, 0.8 Class C
- Table 5: Epoxy bar, Class C
- Table 6: Epoxy bar, Top bar top, Class C

Threaded splicer bar length = min. lap length + 1/2" + thread length

\* Epoxy not required on Bar Splicer Assembly components used in conjunction with black bars.

Location	Bar size	No. assemblies required	Table for minimum lap length
Top Slab	#4	27	Table 1
Top Slab	#6	31	Table 1
Bottom Slab	#5	54	Table 1
Barrel wall	#7	30	Table 2

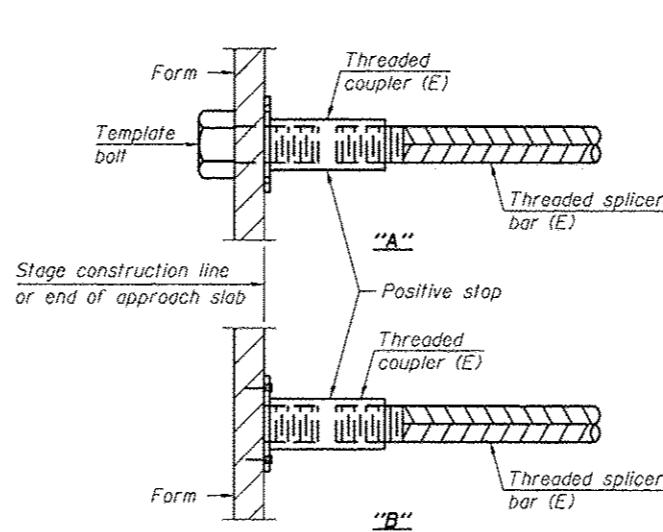

**INSTALLATION AND SETTING METHODS**

"A" : Set bar splicer assembly by means of a template bolt.  
 "B" : Set bar splicer assembly by nailing to wood forms or cementing to steel forms.  
 (E) : Indicates epoxy coating.

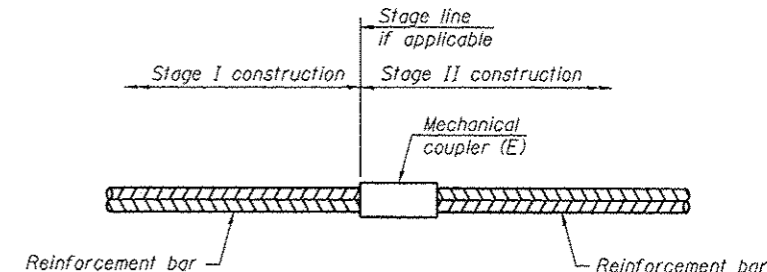

**STANDARD MECHANICAL SPLICER**

Location	Bar size	No. assemblies required

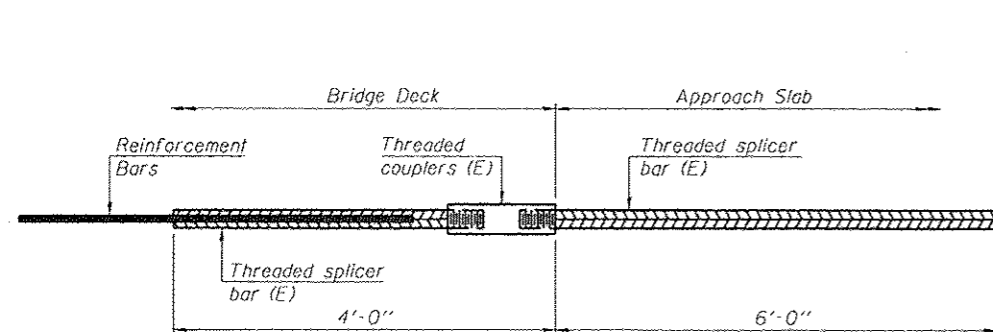

**BAR SPLICER ASSEMBLY FOR #5 BAR ON INTEGRAL OR SEMI-INTEGRAL ABUTMENTS**

No. required =

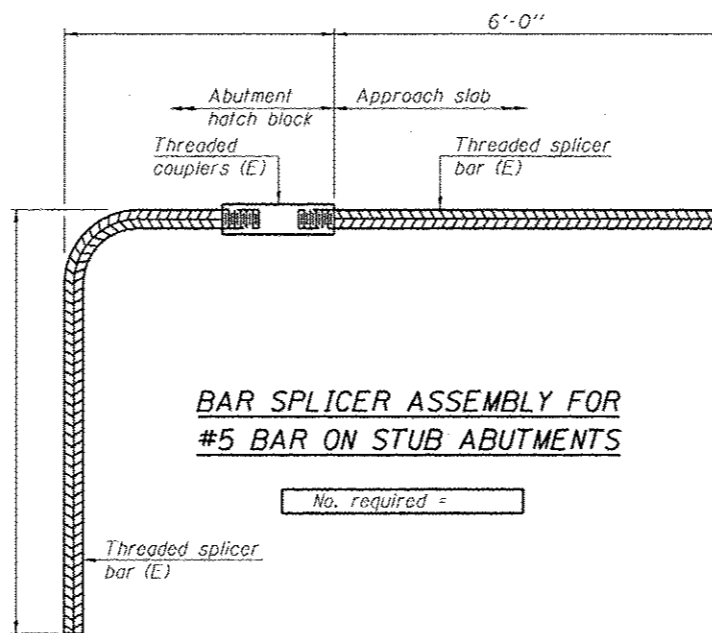

**BAR SPLICER ASSEMBLY FOR #5 BAR ON STUB ABUTMENTS**

No. required =

**NOTES**  
 Splicer bars shall be deformed with threaded ends and have a minimum 60 ksi yield strength.  
 All reinforcement shall be lapped and tied to the splicer bars.  
 Bar splicer assemblies shall be epoxy coated according to the requirements for reinforcement bars. See Section 508 of the Standard Specifications.  
 See approved list of bar splicer assemblies and mechanical splicers for alternatives.

**BAR SPLICER ASSEMBLY DETAILS  
 STRUCTURE NO. 070-2018**

BSD-1 1-27-12



JOB = 2223.1	DESIGNED A.A.M. & T.S.H.
FILE = 0702018-74165-004-barspl.dgn	CHECKED M.D.C.
DATE = 8/11/2014	DRAWN T.S.H.
	CHECKED M.D.C.

Sheet 4 of 7	F.A.P. RTE.	SECTION	COUNTY	TOTAL SHEETS	SHEET NO.
	323	(142BY)BR	MOULTRIE	35	27
CONTRACT NO. 74165					
FED. ROAD DIST. NO. 7 [ILLINOIS] FED. AID PROJECT					

When "A" is 3'-6" or less, the temporary concrete barrier shall be anchored to the new slab according to Detail I or Detail II. No anchorage is required when "A" is greater than 3'-6".

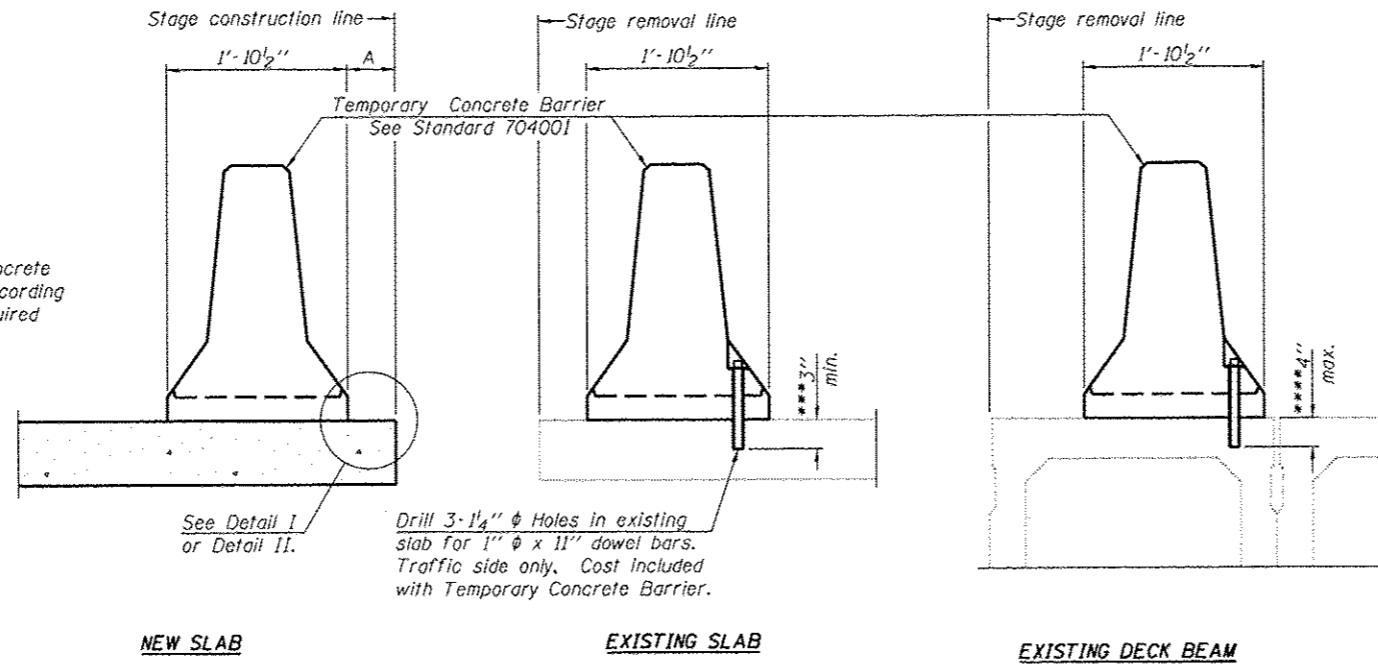

**SECTIONS THRU SLAB OR DECK BEAM**

**NOTES**

Detail I - With Bar Splicer or Couplers:  
Connect one (1) 1" x 7" x "W" steel  $\bar{L}$  to the top layer of couplers with 2-5/8"  $\phi$  bolts screwed to coupler at approximate  $\bar{C}$  of each barrier panel.

Detail II - With Extended Reinforcement Bars:  
Connect one (1) 1" x 7" x "W" steel  $\bar{L}$  to the concrete slab or concrete wearing surface with 2-5/8"  $\phi$  Expansion Anchors or cast in place inserts spaced between the top layer of reinforcement at approximate  $\bar{C}$  of each barrier panel.

Cost of anchorage is included with Temporary Concrete Barrier. The 1" x 7" x "W" plate shall not be removed until stage II construction forms and all reinforcement bars are in place and the concrete is ready to be placed.

\*\*\* Dimension shown is minimum required embedment into concrete. If hot-mix asphalt wearing surface is present, minimum embedment shall be in addition to wearing surface depth.

\*\*\*\* If existing deck beam is to remain in place after stage construction, embedment shall only be into wearing surface and not into existing deck beam concrete.

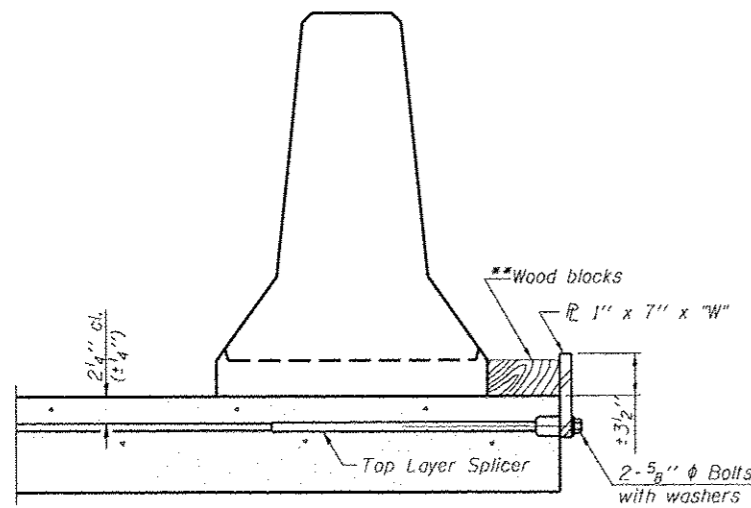

**DETAIL I**

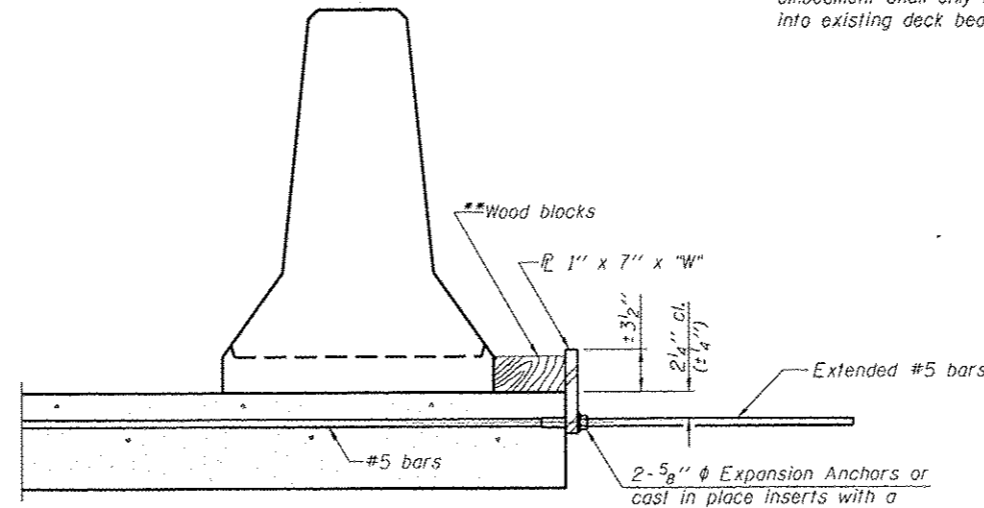

**DETAIL II**

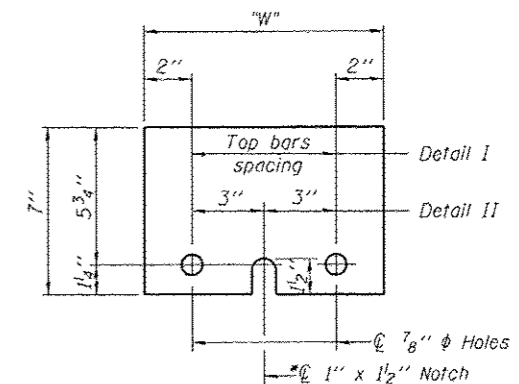

**STEEL RETAINER  $\bar{L}$  1" x 7" x "W"**

\* Required only with Detail II

\*\* Wood blocks may be omitted when required to provide minimum stage traffic lane width. When the wood blocks are omitted, the concrete barrier shall be in direct contact with the steel retainer plate.

"W" = Top bars spacing + 4"

**TEMPORARY CONCRETE BARRIER  
FOR STAGE CONSTRUCTION  
STRUCTURE NO. 070-2018**

R-27

7-1-10

**CEC** Cummins  
Engineering  
Corporation  
Civil and Structural Engineering

JOB = 2223.1	DESIGNED A.A.M. & T.S.H.
FILE = 0702018-74165-005-barrier.dgn	CHECKED M.D.C.
DATE = 8/11/2014	DRAWN T.S.H.
	CHECKED M.D.C.

Sheet 5 of 7	F.A.P. RTE. 323	SECTION (142BY)BR	COUNTY MOULTRIE	TOTAL SHEETS 35	SHEET NO. 28
	CONTRACT NO. 74165				
FED. ROAD DIST. NO. 7 ILLINOIS FED. AID PROJECT					



Illinois Department of Transportation  
Division of Highways  
Illinois Department of Transportation

### SOIL BORING LOG

Page 1 of 2  
Date 8/11/05

ROUTE FAP 323 (US 36) DESCRIPTION 2 Miles West of Hammond Over Drainage Ditch #4 LOGGED BY CNA  
SECTION (142BY)BR LOCATION NE, SEC. 3, TWP. 15N, RNG. 5E, PM  
COUNTY Moultrie DRILLING METHOD Hollow Stem Auger HAMMER TYPE Automatic

STRUCT. NO. Station	BORING NO. Station Offset Ground Surface Elev.	D (ft)	B (/6")	U (1sf)	M (%)	Soil Description								
						Surface Water Elev.	Stream Bed Elev.	Groundwater Elev.: First Encounter Upon Completion After Hrs.	Penetration H (ft)	Blow Count S (/6")	Soil Type U (1sf)	Moisture M (%)		
070-0009 316+75	1 Northeast Abut. 317+16 15.00ft Lt. 667.5					Dark Gray to Gray Sandy Clay Loam Till (continued)								
						Dark Gray/Black Mottled Silty Clay Loam (Embankment)								
						Dark Gray to Gray Sand Loam Till (Large Angular Gravel - Drilled Rough)								
						Dark Gray Sandy Clay Loam Till								
						Gray/Brown Mottled Sandy Clay Loam Till (Trace of Free Water)								
						Gray Sandy Clay Loam Till								
						(No Sample Obtained)								
						Dark Gray to Gray Sandy Clay Loam Till								
						Brown Dirty Very Coarse Sand & Gravel with Traces of Sandy Clay Loam Till (Drilled Rough)								
						Gray Sandy Clay Loam Till								
						Dark Brown Clay to Clay Loam								
						Brown Well Sorted Coarse Sand								

The Unconfined Compressive Strength (UCS) Failure Mode is indicated by (B-Bulge, S-Shear, P-Penetrometer)  
The SPT (N value) is the sum of the last two blow values in each sampling zone (AASHTO T206)  
BBS, from 137 (Rev. 8-99)



Illinois Department of Transportation  
Division of Highways  
Illinois Department of Transportation

### SOIL BORING LOG

Page 2 of 2  
Date 8/11/05

ROUTE FAP 323 (US 36) DESCRIPTION 2 Miles West of Hammond Over Drainage Ditch #4 LOGGED BY CNA  
SECTION (142BY)BR LOCATION NE, SEC. 3, TWP. 15N, RNG. 5E, PM  
COUNTY Moultrie DRILLING METHOD Hollow Stem Auger HAMMER TYPE Automatic

STRUCT. NO. Station	BORING NO. Station Offset Ground Surface Elev.	D (ft)	B (/6")	U (1sf)	M (%)	Soil Description								
						Surface Water Elev.	Stream Bed Elev.	Groundwater Elev.: First Encounter Upon Completion After Hrs.	Penetration H (ft)	Blow Count S (/6")	Soil Type U (1sf)	Moisture M (%)		
070-0009 316+75	1 Northeast Abut. 317+16 15.00ft Lt. 667.5					Brown Well Sorted Coarse Sand (continued)								
						Gray Sandy Clay Loam Till								
						(Pulled Augers/Re-drilled Hole - 6' of Blow In)								
						(Auger Refusal)								

The Unconfined Compressive Strength (UCS) Failure Mode is indicated by (B-Bulge, S-Shear, P-Penetrometer)  
The SPT (N value) is the sum of the last two blow values in each sampling zone (AASHTO T206)  
BBS, from 137 (Rev. 8-99)

### BORING LOGS STRUCTURE NO. 070-2018

<b>CEC</b> Cummins Engineering Corporation Civil and Structural Engineering	JOB = 2223.1	DESIGNED A.A.N. & T.S.H.
	FILE = 22231borings.dgn	CHECKED M.D.C.
	DATE = 4/29/2009	DRAWN T.S.H.
		CHECKED M.D.C.

Sheet 6 of 7	F.A.P. RTE. 323	SECTION (142BY)BR	COUNTY MOULTRIE	TOTAL SHEETS 35	SHEET NO. 29
	CONTRACT NO. 74165				
FED. ROAD DIST. NO. 7 ILLINOIS FED. AID PROJECT					



DATE	
BY	
FINAL SURVEY	
SURVEYED	
PLOTTED	
NOTE BOOK	
AREAS	
CHECKED	
NO.	

DATE	
BY	
ORIGINAL SURVEY	
SURVEYED	
PLOTTED	
NOTE BOOK	
AREAS	
CHECKED	
NO.	

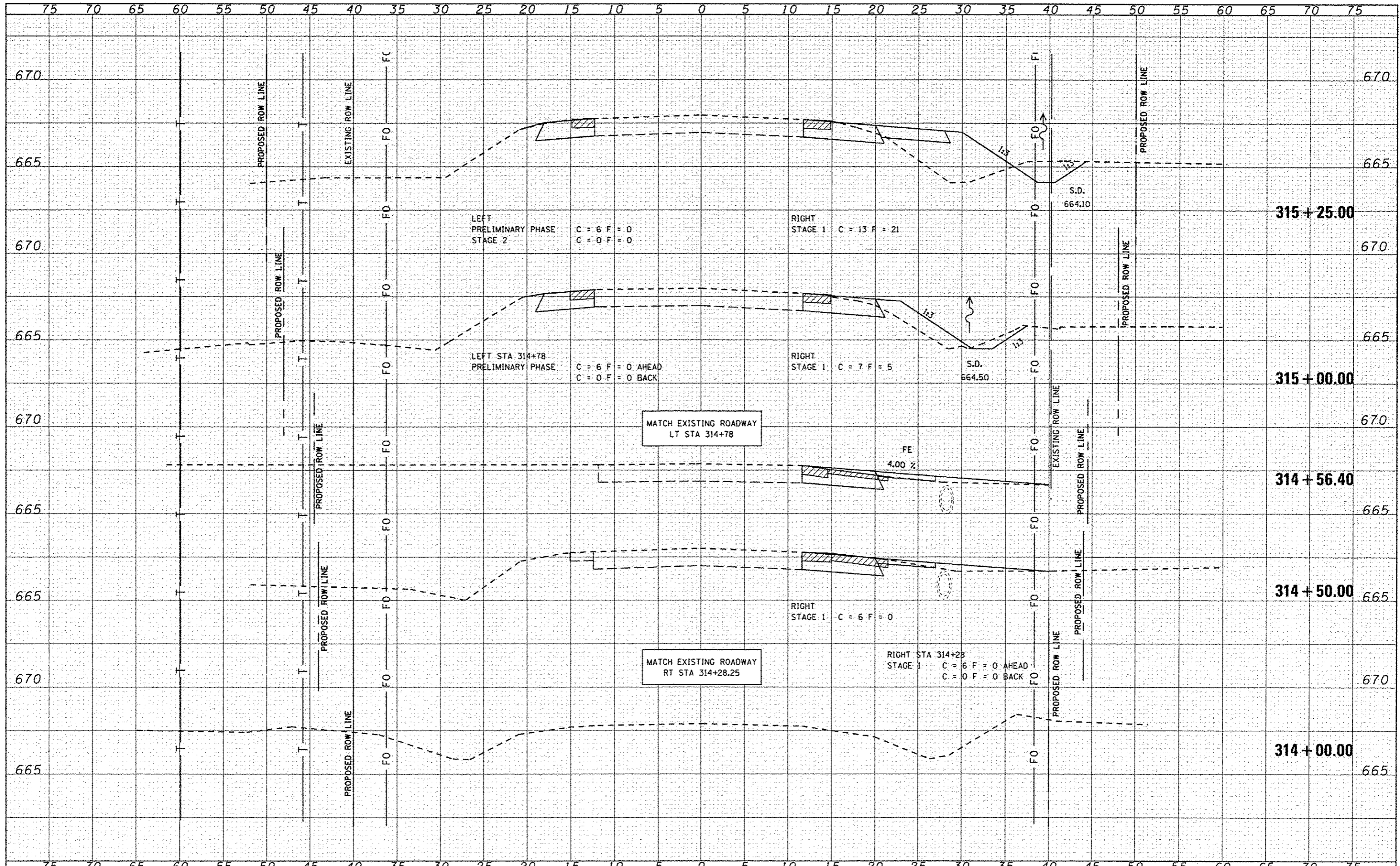

DATE	
BT	
NO.	
ORIGINAL SURVEY	
TEMPORARY	
NOTE BOOK	
AREAS CHECKED	

DATE	
BT	
NO.	
ORIGINAL SURVEY	
TEMPORARY	
NOTE BOOK	
AREAS CHECKED	

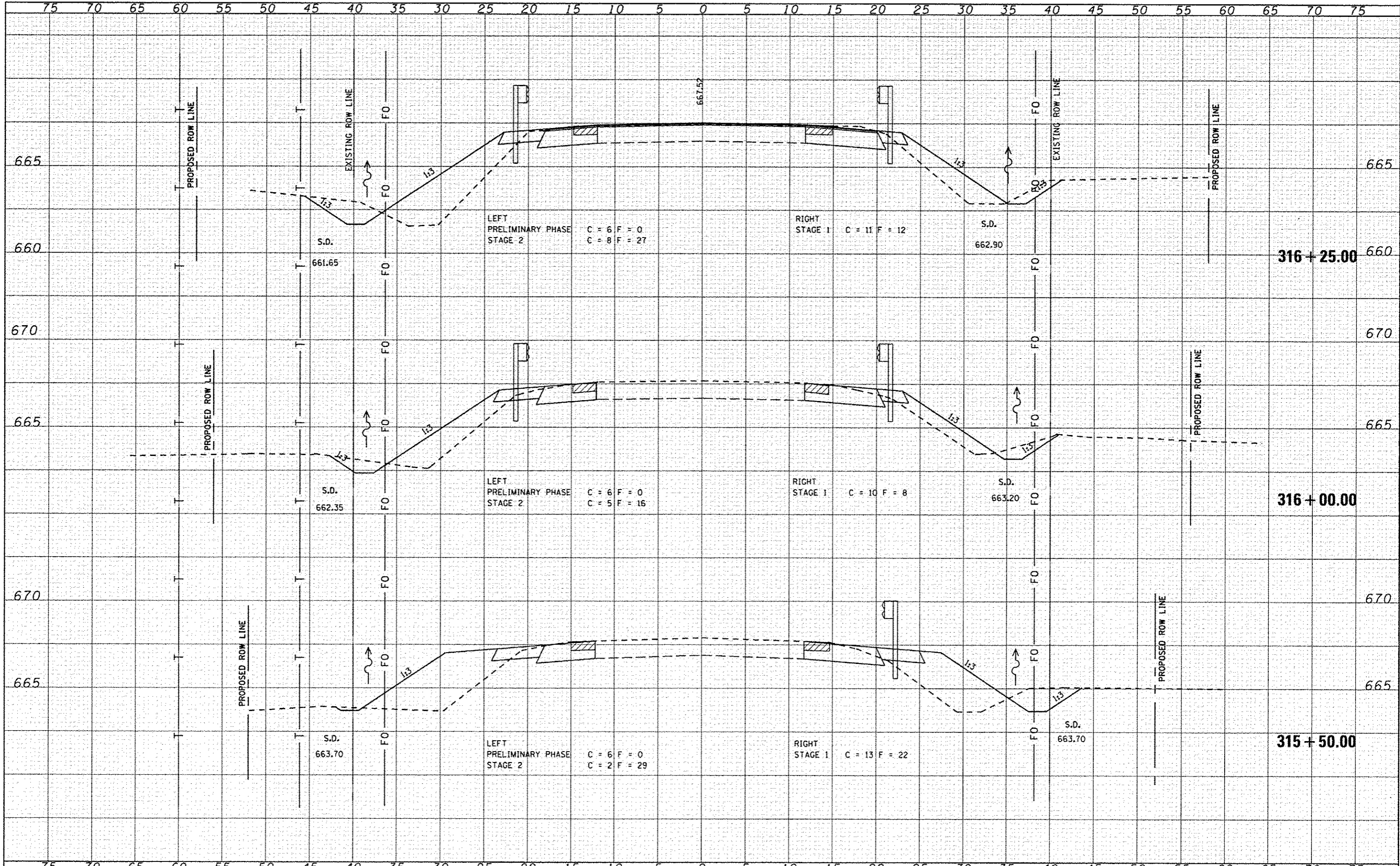

**CEC** Cummins  
Engineering  
Corporation  
Civil and Structural Engineering

JOB - 2223.1	DESIGNED - NAK	REVISED -
FILE NAME - 0774165-shs-us136a.dgn	DRAWN - AJH	REVISED -
PLOT SCALE - 1/8"=1'-0"	CHECKED - NAK	REVISED -
PLOT DATE - 8/11/2014	DATE - 7/12/2010	REVISED -

STATE OF ILLINOIS  
DEPARTMENT OF TRANSPORTATION

CROSS SECTIONS - US 136

F.A.P. RTE. 323	SECTION (142BY) BR	COUNTY MOULTRIE	TOTAL SHEETS 35	SHEET NO. 32
FED. ROAD DIST. NO.		ILLINOIS FED. AID PROJECT		

STA 315+50 TO STA 316+25

316 + 25.00

316 + 00.00

315 + 50.00



DATE	
BY	
ENR. SURVEYED	
SURVEY PLOTTED	
NOTE BOOK	
NO.	
AREAS CHECKED	

DATE	
BY	
ENR. SURVEYED	
SURVEY PLOTTED	
NOTE BOOK	
NO.	
AREAS CHECKED	

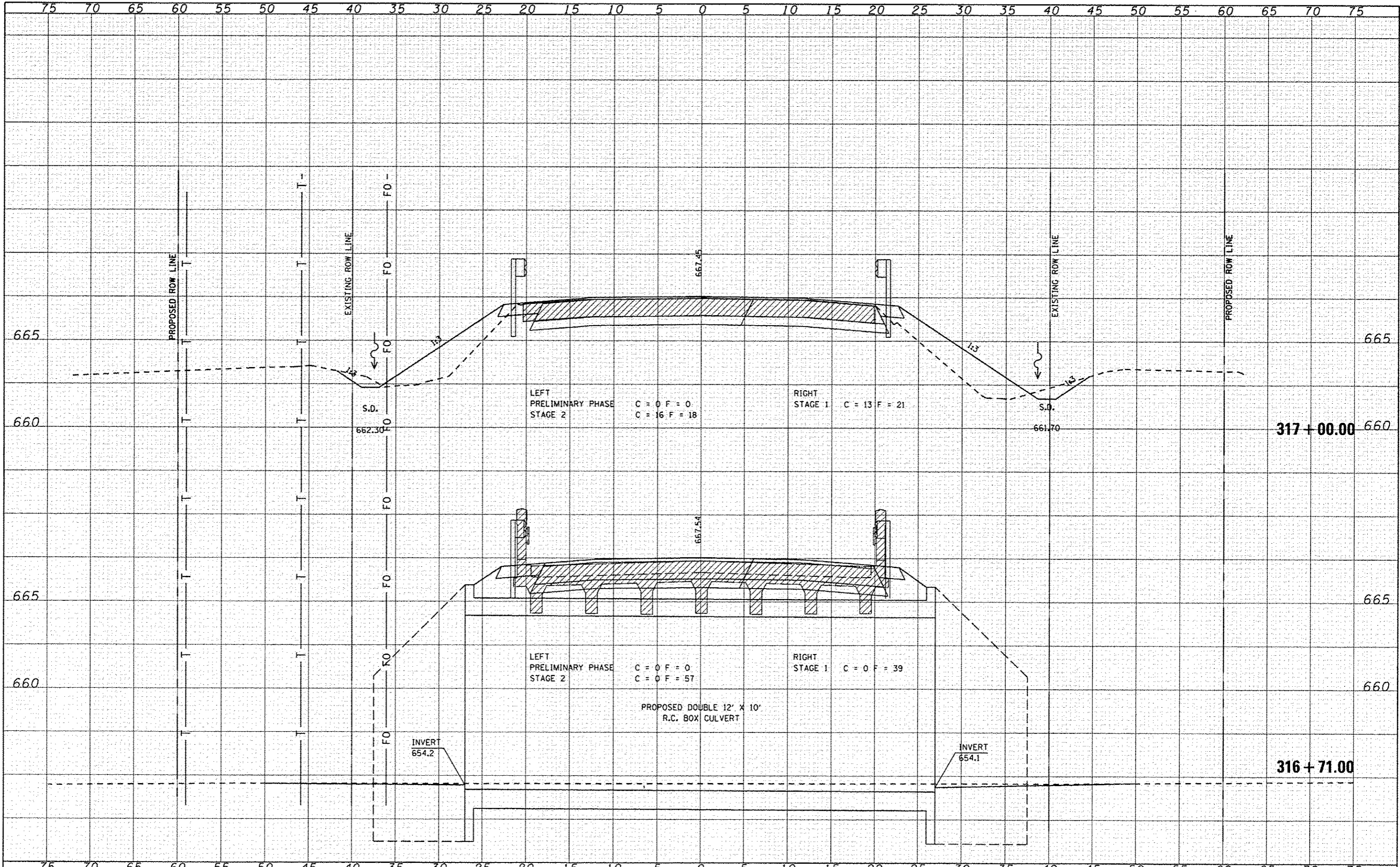

**CEC** Cummins Engineering Corporation  
Civil and Structural Engineering

JOB - 2223.1  
FILE NAME - D774165-sh1-us36ex.dgn  
PLOT SCALE - 1/8"=1'-0"  
PLOT DATE - 8/11/2014

DESIGNED - NAK	REVISED -
DRAWN - AJH	REVISED -
CHECKED - NAK	REVISED -
DATE - 7/12/2010	REVISED -

STATE OF ILLINOIS  
DEPARTMENT OF TRANSPORTATION

CROSS SECTIONS - US 36

STA 316+71 TO STA 317+00

F.A.P. RTE.	SECTION	COUNTY	TOTAL SHEETS	SHEET NO.
323	(142B) BR	MOULTRIE	35	33
FED. ROAD DIST. NO.		ILLINOIS FED. AID PROJECT		
		CONTRACT NO. 74165		

DATE	
BY	
DESIGNED	
DRAWN	
CHECKED	
DATE	

DATE	
BY	
DESIGNED	
DRAWN	
CHECKED	
DATE	

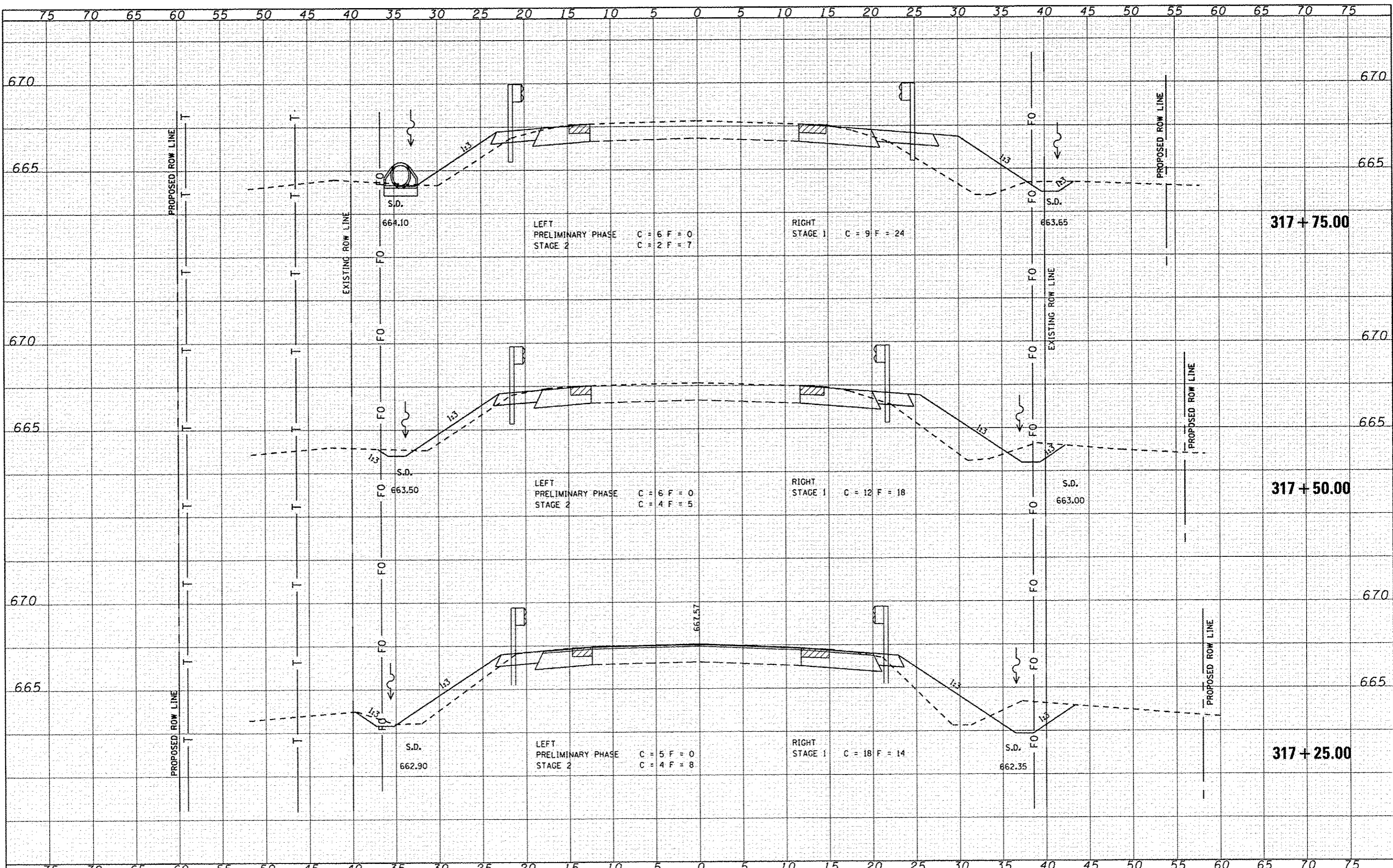

DATE	
BY	
FINAL SURVEY	
SCHEMATIC	
NOTE BOOK	
AREAS CHECKED	

DATE	
BY	
ORIGINAL SURVEY	
SCHEMATIC	
NOTE BOOK	
AREAS CHECKED	

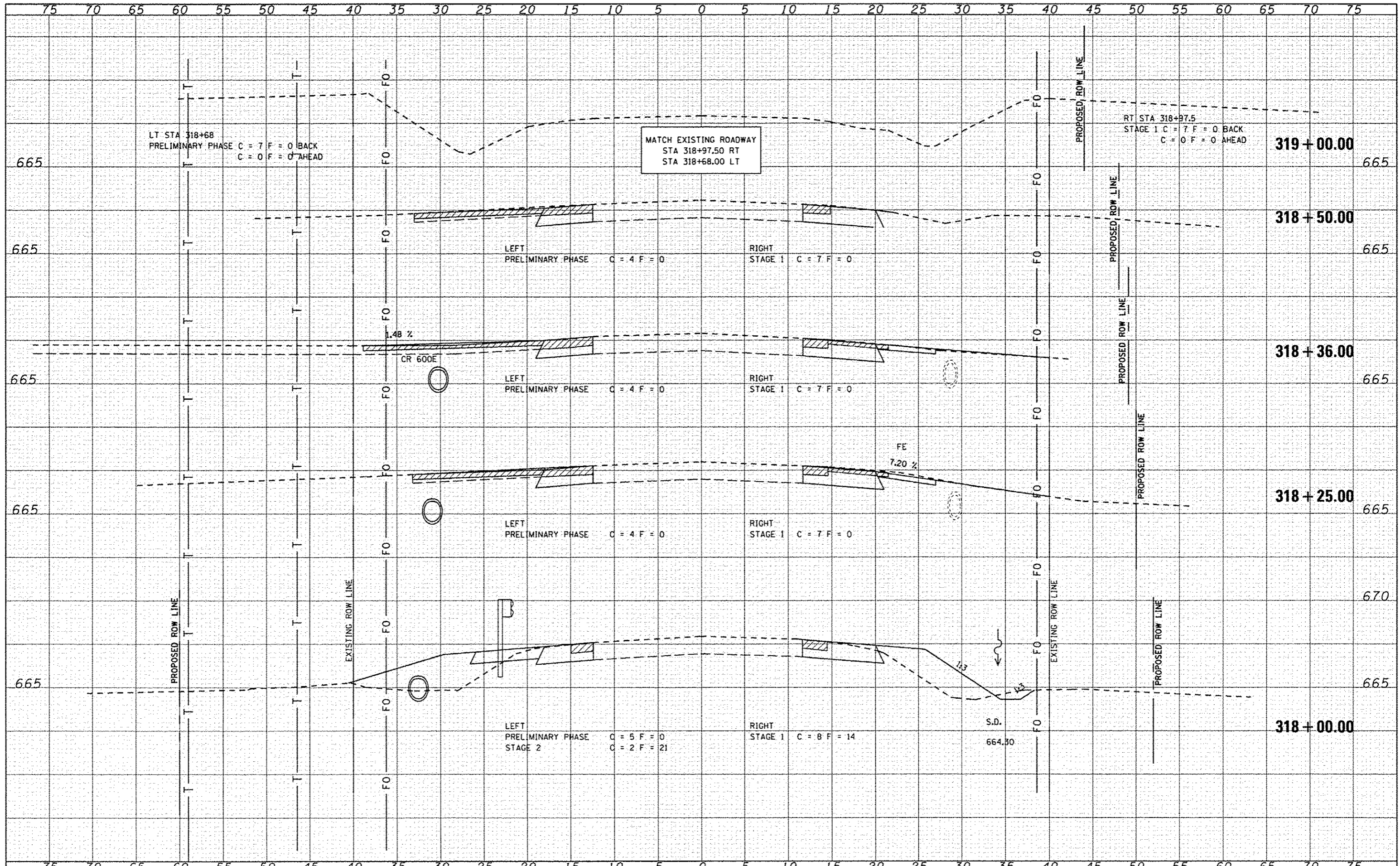

**CEC** Cummins Engineering Corporation  
Civil and Structural Engineering

JOB # 2223.1  
FILE NAME = 0774165-shs-us36ws.dgn  
PLOT SCALE = 1/8"=1'-0"  
PLOT DATE = 8/11/2014

DESIGNED - NAK  
DRAWN - AJH  
CHECKED - NAK  
DATE - 7/12/2010

REVISED -  
REVISED -  
REVISED -  
REVISED -

**STATE OF ILLINOIS  
DEPARTMENT OF TRANSPORTATION**

**CROSS SECTIONS - US 36**

STA 318+00 TO STA 319+00

F.A.P. RTE.	SECTION	COUNTY	TOTAL SHEETS	SHEET NO.
323	(142BY) BR	MOULTRIE	35	35
FED. ROAD DIST. NO.			ILLINOIS FED. AID PROJECT	
			CONTRACT NO. 74165	