

STATE OF ILLINOIS  
DEPARTMENT OF TRANSPORTATION  
DIVISION OF HIGHWAYS

**PROPOSED  
HIGHWAY PLANS**

F.A.I. ROUTE 57 (I-57)  
SECTION D7 BRIDGE REPAIRS 2015-3

BRIDGE REPAIR  
CUMBERLAND COUNTY

C-97-012-14

FOR INDEX OF SHEETS, SEE SHEET NO. 2

ADT = 17,600 (2013)

PROJECT LOCATION:  
STRUCTURE #018-0005 &  
STRUCTURE #018-0006

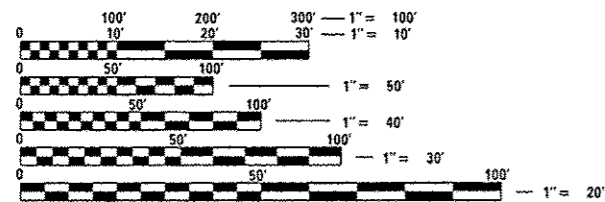

FULL SIZE PLANS HAVE BEEN PREPARED USING STANDARD ENGINEERING SCALES. REDUCED SIZED PLANS WILL NOT CONFORM TO STANDARD SCALES. IN MAKING MEASUREMENTS ON REDUCED PLANS, THE ABOVE SCALES MAY BE USED.

J.U.L.I.E.  
JOINT UTILITY LOCATION INFORMATION FOR EXCAVATION  
1-800-892-0123  
OR 811

PROJECT ENGINEER: TOM RONAN  
PROJECT MANAGER: KALEB HIRTZEL  
PHONE: (217)-342-8320  
CONTRACT NO. 74647

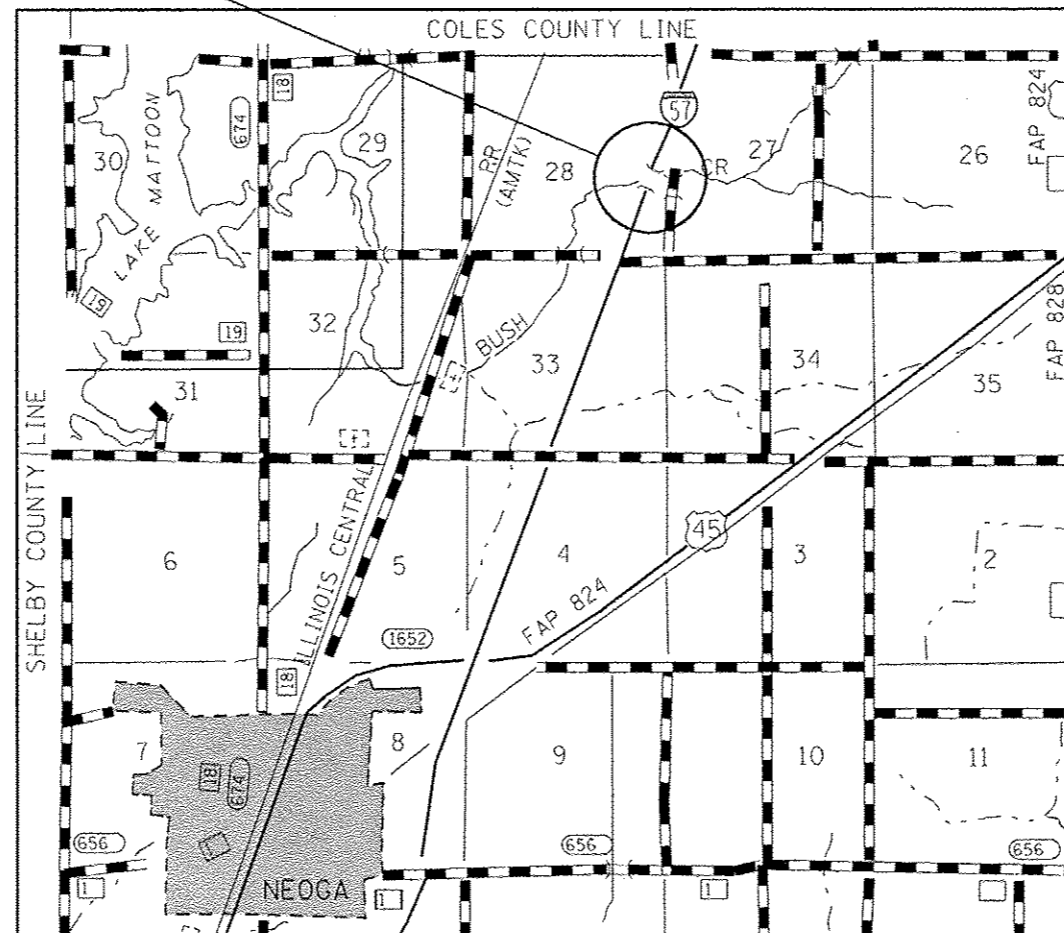

GROSS LENGTH = 598 FT. = 0.11 MILE  
NET LENGTH = 598 FT. = 0.11 MILE

F.A.I. RTE.	SECTION	COUNTY	TOTAL SHEETS	SHEET NO.
57		CUMBERLAND	30	1
		ILLINOIS	CONTRACT NO. 74647	

• D7 Bridge Repairs 2015-3

D-97-006-14

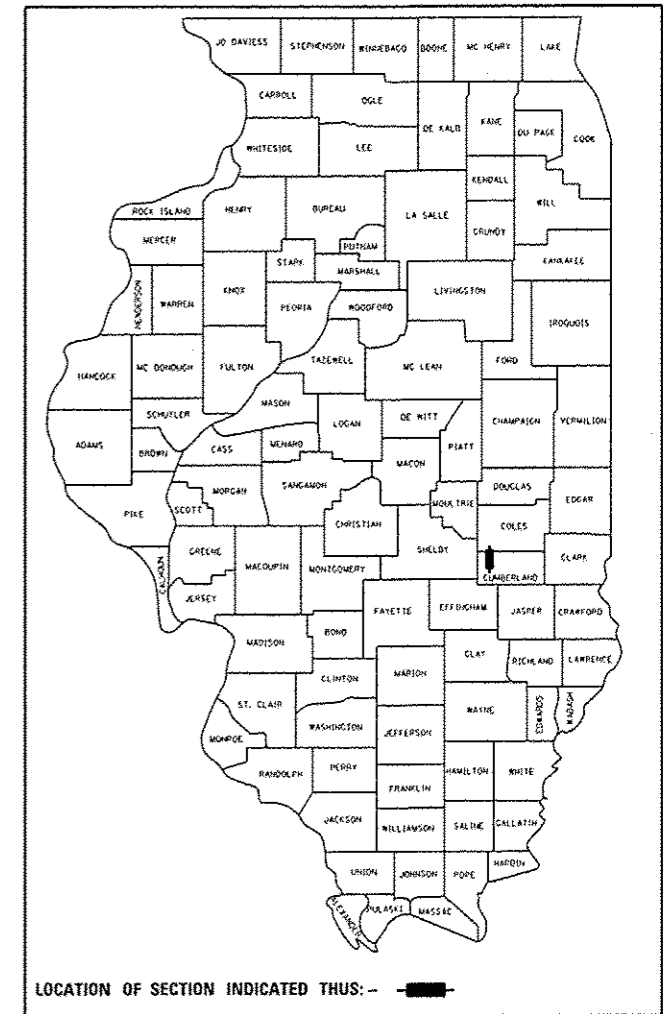

LOCATION OF SECTION INDICATED THUS: - [black rectangle] -

STATE OF ILLINOIS  
DEPARTMENT OF TRANSPORTATION  
DIVISION OF HIGHWAYS

SUBMITTED SEPTEMBER 29, 2014  
*Roger L. Dishell*  
DEPUTY DIRECTOR OF HIGHWAYS, REGION ENGINEER

*John D. Baranzelli*  
ENGINEER OF DESIGN AND ENVIRONMENT

*Jan 30, 2015*  
*Omer Osman*  
DIRECTOR OF HIGHWAYS, CHIEF ENGINEER

PRINTED BY THE AUTHORITY  
OF THE STATE OF ILLINOIS



100% STATE

100% STATE

SUMMARY OF QUANTITIES			TOTAL QUANTITIES	CONSTRUCTION TYPE CODE		
CODE NO	ITEM	UNIT		0014		
31101000	SUBBASE GRANULAR MATERIAL, TYPE B	TON	106	106		
35400500	PORTLAND CEMENT CONCRETE BASE COURSE WIDENING 10"	SO YD	932	932		
42001200	PAVEMENT FABRIC	SO YD	932	932		
44004250	PAVED SHOULDER REMOVAL	SO YD	932	932		
50102400	CONCRETE REMOVAL	CU YD	40	40		
50300255	CONCRETE SUPERSTRUCTURE	CU YD	40	40		
50300260	BRIDGE DECK GROOVING	SO YD	978	978		
50300300	PROTECTIVE COAT	SO YD	98	98		
50500405	FURNISHING AND ERECTING STRUCTURAL STEEL	POUND	3960	3960		
50800205	REINFORCEMENT BARS, EPOXY COATED	POUND	4920	4920		
50800515	BAR SPLICERS	EACH	60	60		
52000110	PREFORMED JOINT STRIP SEAL	FOOT	208	208		
52100010	ELASTOMERIC BEARING ASSEMBLY, TYPE I	EACH	14	14		

SUMMARY OF QUANTITIES			TOTAL QUANTITIES	CONSTRUCTION TYPE CODE		
CODE NO	ITEM	UNIT		0014		
52100020	ELASTOMERIC BEARING ASSEMBLY, TYPE II	EACH	14	14		
52100520	ANCHOR BOLTS, 1"	EACH	56	56		
64200116	SHOULDER RUMBLE STRIPS, 16 INCH	FOOT	1635	1635		
67000500	ENGINEER'S FIELD OFFICE, TYPE B	CAL MO	4	4		
67100100	MOBILIZATION	L SUM	1	1		
70100207	TRAFFIC CONTROL AND PROTECTION, STANDARD 701402	EACH	2	2		
70100800	TRAFFIC CONTROL AND PROTECTION, STANDARD 701401	L SUM	1	1		
70103815	TRAFFIC CONTROL SURVEILLANCE	CAL DA	5	5		
70300100	SHORT TERM PAVEMENT MARKING	FOOT	40	40		
70301000	WORK ZONE PAVEMENT MARKING REMOVAL	SQ FT	703	703		
70400100	TEMPORARY CONCRETE BARRIER	FOOT	675	675		
70400200	RELOCATE TEMPORARY CONCRETE BARRIER	FOOT	675	675		

13

• 07 Bridge Repairs 2015-3

FILE NAME :	USER NAME : kstffanik	DESIGNED -	REVISED -
\\pwwork\pwwork\dot\kstffanik\2015\07\74647\shl-soa.dgn		DRAWN -	REVISED -
		CHECKED -	REVISED -
		DATE -	REVISED -

STATE OF ILLINOIS  
DEPARTMENT OF TRANSPORTATION

SUMMARY OF QUANTITIES

SCALE: N/A SHEET 1 OF 2 SHEETS STA. TO STA.

F.A.I. RTE.	SECTION	COUNTY	TOTAL SHEETS	SHEET NO.
57	*	CUMBERLAND	30	3
CONTRACT NO. 74647			ILLINOIS FED. AID PROJECT	

100% STATE

100% STATE

SUMMARY OF QUANTITIES			TOTAL QUANTITIES	CONSTRUCTION TYPE CODE		
CODE NO	ITEM	UNIT		0014		
70600250	IMPACT ATTENUATORS, TEMPORARY (NON-REDIRECTIVE), TEST LEVEL 3	EACH	2	2		
70600350	IMPACT ATTENUATORS, RELOCATE (NON-REDIRECTIVE), TEST LEVEL 3	EACH	2	2		
* 78003110	PREFORMED PLASTIC PAVEMENT MARKING, TYPE B - LINE 4"	FOOT	2116	2116		
* 78003130	PREFORMED PLASTIC PAVEMENT MARKING, TYPE B - LINE 6"	FOOT	60	60		
* 78100105	RAISED REFLECTIVE PAVEMENT MARKER (BRIDGE)	EACH	8	8		
X7010410	SPEED DISPLAY TRAILER	CAL MO	8	8		
X7015005	CHANGEABLE MESSAGE SIGN	CAL DA	28	28		
* X7830070	GROOVING FOR RECESSED PAVEMENT MARKING 5"	FOOT	2116	2116		
* X7830074	GROOVING FOR RECESSED PAVEMENT MARKING 7"	FOOT	60	60		
Z0001899	JACK AND REMOVE EXISTING BEARINGS	EACH	28	28		
Z0004556	HOT-MIX ASPHALT SURFACE REMOVAL (DECK)	SO YD	962	962		

SUMMARY OF QUANTITIES			TOTAL QUANTITIES	CONSTRUCTION TYPE CODE		
CODE NO	ITEM	UNIT		0014		
Z0012111	BRIDGE DECK FLY ASH OR GGBF SLAG CONCRETE OVERLAY, 2 1/2"	SO YD	962	962		
Z0012130	BRIDGE DECK SCARIFICATION 3/4"	SO YD	962	962		
Z0012754	STRUCTURAL REPAIR OF CONCRETE (DEPTH EQUAL TO OR LESS THAN 5 INCHES)	SO FT	21	21		
Z0015802	PLUG EXISTING DECK DRAINS	EACH	52	52		
Z0016001	DECK SLAB REPAIR (FULL DEPTH, TYPE I)	SO YD	1	1		
Z0016002	DECK SLAB REPAIR (FULL DEPTH, TYPE II)	SO YD	104	104		
<del>70107007</del>	PAVEMENT MARKING BLACKOUT TAPE, 7"	FOOT	1183	1183		

\* SPECIALTY ITEM

\* D7 Bridge Repairs 2015-3

FILE NAME =	USER NAME = steffannk	DESIGNED -	REVISED -
ca:\p_w\work\avidot\steffannk\0368705\0374647-ahh-soq.dgn		DRAWN -	REVISED -
		CHECKED -	REVISED -
		DATE -	REVISED -

STATE OF ILLINOIS  
DEPARTMENT OF TRANSPORTATION

SUMMARY OF QUANTITIES

SCALE: N/A SHEET 2 OF 2 SHEETS STA. TO STA.

F.A.I. RTE.	SECTION	COUNTY	TOTAL SHEETS	SHEET NO.
57	*	CUMBERLAND	30	4
			CONTRACT NO. 74647	
ILLINOIS FED. AID PROJECT				

# EXISTING TYPICAL CROSS SECTION

STA. 248+10 TO STA. 253+91 (NB)  
 STA. 248+27 TO STA. 254+08 (SB)

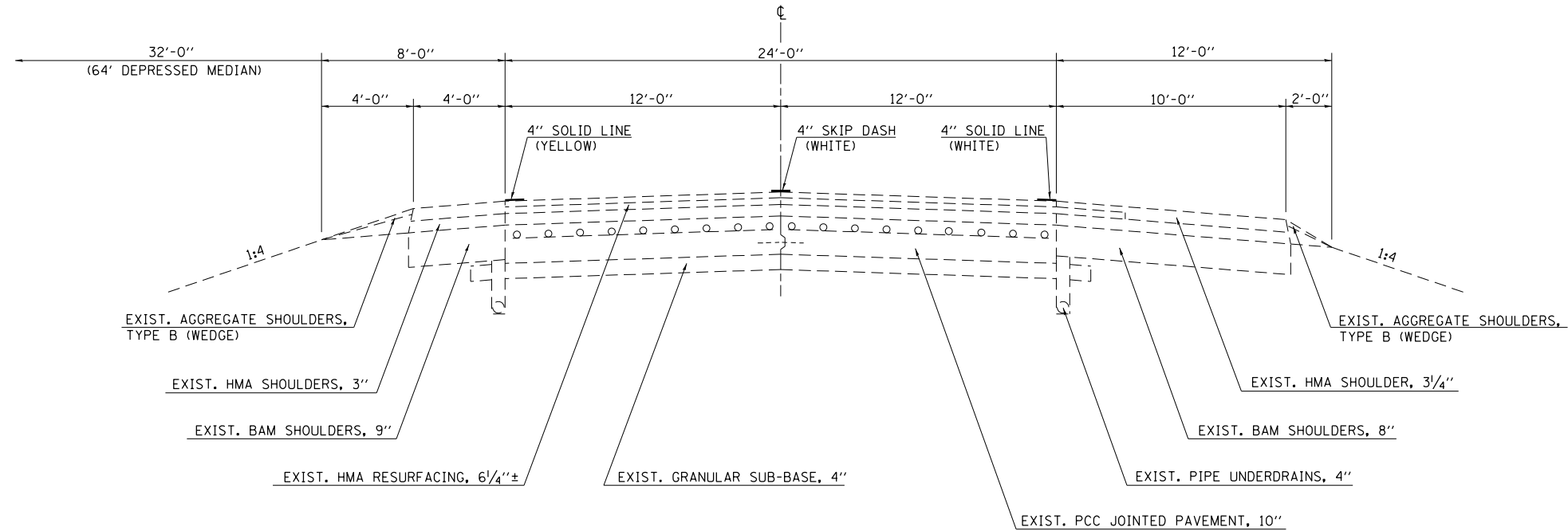

NOTE: NOT TO SCALE

# PROPOSED TYPICAL CROSS SECTION

STA. 248+10 TO STA. 253+91 (NB)  
 STA. 248+27 TO STA. 254+08 (SB)

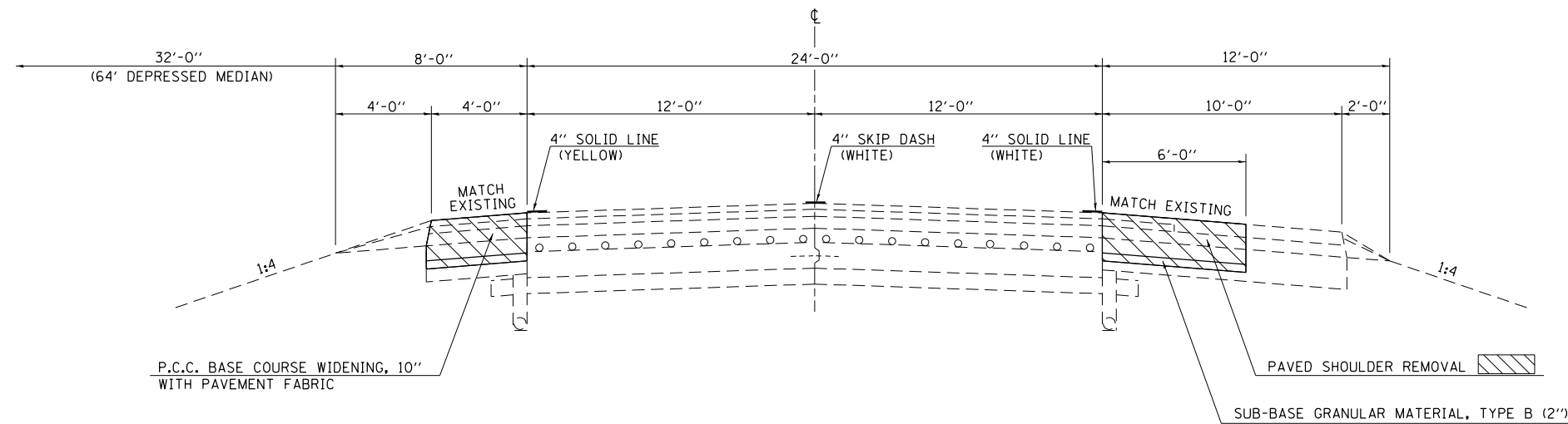

NOTE: NOT TO SCALE

FILE NAME =	USER NAME = steffenmk	DESIGNED -	REVISED -
c:\pwork\pwork\stevfennk\d0368705\074647-sht-typicals.dgn		DRAWN -	REVISED -
	PLOT SCALE = 100.0000' / 1in.	CHECKED -	REVISED -
Default	PLOT DATE = 10/27/2014	DATE -	REVISED -

STATE OF ILLINOIS  
 DEPARTMENT OF TRANSPORTATION

TYPICAL CROSS SECTIONS

SCALE: N/A SHEET 1 OF 1 SHEETS STA. TO STA.

* 07 Bridge Repairs 2015-3				
F.A.I. RTE.	SECTION	COUNTY	TOTAL SHEETS	SHEET NO.
57	*	CUMBERLAND	30	5
CONTRACT NO. 74647				
ILLINOIS FED. AID PROJECT				

WIDENING SCHEDULE

STATION TO STATION			SUBBASE GRANULAR MATERIAL, TYPE B	PORTLAND CEMENT CONCRETE BASE COURSE WIDENING, 10"	PAVEMENT FABRIC	PAVED SHOULDER REMOVAL	SHOULDER RUMBLE STRIPS
			TON	SQ YD	SO YD	SO YD	FOOT
NB							
248+10	TO	250+66	19.4	170.7	170.7	170.7	256.0
251+86	TO	253+91	15.6	136.7	136.7	136.7	205.0
248+63	TO	250+83	11.1	97.8	97.8	97.8	220.0
252+03	TO	253+40	6.9	60.9	60.9	60.9	137.0
SB							
248+27	TO	250+15	14.3	125.3	125.3	125.3	188.0
251+35	TO	254+08	20.7	182.0	182.0	182.0	273.0
248+79	TO	250+31	7.7	67.6	67.6	67.6	152.0
251+52	TO	253+56	10.3	90.7	90.7	90.7	204.0
TOTALS			106	932	932	932	1635

TRAFFIC CONTROL DEVICES

STATION TO STATION			TEMPORARY CONCRETE BARRIER	RELOCATE TEMPORARY CONCRETE BARRIER	IMPACT ATTENUATORS, TEMPORARY (NON-REDIRECTIVE), TEST LEVEL 3	IMPACT ATTENUATORS, RELOCATE (NON-REDIRECTIVE), TEST LEVEL 3
			FOOT	FOOT	EACH	EACH
STAGE I						
NB						
248+76	TO	250+38	162.5	0.0	1	-
250+38	TO	252+13	175.0	0.0	-	-
SB						
250+05	TO	251+80	175.0	0.0	-	-
251+08	TO	253+42	162.5	0.0	1	-
STAGE II						
NB						
248+77	TO	250+39	0.0	162.5	-	1
250+39	TO	252+14	0.0	175.0	-	-
SB						
250+05	TO	251+80	0.0	175.0	-	-
251+80	TO	253+42	0.0	162.5	-	1
TOTALS			675	675	2	2

FILE NAME =	USER NAME = steffenmk	DESIGNED -	REVISED -
ct:\pw\work\p\dot\steffenmk\d0368705\074647-sht-sch.dgn		DRAWN -	REVISED -
Default	PLOT SCALE = 100.0000' / 1in.	CHECKED -	REVISED -
	PLOT DATE = 10/27/2014	DATE -	REVISED -

STATE OF ILLINOIS  
DEPARTMENT OF TRANSPORTATION

SCHEDULE OF QUANTITIES			
SCALE: N/A	SHEET 1 OF 2 SHEETS	STA.	TO STA.

• D7 Bridge Repairs 2015-3				
F.A.I. RTE.	SECTION	COUNTY	TOTAL SHEETS	SHEET NO.
57	•	CUMBERLAND	30	6
CONTRACT NO. 74647				
ILLINOIS FED. AID PROJECT				

PAVEMENT MARKING SCHEDULE

STATION	TO	STATION	PAVEMENT MARKING BLACKOUT TAPE, 7"	SHORT TERM PAVEMENT MARKING	WORK ZONE PAVEMENT MARKING REMOVAL	GROOVING FOR RECESSED PAVEMENT MARKING 5"	PREFORMED PLASTIC PAVEMENT MARKING, TYPE B, 4"	GROOVING FOR RECESSED PAVEMENT MARKING 7"	PREFORMED PLASTIC PAVEMENT MARKING, TYPE B, 6"	RAISED REFLECTIVE PAVEMENT MARKER ( BRIDGE)
			FOOT	FOOT	SO FT	FOOT	SO FT	FOOT	FOOT	EACH
NB										
233+35	TO	248+10	368.8	-	215.1	-	-	-	-	-
248+10	TO	250+38	57.0	8.0	35.9	403.0	403.0	-	-	-
250+38	TO	250+83	2.0	4.0	2.5	90.0	90.0	-	-	-
250+83	TO	252+03	119.0	-	69.4	240.0	240.0	30.0	30.0	4
252+03	TO	252+13	-	-	-	20.0	20.0	-	-	-
252+13	TO	253+91	44.5	8.0	28.6	305.0	305.0	-	-	-
SB										
248+27	TO	250+05	44.5	8.0	28.6	304.0	304.0	-	-	-
250+05	TO	250+31	15.0	-	8.8	52.0	52.0	-	-	-
250+31	TO	251+52	106.0	-	61.8	242.0	242.0	30.3	30.3	4
251+52	TO	251+80	-	4.0	1.3	56.0	56.0	-	-	-
251+80	TO	254+08	57.0	8.0	35.9	404.0	404.0	-	-	-
254+08	TO	268+83	368.8	-	215.1	-	-	-	-	-
TOTALS			1183	40	703	2116	2116	60	60	8

FILE NAME =	USER NAME = steffenmk	DESIGNED -	REVISED -
ci:\pw\work\p\dot\steffenmk\d0368705\074647-sht-sch.dgn		DRAWN -	REVISED -
Default	PLOT SCALE = 100.0000' / in.	CHECKED -	REVISED -
	PLOT DATE = 10/27/2014	DATE -	REVISED -

**STATE OF ILLINOIS  
DEPARTMENT OF TRANSPORTATION**

**SCHEDULE OF QUANTITIES**

SCALE: N/A      SHEET 2 OF 2 SHEETS      STA.      TO STA.

• D7 Bridge Repairs 2015-3

F.A.I. RTE.	SECTION	COUNTY	TOTAL SHEETS	SHEET NO.
57	•	CUMBERLAND	30	7
CONTRACT NO.			74647	
ILLINOIS FED. AID PROJECT				

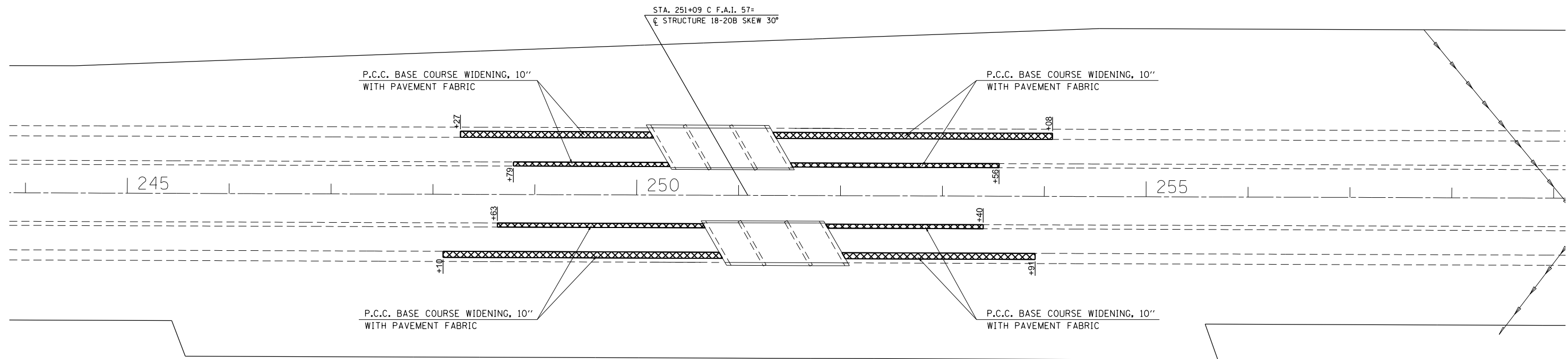
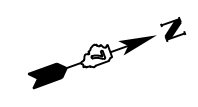

PAVED SHOULDER REMOVAL

• D7 Bridge Repairs 2015-3

FILE NAME =	USER NAME = steffenmk	DESIGNED -	REVISED -
c:\pw\work\p\dot\steffenmk\d0368705\074647-sht-plan.dgn	74647-sht-plan.dgn	DRAWN -	REVISED -
Default	PLOT SCALE = 100.0000' / in.	CHECKED -	REVISED -
	PLOT DATE = 10/27/2014	DATE -	REVISED -

**STATE OF ILLINOIS  
DEPARTMENT OF TRANSPORTATION**

**PLAN**

SCALE: 50      SHEET 1 OF 1 SHEETS      STA. 244+00 TO STA. 259+00

F.A.I. RTE.	SECTION	COUNTY	TOTAL SHEETS	SHEET NO.
57	•	CUMBERLAND	30	8
CONTRACT NO. 74647			ILLINOIS FED. AID PROJECT	



# STAGE 1

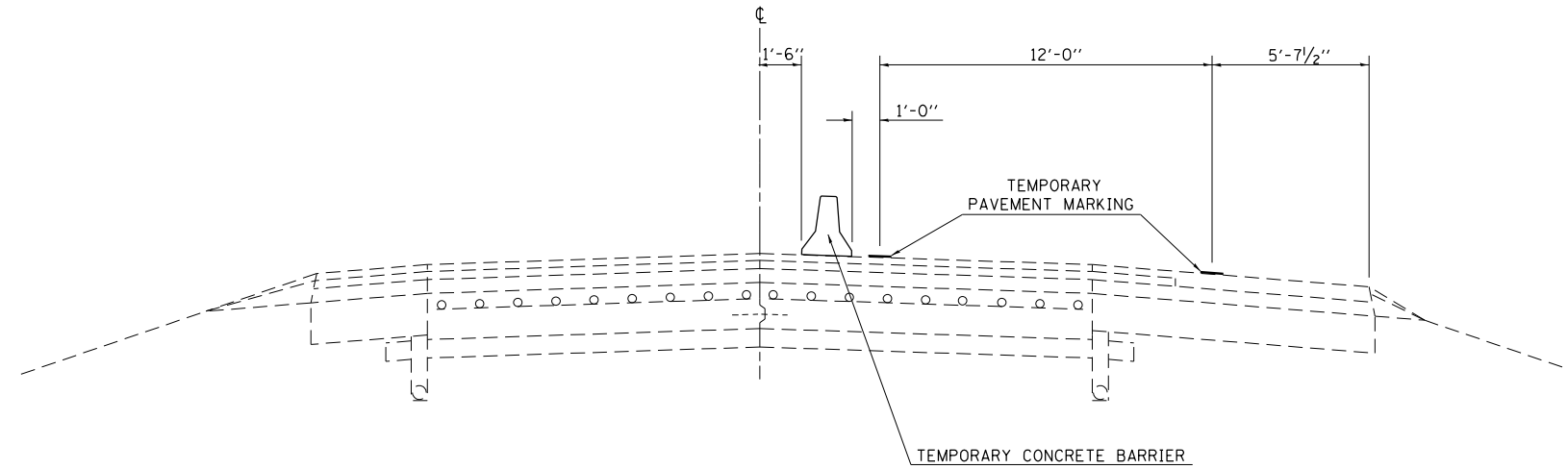

**NOTE:**  
ALL TEMPORARY PAVEMENT MARKING AND ITS REMOVAL SHALL BE INCLUDED IN THE COST OF TRAFFIC CONTROL AND PROTECTION, STANDARD 701402

**NOTE:** NOT TO SCALE

# STAGE 2

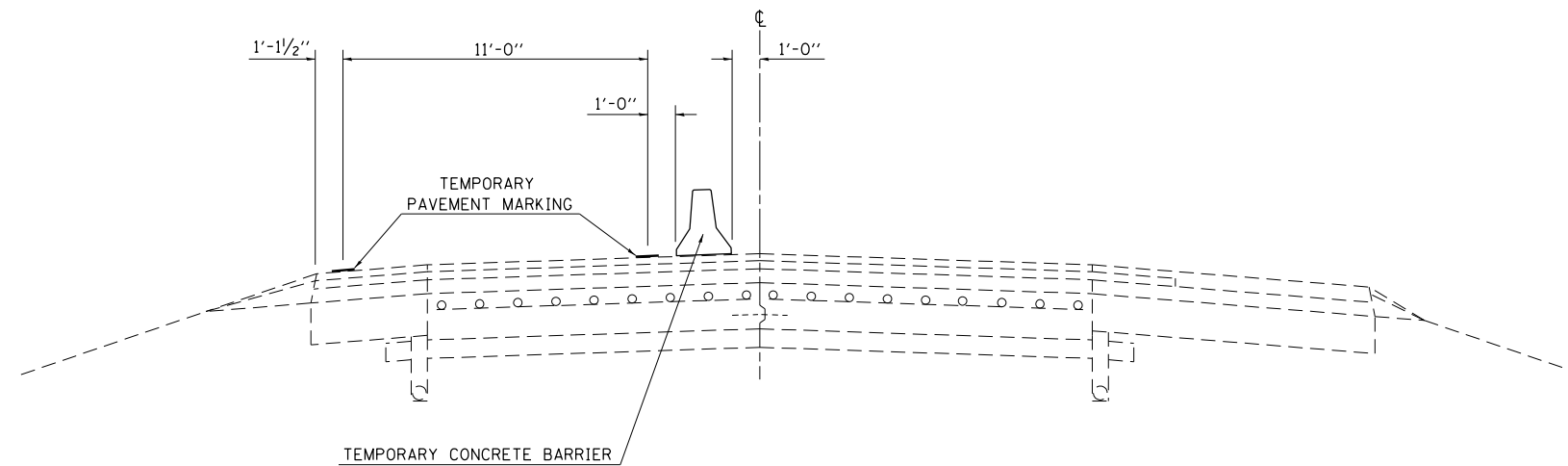

**NOTE:**  
ALL TEMPORARY PAVEMENT MARKING AND ITS REMOVAL SHALL BE INCLUDED IN THE COST OF TRAFFIC CONTROL AND PROTECTION, STANDARD 701402

**NOTE:** NOT TO SCALE

FILE NAME =	USER NAME = steffenmk	DESIGNED -	REVISED -
c:\pwork\pwork\stevfenmk\d0368705\074647-sht-trafficcontrol.dgn		DRAWN -	REVISED -
Default	PLOT SCALE = 100.0000' / in.	CHECKED -	REVISED -
	PLOT DATE = 10/27/2014	DATE -	REVISED -

**STATE OF ILLINOIS  
DEPARTMENT OF TRANSPORTATION**

## STAGE CONSTRUCTION DETAILS

SCALE: N/A SHEET 1 OF 1 SHEETS STA. TO STA.



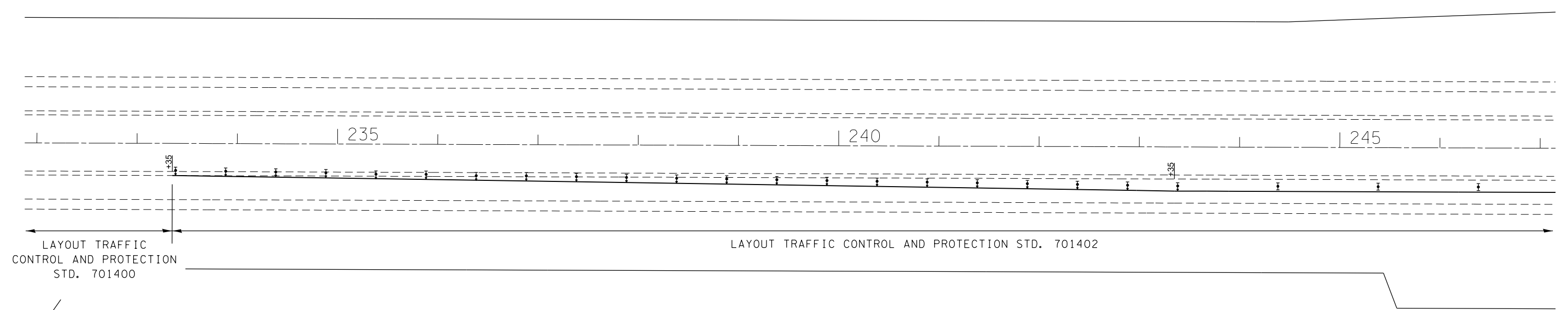
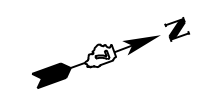

• 07 Bridge Repairs 2015-3				
F.A.I. RTE.	SECTION	COUNTY	TOTAL SHEETS	SHEET NO.
57	•	CUMBERLAND	30	9
			CONTRACT NO. 74647	
ILLINOIS FED. AID PROJECT				



LAYOUT TRAFFIC CONTROL AND PROTECTION STD. 701400

LAYOUT TRAFFIC CONTROL AND PROTECTION STD. 701402

**LEGEND**

-  DIRECTIONAL INDICATOR BARRICADE W/STEADY BURN MONODIRECTIONAL LIGHT
-  TYPE II BARRICADE DRUM OR VERTICAL BARRICADE W/STEADY BURN MONODIRECTIONAL LIGHT
-  IMPACT ATTENUATORS, TEMPORARY (NON-REDIRECTIVE) TEST LEVEL 3
-  TEMPORARY CONCRETE BARRIER

FILE NAME =	USER NAME = steffenmk	DESIGNED -	REVISED -
c:\pw\work\p1dot\stefjenmk\d0368705\074647-sht-trafficcontrol.dgn		DRAWN -	REVISED -
Default	PLOT SCALE = 100.0000' / in.	CHECKED -	REVISED -
	PLOT DATE = 10/27/2014	DATE -	REVISED -

**STATE OF ILLINOIS  
DEPARTMENT OF TRANSPORTATION**

**STAGE 1 TRAFFIC CONTROL**



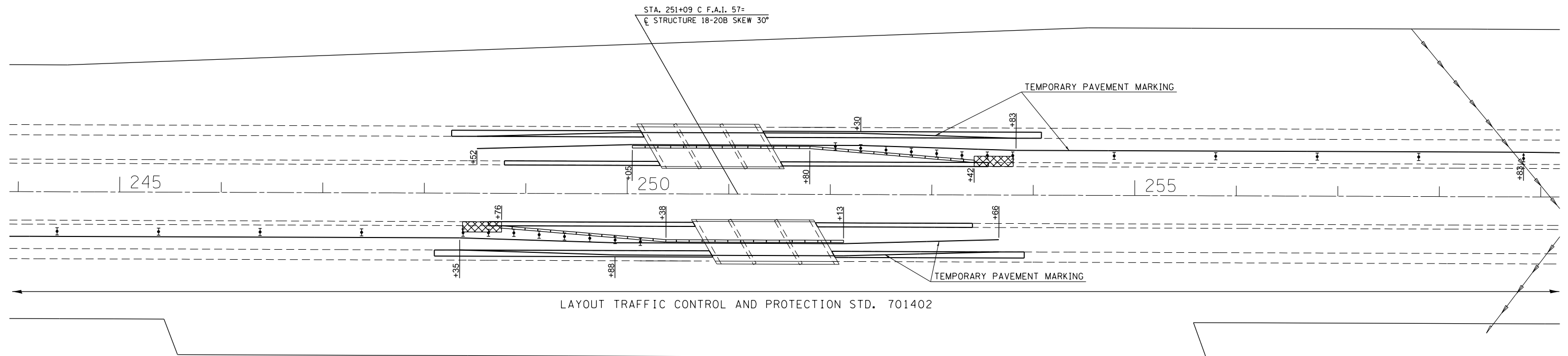

SCALE: 50 SHEET 1 OF 3 SHEETS STA. 232+00 TO STA. 247+00

• D7 Bridge Repairs 2015-3				
F.A.I. RTE.	SECTION	COUNTY	TOTAL SHEETS	SHEET NO.
57	•	CUMBERLAND	30	10
			CONTRACT NO. 74647	
ILLINOIS FED. AID PROJECT				



**NOTE:**  
 ALL TEMPORARY PAVEMENT MARKING AND ITS REMOVAL  
 SHALL BE INCLUDED IN THE COST OF TRAFFIC CONTROL  
 AND PROTECTION, STANDARD 701402

**LEGEND**

-  DIRECTIONAL INDICATOR BARRICADE W/STEADY BURN MONODIRECTIONAL LIGHT
-  TYPE II BARRICADE DRUM OR VERTICAL BARRICADE W/STEADY BURN MONODIRECTIONAL LIGHT
-  IMPACT ATTENUATORS, TEMPORARY (NON-REDIRECTIVE) TEST LEVEL 3
-  TEMPORARY CONCRETE BARRIER

• D7 Bridge Repairs 2015-3

FILE NAME =	USER NAME = steffenmk	DESIGNED -	REVISED -
c:\pw\work\p\dot\steffenmk\d0368705\074647-sht-trafficcontrol.dgn		DRAWN -	REVISED -
Default	PLOT SCALE = 100.0000' / in.	CHECKED -	REVISED -
	PLOT DATE = 10/27/2014	DATE -	REVISED -

**STATE OF ILLINOIS  
 DEPARTMENT OF TRANSPORTATION**



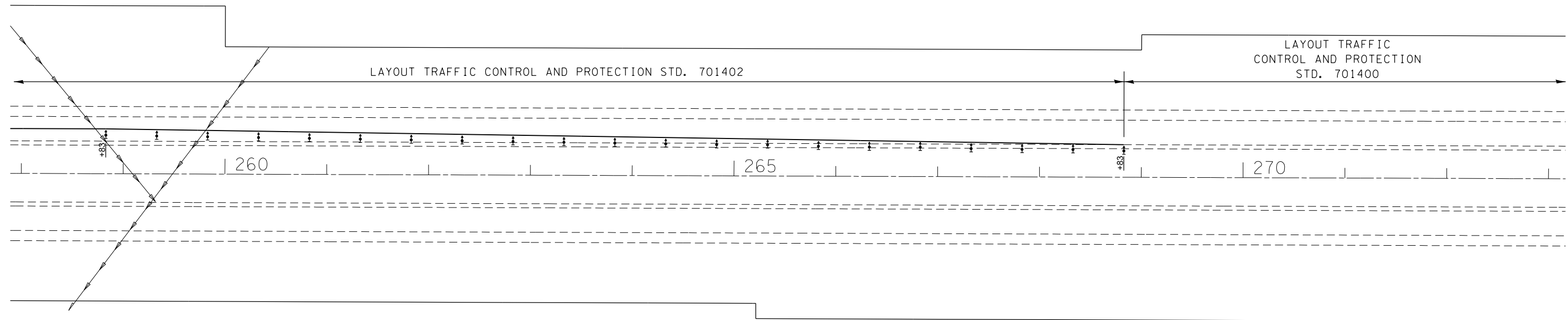
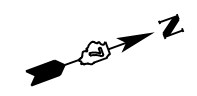

**STAGE 1 TRAFFIC CONTROL**

SCALE: 50 SHEET 2 OF 3 SHEETS STA. 244+00 TO STA. 259+00

F.A.I. RTE.	SECTION	COUNTY	TOTAL SHEETS	SHEET NO.
57	•	CUMBERLAND	30	11
CONTRACT NO. 74647			ILLINOIS FED. AID PROJECT	



**LEGEND**

- 
 DIRECTIONAL INDICATOR BARRICADE W/STEADY BURN MONODIRECTIONAL LIGHT
- 
 TYPE II BARRICADE DRUM OR VERTICAL BARRICADE W/STEADY BURN MONODIRECTIONAL LIGHT
- 
 IMPACT ATTENUATORS, TEMPORARY (NON-REDIRECTIVE) TEST LEVEL 3
- 
 TEMPORARY CONCRETE BARRIER

• D7 Bridge Repairs 2015-3

FILE NAME =	USER NAME = steffenmk	DESIGNED -	REVISED -
c:\pw\work\p1dot\steffenmk\d0368705\074647-sht-trafficcontrol.dgn		DRAWN -	REVISED -
Default	PLOT SCALE = 100.0000' / in.	CHECKED -	REVISED -
	PLOT DATE = 10/27/2014	DATE -	REVISED -

**STATE OF ILLINOIS  
DEPARTMENT OF TRANSPORTATION**

**STAGE 1 TRAFFIC CONTROL**

SCALE: 50      SHEET 3 OF 3 SHEETS      STA. 258+00 TO STA. 273+00



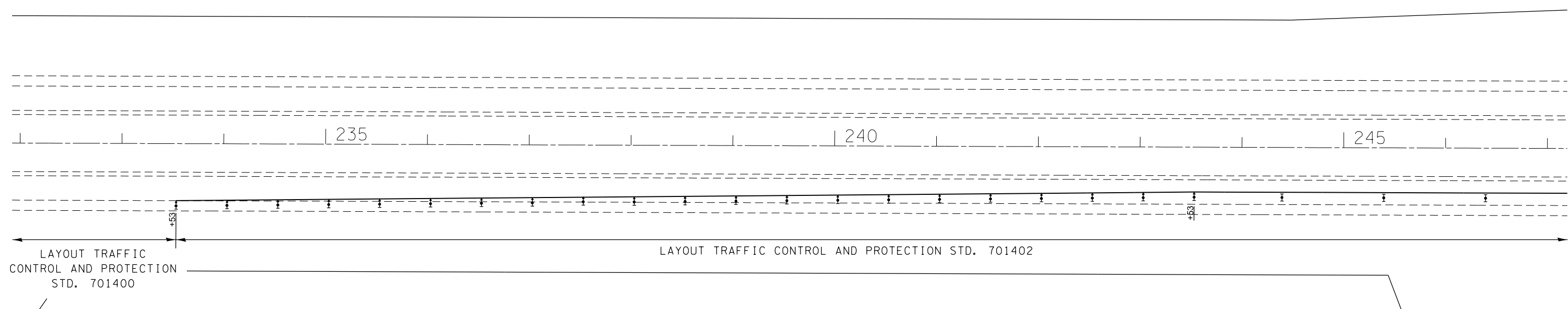

F.A.I. RTE.	SECTION	COUNTY	TOTAL SHEETS	SHEET NO.
57	•	CUMBERLAND	30	12
CONTRACT NO. 74647			ILLINOIS FED. AID PROJECT	



LAYOUT TRAFFIC CONTROL AND PROTECTION STD. 701400

LAYOUT TRAFFIC CONTROL AND PROTECTION STD. 701402

**LEGEND**

-  DIRECTIONAL INDICATOR BARRICADE W/STEADY BURN MONODIRECTIONAL LIGHT
-  TYPE II BARRICADE DRUM OR VERTICAL BARRICADE W/STEADY BURN MONODIRECTIONAL LIGHT
-  IMPACT ATTENUATORS, TEMPORARY (NON-REDIRECTIVE) TEST LEVEL 3
-  TEMPORARY CONCRETE BARRIER

FILE NAME =	USER NAME = steffenmk	DESIGNED -	REVISED -
c:\pw\work\p\idot\stefjenmk\d0368705\074647-sht-trafficcontrol.dgn		DRAWN -	REVISED -
Default	PLOT SCALE = 100.0000' / in.	CHECKED -	REVISED -
	PLOT DATE = 10/27/2014	DATE -	REVISED -

**STATE OF ILLINOIS  
DEPARTMENT OF TRANSPORTATION**

**STAGE 2 TRAFFIC CONTROL**



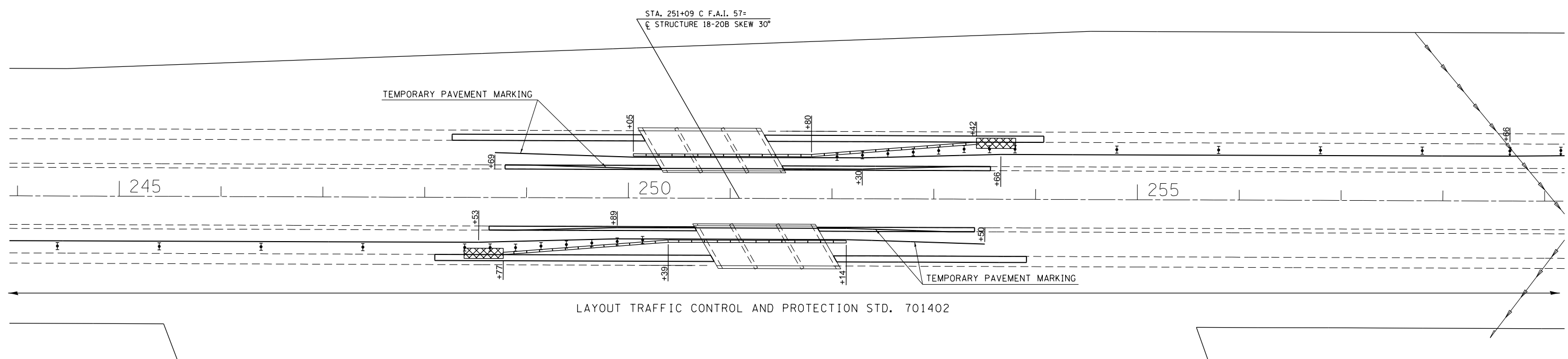
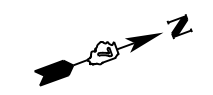

SCALE: 50 SHEET 1 OF 3 SHEETS STA. 232+00 TO STA. 247+00

• D7 Bridge Repairs 2015-3			
F.A.I. RTE.	SECTION	COUNTY	TOTAL SHEETS
57	•	CUMBERLAND	30
			SHEET NO. 13
			CONTRACT NO. 74647
ILLINOIS FED. AID PROJECT			



**NOTE:**  
 ALL TEMPORARY PAVEMENT MARKING AND ITS REMOVAL SHALL BE INCLUDED IN THE COST OF TRAFFIC CONTROL AND PROTECTION, STANDARD 701402

**LEGEND**

-  DIRECTIONAL INDICATOR BARRICADE W/STEADY BURN MONODIRECTIONAL LIGHT
-  TYPE II BARRICADE DRUM OR VERTICAL BARRICADE W/STEADY BURN MONODIRECTIONAL LIGHT
-  IMPACT ATTENUATORS, TEMPORARY (NON-REDIRECTIVE) TEST LEVEL 3
-  TEMPORARY CONCRETE BARRIER

• D7 Bridge Repairs 2015-3

FILE NAME =	USER NAME = steffenmk	DESIGNED -	REVISED -
c:\pwork\pwork\pwork\steffenmk\d0368705\074647-sht-trafficcontrol.dgn		DRAWN -	REVISED -
Default	PLOT SCALE = 100.0000' / in.	CHECKED -	REVISED -
	PLOT DATE = 10/27/2014	DATE -	REVISED -

**STATE OF ILLINOIS  
 DEPARTMENT OF TRANSPORTATION**



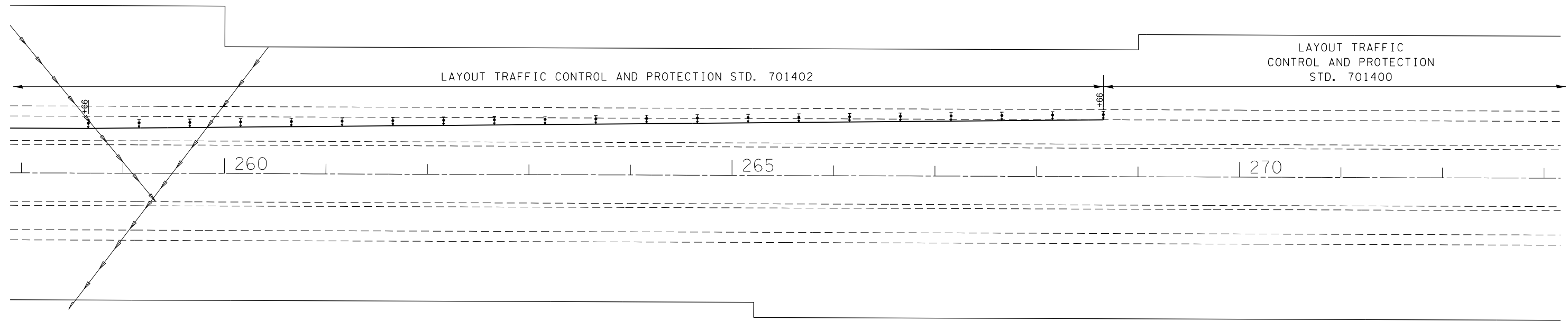

**STAGE 2 TRAFFIC CONTROL**

SCALE: 50 SHEET 2 OF 3 SHEETS STA. 244+00 TO STA. 259+00

F.A.I. RTE.	SECTION	COUNTY	TOTAL SHEETS	SHEET NO.
57	•	CUMBERLAND	30	14
CONTRACT NO. 74647			ILLINOIS FED. AID PROJECT	



**LEGEND**

- 
 DIRECTIONAL INDICATOR BARRICADE W/STEADY BURN MONODIRECTIONAL LIGHT
- 
 TYPE II BARRICADE DRUM OR VERTICAL BARRICADE W/STEADY BURN MONODIRECTIONAL LIGHT
- 
 IMPACT ATTENUATORS, TEMPORARY (NON-REDIRECTIVE) TEST LEVEL 3
- 
 TEMPORARY CONCRETE BARRIER

FILE NAME =	USER NAME = steffenmk	DESIGNED -	REVISED -
c:\pw\work\p\dot\steffenmk\d0368705\074647-sht-trafficcontrol.dgn		DRAWN -	REVISED -
Default	PLOT SCALE = 100.0000' / in.	CHECKED -	REVISED -
	PLOT DATE = 10/27/2014	DATE -	REVISED -

**STATE OF ILLINOIS  
DEPARTMENT OF TRANSPORTATION**

**STAGE 2 TRAFFIC CONTROL**

SCALE: 50      SHEET 3 OF 3 SHEETS      STA. 258+00 TO STA. 273+00

• D7 Bridge Repairs 2015-3		TOTAL SHEETS	SHEET NO.
F.A.I. RTE.	SECTION	COUNTY	
57	•	CUMBERLAND	30 15
		CONTRACT NO.	74647
ILLINOIS FED. AID PROJECT			

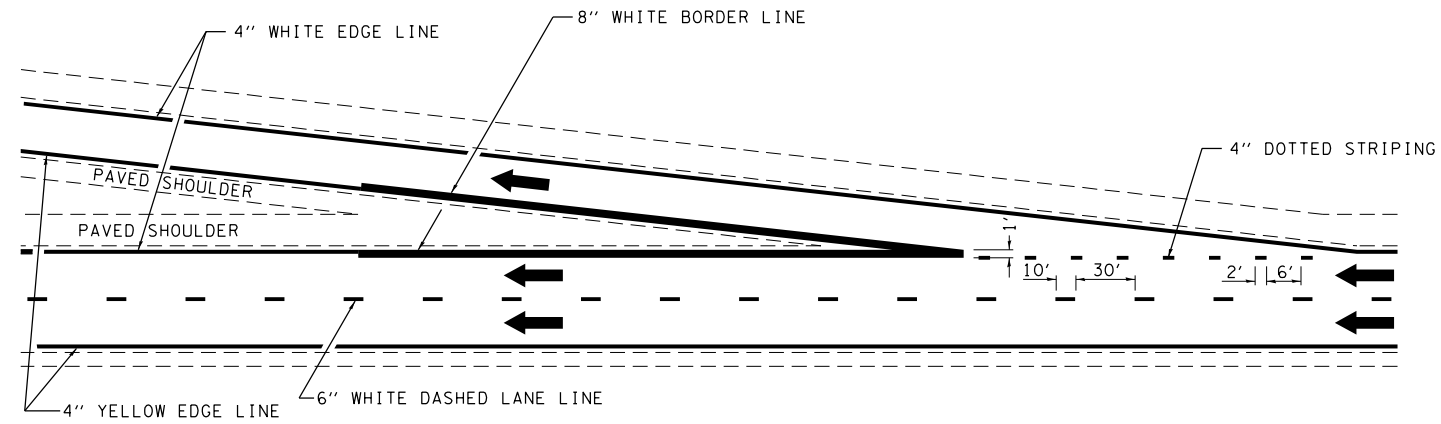

TYPICAL EXIT RAMP MARKING

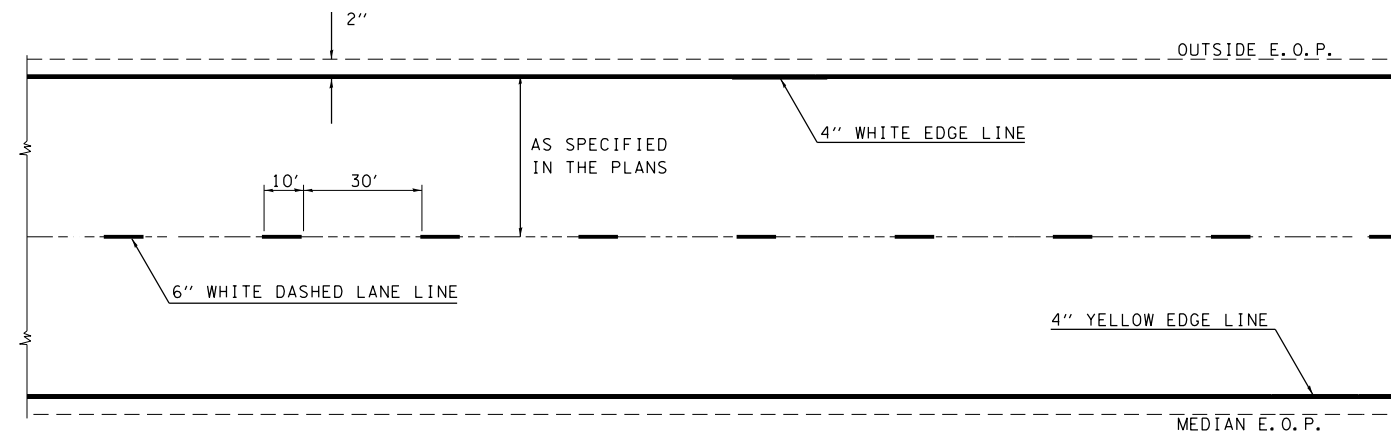

TYPICAL CENTERLINE & EDGELINE MARKINGS

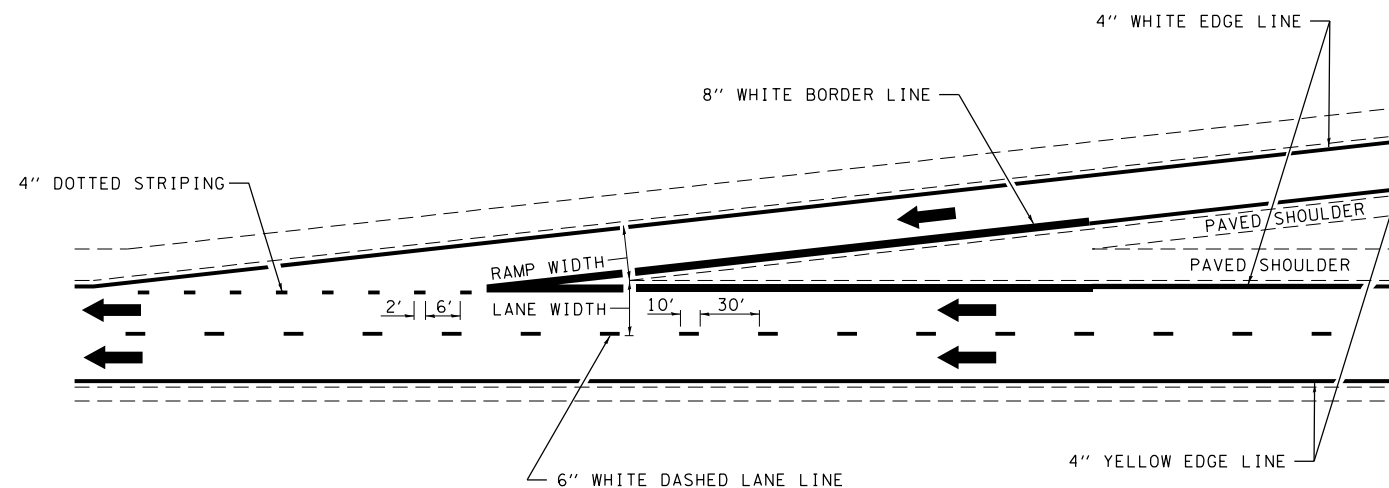

TYPICAL ENTRANCE RAMP MARKING

NOT TO SCALE

• D7 Bridge Repairs 2015-3

**DISTRICT 7 DETAIL NO. 7800002**

FILE NAME =	USER NAME = steffenmk	DESIGNED -	REVISED - DRM 08-04
ei:\pwork\pwork\stevfenmk\d0368705\074647-sht-details.dgn		DRAWN -	REVISED - MKS 04-08
	PLOT SCALE = 100.0000' / in.	CHECKED -	REVISED - DRM 01-09
	PLOT DATE = 10/27/2014	DATE -	REVISED - DRM 12-10

**STATE OF ILLINOIS  
DEPARTMENT OF TRANSPORTATION**

**TYPICAL APPLICATIONS OF INTERSTATE PAVEMENT MARKING**

SCALE: N/A SHEET NO. 1 OF 2 SHEETS STA. TO STA.

F.A.I. RTE.	SECTION	COUNTY	TOTAL SHEETS	SHEET NO.
57	•	CUMBERLAND	30	16
CONTRACT NO. 74647				
FED. ROAD DIST. NO. ILLINOIS FED. AID PROJECT				



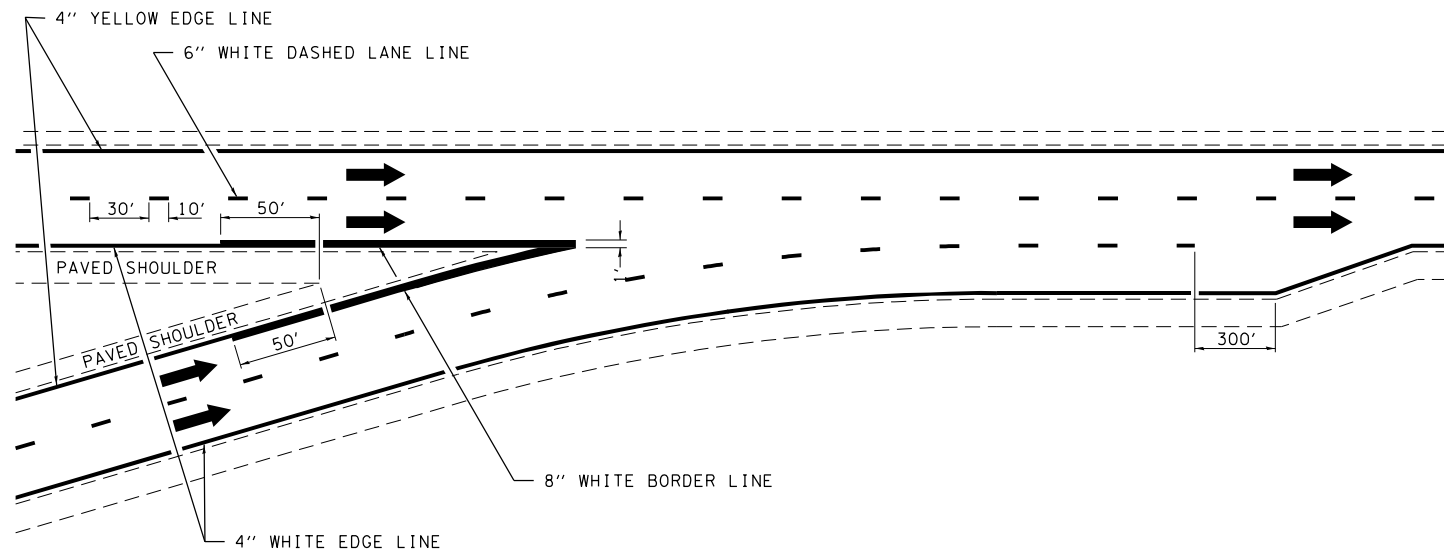

TYPICAL CONVERGENCE MARKING

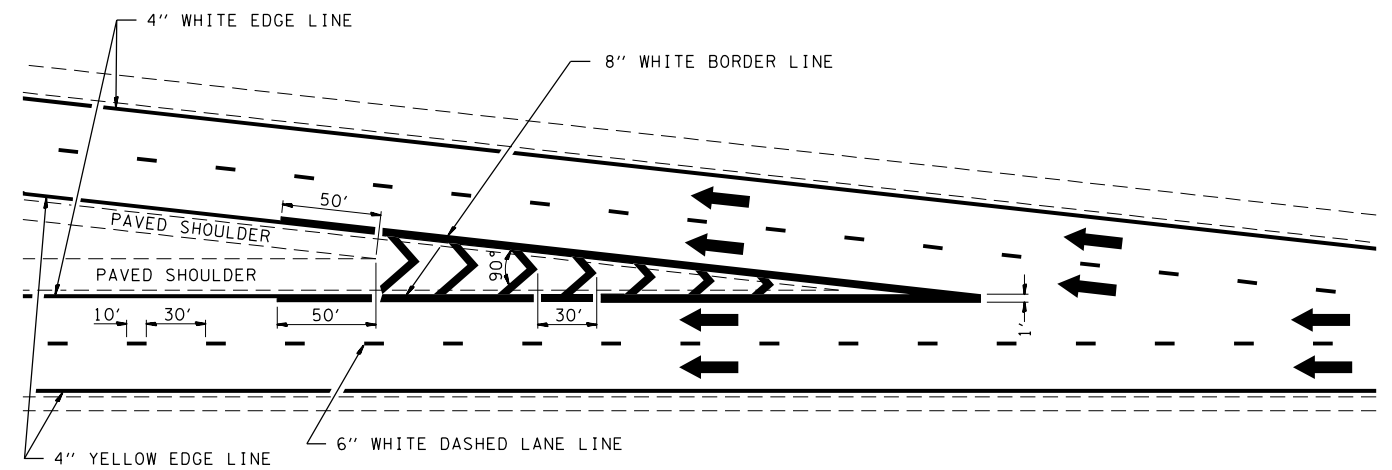

TYPICAL DIVERGENCE MARKING

AERIAL SPEED CHECK ZONES

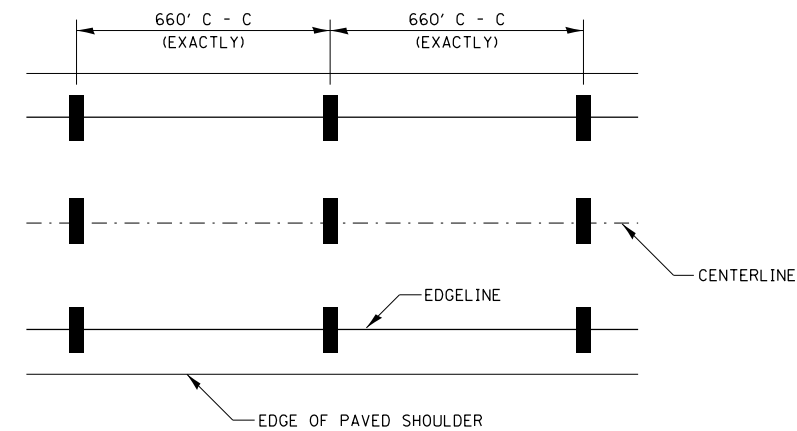

IT WILL BE NECESSARY TO HAVE A REPRESENTATIVE OF THE STATE POLICE PRESENT SO THAT THE ACCURACY OF MEASUREMENT CAN BE ATTESTED TO IN COURT.

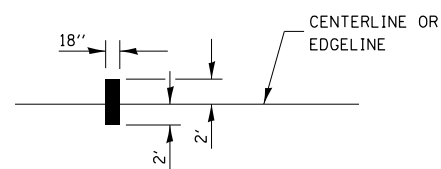

NOT TO SCALE

• D7 Bridge Repairs 2015-3

**DISTRICT 7 DETAIL NO. 7800002**

FILE NAME =	USER NAME = steffenmk	DESIGNED -	REVISED - MMO 12-99
et:\pw\work\p\id\dot\steffenmk\d0368705\074647-sht-details.dgn		DRAWN -	REVISED - DRM 08-04
	PLOT SCALE = 100.0000' / in.	CHECKED -	REVISED - MKS 04-08
	PLOT DATE = 10/27/2014	DATE -	REVISED - DRM 01-09

**STATE OF ILLINOIS  
DEPARTMENT OF TRANSPORTATION**

**TYPICAL APPLICATIONS OF INTERSTATE PAVEMENT MARKING**

SCALE: N/A SHEET NO. 2 OF 2 SHEETS STA. TO STA.

F.A.I. RTE.	SECTION	COUNTY	TOTAL SHEETS	SHEET NO.
57	•	CUMBERLAND	30	17
CONTRACT NO. 74647				
FED. ROAD DIST. NO. ILLINOIS FED. AID PROJECT				

The existing three span continuous concrete T-beam dual structures were constructed in 1964 as FAI-57 section 18-20B at Sta. 251+09.00. SN. 018-0005 carries FAI-57 (Interstate 57 Southbound) over Bush Creek. SN. 018-0006 carries FAI-57 (Interstate 57 Northbound) over Bush Creek. The proposed project consists of new expansion joints, new elastomeric bearings, bridge deck repair, new concrete overlay, and structural repair of concrete.

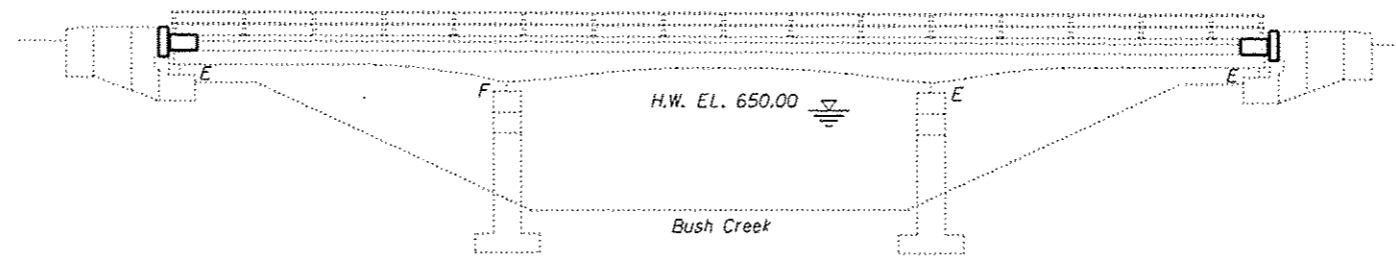

ELEVATION

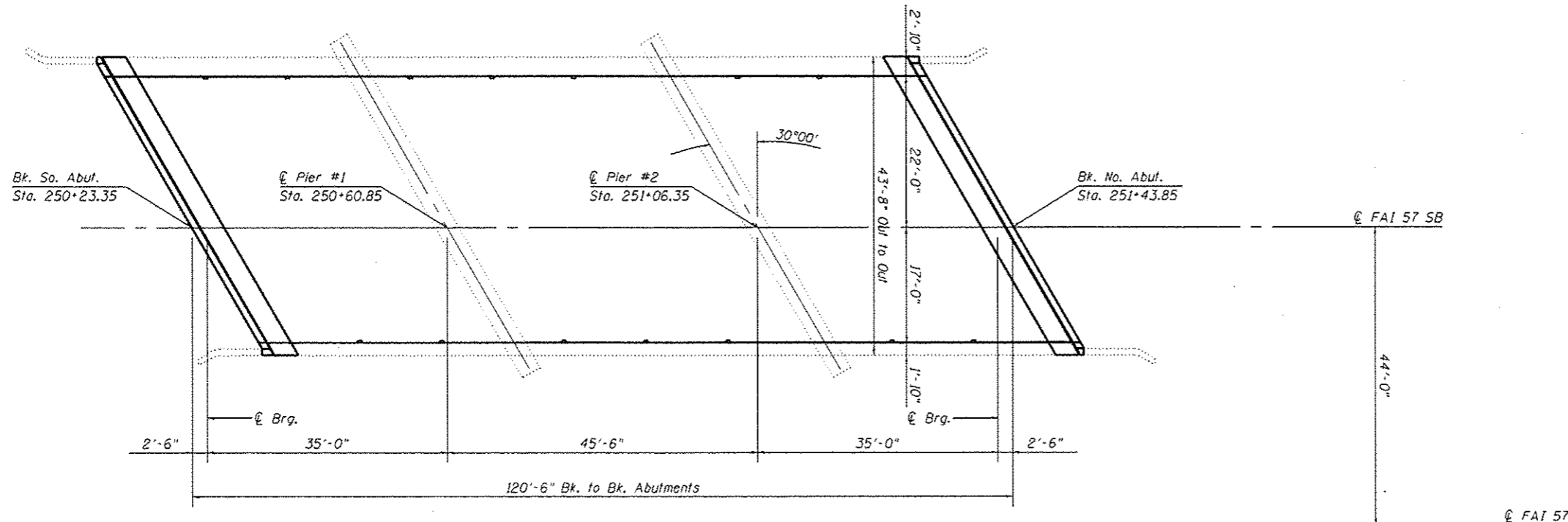

**DESIGN STRESSES**  
 Existing:  
 $f_c = 1400 \text{ psi}$   
 $f_s = 20,000 \text{ psi. (Reinf.)}$   
 $f_s = 20,000 \text{ psi. (Struct.)}$   
 $v_{max} = 75 \text{ psi. (Pier Footings)}$   
 $n = 10$   
 New (Field Units):  
 $f_c' = 3,500 \text{ psi}$   
 $f_y = 60,000 \text{ psi. (Reinf.)}$   
 $f_y = 36,000 \text{ psi. (M270 Grade 36)}$   
 Loading H20-S16-44  
 & Alternate Loading

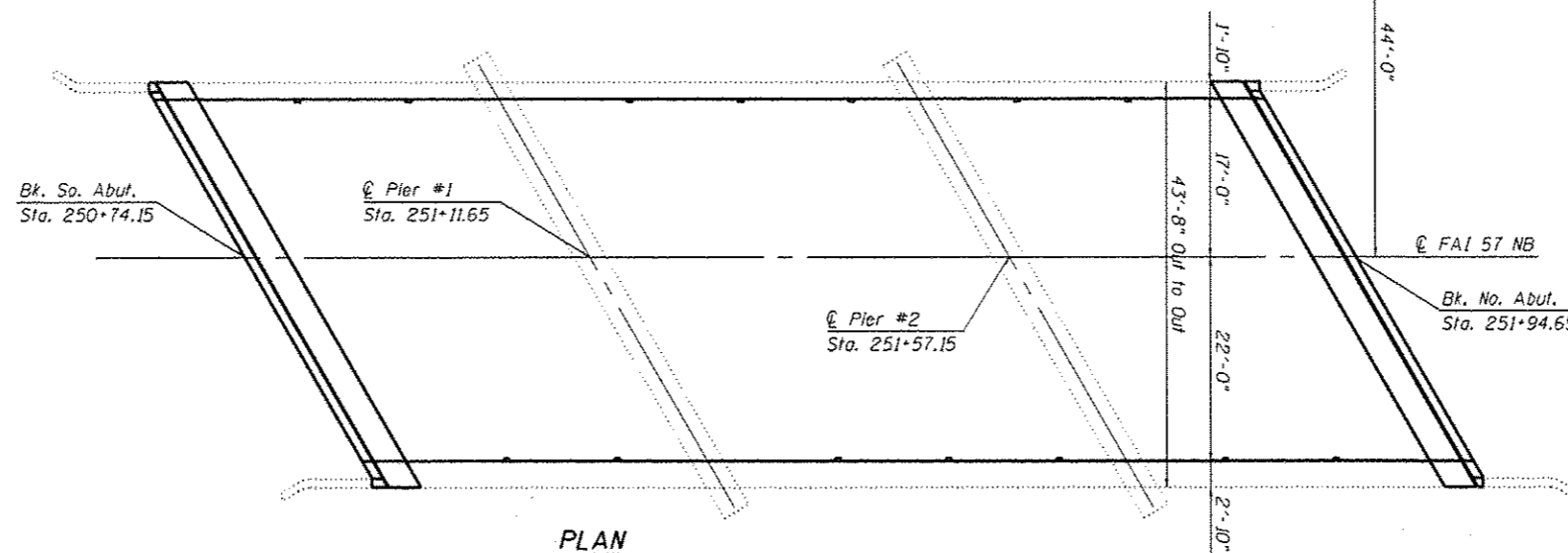

PLAN



*David Carl Puzey* 12/4/14  
 Expires 11/30/16

FILE NAME =	USER NAME = hrtzsk1	DESIGNED - JKS	REVISED -	<b>STATE OF ILLINOIS DEPARTMENT OF TRANSPORTATION</b>	<b>GENERAL PLAN &amp; ELEVATION</b>		F.A.I. RTE.	SECTION	COUNTY	TOTAL SHEETS	SHEET NO.
c:\pwork\p1d0\hrtzsk1\030604\07	#47-structures-018000506.dgn	DRAWN - 01/16/2014	REVISED -		S.N. 018-0005 (SB) & S.N. 018-0006 (NB)		57	07 BRIDGE REPAIRS 2015-3	CUMBERLAND	30	18
Default	PLOT SCALE = 40.0000 1/16"	CHECKED - MEA	REVISED -		SCALE: N/A	SHEET 1	OF 13 SHEETS	STA.	TO STA.	CONTRACT NO. 74647	
	PLOT DATE = 12/4/2014	DATE - 1/23/2014	REVISED -		ILLINOIS FED. AID PROJECT						

**GENERAL NOTES**

Plan dimensions and details relative to existing plans are subject to nominal construction variations. The Contractor shall field verify existing dimensions and details affecting new construction and make necessary approved adjustments prior to construction or ordering of materials. Such variations shall not be cause for additional compensation for a change in scope of work, however, the Contractor will be paid for the quantity actually furnished at the unit price bid for the work.

Reinforcement Bars designated (E) shall be epoxy coated.

Existing reinforcement bars extending into the removal area shall be cleaned, straightened and incorporated into the new construction. Any reinforcement bars that are damaged during concrete removal operations shall be replaced using an approved bar splicer or anchorage system. Cost included in CONCRETE REMOVAL.

Joint openings shall be adjusted according to Article 520.04 of the Standard Specifications when the deck is poured at an ambient temperature other than 50°F.

Areas of deck repairs shown are estimated. The Engineer shall show actual locations of deck repairs on as-built plans.

Removal and reinstallation of guardrail sections and sections of the original metal handrail will be necessary for construction of the expansion joints. All existing embedded anchors that are within the concrete removal area shall be cleaned and incorporated in the new construction or new approved alternatives shall be supplied and installed. This work and all materials shall be included in the contract unit price for CONCRETE REMOVAL.

All structural steel shall conform to AASHTO Classification M-270 Gr. 36 unless otherwise noted.

Protective Coat shall be applied to areas of Concrete Superstructure consisting of the front face and top of the wingwall and curb, and the top surface of the exposed expansion joint removal and replacement areas.

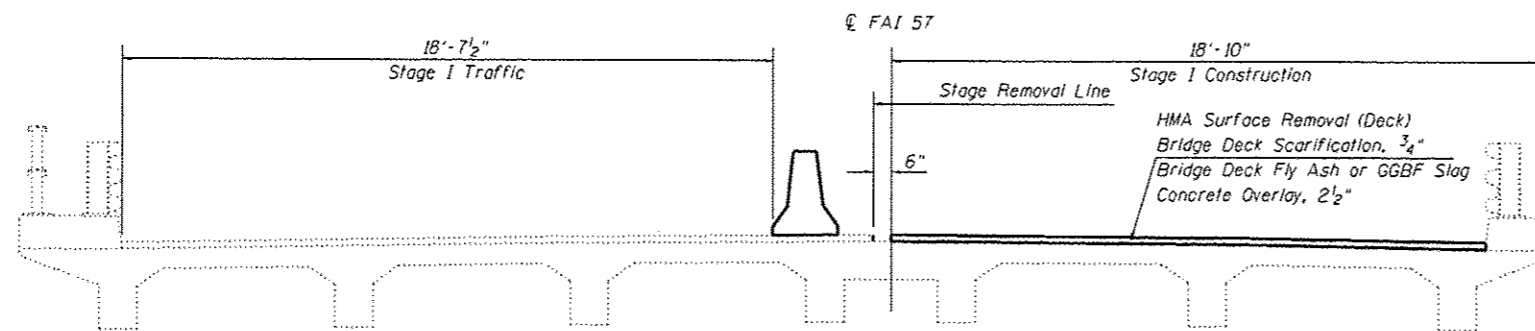

**STAGE I**

S.N. 018-0005 (SB) Looking North, S.N. 018-0006 (NB) Looking South

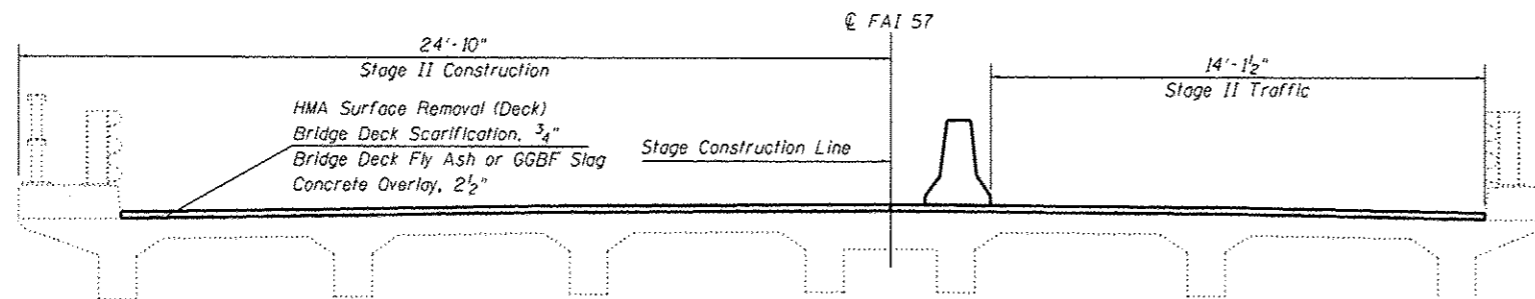

**STAGE II**

S.N. 018-0005 (SB) Looking North, S.N. 018-0006 (NB) Looking South

**TOTAL BILL OF MATERIALS**

S.N. 018-0005 (SB)

ITEM	UNIT	QUANTITY
Concrete Removal	Cu. Yd.	20.0
Concrete Superstructure	Cu. Yd.	20.0
Reinforcement Bars, Epoxy Coated	Pound	2460
Bar Splicers	Each	30
Preformed Joint Strip Seal	Foot	104.0
Plug Existing Deck Drains	Each	26
HMA Surface Removal (Deck)	Sq Yd	481
Bridge Deck Scarification, 3/4"	Sq Yd	481
Bridge Deck Fly Ash or GGBF Slag Concrete Overlay, 2 1/2"	Sq Yd	481
Bridge Deck Grooving	Sq Yd	489
Protective Coat	Sq Ft	49
Structural Repair of Concrete (Depth Less than or Equal to 5")	Sq Ft	21
Deck Slab Repair (Full Depth, Type I)	Sq Yd	0
Deck Slab Repair (Full Depth, Type II)	Sq Yd	50
Elastomeric Bearing Assembly, Type I	Each	7
Elastomeric Bearing Assembly, Type II	Each	7
Jack and Remove Existing Bearings	Each	14
Furnishing and Erecting Structural Steel	Pound	1970
Anchor Bolts, 1"φ	Each	28

**TOTAL BILL OF MATERIALS**

S.N. 018-0006 (NB)

ITEM	UNIT	QUANTITY
Concrete Removal	Cu. Yd.	20.0
Concrete Superstructure	Cu. Yd.	20.0
Reinforcement Bars, Epoxy Coated	Pound	2460
Bar Splicers	Each	30
Preformed Joint Strip Seal	Foot	104.0
Plug Existing Deck Drains	Each	26
HMA Surface Removal (Deck)	Sq Yd	481
Bridge Deck Scarification, 3/4"	Sq Yd	481
Bridge Deck Fly Ash or GGBF Slag Concrete Overlay, 2 1/2"	Sq Yd	481
Bridge Deck Grooving	Sq Yd	489
Protective Coat	Sq Yd	49
Deck Slab Repair (Full Depth, Type I)	Sq Yd	1
Deck Slab Repair (Full Depth, Type II)	Sq Yd	54
Elastomeric Bearing Assembly, Type I	Each	7
Elastomeric Bearing Assembly, Type II	Each	7
Jack and Remove Existing Bearings	Each	14
Furnishing and Erecting Structural Steel	Pound	1990
Anchor Bolts, 1"φ	Each	28

For Section A-A and B-B see Sheet 4 of 13.  
See Sheet 4 of 13 for Wingwall Details.  
Hatching Indicates removal.  
Field cut or bend Rebar to fit expansion joint.

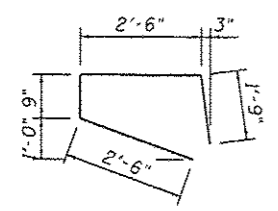

Bar d(E)

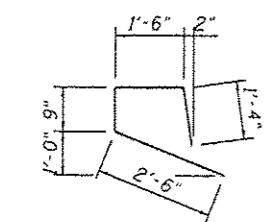

Bar d(E)

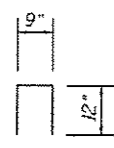

Bar u(E)

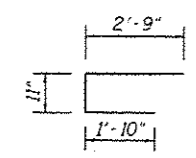

Bar x(E)

**BILL OF MATERIAL**  
PER ABUTMENT

BAR	NUMBER OF BARS		TOTAL	SIZE	LENGTH	SHAPE
	STAGE I	STAGE II				
c (E)		11	11	#5	27'-3"	—
cl (E)	11		11	#5	20'-3"	—
d (E)		4	4	#4	7'-6"	□
dl (E)	4		4	#4	6'-1"	□
h (E)		4	4	#6	28'-3"	—
hl (E)	4		4	#6	21'-4"	—
u (E)	26	20	46	#5	2'-10"	□
x (E)	26	20	46	#5	5'-6"	□
REINFORCEMENT BARS (EPOXY COATED)					POUND	1290
CONCRETE REMOVAL					CU YD	10.0
CONCRETE SUPERSTRUCTURE					CU YD	10.0

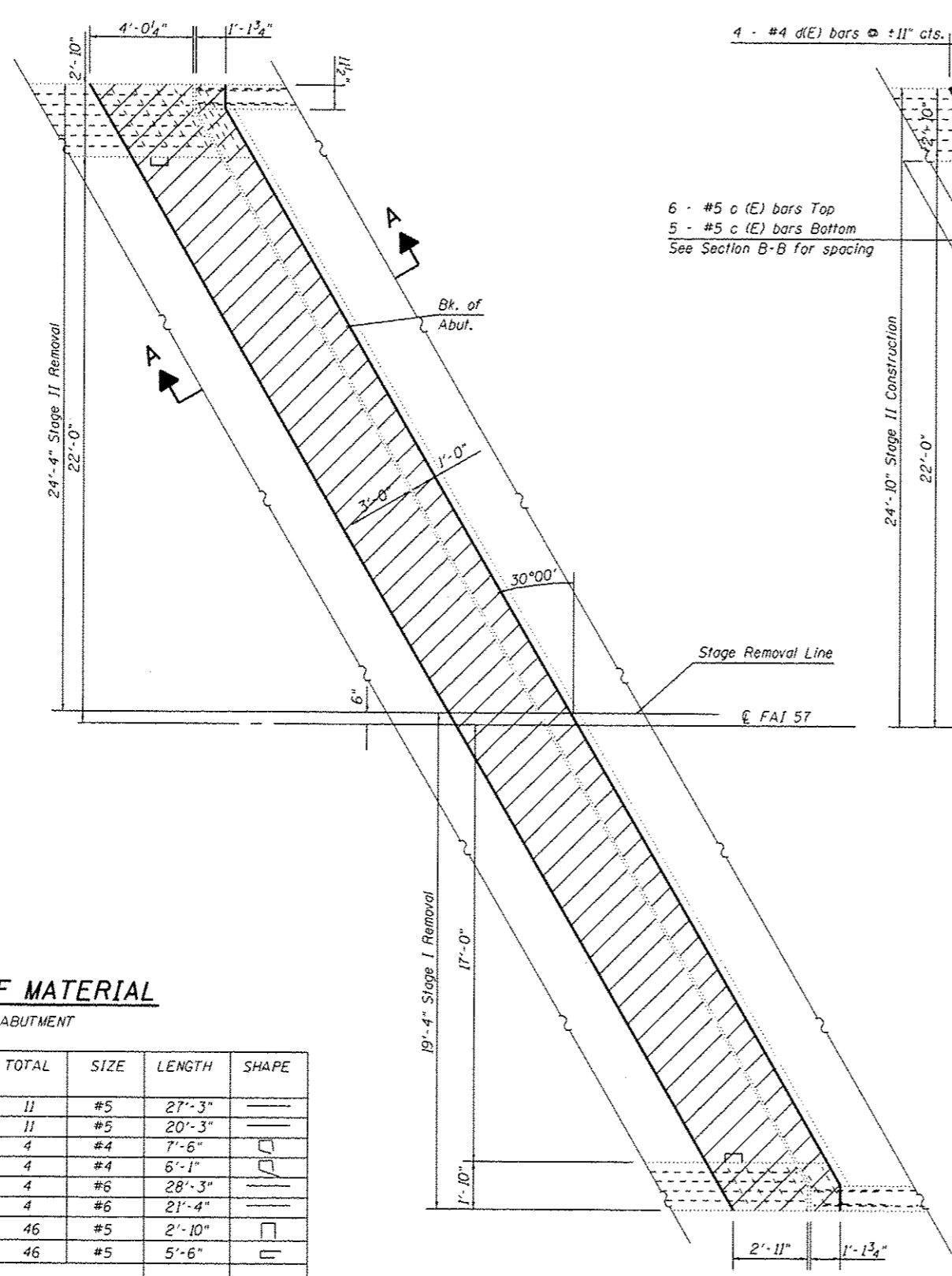

**EXISTING PARTIAL PLAN**

SN 018-0005 (SB) North Abutment Shown; South Abutment Similar by Rotation  
(SN 018-0006 (NB) Similar)

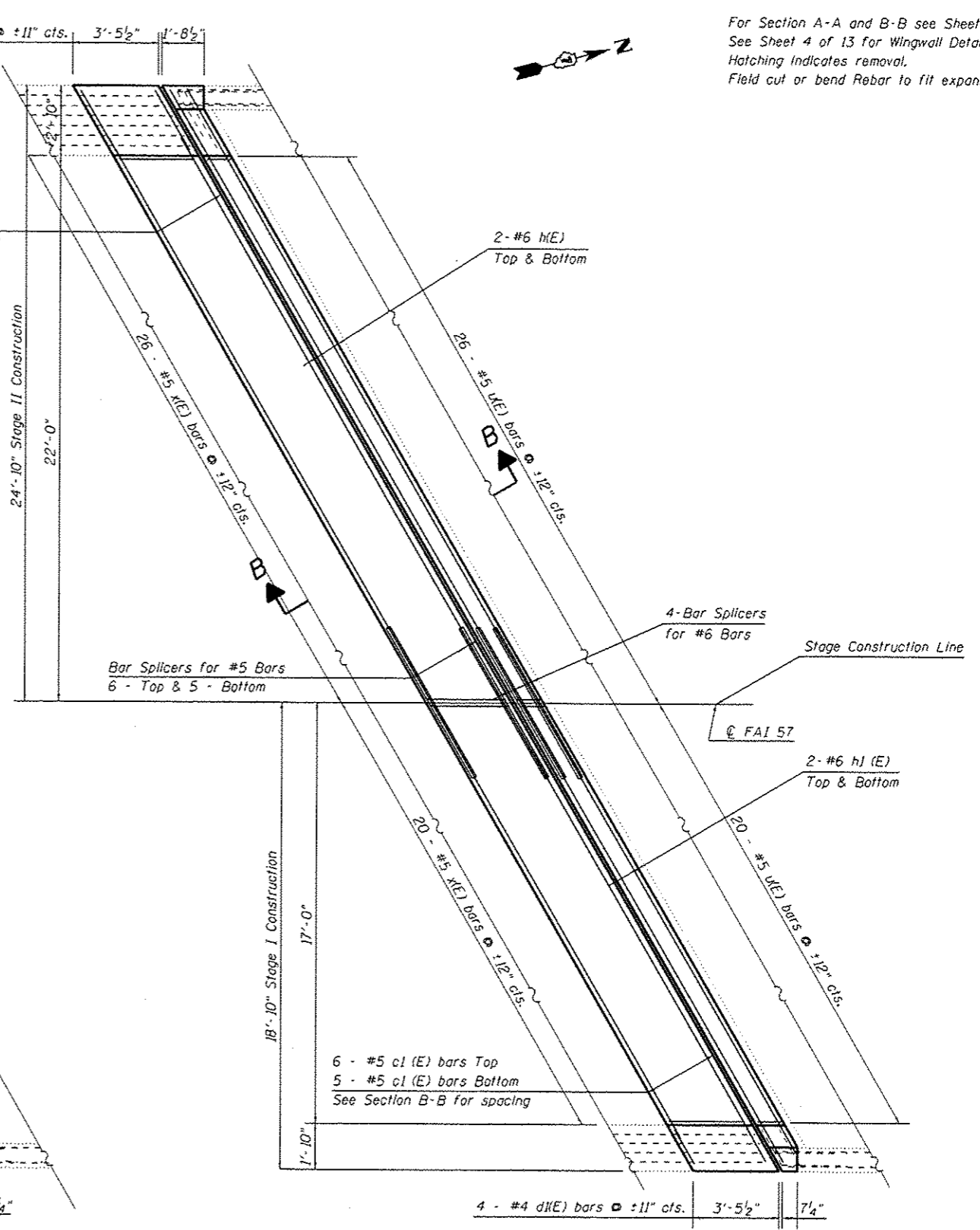

**PROPOSED PARTIAL PLAN**

SN 018-0005 (SB) North Abutment Shown; South Abutment Similar by Rotation  
(SN 018-0006 (NB) Similar)

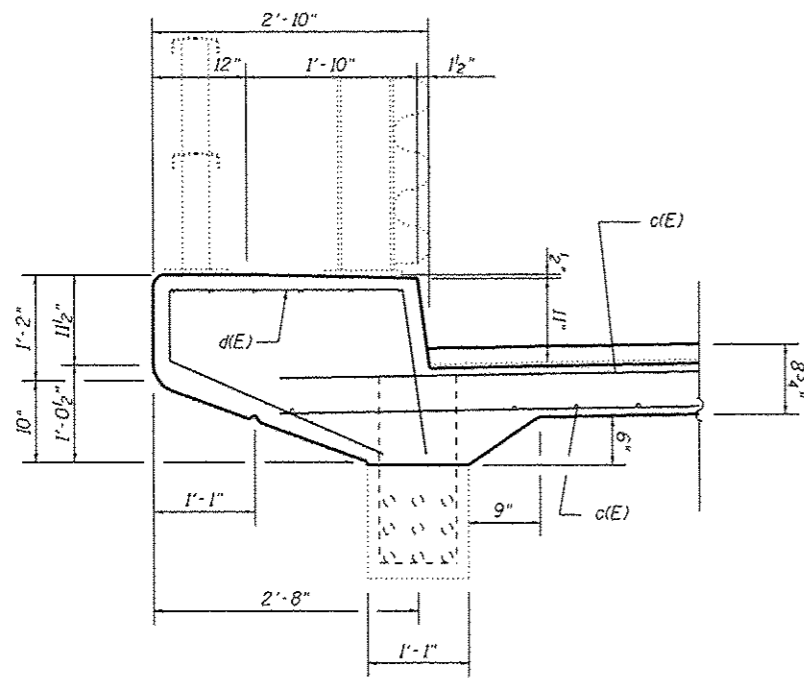

**SECTION THRU CURB**

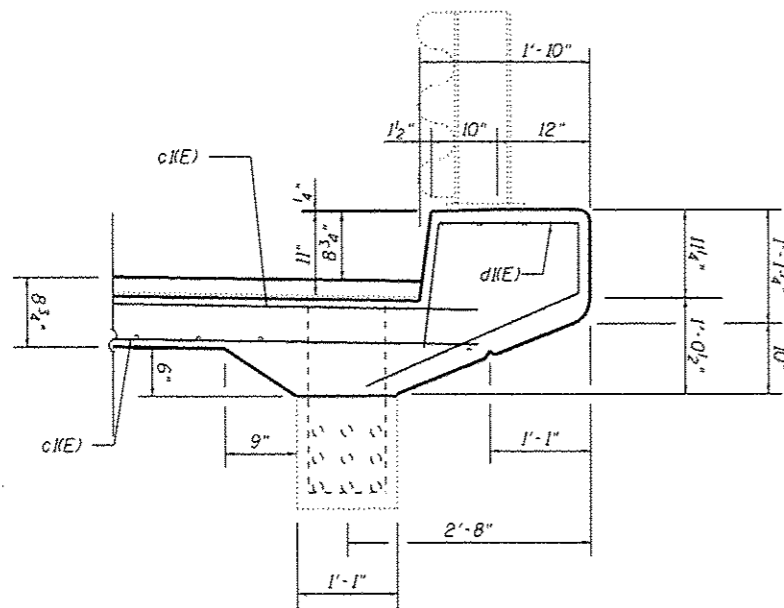

**SECTION THRU CURB**

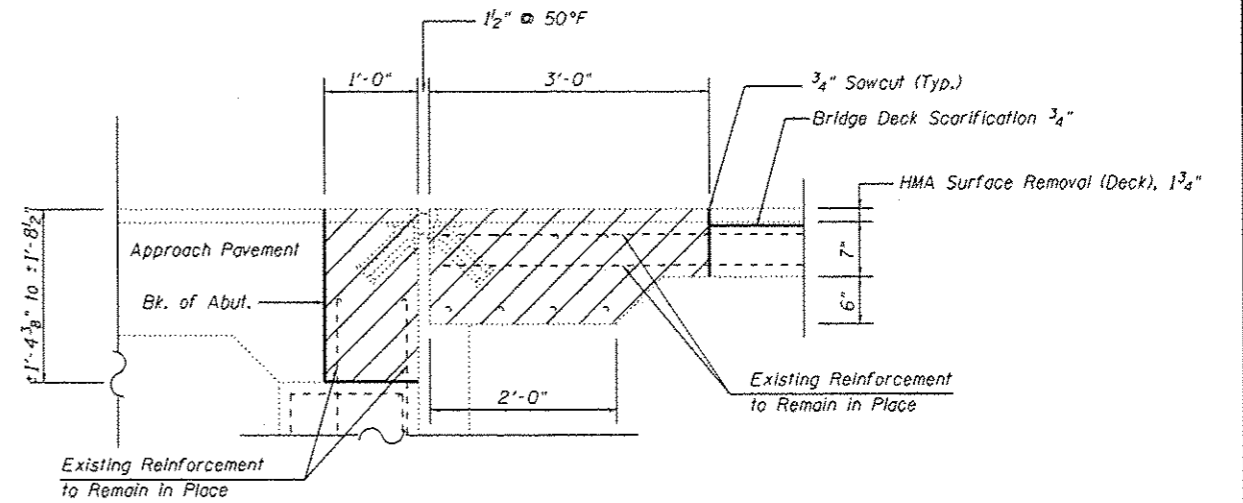

**SECTION A-A**  
(Dimensions at Rt. L's to end of deck)

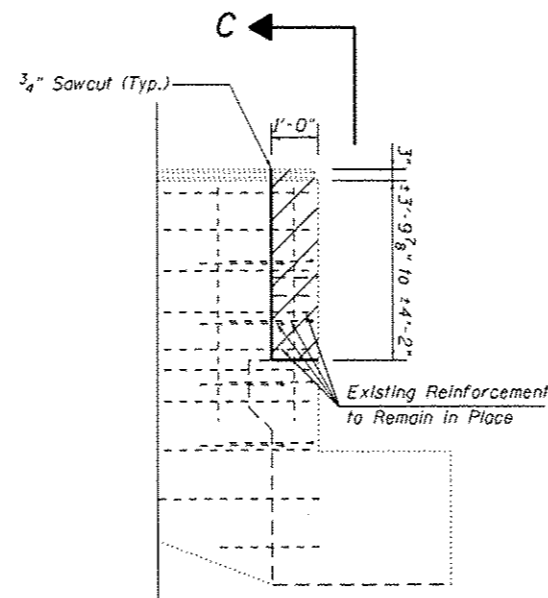

**TYPICAL WINGWALL  
REMOVAL & REPLACEMENT**

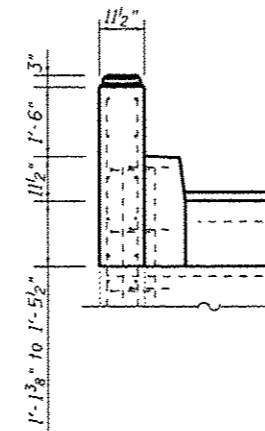

**VIEW C-C**

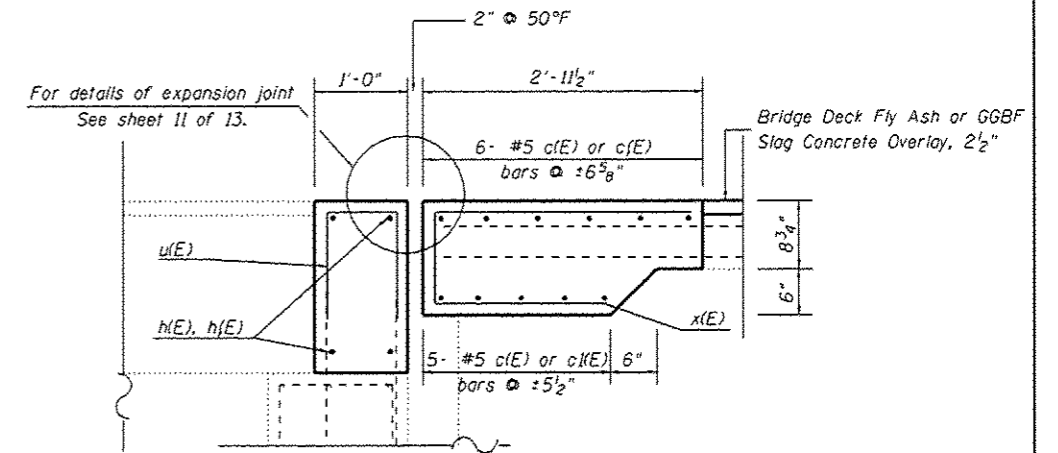

**SECTION B-B**  
(Dimensions at Rt. L's to end of deck)

Note: Removal and disposal of the existing expansion joint is included in the cost of CONCRETE REMOVAL. Strip Seal Joint is to be run up the safety walk and along the top of the curb. Hatching indicates removal.

- Existing Reinforcement
- Proposed Reinforcement

FILE NAME =	USER NAME = hirszelki	DESIGNED - JKS	REVISED -
c:\pwork\p\hirszelki\036894\07	ME47-structarea\010000506.dgn	DRAWN - 01/16/2014	REVISED -
Default	PLOT SCALE = 40.0000' / in.	CHECKED - MEA	REVISED -
	PLOT DATE = 12/4/2014	DATE - 1/24/2014	REVISED -

STATE OF ILLINOIS  
DEPARTMENT OF TRANSPORTATION

EXPANSION JOINT REPLACEMENT DETAILS  
S.N. 018-0005 (SB) & S.N. 018-0006 (NB)

SCALE: N/A SHEET 4 OF 13 SHEETS STA. TO STA.

F.A.I. RTE.	SECTION	COUNTY	TOTAL SHEETS	SHEET NO.
57	07 BRIDGE REPAIRS 2015-3	CUMBERLAND	30	21
			CONTRACT NO. 74647	
ILLINOIS FED. AID PROJECT				

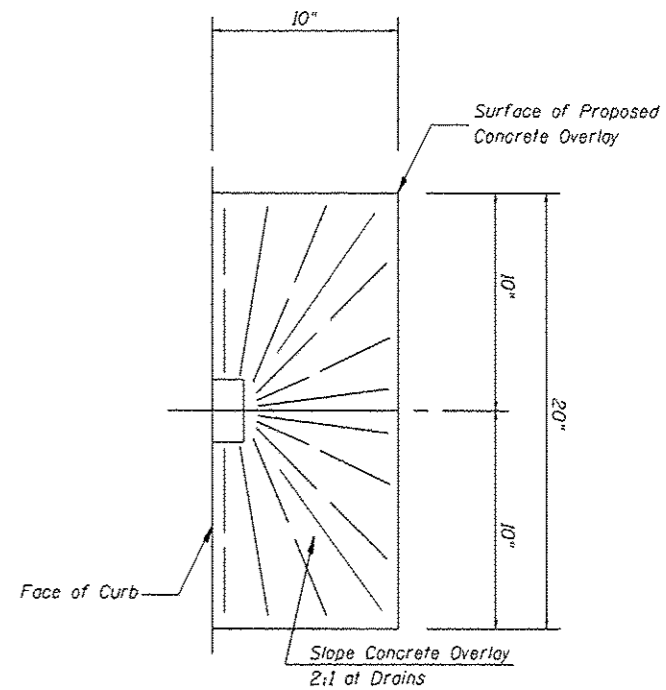
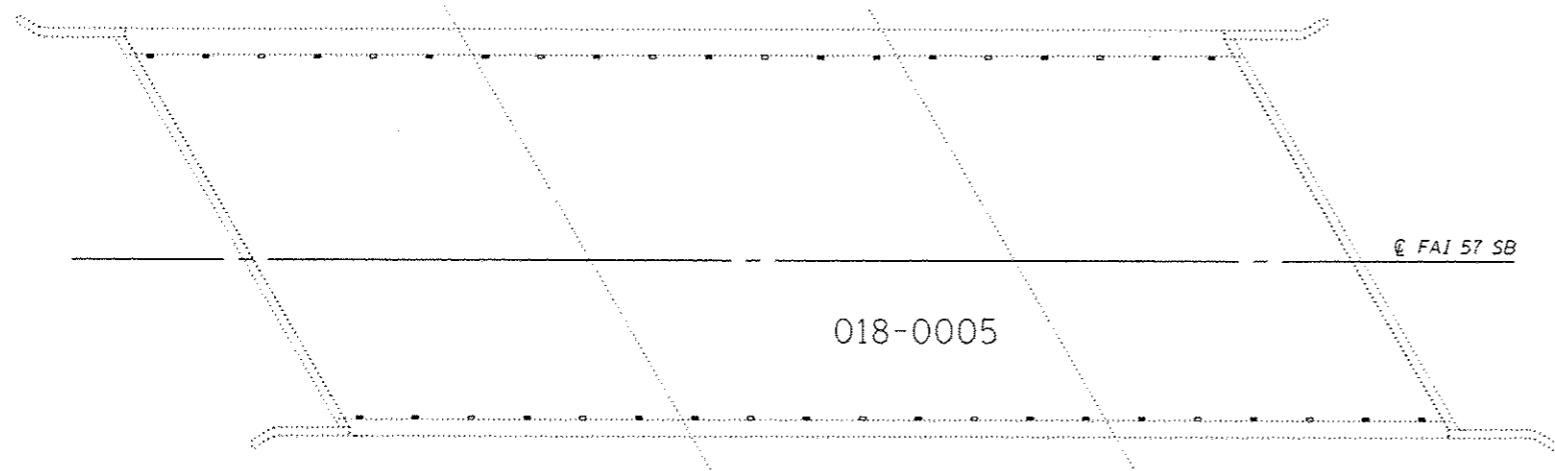

**DRAIN DETAIL  
TOP PLAN**

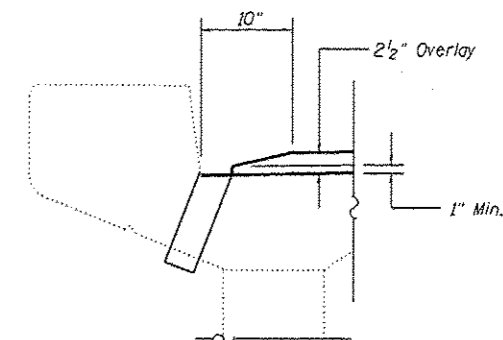
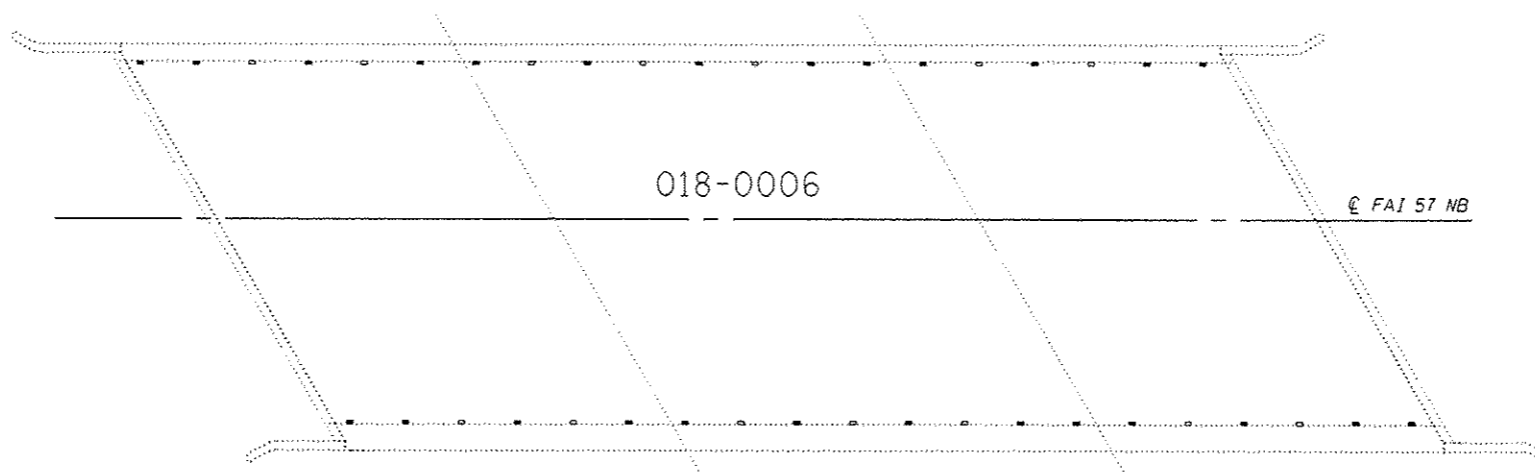

**DRAIN DETAIL  
CROSS SECTION**

Plug drain with concrete

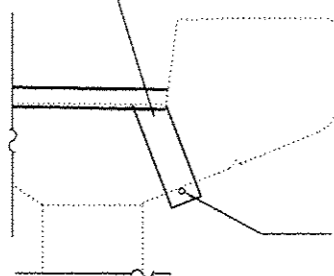

Field drill 3/8" hole for 1/4" threaded rod 13" long with nuts and washers

- Deck Drain to Remain Open
- Deck Drain to be Plugged

**PLUG EXISTING DECK DRAINS DETAIL**

**PLUG EXISTING DECK DRAINS**

SN 018-0005 (SB)	EACH	26
SN 018-0006 (NB)	EACH	26
TOTAL	EACH	52

FILE NAME =	USER NAME = hrtzalk	DESIGNED - JKS	REVISED -	<b>STATE OF ILLINOIS DEPARTMENT OF TRANSPORTATION</b>	<b>PLUG EXISTING DECK DRAINS</b>		F.A.I. R/E.	SECTION	COUNTY	TOTAL SHEETS	SHEET NO.
\\pwwork\pwwork\hrtzalk\080368694\071647-structures-018000506.dgn	DRAWN - 01/16/2014	REVISED -			57	D7 BRIDGE REPAIR 2015-3	CUMBERLAND	30	22		
PLOT SCALE = 40,0000 1/2 in.	CHECKED - MEA	REVISED -			CONTRACT NO. 74647			ILLINOIS FED. AID PROJECT			
Defaults	PLOT DATE = 12/4/2014	DATE - 1/24/2014	REVISED -		SCALE: N/A	SHEET 5 OF 13 SHEETS	STA. TO STA.				



**BEAM REACTIONS**

RP	(K)	17.5
R <sub>L</sub>	(K)	29.7
Imp.	(K)	8.9
R (Total)	(K)	56.1

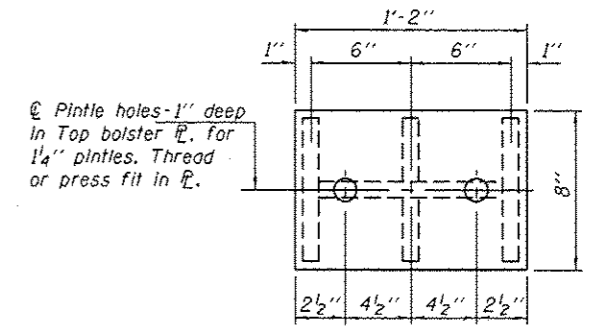

**PLAN TOP PLATE**

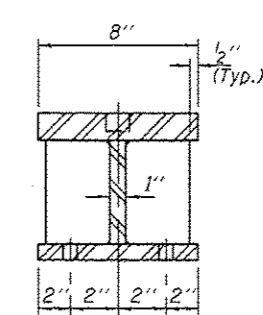

**SECTION B-B**

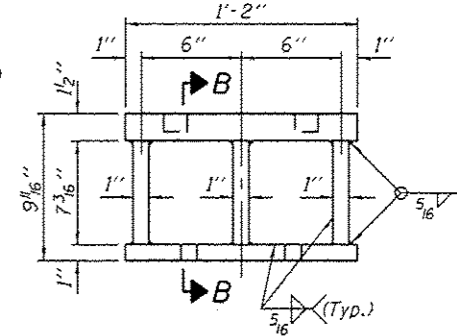

**STEEL EXTENSION DETAIL**

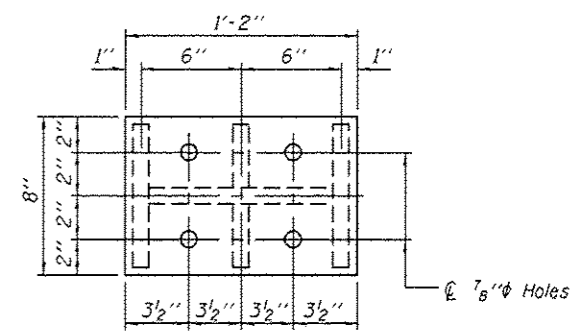

**PLAN BOTTOM PLATE**

Notes:  
 Diaphragm removal and reinstallation may be required to facilitate drilling holes. Cost included with Furnishing and Erecting Structural Steel.  
 New steel extensions, shim plates and connection bolts are included with Furnishing and Erecting Structural Steel.  
 Prior to ordering any material, the Contractor shall verify in the field all bearing height and shim thickness dimensions. Min. Jack capacity = 30 Tons.  
 Anchor bolts shall be ASTM F1554 all-thread for an Engineer-approved alternate material) of the grade(s) and diameter(s) specified. ASTM A307 Grade C anchor bolts may be used in lieu of ASTM F1554 Grade 36 (Fy=36ksi). The corresponding specified grade of AASHTO M314 anchor bolts may be used in lieu of ASTM F1554.  
 Drilled and set anchor bolts shall be installed according to Article 521.06 of the Standard Specifications.  
 Side retainers shall be included in the cost of Elastomeric Bearing Assembly, Type I.

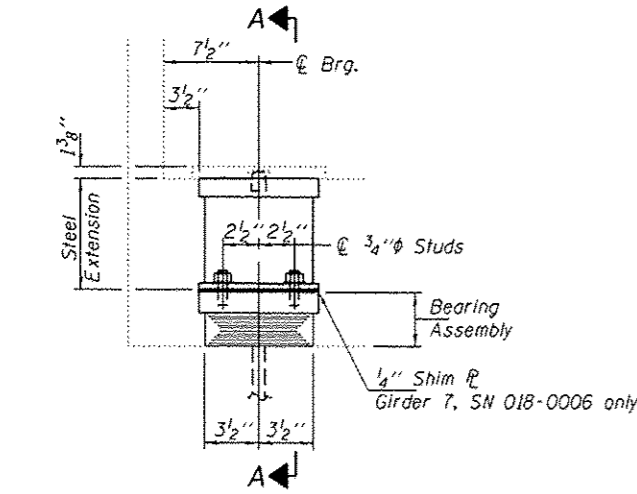

**ELEVATION AT SOUTH ABUTMENT**

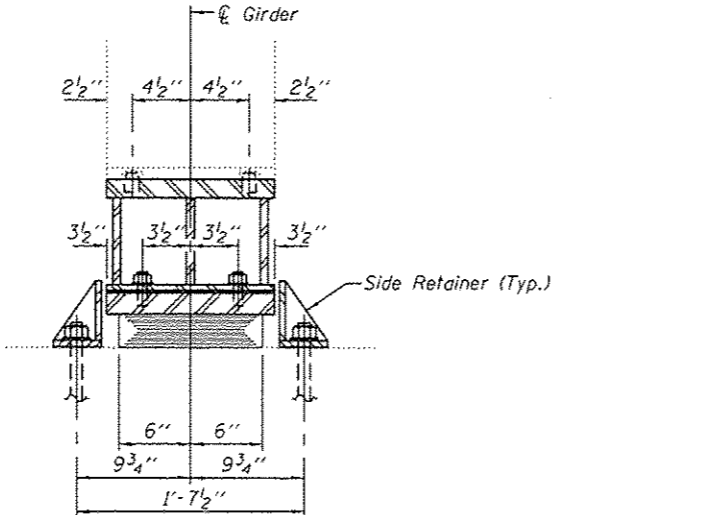

**SECTION A-A**

**TYPE I ELASTOMERIC EXP. BRG.**

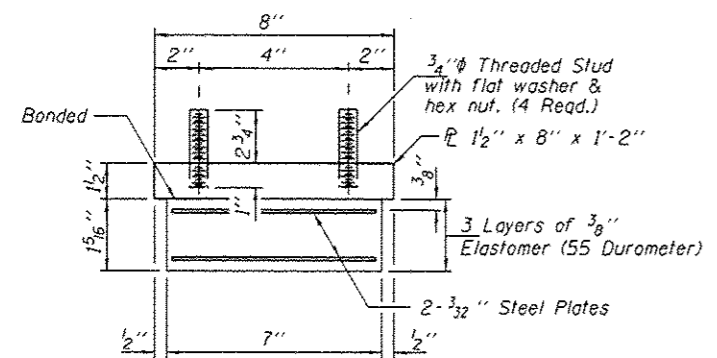

**BEARING ASSEMBLY**

Note:  
 Shim plates shall not be placed under Bearing Assembly.

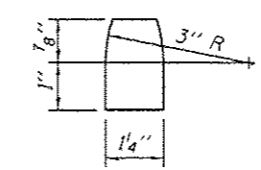

**PINTLE**

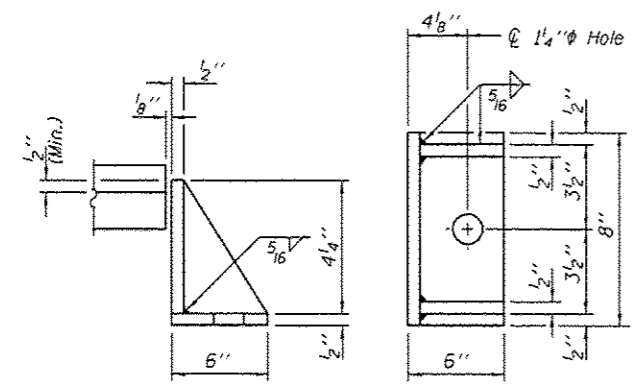

**SIDE RETAINER**

Equivalent rolled angle with stiffeners will be allowed in lieu of welded plates.

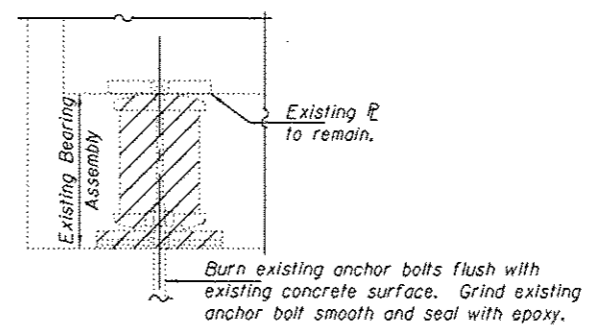

**EXISTING BEARING REMOVAL DETAIL**

Cost Included with Jack and Remove Existing Bearings.

**BILL OF MATERIAL SN 018-0005**

Item	Unit	Total
Elastomeric Bearing Assembly, Type I	Each	7
Jack and Remove Existing Bearings	Each	7
Furnishing and Erecting Structural Steel	Pound	1010
Anchor Bolts 1"φ	Each	14

**BILL OF MATERIAL SN 018-0006**

Item	Unit	Total
Elastomeric Bearing Assembly, Type I	Each	7
Jack and Remove Existing Bearings	Each	7
Furnishing and Erecting Structural Steel	Pound	1020
Anchor Bolts 1"φ	Each	14



**BEAM REACTIONS**

R <sub>Q</sub>	(K)	17.5
R <sub>L</sub>	(K)	29.7
Imp.	(K)	8.9
R (Total)	(K)	56.1

**Notes:**

Diaphragm removal and reinstallation may be required to facilitate drilling holes. Cost included with Furnishing and Erecting Structural Steel.

New steel extensions, shim plates and connection bolts are included with Furnishing and Erecting Structural Steel.

Prior to ordering any material, the Contractor shall verify in the field all bearing height and shim thickness dimensions. Min. jack capacity = 30 Tons.

Anchor bolts shall be ASTM F1554 all-thread (or an Engineer-approved alternate material) of the grade(s) and diameter(s) specified. ASTM A307 Grade C anchor bolts may be used in lieu of ASTM F1554 Grade 36 (F<sub>y</sub>=36ksi).

The corresponding specified grade of AASHTO M314 anchor bolts may be used in lieu of ASTM F1554.

Anchor bolts for Type II bearings shall be placed in holes drilled through the bottom bearing plate after members are in place. Side retainers shall be placed after bolts are installed. Drilled and set anchor bolts shall be installed according to Article 521.06 of the Standard Specifications.

Side retainers shall be included in the cost of Elastomeric Bearing Assembly, Type II.

The 1/8" PTFE sheet shall be bonded directly to the top steel plate with a two-component, medium viscosity epoxy resin, conforming to the requirements of the Federal Specification MMM-A-134, Type I. The bond agent shall be applied on the full area of the contact surfaces.

Bonding of 1/8" PTFE sheet during vulcanizing process will be permitted provided the process and method of adjusting assembly height is approved by the Engineer.

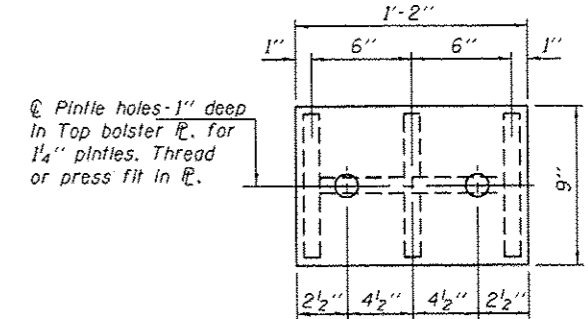

**PLAN TOP PLATE**

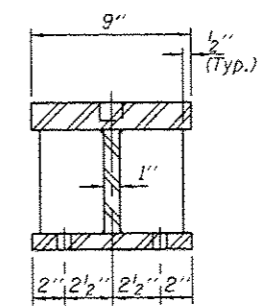

**SECTION B-B**

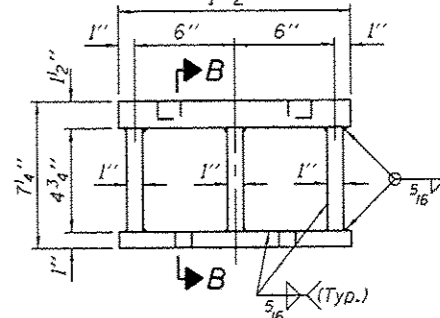

**STEEL EXTENSION DETAIL**

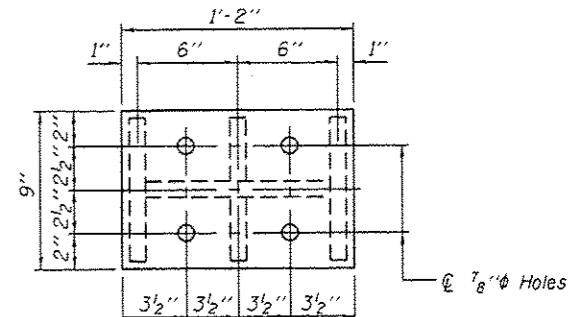

**PLAN BOTTOM PLATE**

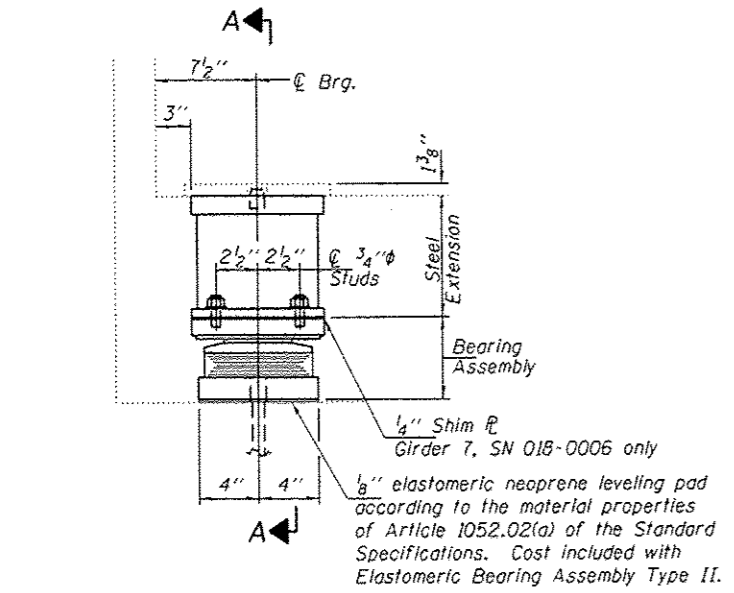

**ELEVATION AT NORTH ABUTMENT**

**TYPE II TFE ELASTOMERIC EXP. BRG.**

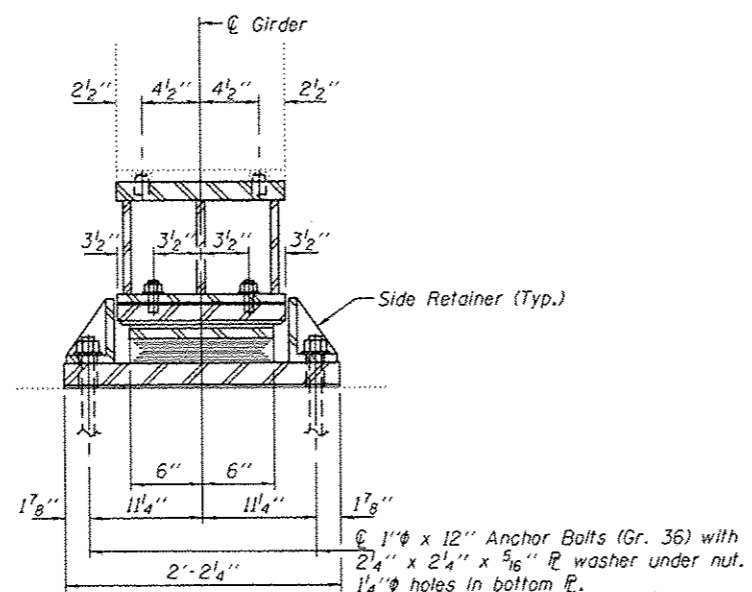

**SECTION A-A**

Notes:  
Diaphragm removal and reinstallation may be required to facilitate drilling holes. Cost included with Furnishing and Erecting Structural Steel.  
New steel extensions, shim plates and connection bolts are included with Furnishing and Erecting Structural Steel.  
Prior to ordering any material, the Contractor shall verify in the field all bearing height and shim thickness dimensions. Min. jack capacity = 30 Tons.  
Anchor bolts shall be ASTM F1554 all-thread (or an Engineer-approved alternate material) of the grade(s) and diameter(s) specified. ASTM A307 Grade C anchor bolts may be used in lieu of ASTM F1554 Grade 36 (F<sub>y</sub>=36ksi).  
The corresponding specified grade of AASHTO M314 anchor bolts may be used in lieu of ASTM F1554.  
Anchor bolts for Type II bearings shall be placed in holes drilled through the bottom bearing plate after members are in place. Side retainers shall be placed after bolts are installed. Drilled and set anchor bolts shall be installed according to Article 521.06 of the Standard Specifications.  
Side retainers shall be included in the cost of Elastomeric Bearing Assembly, Type II.  
The 1/8" PTFE sheet shall be bonded directly to the top steel plate with a two-component, medium viscosity epoxy resin, conforming to the requirements of the Federal Specification MMM-A-134, Type I. The bond agent shall be applied on the full area of the contact surfaces.  
Bonding of 1/8" PTFE sheet during vulcanizing process will be permitted provided the process and method of adjusting assembly height is approved by the Engineer.

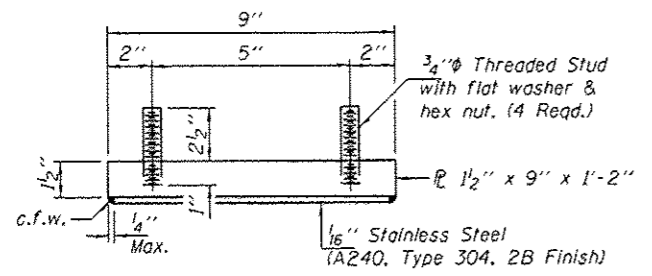

**TOP BEARING ASSEMBLY**

(Looking North)

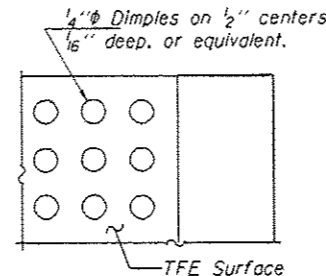

**PLAN-TFE SURFACE**

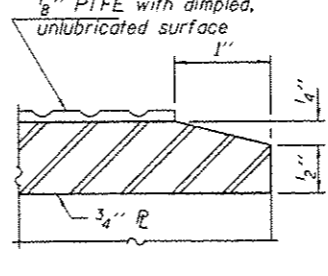

**SECTION THRU TFE**

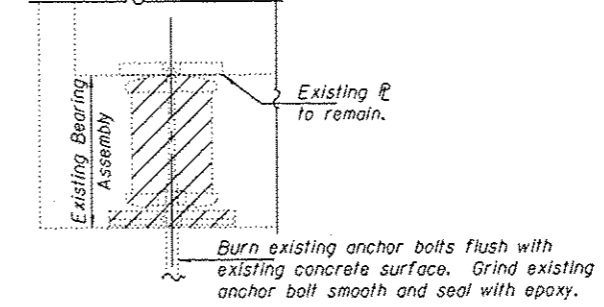

**EXISTING BEARING REMOVAL DETAIL**

Cost included with Jack and Remove Existing Bearings.

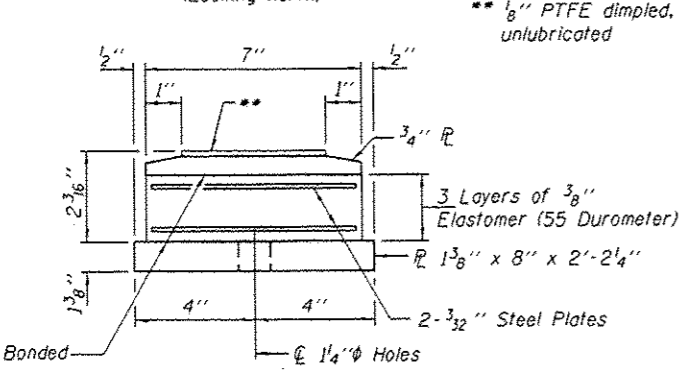

**BOTTOM BEARING ASSEMBLY**

\*\* 1/8" PTFE dimpled, unlubricated

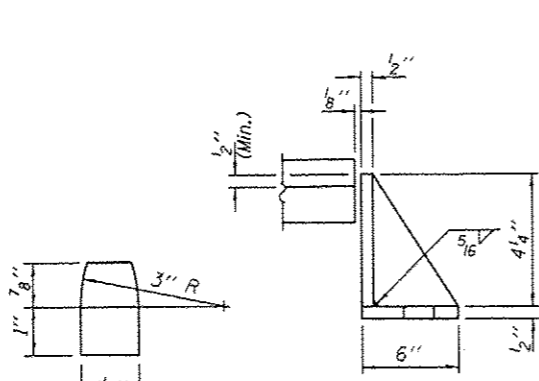

**PINTLE**

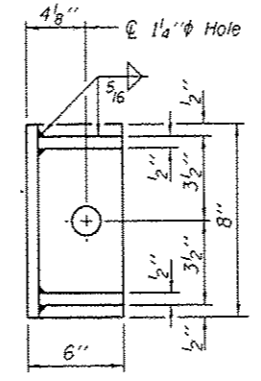

**SIDE RETAINER**

Equivalent rolled angle with stiffeners will be allowed in lieu of welded plates.

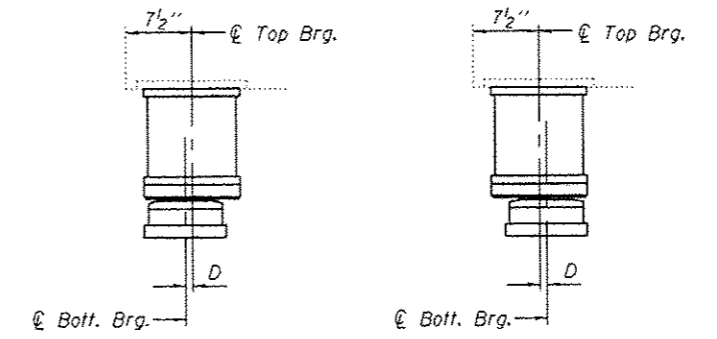

**SETTING ANCHOR BOLTS AT EXP. BRG.**

BELOW 50° F. (Move bott. brg. away from fixed brg.) ABOVE 50° F. (Move bott. brg. toward fixed brg.)

D = 1/8" per each 100' of expansion for every 15° temp. change from the normal temp. of 50°F.

**BILL OF MATERIAL SN 018-0005**

Item	Unit	Total
Elastomeric Bearing Assembly Type II	Each	7
Jack and Remove Existing Bearings	Each	7
Furnishing and Erecting Structural Steel	Pound	960
Anchor Bolts 1"φ	Each	14

**BILL OF MATERIAL SN 018-0006**

Item	Unit	Total
Elastomeric Bearing Assembly Type II	Each	7
Jack and Remove Existing Bearings	Each	7
Furnishing and Erecting Structural Steel	Pound	970
Anchor Bolts 1"φ	Each	14

TYII/REPS 12-03-2008

DESIGNED <b>DAB</b>	EXAMINED <b>Timothy A. Ault</b>	DATE <b>DECEMBER 8, 2014</b>
CHECKED <b>VHV</b>	ACTING ENGINEER OF STRUCTURAL SERVICES	
DRAWN <b>baliva</b>	PASSED <b>Carl Perry</b>	REVISED
CHECKED <b>DAB VHV</b>	ACTING ENGINEER OF BRIDGES AND STRUCTURES	REVISED

**STATE OF ILLINOIS  
DEPARTMENT OF TRANSPORTATION**

**N. ABUTMENT BEARING REPLACEMENT DETAILS  
SN 018-0005 & 0006**

SHEET NO. 8 OF 13 SHEETS

F.A.I. RTE.	SECTION	COUNTY	TOTAL SHEETS	SHEET NO.
57	DT BRIDGE REPAIRS 2015-3	CUMBERLAND	30	25
CONTRACT NO. 74647			ILLINOIS FED. AID PROJECT	

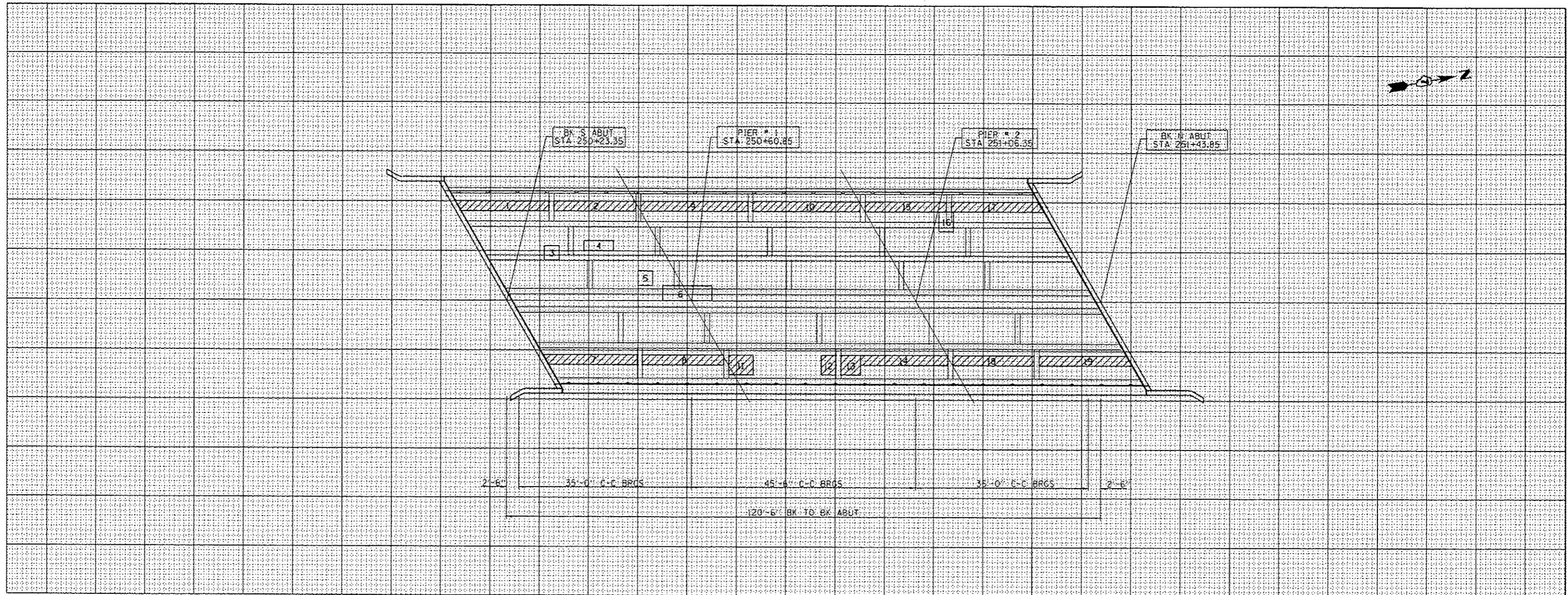

PATCH NO.	SIZE	DECK SLAB REPAIR (PART DEPTH)		
		SO YD	DECK SLAB REPAIR (FD TY 1)	DECK SLAB REPAIR (FD TY 2)
1	2.0 x 18.4			36.8
2	2.0 x 16.6			33.2
3	3.0 x 3.0	9.0		
4	2.0 x 6.0	12.0		
5	3.0 x 3.0	9.0		
6	3.0 x 10.0	30.0		
7	2.0 x 18.5			37.0
8	2.0 x 16.5			33.0
9	2.0 x 21.8			43.5
10	2.0 x 21.8			43.5
11	4.0 x 5.0			20.0
12	4.0 x 3.0			12.0
13	4.0 x 4.0			16.0
14	2.0 x 17.8			35.5
15	2.0 x 16.5			33.0
16	4.0 x 3.0	12.0		
17	2.0 x 18.2			36.4
18	2.0 x 16.5			33.0

PATCH NO.	SIZE	DECK SLAB REPAIR (PART DEPTH)		
		SO YD	DECK SLAB REPAIR (FD TY 1)	DECK SLAB REPAIR (FD TY 2)
19	2.0 x 18.3			36.5
	TOTAL	72	0	449
	PARTIAL DEPTH			
	72 / 9 =	8.0		
	USE	8	50 YD	
	FULL DEPTH, TYPE 1			
	0 / 9 =	0.0		
	USE	0	50 YD	
	FULL DEPTH, TYPE 2			
	449 / 9 =	49.9		
	USE	50	50 YD	

PATCH NO.	SIZE	DECK SLAB REPAIR (PART DEPTH)		
		SO YD	DECK SLAB REPAIR (FD TY 1)	DECK SLAB REPAIR (FD TY 2)

PATCH NO.	SIZE	DECK SLAB REPAIR (PART DEPTH)		
		SO YD	DECK SLAB REPAIR (FD TY 1)	DECK SLAB REPAIR (FD TY 2)

PATCH NO.	SIZE	DECK SLAB REPAIR (PART DEPTH)		
		SO YD	DECK SLAB REPAIR (FD TY 1)	DECK SLAB REPAIR (FD TY 2)

THE LOCATIONS AND SIZES SHOWN GRAPHICALLY ABOVE ARE APPROXIMATE. SEE THIS TABLE FOR ACTUAL SIZES.

**PATCHING LEGEND**

PARTIAL DEPTH (FOR INFORMATION ONLY)

FULL DEPTH

DATE OF SURVEY: 11/26/2013  
SURVEY BY: MEA, JKS  
METHOD OF SURVEY: VISUAL

005

FILE NAME : c:\pwworkspace\pwworkspace\120368644\077447-structure\120368644\077447.dwg  
USER NAME : jkzskl  
DESIGNED - JKS  
DRAWN - 01/16/2014  
CHECKED - MEA  
PLOT DATE - 12/4/2014  
REVISED -  
REVISED -  
REVISED -

STATE OF ILLINOIS  
DEPARTMENT OF TRANSPORTATION

BRIDGE DECK PATCHING  
S.N. 018-0005 (SB)

SCALE: N/A  
SHEET NO. 9 OF 13 SHEETS  
STA. TO STA.

F.A.I. RTE.	SECTION	COUNTY	TOTAL SHEETS	SHEET NO.
57	07 BRIDGE REPAIRS 2015-3	CUMBERLAND	30	26

CONTRACT NO. 74647  
ILLINOIS FED. AID PROJECT





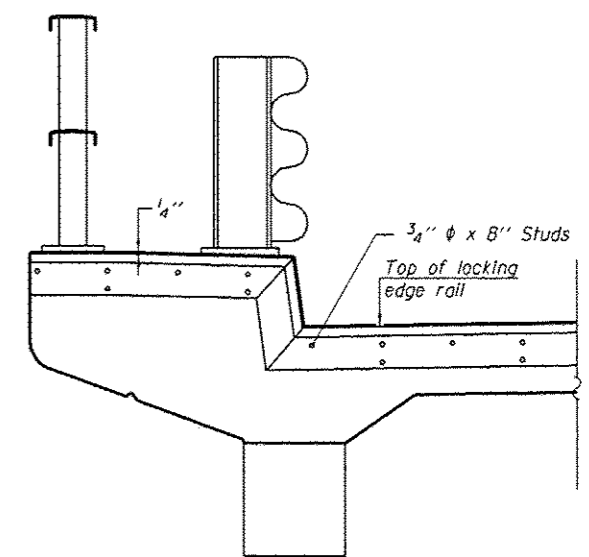
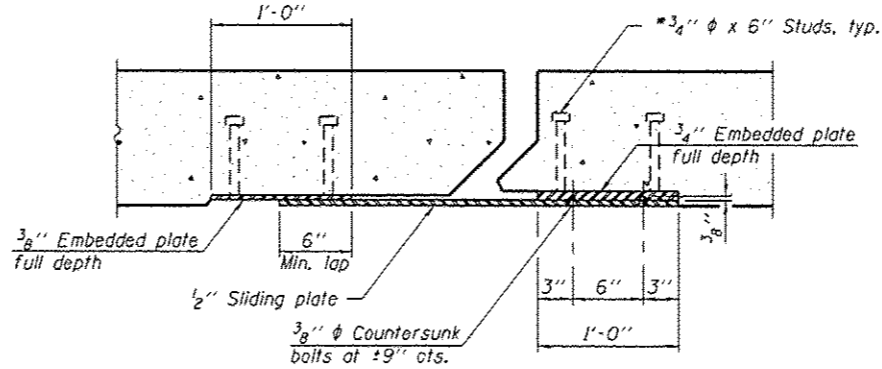
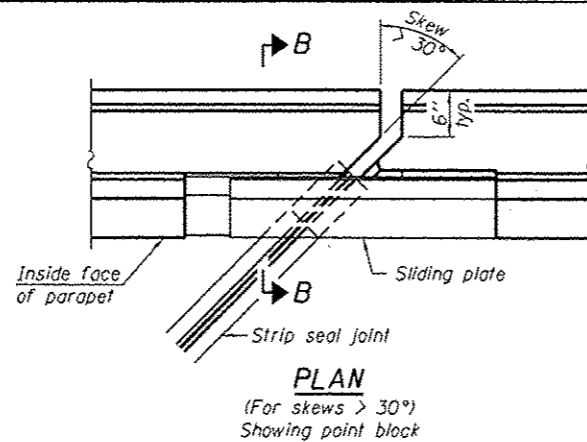
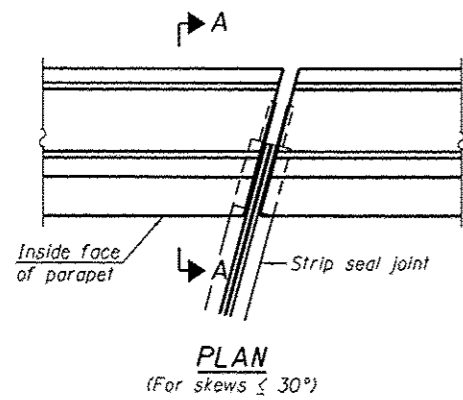

TYPICAL END TREATMENT AT CURB

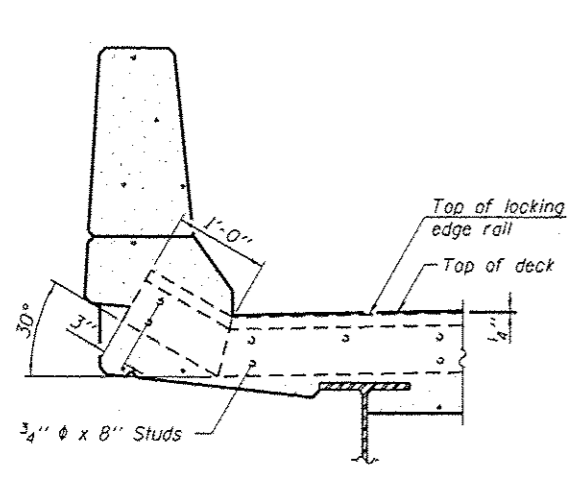

SECTION A-A

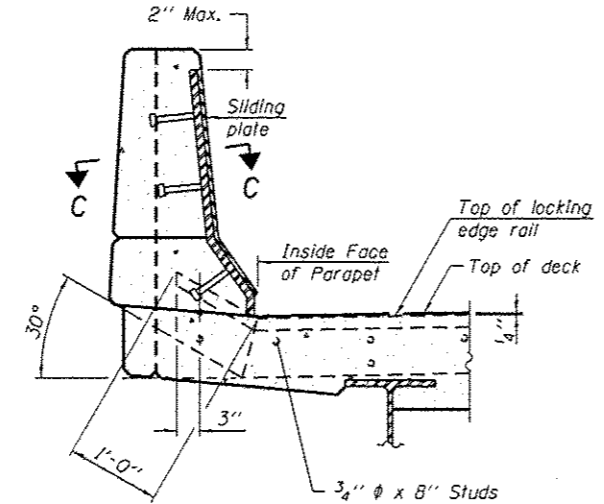

SECTION B-B

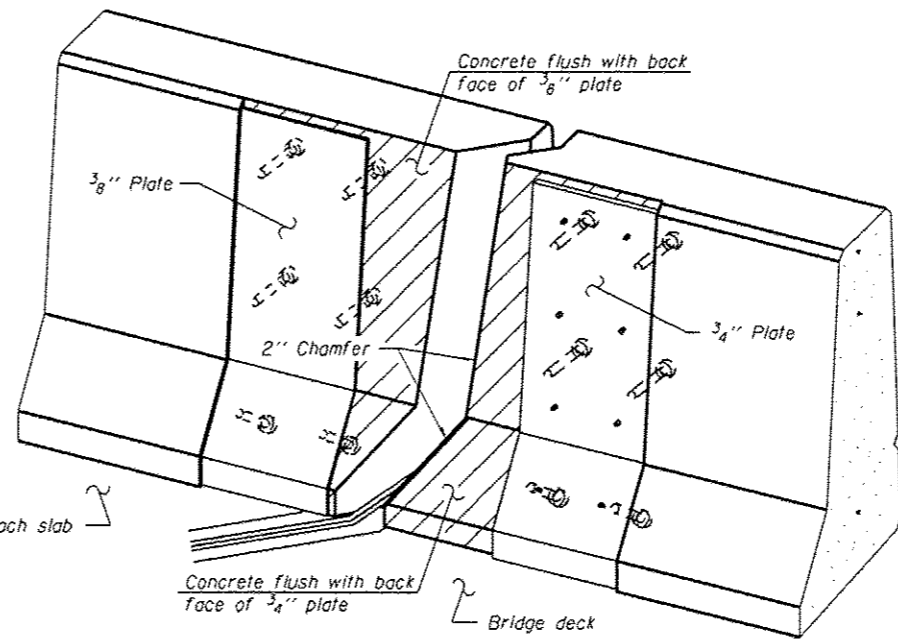

TRIMETRIC VIEW (Showing back plates only)

Notes:  
The strip seal shall be made continuous and shall have a minimum thickness of 1/4 inch. The configuration of the strip seal shall match the configuration of the Locking Edge Rails. Open or "webbed" strip seal gland configurations are not permitted. The gland shall be sized for a maximum rated movement of 4 inches.

The Locking Edge Rails depicted are conceptual only, except for the minimum dimensions shown. The actual configuration of the Locking Edge Rails and matching strip seal may vary from manufacturer to manufacturer. Flanged edge rails will not be allowed. Locking Edge Rails may be spliced at slope discontinuities.

The manufacturer's recommended installation methods shall be followed.  
The joint opening and deck dimensions detailed on the superstructure are based on a rolled rail expansion joint. If the Contractor elects to use the welded rail expansion joint, the opening and deck dimensions shall be modified according to the dimensions detailed on this sheet. Required modifications shall be made at no additional cost to the State.

All steel components shall be galvanized after fabrication according to Article 520.03 of the Standard Specifications. Maximum space between rail segments shall be 3/16 inch, sealed with a suitable sealant. Joints in rails within 10 ft. of curbs shall be welded.

Parapet plates and anchorage studs for skews > 30 degrees included in the cost of Preformed Joint Strip Seal.

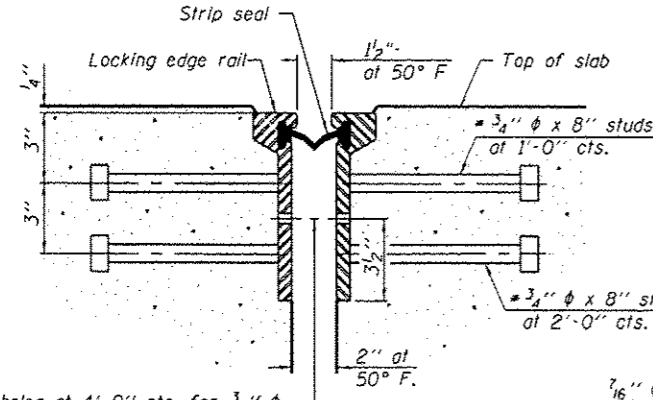

SECTION THRU ROLLED RAIL JOINT

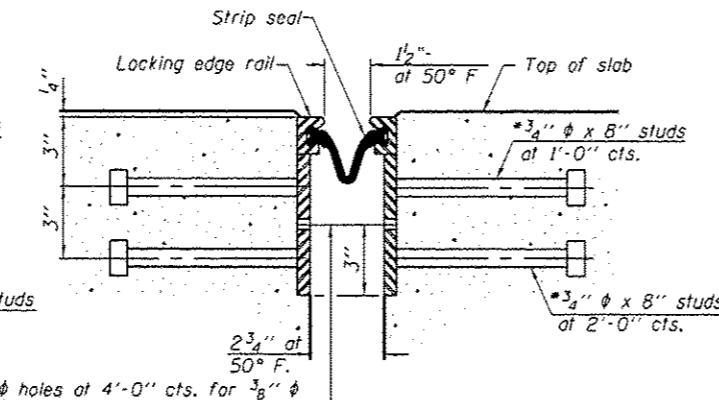

SECTION THRU WELDED RAIL JOINT

\* Granular or solid flux filled headed studs conforming to Article 1006.32 of the Std. Specs., automatically end welded.

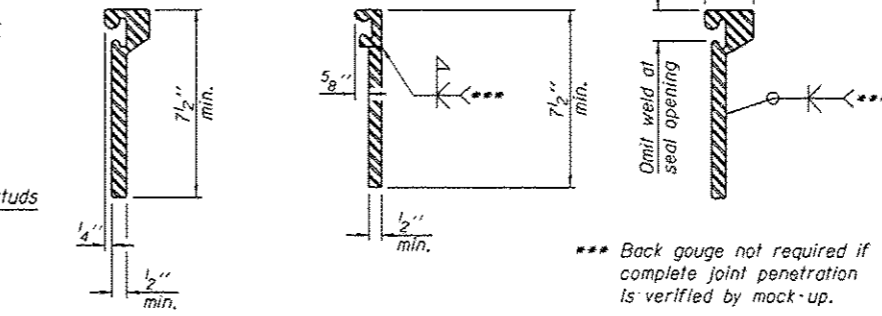

ROLED EXTRUDED RAIL WELDED RAIL

LOCKING EDGE RAIL SPLICE

The inside of the locking edge rail groove shall be free of weld residue. Rolled rail shown, welded rail similar.

LOCKING EDGE RAILS

BILL OF MATERIAL

Item	Unit	Total
Preformed Joint Strip Seal	Foot	208.0

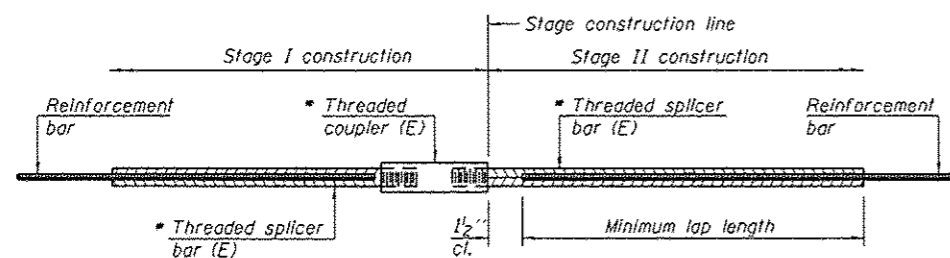

**STANDARD BAR SPLICER ASSEMBLY**

Minimum Lap Lengths						
Bar size to be spliced	Table 1	Table 2	Table 3	Table 4	Table 5	Table 6
3, 4	1'-5"	1'-11"	2'-1"	2'-4"	2'-7"	2'-11"
5	1'-9"	2'-5"	2'-7"	2'-11"	3'-3"	3'-8"
6	2'-1"	2'-11"	3'-1"	3'-6"	3'-10"	4'-5"
7	2'-9"	3'-10"	4'-2"	4'-8"	5'-2"	5'-10"
8	3'-8"	5'-1"	5'-5"	6'-2"	6'-9"	7'-8"
9	4'-7"	6'-5"	6'-10"	7'-9"	8'-7"	9'-8"

- Table 1: Black bar, 0.8 Class C
- Table 2: Black bar, Top bar lap, 0.8 Class C
- Table 3: Epoxy bar, 0.8 Class C
- Table 4: Epoxy bar, Top bar lap, 0.8 Class C
- Table 5: Epoxy bar, Class C
- Table 6: Epoxy bar, Top bar top, Class C

Threaded splicer bar length = min. lap length + 1/2" + thread length

\* Epoxy not required on Bar Splicer Assembly components used in conjunction with black bars.

Location	Bar size	No. assemblies required	Table for minimum lap length
018-0005 (SB)	#5	22	Table 3
018-0005 (NB)	#6	8	Table 3
018-0006 (NB)	#5	22	Table 3
018-0006 (NB)	#6	8	Table 3

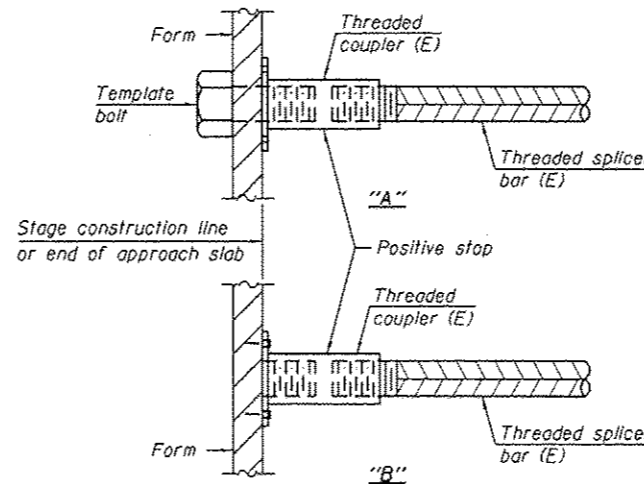

**INSTALLATION AND SETTING METHODS**

"A": Set bar splicer assembly by means of a template bolt.  
 "B": Set bar splicer assembly by nailing to wood forms or cementing to steel forms.  
 (E): Indicates epoxy coating.

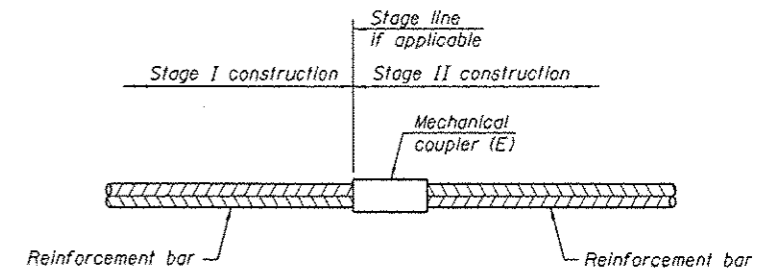

**STANDARD MECHANICAL SPLICER**

Location	Bar size	No. assemblies required

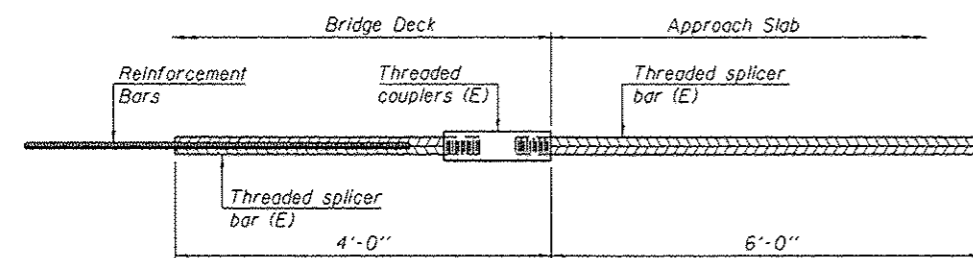

**BAR SPLICER ASSEMBLY FOR #5 BAR ON INTEGRAL OR SEMI-INTEGRAL ABUTMENTS**

No. required =

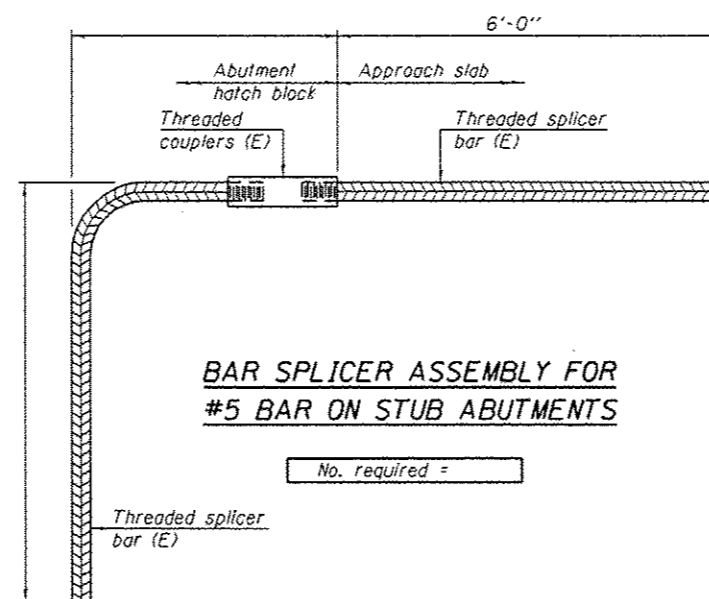

**BAR SPLICER ASSEMBLY FOR #5 BAR ON STUB ABUTMENTS**

No. required =

**NOTES**

Splicer bars shall be deformed with threaded ends and have a minimum 60 ksi yield strength.  
 All reinforcement shall be lapped and tied to the splicer bars.  
 Bar splicer assemblies shall be epoxy coated according to the requirements for reinforcement bars. See Section 508 of the Standard Specifications.  
 See approved list of bar splicer assemblies and mechanical splicers for alternatives.

BSD-1

1-27-12

FILE NAME =	USER NAME = hrszsk1	DESIGNED - JKS	REVISED -	<b>STATE OF ILLINOIS DEPARTMENT OF TRANSPORTATION</b>	<b>BAR SPLICER ASSEMBLY AND MECHANICAL SPLICER DETAILS</b> S.N. 018-0005 (SB) & 018-0006 (NB)	F.A.I. RTE.	SECTION	COUNTY	TOTAL SHEETS	SHEET NO.	
c:\pwworking\hrs\sk1\0308094\07	647-structures-01800506.dgn	DRAWN - 01/16/2014	REVISED -			57	07 BRIDGE REPAIR 2015-3	CUMBERLAND	30	29	
Default	PLOT SCALE = 40.0000 / in.	CHECKED - MEA	REVISED -			CONTRACT NO. 74647					
	PLOT DATE = 12/4/2014	DATE - 1/24/2014	REVISED -			[ILLINOIS] FED. AID PROJECT					

When "A" is 3'-6" or less, the temporary concrete barrier shall be anchored to the new slab according to Detail I or Detail II. No anchorage is required when "A" is greater than 3'-6".

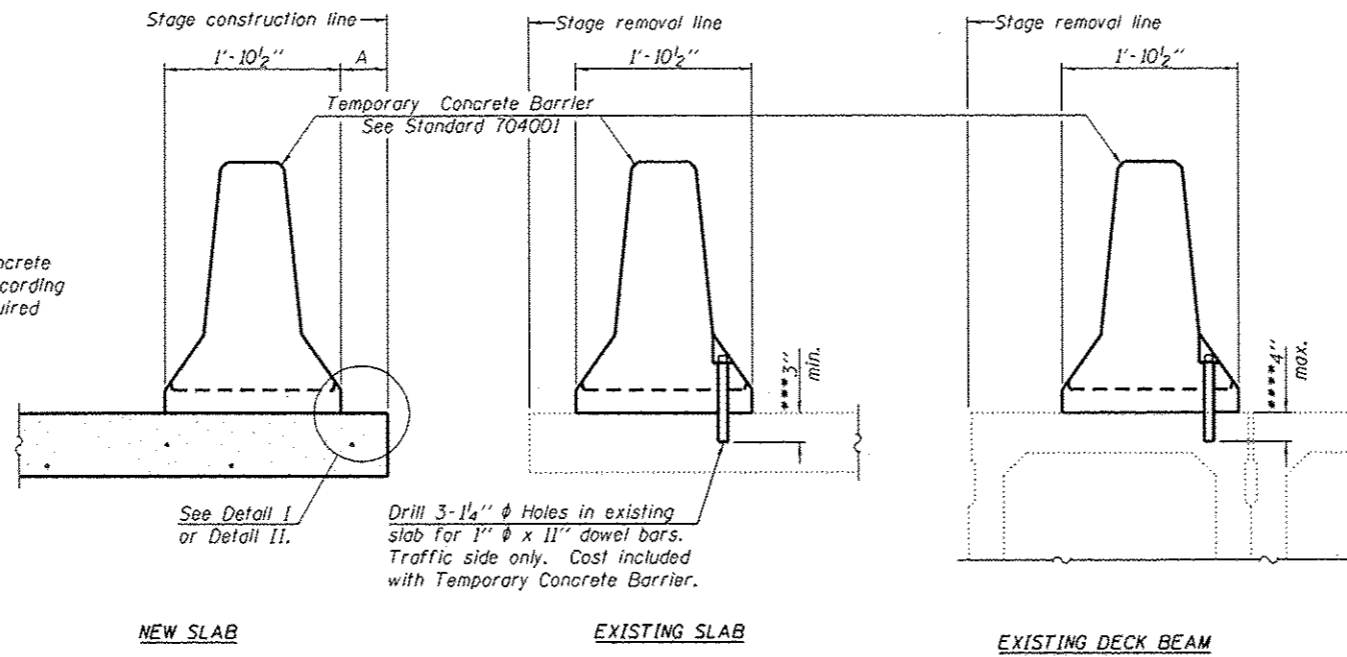

**SECTIONS THRU SLAB OR DECK BEAM**

**NOTES**

Detail I - With Bar Splicer or Couplers:  
Connect one (1) 1" x 7" x "W" steel  $\bar{L}$  to the top layer of couplers with 2-5/8"  $\phi$  bolts screwed to coupler at approximate  $\bar{C}$  of each barrier panel.

Detail II - With Extended Reinforcement Bars:  
Connect one (1) 1" x 7" x "W" steel  $\bar{L}$  to the concrete slab or concrete wearing surface with 2-5/8"  $\phi$  Expansion Anchors or cast in place inserts spaced between the top layer of reinforcement at approximate  $\bar{C}$  of each barrier panel.

Cost of anchorage is included with Temporary Concrete Barrier. The 1" x 7" x "W" plate shall not be removed until stage II construction forms and all reinforcement bars are in place and the concrete is ready to be placed.

\*\*\* Dimension shown is minimum required embedment into concrete. If hot-mix asphalt wearing surface is present, minimum embedment shall be in addition to wearing surface depth.

\*\*\*\* If existing deck beam is to remain in place after stage construction, embedment shall only be into wearing surface and not into existing deck beam concrete.

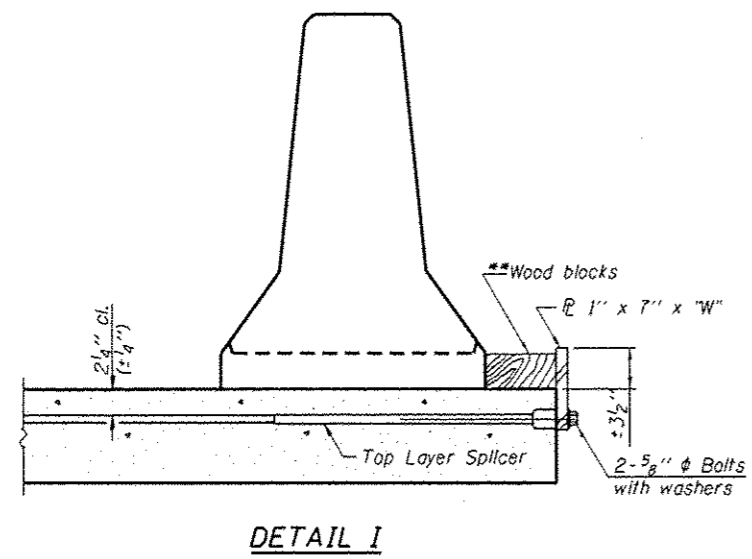

**DETAIL I**

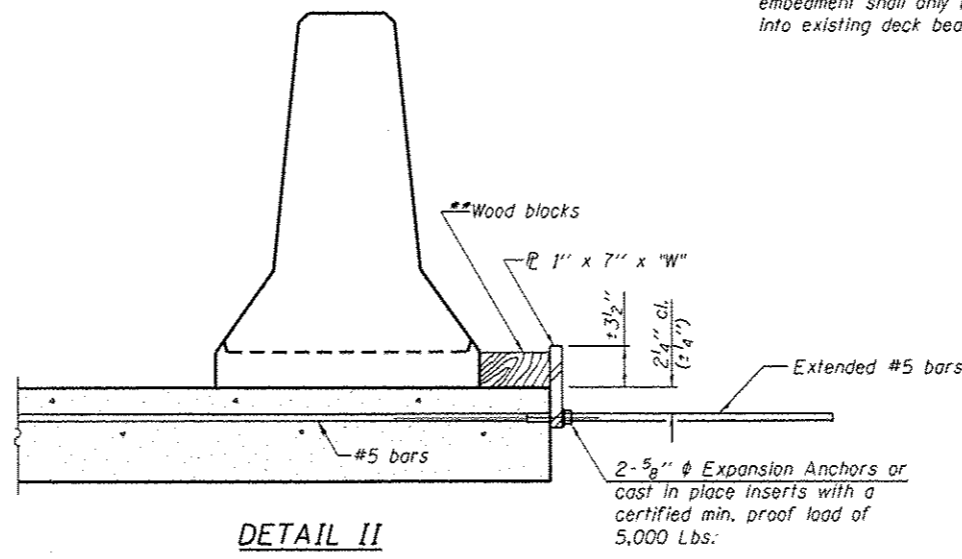

**DETAIL II**

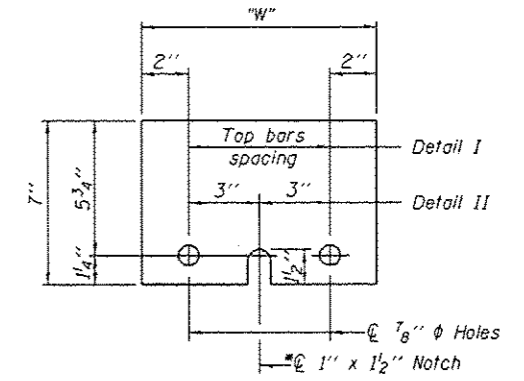

**STEEL RETAINER  $\bar{L}$  1" x 7" x "W"**  
\* Required only with Detail II

\*\* Wood blocks may be omitted when required to provide minimum stage traffic lane width. When the wood blocks are omitted, the concrete barrier shall be in direct contact with the steel retainer plate.

"W" = Top bars spacing + 4"

R-27

7-1-10

FILE NAME : c:\p\work\p\idat\h\stae\k\00368691\07	USER NAME : h\stae\k	DESIGNED - JKS	REVISED -	<b>STATE OF ILLINOIS DEPARTMENT OF TRANSPORTATION</b>	<b>TEMPORARY CONCRETE BARRIER FOR STAGE CONSTRUCTION</b>		F.A.I. RTE.	SECTION	COUNTY	TOTAL SHEETS	SHEET NO.
	4647-structura-D18000506.dgn	DRAWN - 01/16/2014	REVISED -		<b>S.N. 018-0005 (SB) &amp; 018-0006 (NB)</b>		57	07 BRIDGE REPAIR 2015-3	CUMBERLAND	30	30
	PLOT SCALE = 48.0000' / in.	CHECKED - MEA	REVISED -		SCALE: N/A	SHEET 13 OF 13 SHEETS	STA.	TO STA.		CONTRACT NO. 74647	
Defaults	PLOT DATE = 12/4/2014	DATE - 1/24/2014	REVISED -		ILLINOIS FED. AID PROJECT						