

STATE OF ILLINOIS
DEPARTMENT OF TRANSPORTATION

| F.A.P. RTE. | SECTION | COUNTY | TOTAL SHEETS | SHEET NO. |
|-------------|------------------------------|--------|--------------------|-----------|
| 877 | D9 BRIDGE DECK REPAIR 2020-1 | WHITE | 12 | 1 |
| ILLINOIS | | | CONTRACT NO. 78724 | |

PROPOSED HIGHWAY PLANS

F.A.P. ROUTE 877 (IL 141)
SECTION D9 BRIDGE DECK REPAIR 2020-1
PROJECT STP-UWAZ(733)
BRIDGE REPAIRS & CONCRETE OVERLAY
WHITE COUNTY

C-99-053-19

D-99-031-19

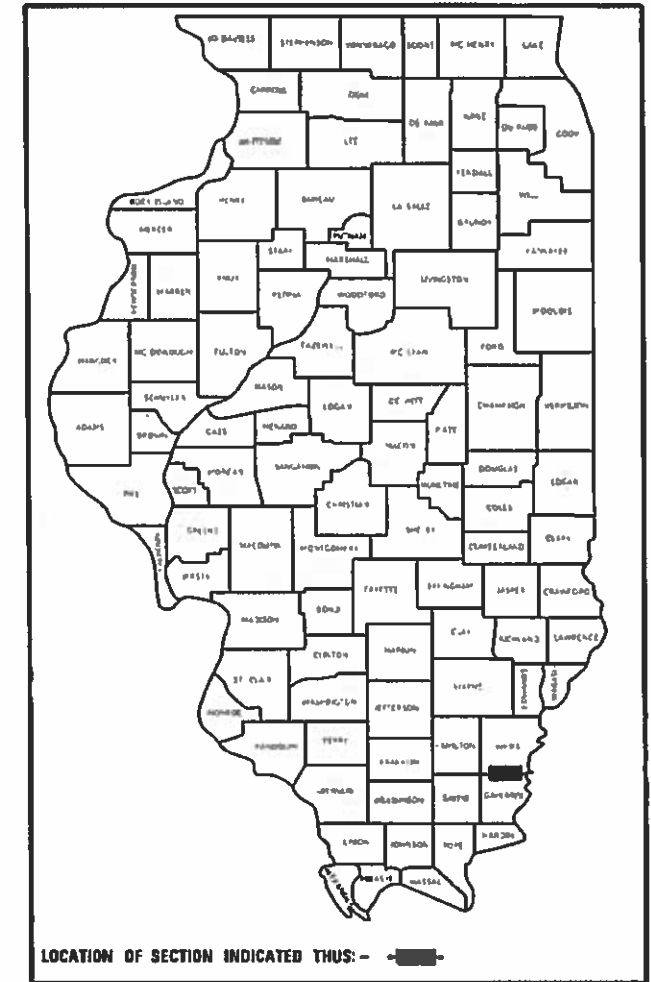

FOR INDEX OF SHEETS, SEE SHEET NO. 3
FOR SUMMARY OF QUANTITIES, SEE SHEET NO. 4-6
FOR STRUCTURAL PAVEMENT DESIGN INFORMATION, SEE SHEET NO. N/A

TRAFFIC DATA

IL 141 TRAFFIC DATA
2017 ADT=2400
14% TRUCKS

TOWNSHIPS

HERALDS PRAIRIE

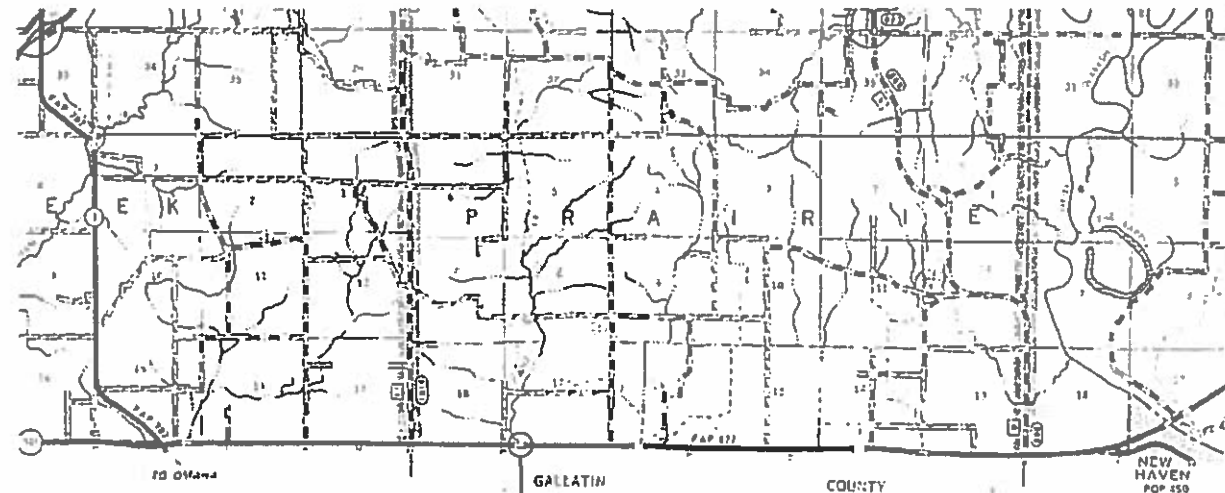

PROJECT LOCATION
SN 097-0067
IL 141 OVER TRIB TO CANE CREEK

DESIGN DESIGNATION : N/A
COORDINATE SYSTEM : ILLINOIS COORDINATE SYSTEM, EAST ZONE
POSTED SPEED : 55 MPH

J.U.L.I.E.
JOINT UTILITY LOCATION INFORMATION FOR EXCAVATION
1-800-892-8123
OR 811

PROJECT ENGINEER: DAVID PICHE
PROJECT DESIGNER: AUSTIN HENK

CONTRACT NO. 78724

GROSS LENGTH = 110 FT. = 0.02 MILE
NET LENGTH = 110 FT. = 0.02 MILE

STATE OF ILLINOIS
DEPARTMENT OF TRANSPORTATION

SUBMITTED 12-04-2019
[Signature]
REGION FIVE ENGINEER
Jan 31, 2020
[Signature]
ENGINEER OF DESIGN AND ENVIRONMENT
Jan 31, 2020
[Signature]
DIRECTOR OF HIGHWAYS PROJECT IMPLEMENTATION

PRINTED BY THE AUTHORITY
OF THE STATE OF ILLINOIS







Model: Default
File Name: \\lantron\dot\illinois\pwr\DOT\Documents\DOT Office\District - 80\Illinois\78724\CD\Drawings\DOT - 78724-Sheets.dwg

| | | |
|------------------------------|-----------------|-----------|
| USER NAME = henkas | DESIGNED - ASH | REVISED - |
| PLOT SCALE = 100.0000' / in. | DRAWN - ASH | REVISED - |
| PLOT DATE = 11/12/19 | CHECKED - MAS | REVISED - |
| | DATE - 11/12/19 | REVISED - |

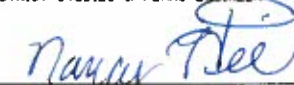
**STATE OF ILLINOIS
DEPARTMENT OF TRANSPORTATION**

| SIGNATURES | | | | |
|------------|-------|----|--------|--------------|
| SCALE: | SHEET | OF | SHEETS | STA. TO STA. |

| F.A.P. RTE. | SECTION | COUNTY | TOTAL SHEETS | SHEET NO. |
|---------------------------|------------------------------|--------|--------------|-----------|
| 877 | DS BRIDGE DECK REPAIR 2020-1 | WHITE | 12 | 2 |
| ILLINOIS FED. AID PROJECT | | | | |

| | |
|--------------|---|
| Prepared By: |  DISTRICT STUDIES & PLANS ENGINEER |
| Examined By: |  DISTRICT LAND ACQUISITION ENGINEER |
| Examined By: |  DISTRICT PROGRAM DEVELOPMENT ENGINEER |
| Examined By: |  DISTRICT OPERATIONS ENGINEER |
| Examined By: |  DISTRICT PROJECT IMPLEMENTATION ENGINEER |
| Examined By: |  DISTRICT CONSTRUCTION ENGINEER |
| Examined By: |  DISTRICT MATERIALS ENGINEER |

SUMMARY OF QUANTITIES - CONT

COUNTY: WHITE
 ROUTE: IL 141
 FUNDING: 80% FED 20% STATE
 LOCATION: RURAL

| CODE NUMBER | ITEM DESCRIPTION | UNIT | STRUCTURE 0013 |
|-------------|---|--------|-------------------|
| 67100100 | MOBILIZATION | L SUM | 1 |
| 70100100 | TRAFFIC CONTROL AND PROTECTION, STANDARD 701316 | EACH | 1 |
| 70100450 | TRAFFIC CONTROL AND PROTECTION, STANDARD 701201 | L SUM | 1 |
| 70100500 | TRAFFIC CONTROL AND PROTECTION, STANDARD 701326 | L SUM | 1 |
| 70106500 | TEMPORARY BRIDGE TRAFFIC SIGNALS | EACH | 1 |
| 70106700 | TEMPORARY RUMBLE STRIPS | EACH | 6 |
| 70107025 | CHANGEABLE MESSAGE SIGN | CAL DA | 28 |
| 70300100 | SHORT TERM PAVEMENT MARKING | FOOT | 100 |
| 70300150 | SHORT TERM PAVEMENT MARKING REMOVAL | SQ FT | 33 |
| * 78001110 | PAINT PAVEMENT MARKING - LINE 4" | FOOT | 370 |
| * 86200300 | UNINTERRUPTABLE POWER SUPPLY, EXTENDED | EACH | 1 |
| X0327979 | PAVEMENT MARKING REMOVAL - GRINDING | SQ FT | 90 |
| Z0012111 | BRIDGE DECK FLY ASH OR GGBF SLAG CONCRETE OVERLAY, 2 1/2" | SQ YD | 387 |

* SPECIALTY ITEM

MODEL: Default
 FILE: \\nas01c.psu.edu\pub\harcam\dat\illinois\pww\DOT\Documents\DOT_Offices\Illin\ct 9\Projects\78724\CADD\Drawings\09_78724-Sheets.dgn

| | | |
|-------------------------------|-----------------|-----------|
| USER NAME = henkas | DESIGNED - ASH | REVISED - |
| PLOT SCALE = 100.0000 ' / in. | DRAWN - ASH | REVISED - |
| PLOT DATE = 12/5/2019 | CHECKED - MAS | REVISED - |
| | DATE - 11/12/19 | REVISED - |

**STATE OF ILLINOIS
DEPARTMENT OF TRANSPORTATION**

SUMMARY OF QUANTITIES

SCALE: SHEET OF SHEETS STA. TO STA.

| F.A.P. RTE. | SECTION | COUNTY | TOTAL SHEETS | SHEET NO. |
|---------------------------|------------------------------|--------|--------------|-----------|
| 877 | 09 BRIDGE DECK REPAIR 2020-1 | WHITE | 12 | 5 |
| CONTRACT NO. 78724 | | | | |
| ILLINOIS FED. AID PROJECT | | | | |

SUMMARY OF QUANTITIES - CONT

| | |
|-----------|-------------------|
| COUNTY: | WHITE |
| ROUTE: | IL 141 |
| FUNDING: | 80% FED 20% STATE |
| LOCATION: | RURAL |
| | STRUCTURE |
| | 0013 |

| CODE NUMBER | ITEM DESCRIPTION | UNIT | STRUCTURE |
|-------------|--------------------------------|-------|-----------|
| Z0012130 | BRIDGE DECK SCARIFICATION 3/4" | SQ YD | 387 |
| Z0041895 | POLYMER CONCRETE | CU FT | 4.0 |
| | | | |

MODEL: Default
 FILE: hmkc_p04uplanroom.dwg
 I:\Projects\78724\CADDData\CAD\hmkc\DOT_78724\78724-Sheets.dgn

| USER NAME = hmkc PLOT SCALE = 100.0000' / in. PLOT DATE = 12/5/2019 | DESIGNED - ASH DRAWN - ASH CHECKED - MAS DATE - 11/12/19 | REVISED - REVISED - REVISED - REVISED - | STATE OF ILLINOIS DEPARTMENT OF TRANSPORTATION | SUMMARY OF QUANTITIES | <table border="1" style="width: 100%; border-collapse: collapse;"> <tr> <th style="width: 10%;">F.A.P. RTE.</th> <th style="width: 40%;">SECTION</th> <th style="width: 10%;">COUNTY</th> <th style="width: 10%;">TOTAL SHEETS</th> <th style="width: 10%;">SHEET NO.</th> </tr> <tr> <td style="text-align: center;">877</td> <td style="text-align: center;">09 BRIDGE DECK REPAIR 2020-1</td> <td style="text-align: center;">WHITE</td> <td style="text-align: center;">12</td> <td style="text-align: center;">6</td> </tr> <tr> <td colspan="5" style="text-align: center;">CONTRACT NO. 78724</td> </tr> </table> | F.A.P. RTE. | SECTION | COUNTY | TOTAL SHEETS | SHEET NO. | 877 | 09 BRIDGE DECK REPAIR 2020-1 | WHITE | 12 | 6 | CONTRACT NO. 78724 | | | | |
|---|---|--|---|-----------------------|--|---------------------------|---------|--------|--------------|-----------|-----|------------------------------|-------|----|---|--------------------|--|--|--|--|
| F.A.P. RTE. | SECTION | COUNTY | TOTAL SHEETS | SHEET NO. | | | | | | | | | | | | | | | | |
| 877 | 09 BRIDGE DECK REPAIR 2020-1 | WHITE | 12 | 6 | | | | | | | | | | | | | | | | |
| CONTRACT NO. 78724 | | | | | | | | | | | | | | | | | | | | |
| | | | SCALE: | SHEET OF SHEETS | STA. TO STA. | ILLINOIS FED. AID PROJECT | | | | | | | | | | | | | | |

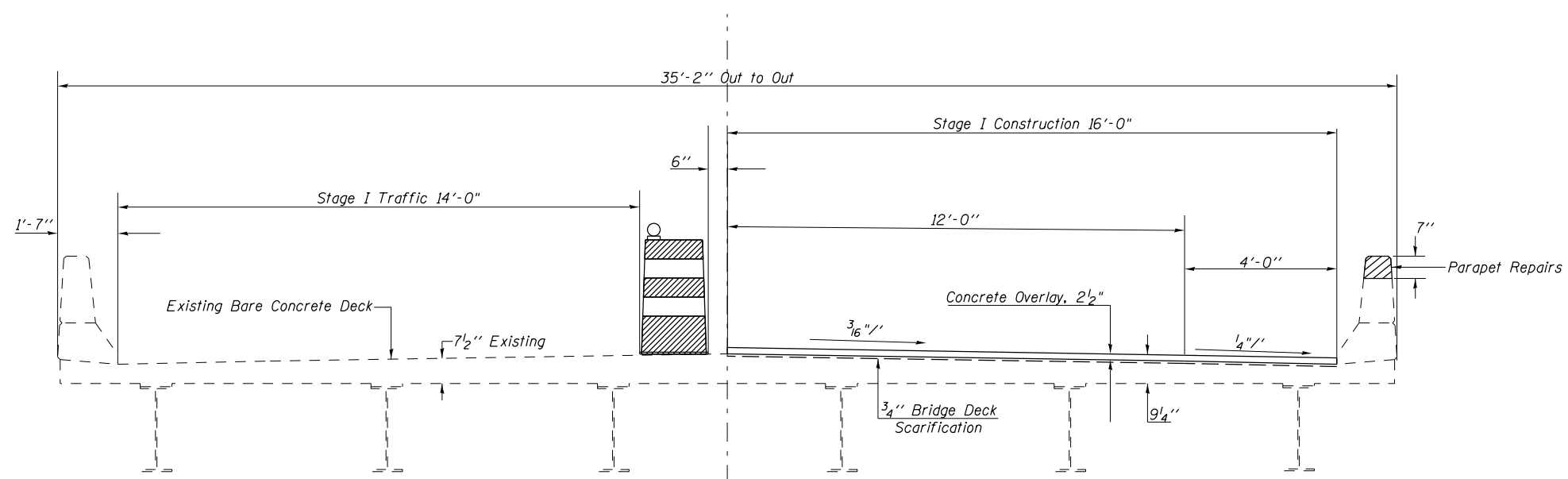

STAGE I TYPICAL SECTION THRU OVERLAY

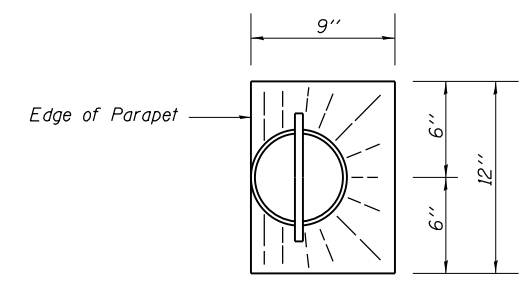

TOP PLAN
Slope Overlay at Drains

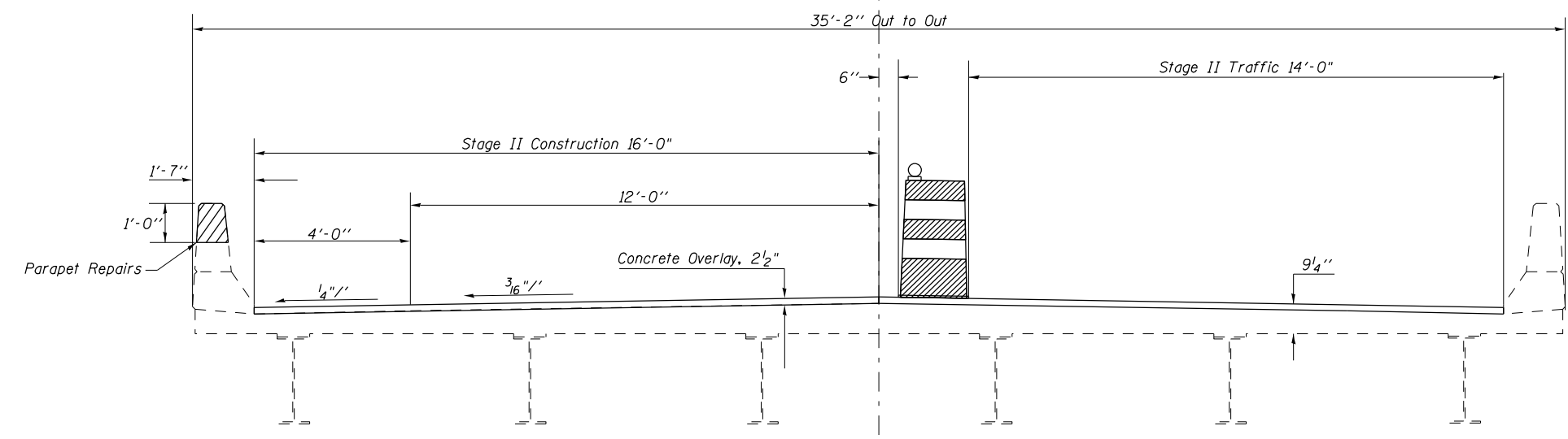

STAGE II TYPICAL SECTION THRU OVERLAY

All sections looking East

**STAGING
TYPICAL SECTION
SN 097-0067
WHITE COUNTY**

MODEL: Default
 FILE: Model: 20190505_10:41:00:RWDOT\Documents\DOT_Offices\District 9\Projects\78724\CADD\Drawings\978724-Sheets.dgn

| | | |
|----------------------------|-----------------|-----------|
| USER NAME = henkas | DESIGNED - ASH | REVISED - |
| | DRAWN - ASH | REVISED - |
| PLOT SCALE = 4.0000' / in. | CHECKED - MAS | REVISED - |
| PLOT DATE = 12/5/2019 | DATE - 11/12/19 | REVISED - |

**STATE OF ILLINOIS
DEPARTMENT OF TRANSPORTATION**

| STAGE CONSTRUCTION DETAILS | | | |
|----------------------------|-------|-----------|--------------|
| SCALE: | SHEET | OF SHEETS | STA. TO STA. |

| F.A.P. RTE. | SECTION | COUNTY | TOTAL SHEETS | SHEET NO. |
|---------------------------|------------------------------|--------|--------------|-----------|
| 877 | D9 BRIDGE DECK REPAIR 2020-1 | WHITE | 12 | 8 |
| CONTRACT NO. 78724 | | | | |
| ILLINOIS FED. AID PROJECT | | | | |

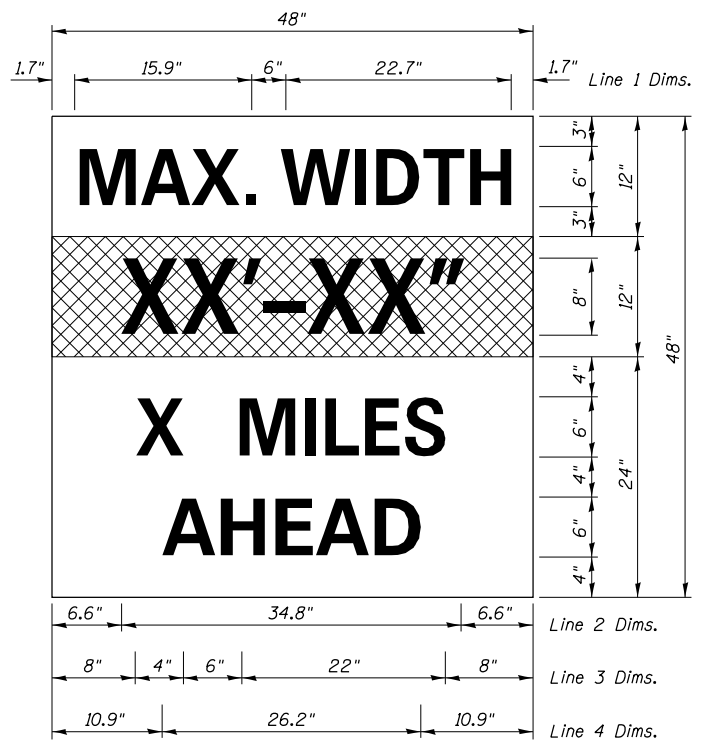
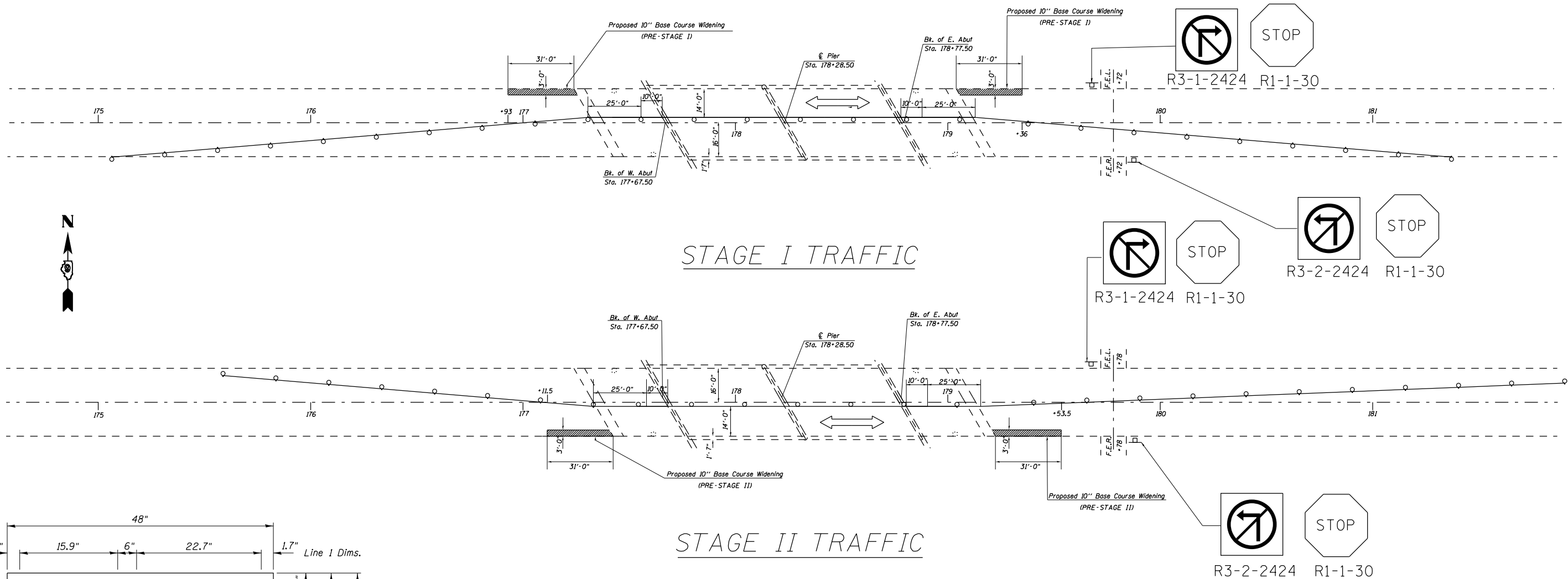

W12-I103
 W12-I103, No Border
 "MAX WIDTH" 6D, No Border, Black on White
 "XX'-XX'" 8D, No Border, Black on Orange
 "X MILES" 6D, No Border, Black on White
 "AHEAD" 6D, No Border, Black on White

- Notes for Max Width Sign:*
1. Install a Max Width Sign each direction on IL 141 to give traffic approaching work zone enough advance notice to change routes if needed. Exact locations as directed by engineer.
 2. The contractor shall furnish the posts and erect the signs at the locations directed by the engineer. All signs shall be post mounted.
 3. The noted work, including signs, posts, hardware and labor shall be included in the contract unit price, each, for Traffic Control and Protection, Std. 701316, no other compensation will be allowed.
 4. The width shown on the W12-I103 sign shall be 18" less than what is shown in the staged lane widths table or as directed by the Engineer.
 5. The "X" MILES AHEAD will be determined by the engineer.

MODEL: Default
 FILE: \\nas0101.pw.state.il.us\pub\baronm.dta\illroads\pww\DOT\Documents\IBDOT_Offices\Dist\ct_9\Projects\78724\CADD\Drawings\9_78724-Sheets.dgn

| | | |
|-----------------------------|-----------------|-----------|
| USER NAME = henkas | DESIGNED - ASH | REVISED - |
| DRAWN - ASH | REVISIONS - | |
| PLOT SCALE = 50.0000' / in. | CHECKED - MAS | REVISED - |
| PLOT DATE = 12/5/2019 | DATE - 11/12/19 | REVISED - |

**STATE OF ILLINOIS
 DEPARTMENT OF TRANSPORTATION**

PLAN STAGING

SCALE: SHEET OF SHEETS STA. TO STA.

| F.A.P. RTE. | SECTION | COUNTY | TOTAL SHEETS | SHEET NO. |
|---------------------------|------------------------------|--------|--------------|-----------|
| 877 | 09 BRIDGE DECK REPAIR 2020-1 | WHITE | 12 | 9 |
| CONTRACT NO. 78724 | | | | |
| ILLINOIS FED. AID PROJECT | | | | |

BUTT JOINT

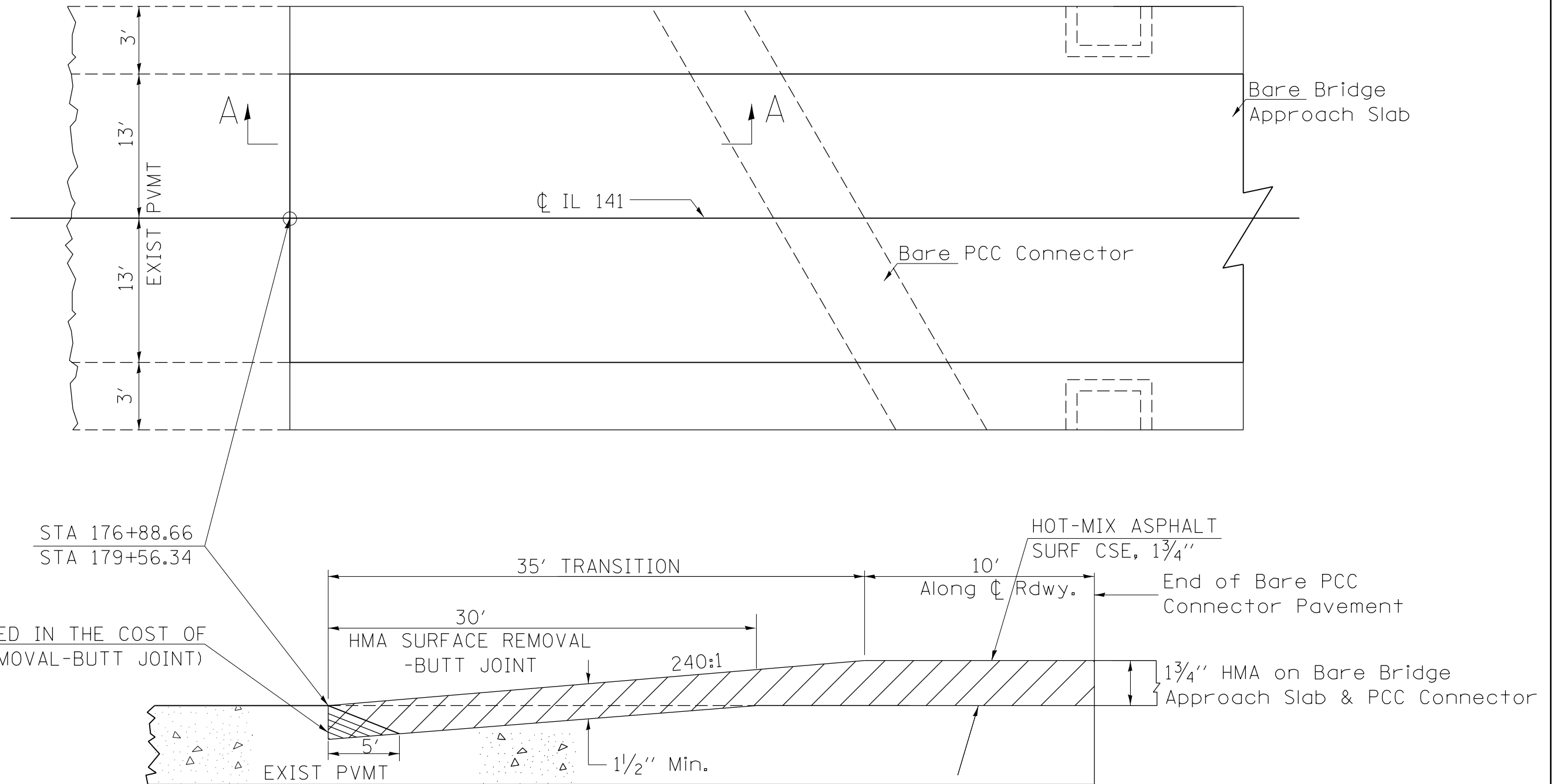

STA 176+88.66
STA 179+56.34

SAW CUT (INCLUDED IN THE COST OF
HMA SURFACE REMOVAL-BUTT JOINT)

SECTION A-A

TEMPORARY RAMP

| REVISIONS | |
|-----------|----------|
| DRAWN | 03-09-17 |
| REVISED | |
| REVISED | |
| REVISED | |

STD. 9-118

MODEL: Default
FILE: \\nas01c.pw.state.il.us\pub\baronm.d\illinois.gov\PI\DOT\Documents\DOT_Offices\District 9\Projects\78724\CADD\Drawings\9_78724-Sheets.dgn

| | | |
|-----------------------------|-----------------|-----------|
| USER NAME = henkas | DESIGNED - ASH | REVISED - |
| | DRAWN - ASH | REVISED - |
| PLOT SCALE = 50.0000' / in. | CHECKED - MAS | REVISED - |
| PLOT DATE = 12/5/2019 | DATE - 11/12/19 | REVISED - |

**STATE OF ILLINOIS
DEPARTMENT OF TRANSPORTATION**

BUTT JOINT DETAIL

SCALE: SHEET OF SHEETS STA. TO STA.

| F.A.P. RTE. | SECTION | COUNTY | TOTAL SHEETS | SHEET NO. |
|---------------------------|------------------------------|--------|--------------|-----------|
| 877 | D9 BRIDGE DECK REPAIR 2020-1 | WHITE | 12 | 10 |
| CONTRACT NO. 78724 | | | | |
| ILLINOIS FED. AID PROJECT | | | | |

