

BAR LIST - PER JOINT - STR #026-0066

BAR	NUMBER OF BARS		TOTAL	SIZE	LENGTH	SHAPE
	STAGE I	STAGE II				
α(E)	28		28	6	20'-9"	—
α1(E)		14	14	6	34'-6"	—
α2(E)	7	7	14	6	4'-0"	—
d(E)	4	4	8	5	3'-7"	—
d1(E)	4	4	8	4	4'-7"	—
d2(E)	4	4	8	4	2'-1"	□
CONCRETE REMOVAL				CU YD	12.3	
REINFORCEMENT BARS (EPOXY COATED)				POUND	1750	
CONCRETE SUPERSTRUCTURE				CU YD	12.3	

MINIMUM LAP #6 - 2' 7"

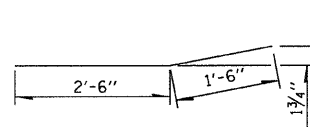

BAR α₂ (E)

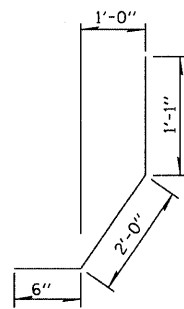

BAR d(E)

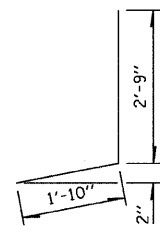

BAR d₁ (E)

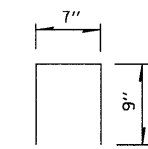

BAR d₂ (E)

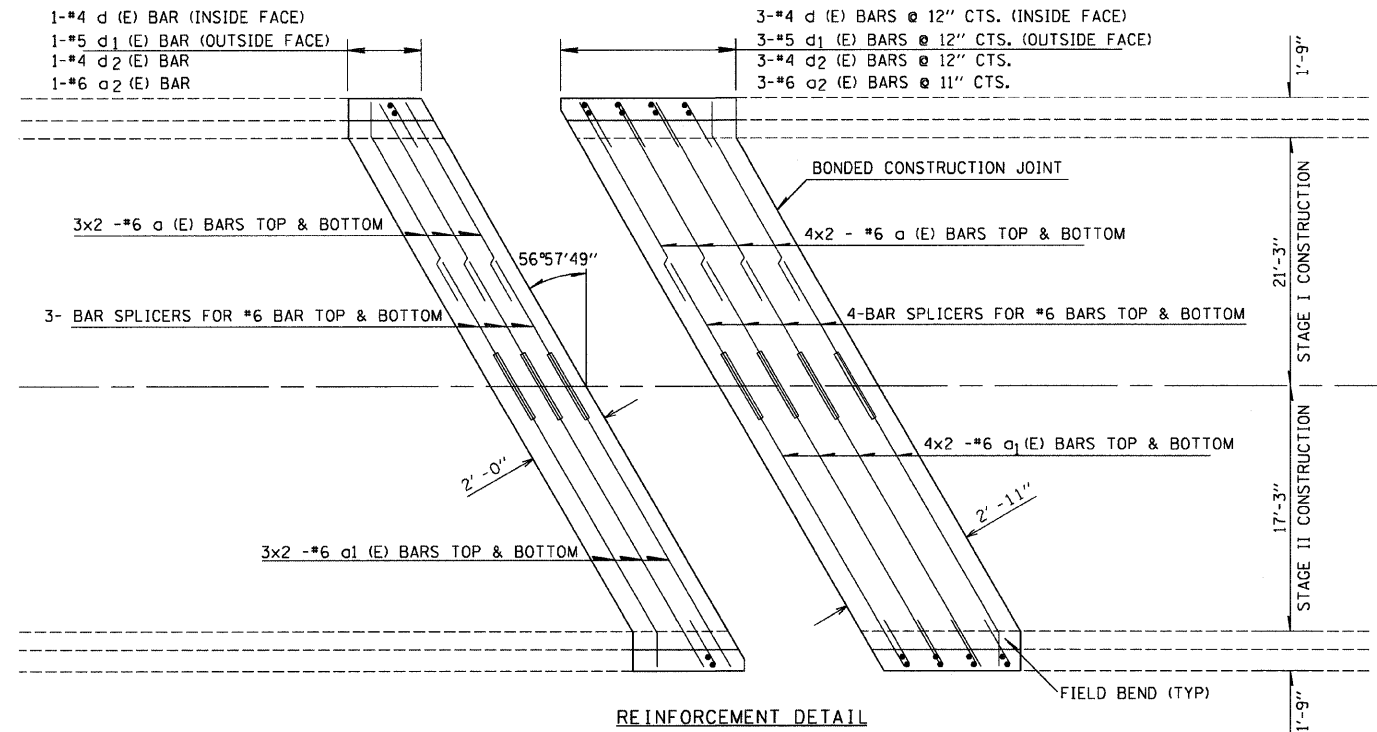

REINFORCEMENT DETAIL
 @ Hinges- Looking N @ Pier 2
 Pier 1 Similar by 180 degrees

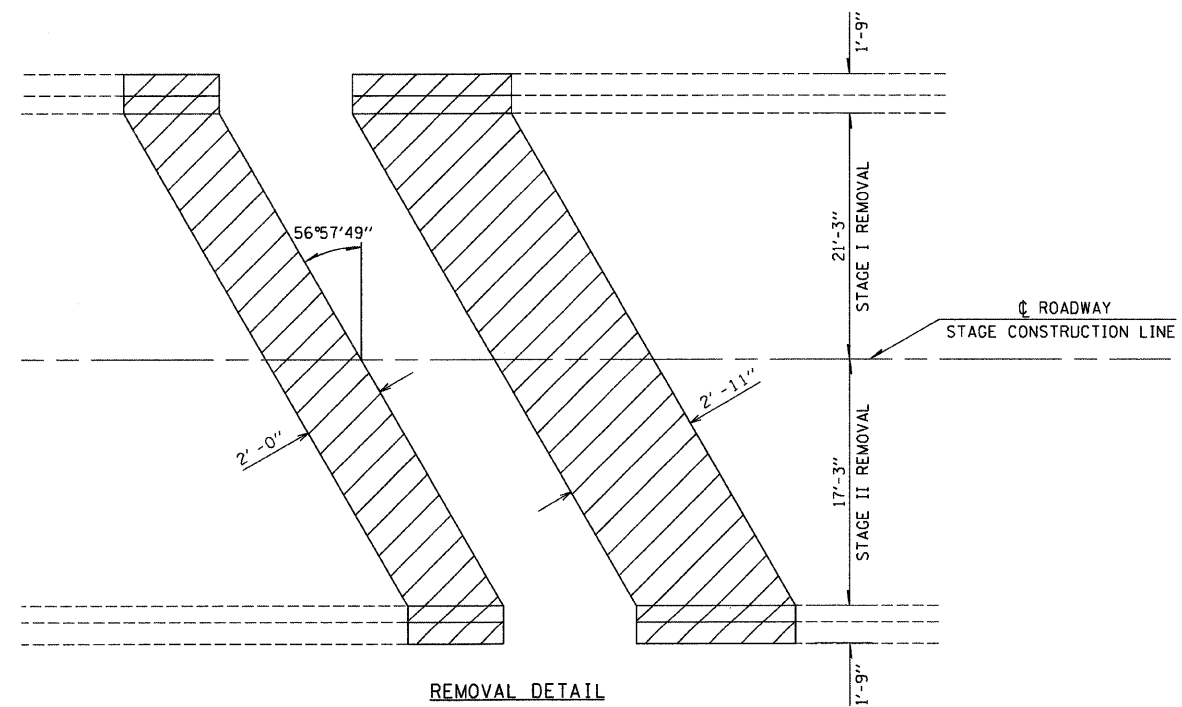

REMOVAL DETAIL

CONCRETE REMOVAL