

RAIL POST SHALL BE REMOVED AND THEN RE-ERECTED AFTER PLACEMENT OF CONCRETE SUPERSTRUCTURE. NEW RAIL POST ANCHORAGE DEVICES WILL BE REQUIRED AT EACH LOCATION WHERE POSTS ARE CONNECTED TO NEW CONSTRUCTION. COST SHALL BE INCLUDED WITH CONCRETE SUPERSTRUCTURE. SEE DETAIL ON SHEET 26 OF 31.

CONCRETE REMOVAL (LIMITS ARE FROM OUT TO OUT OF DECK)

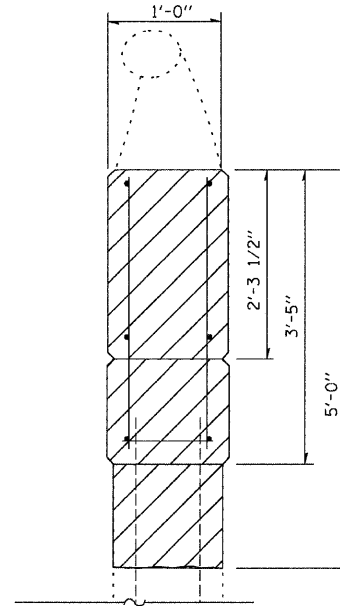

WINGWALL DETAIL

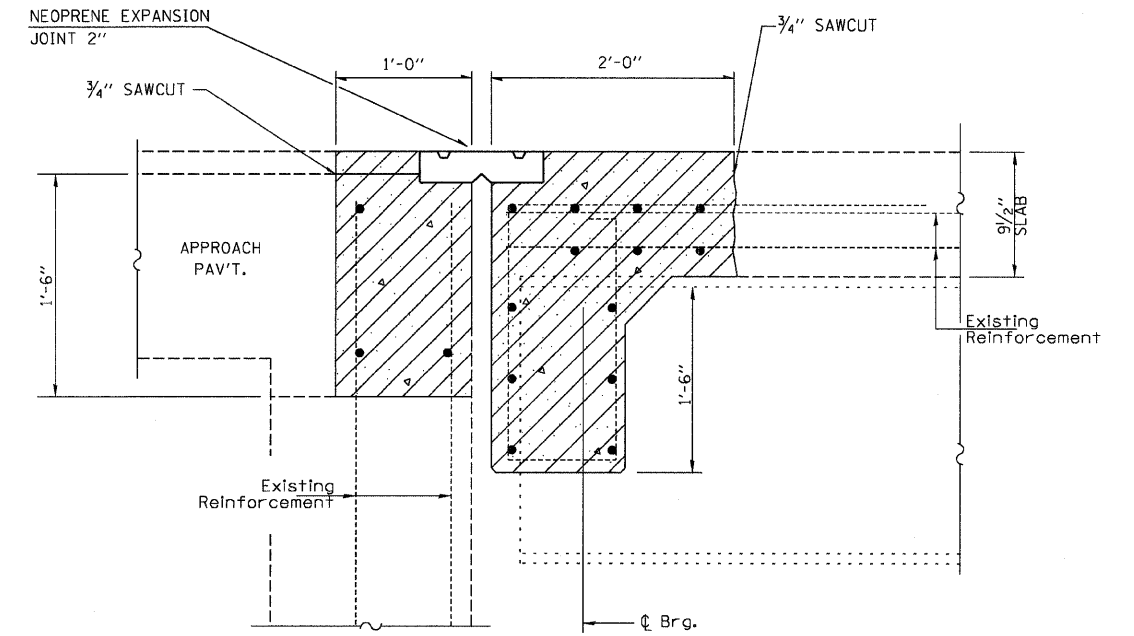

EXISTING EXPANSION JOINTS AT ABUTMENTS

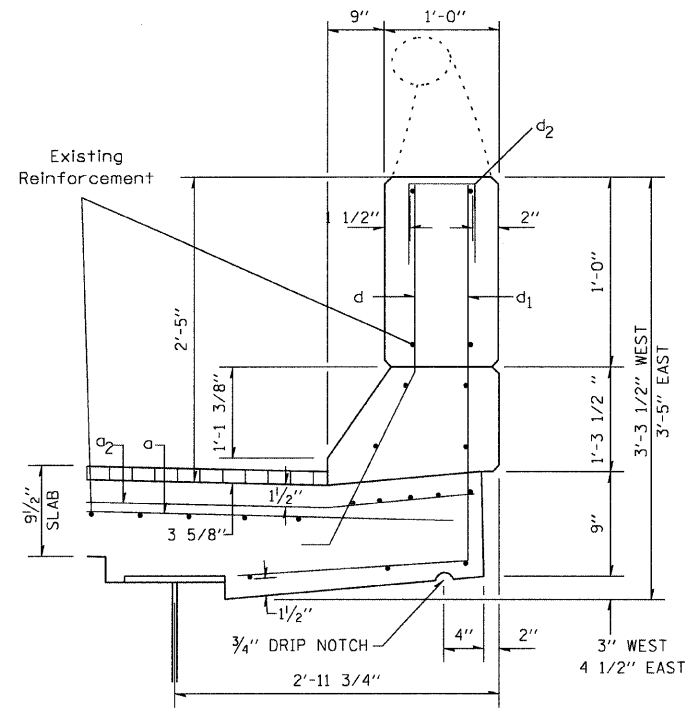

PARAPET DETAIL

PREFORMED JOINT STRIP SEAL FOR DETAIL OF EXPANSION JOINT SEE SHEET 24 OF 31.

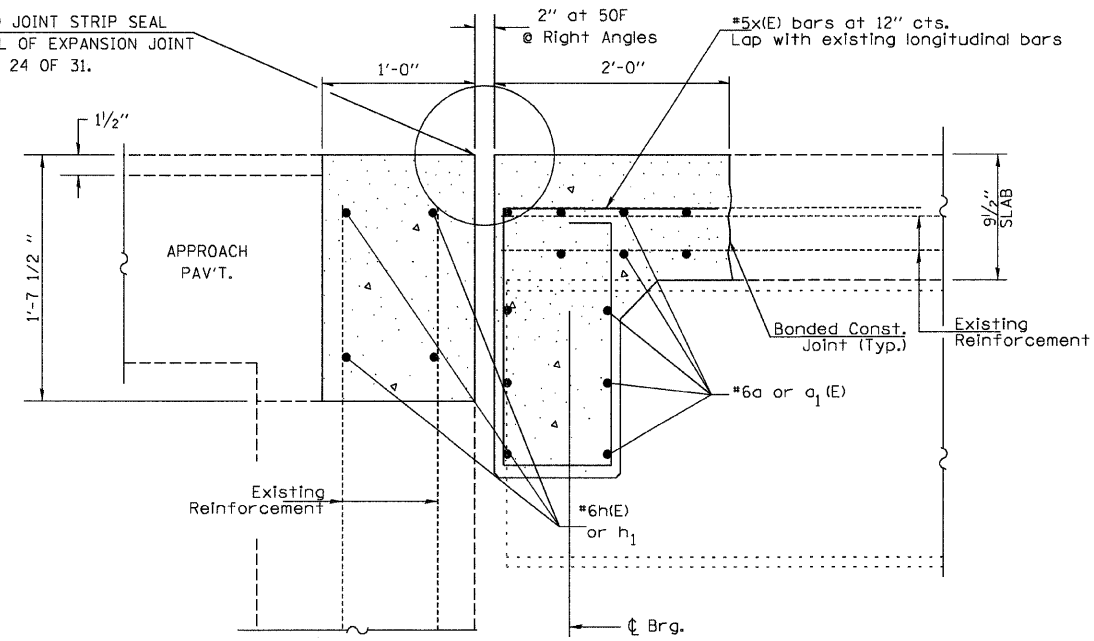

PROPOSED EXPANSION JOINTS AT ABUTMENTS

FILE NAME =	USER NAME = *USER*	DESIGNED - ---	REVISED - ---	<b>STATE OF ILLINOIS DEPARTMENT OF TRANSPORTATION</b>	<b>EXPANSION JOINT &amp; REBAR DETAILS 058-0067</b>	F.A.J. RTE.	SECTION	COUNTY	TOTAL SHEETS	SHEET NO.	
*FILEL*		DRAWN - ---	REVISED - ---			72	D7 BRIDGE REPAIRS 2008-2	MACON	31	20	
PLOT SCALE = *SCALE*		CHECKED - ---	REVISED - ---			CONTRACT NO. 74270					
PLOT DATE = *DATE*		DATE - ---	REVISED - ---			FED. ROAD DIST. NO. ILLINOIS FED. AID PROJECT					
SCALE: 20						SHEET NO. OF SHEETS		STA. TO STA.			