

87351

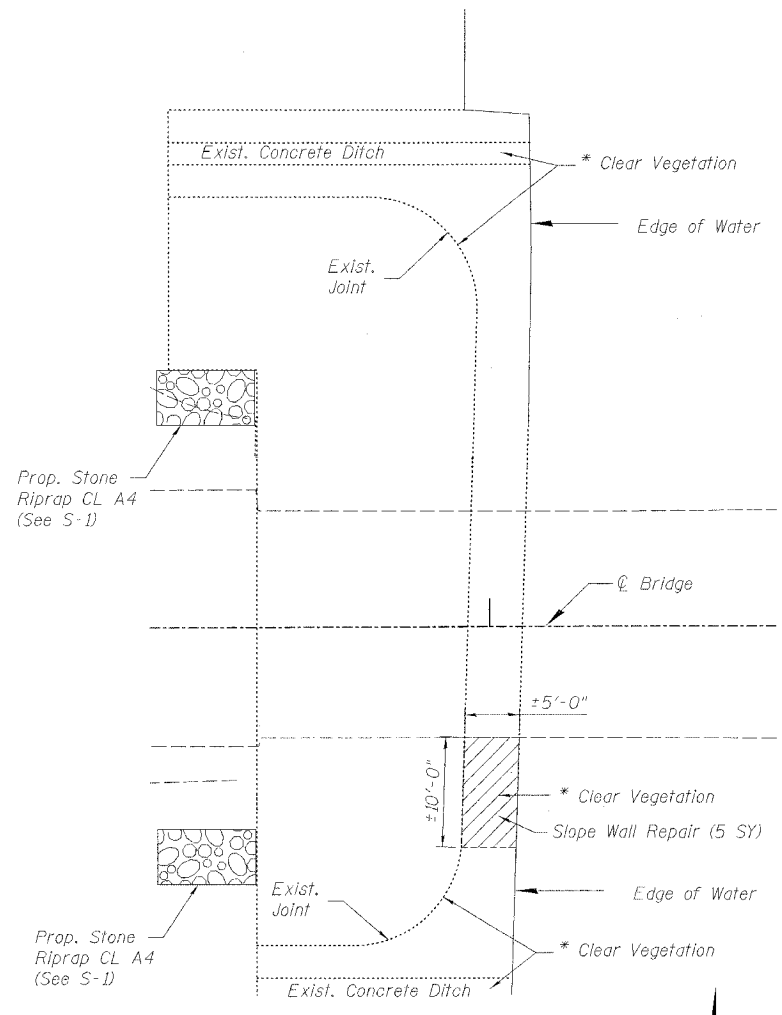

WEST SLOPEWALL REPAIR PLAN

* Clearing vegetation shall not be paid for separately, but shall be included in the cost of Slopewall Repair. Clearing vegetation shall be done in accordance with the applicable portions of Section 201 of the Standard Specifications.

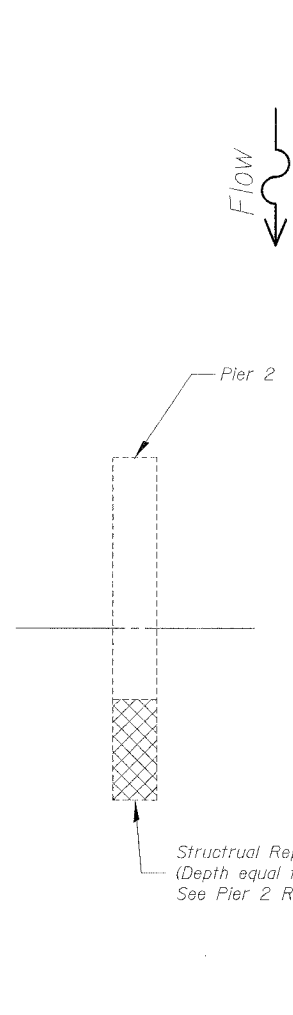

PIER 2 REPAIR PLAN

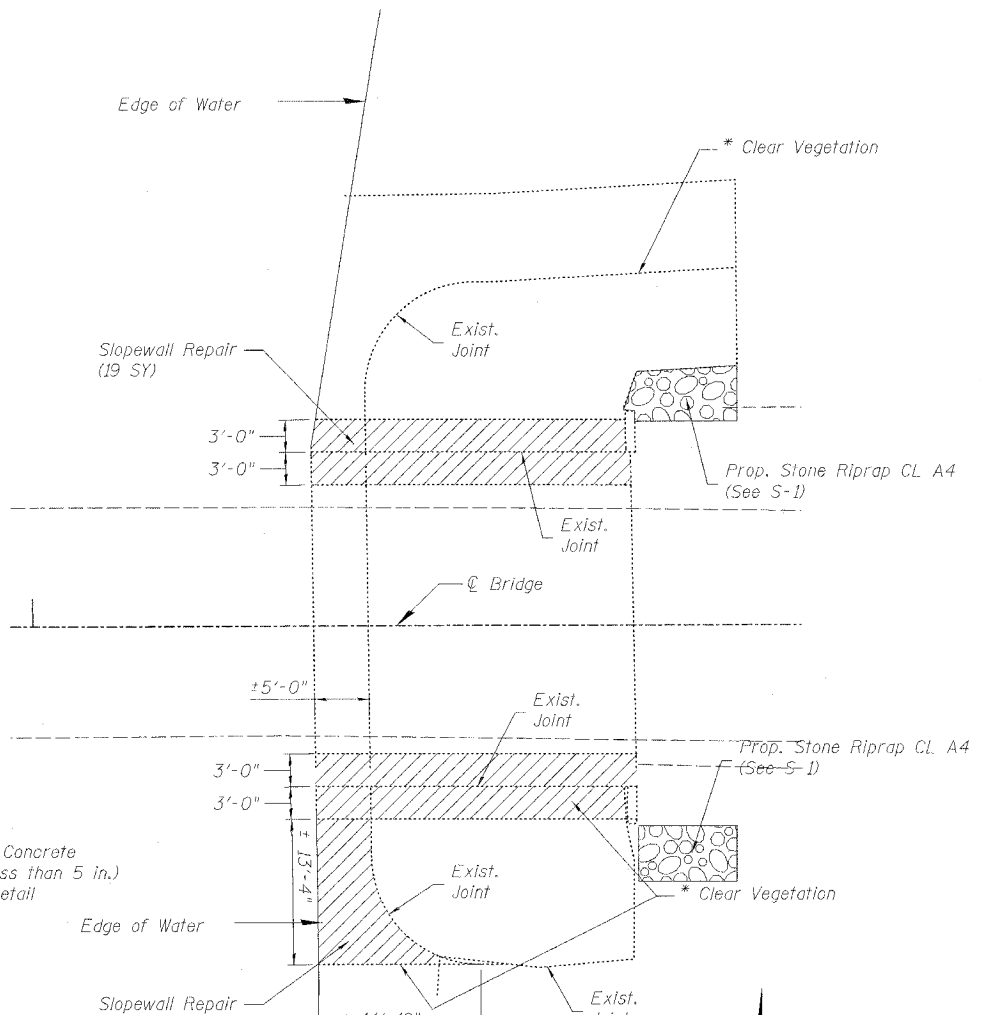

EAST SLOPEWALL REPAIR PLAN

* Clearing vegetation shall not be paid for separately, but shall be included in the cost of Slopewall Repair. Clearing vegetation shall be done in accordance with the applicable portions of Section 201 of the Standard Specifications.

LEGEND

- Indicates Area of Slopewall Repair
- Indicates Area of Structural Repair of Concrete (Depth Equal to or Less than 5 inches)

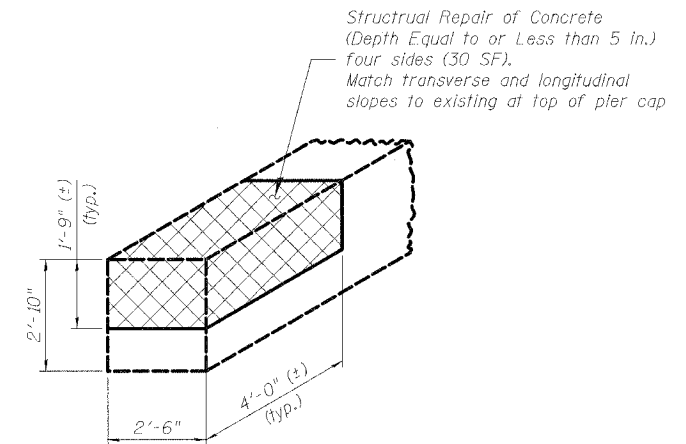

PIER 2 REPAIR DETAIL

Looking at South End

BILL OF MATERIAL

Item	Unit	Total
Structural Repair of Concrete (Depth Less Than or Equal to 5")	Sq. Ft.	30
Slopewall Repair	Sq. Yd.	53

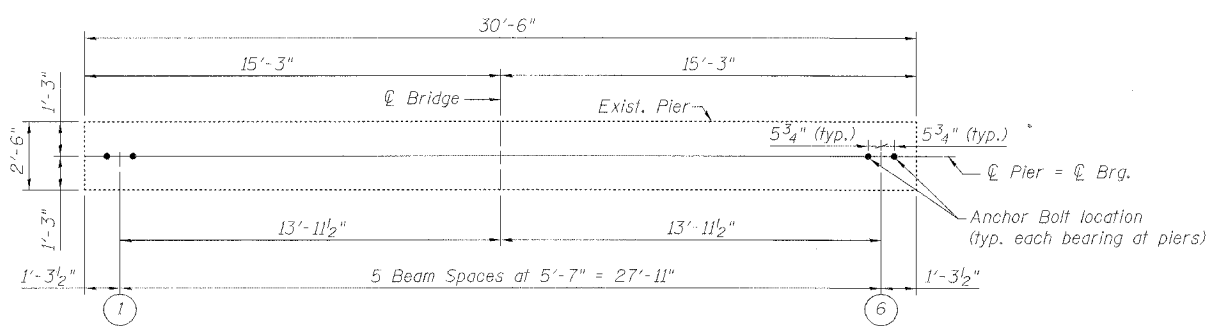

PIER ANCHOR BOLT LOCATION PLAN

(Typ. Each Pier)

APPROXIMATE EXISTING BEARING SEAT ELEVATION AT PIERS

	± Brg. Pier 1	± Brg. Pier 2	± Brg. Pier 3
± Beam 1	644.94	645.66	646.43
± Beam 2	645.03	645.75	646.52
± Beam 3	645.12	645.84	646.61
± Beam 4	645.12	645.84	646.61
± Beam 5	645.03	645.75	646.52
± Beam 6	644.94	645.66	646.43

Included for bidders information only. Existing Bearing Seat elevations are based on information from the existing design plans and should be field verified.

DESIGNED	KMA
CHECKED	AEU
DRAWN	WJH
CHECKED	RGD

SEC GROUP, INC.
Illinois Professional Design Firm # 184-000108
Smith Engineering Consultants • SEC Automation • SEC Planning
4500 Prime Parkway, McHenry, IL 60050
T. 815.385.1778 F. 815.385.1781
www.secgroupinc.com engineering@secgroupinc.com

LASALLE COUNTY HIGHWAY DEPARTMENT
SUBSTRUCTURE & SLOPEWALL REPAIR DETAILS
LASALLE STREET
OVER SOMONAUK CREEK
VILLAGE OF SOMONAUK
SECTION NO. 05-00627-00-BR
STRUCTURE NO. 050-3057
DATE 11-16-2007

COMPANY NAME: Smith Engineering Consultants
 COUNTY: LASALLE
 PROJECT: 05-00627-00-BR
 SHEET: S-16
 DATE: 11-16-2007