

STATE OF ILLINOIS  
DEPARTMENT OF TRANSPORTATION  
DIVISION OF HIGHWAYS

**PROPOSED  
HIGHWAY PLANS**

FAP ROUTE 502 (IL 57)  
SECTION 42BR  
PROJECT NHPP-ZWF1(416)  
BRIDGE REPLACEMENT WITH BOX CULVERT  
ADAMS COUNTY

C-96-033-22

F.A.P. RTE.	SECTION	COUNTY	TOTAL SHEETS	SHEET NO.
502	42BR	ADAMS	38	1
		ILLINOIS	CONTRACT NO. 72G18	

D-96-029-22

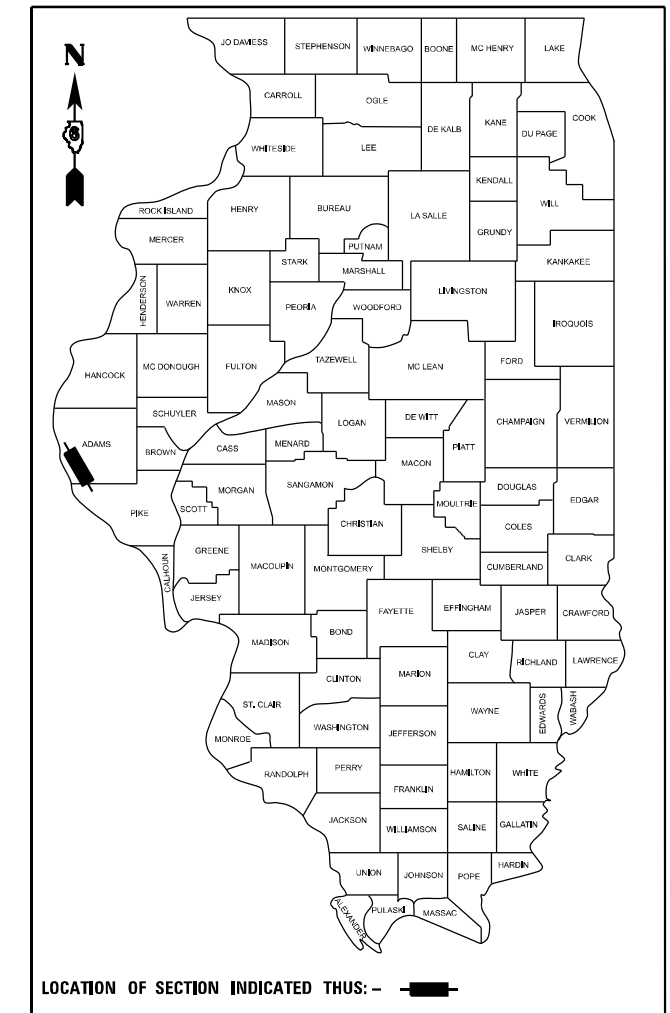

**E** LIN ENGINEERING, LTD.  
Consulting Engineers  
Westmont, Illinois

FOR INDEX OF SHEETS, SEE SHEET NO. 2

FAP 520 (IL 57)  
ADT-4,150 (2023)  
CLASSIFICATION - OTHER PRINCIPAL ARTERIAL  
PV = 83.49%  
SV = 3.86%  
MU = 12.65%

EXISTING SN 001-0016  
HARKNESS CREEK SE OF MARBLEHEAD  
STA 108 + 57.25 TO 109 + 42.75  
REMOVE EXISTING STRUCTURE  
REPLACE WITH 10'W X 10'H TRIPLE BOX CULVERT  
PROPOSED SN 001-2503

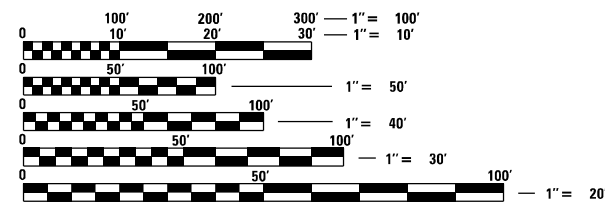

FULL SIZE PLANS HAVE BEEN PREPARED USING STANDARD ENGINEERING SCALES, REDUCED SIZED PLANS WILL NOT CONFORM TO STANDARD SCALES. IN MAKING MEASUREMENTS ON REDUCED PLANS, THE ABOVE SCALES MAY BE USED.

J.U.L.I.E.  
JOINT UTILITY LOCATION INFORMATION FOR EXCAVATION  
1-800-892-0123  
OR 811

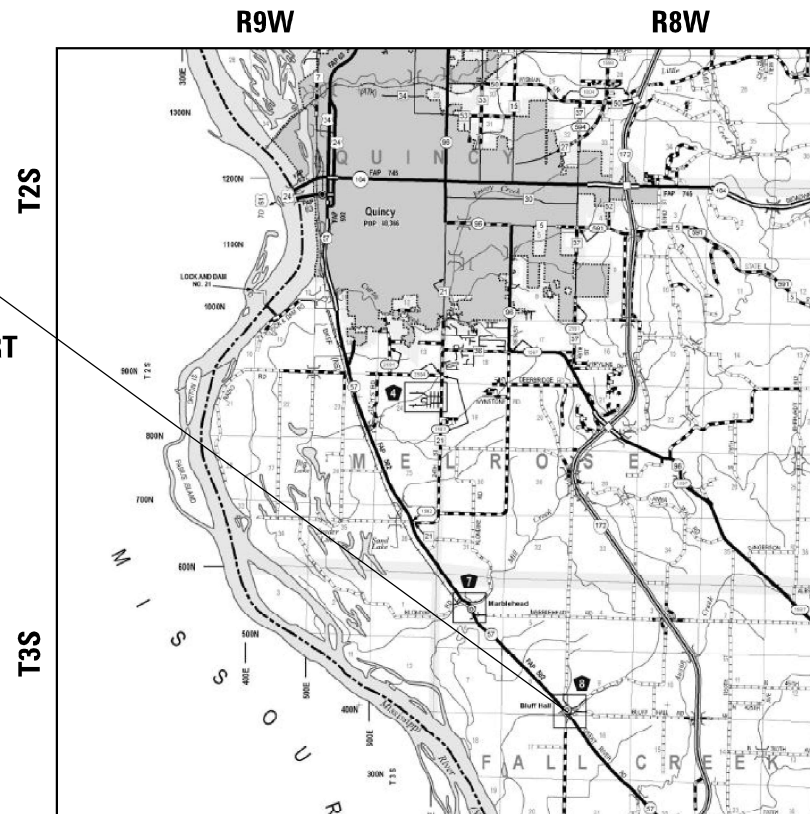

PROJECT ENGINEER: JON KELLEY 217-785-2739  
PROJECT MANAGER: BRIAN MINDER 217-557-7897

GROSS LENGTH = 504 FT. = 0.095 MILE  
NET LENGTH = 356 FT. = 0.067 MILE

Shiraz Tarique  
Illinois Registered Engineer No. 062-064219  
Registration Expires Nov. 30, 2025

12-27-24

CONTRACT NO. 72G18

STATE OF ILLINOIS  
DEPARTMENT OF TRANSPORTATION  
DIVISION OF HIGHWAYS

SUBMITTED December 26 2024

*Debra P. Meyer*  
DEPUTY DIRECTOR OF HIGHWAYS, REGION ENGINEER

January 31 2025  
*Shiraz Tarique*  
ENGINEER OF DESIGN AND ENVIRONMENT

January 31 2025  
*Shiraz Tarique*  
DIRECTOR OF HIGHWAYS PROJECT IMPLEMENTATION

**PRINTED BY THE AUTHORITY  
OF THE STATE OF ILLINOIS**

**INDEX OF SHEETS**

- 1 COVER SHEET
- 2 INDEX, HIGHWAY STANDARDS & GENERAL NOTES
- 3 - 6 SUMMARY OF QUANTITIES
- 7 - 8 SCHEDULES OF QUANTITIES
- 9 - 10 ALIGNMENT, TIES, AND BENCHMARKS
- 11 TYPICAL SECTIONS
- 12 - 15 STAGING PLAN
- 16 WIDTH RESTRICTION SIGNING DETAIL
- 17 REMOVAL PLAN
- 18 ROADWAY PLAN & PROFILE
- 19 EROSION CONTROL PLAN
- 20 - 26 STRUCTURAL PLANS - S.N. 001-2503
- 27 - 36 CROSS SECTIONS
- 37 - 38 GRANULAR BACKFILL DETAILS

**HIGHWAY STANDARDS**

- 000001-08 STANDARD SYMBOLS, ABBREVIATIONS AND PATTERNS
- 001001-02 AREAS OF REINFORCEMENT BARS
- 001006 DECIMAL OF AN INCH AND OF A FOOT
- 280001-07 TEMPORARY EROSION CONTROL SYSTEMS
- 515001-04 NAME PLATE FOR BRIDGES
- 630001-13 STEEL PLATE BEAM GUARDRAIL
- 630301-09 SHOULDER WIDENING FOR TYPE 1 (SPECIAL) GUARDRAIL TERMINALS
- 701001-02 OFF-ROAD OPERATIONS, 2L, 2W, MORE THAN 15' (4.5 M) AWAY
- 701006-05 OFF-ROAD OPERATIONS, 2L, 2W, 15' (4.5 M) TO 24" (600 MM) FROM PAVEMENT EDGE
- 701201-05 LANE CLOSURE, 2L, 2W, DAY ONLY, FOR SPEEDS ≥ 45 MPH
- 701311-03 LANE CLOSURE, 2L, 2W MOVING OPERATIONS - DAY ONLY
- 701321-19 LANE CLOSURE, 2L, 2W, BRIDGE REPAIR WITH BARRIER
- 701326-04 LANE CLOSURE, 2L, 2W, PAVEMENT WIDENING FOR SPEEDS ≥ 45 MPH
- 701901-10 TRAFFIC CONTROL DEVICES
- 704001-08 TEMPORARY CONCRETE BARRIER
- 725001-01 OBJECT AND TERMINAL MARKERS
- 780001-05 TYPICAL PAVEMENT MARKINGS
- 782006-01 GUARDRAIL AND BARRIER WALL REFLECTOR MOUNTING DETAILS
- BLR 21-9 TYPICAL APPLICATION OF TRAFFIC CONTROL DEVICES FOR CONSTRUCTION ON RURAL LOCAL HIGHWAYS
- 420001-10 PAVEMENT JOINTS

**GENERAL NOTES**

1. IT SHALL BE THE CONTRACTORS RESPONSIBILITY TO VERIFY ALL DIMENSIONS AND CONDITIONS EXISTING IN THE FIELD PRIOR TO CONSTRUCTION AND ORDERING MATERIALS.
2. THE CONTRACTOR SHALL NOTIFY THE IDOT DISTRICT 6 BUREAU OF OPERATIONS AT (217) 785-5306 THREE WEEKS PRIOR TO IMPLEMENTING TRAFFIC CONTROL.
3. THE DISTRICT 6 BUREAU OF OPERATIONS SHALL BE NOTIFIED AT LEAST 14 DAYS PRIOR TO PLACEMENT OF FINAL PAVEMENT MARKINGS AT (217) 785-5306. THE RESIDENT ENGINEER SHALL VERIFY AND DOCUMENT ALL NO PASSING ZONES AND CONTACT THE TRAFFIC OPERATIONS ENGINEER WITH ANY CONCERNS WITHIN THE 14 DAY NOTIFICATION PERIOD SO THEY CAN BE EVALUATED PRIOR TO THE PLACEMENT OF FINAL PAVEMENT MARKING.
4. ALL ELEVATIONS SHOWN ON THE PLANS ARE ESTABLISHED FROM NAVD-88.
5. THE CONTRACTOR SHALL CONTAIN AMEREN ILLINOIS AT (217) 221-0809 TO DETERMINE IF DE-ENERGIZATION OF THE POWER LINES RUNNING ALONG WITH SOUTH SIDE OF IL 57 IS REQUIRED. 10 FT OF SEPARATION IS NEEDED BETWEEN THE POWER LINE AND THE CONTRACTOR'S EQUIPMENT.

**COMMITMENTS**

NONE.

THE FOLLOWING RATES OF APPLICATION HAVE BEEN USED TO CALCULATE PLAN QUANTITIES:

AGGREGATE SHOULDERS	1.60 TONS/CU YD
NITROGEN FERTILIZER NUTRIENT	90 LB/ACRE
PHOSPHORUS FERTILIZER NUTRIENT	90 LB/ACRE
POTASSIUM FERTILIZER NUTRIENT	90 LB/ACRE
GRANULAR MATERIAL	1.80 TONS/CU YD
MULCH	2 TON/ACRE
BITUMINOUS MATERIALS (TACK COAT)	0.025 LBS/SQ FT (HMA LIFTS)
BITUMINOUS MATERIALS (TACK COAT)	0.05 LBS/SQ FT (MILLED SURFACE)

THE FOLLOWING MIXTURE REQUIREMENTS ARE APPLICABLE

LOCATIONS:	IL 57	IL 57
MIXTURE USE(S):	HMA BASE COURSE WIDENING, 2"	HMA BASE COURSE WIDENING, 7"
AC/PG:	PG 64-22	PG 64-22
DESIGN AIR VOIDS:	4.0% @ N DESIGN = 70	4.0% @ N DESIGN = 70
MIXTURE COMPOSITION (GRADATION MIXTURE)	IL-9.5	IL-19.0
FRICTION AGGREGATE:	MIX "D"	N/A
QUALITY MANAGEMENT	QC/QA	QC/QA
SUBLOT SIZE:	N/A	N/A
MTD:	NO	NO

**MIXTURE TABLE NOTES**

1. THE UNIT WEIGHT USED TO CALCULATE ALL HOT-MIX ASPHALT SURFACE MIXTURE QUANTITIES IS 112 LBS/SQYD/IN.

**STATE OF ILLINOIS  
DEPARTMENT OF TRANSPORTATION  
DIVISION OF HIGHWAYS  
DISTRICT 6**

EXAMINED November 22, 20 24

*[Signature]*  
ENGINEER OF OPERATIONS

EXAMINED December 9, 20 24

*[Signature]*  
ENGINEER OF PROJECT IMPLEMENTATION

EXAMINED December 12, 20 24

*[Signature]*  
ENGINEER OF PROGRAM DEVELOPMENT

MODEL: Typical01.dwg  
FILE NAME: E:\2024\4\CD\DD\_Sheets\0672618.mxd.dgn



USER NAME = rober	DESIGNED - JK	REVISED -
	DRAWN - JK	REVISED -
PLOT SCALE = 0.16666667 / in.	CHECKED - RC	REVISED -
PLOT DATE = \$DATE\$	DATE - 11/2024	REVISED -

**STATE OF ILLINOIS  
DEPARTMENT OF TRANSPORTATION**

**IL RTE 57 OVER HARKNESS CREEK  
INDEX, HIGHWAY STANDARDS & GENERAL NOTES**

SCALE: N.T.S. SHEET 1 OF 1 SHEETS STA. TO STA.

F.A.P. RTE.	SECTION	COUNTY	TOTAL SHEETS	SHEET NO.
502	42BR	ADAMS	38	2
CONTRACT NO. 72G18				
ILLINOIS FED. AID PROJECT				

REV - MS

CONSTRUCTION CODE
6-00193-0000
80% FED 20% STATE
SN 001-2503
0010
BRIDGE

CODE NO.	ITEM	UNIT	TOTAL QUANTITY	
20200100	EARTH EXCAVATION	CU YD	35	35
25000210	SEEDING, CLASS 2A	ACRE	0.25	0.25
25000400	NITROGEN FERTILIZER NUTRIENT	POUND	30	30
25000500	PHOSPHORUS FERTILIZER NUTRIENT	POUND	30	30
25000600	POTASSIUM FERTILIZER NUTRIENT	POUND	30	30
25100115	MULCH, METHOD 2	ACRE	0.25	0.25
25100635	HEAVY DUTY EROSION CONTROL BLANKET	SQ YD	171	171
28000400	PERIMETER EROSION BARRIER	FOOT	679	679
28100107	STONE RIPRAP, CLASS A4	SQ YD	130	130
28200200	FILTER FABRIC	SQ YD	135	135
31101400	SUBBASE GRANULAR MATERIAL, TYPE B 6"	SQ YD	247	247
35300700	PORTLAND CEMENT CONCRETE BASE COURSE 12"	SQ YD	162	162
35650400	BASE COURSE WIDENING 9"	SQ YD	503	503
44000100	PAVEMENT REMOVAL	SQ YD	285	285

\* SPECIALTY ITEM

REV - MS

MODEL: 500 SHEET 1  
FILE NAME: E:\2021-4\CADD-Sheets\057218-500.dgn



USER NAME = rober	DESIGNED - JK	REVISED -
	DRAWN - JK	REVISED -
PLOT SCALE = 0.16666667 ' / in.	CHECKED - RC	REVISED -
PLOT DATE = \$DATE\$	DATE - 11/2024	REVISED -

**STATE OF ILLINOIS  
DEPARTMENT OF TRANSPORTATION**

<b>IL RTE 57 OVER HARKNESS CREEK SUMMARY OF QUANTITIES</b>		
SCALE: N.T.S.	SHEET 1 OF 4 SHEETS	STA. TO STA.

F.A.P. RTE.	SECTION	COUNTY	TOTAL SHEETS	SHEET NO.
502	42BR	ADAMS	38	3
CONTRACT NO. 72G18				
ILLINOIS FED. AID PROJECT				

CONSTRUCTION CODE
6-00193-0000
80% FED 20% STATE
SN 001-2503
0010
BRIDGE

CODE NO.	ITEM	UNIT	TOTAL QUANTITY	
44004250	PAVED SHOULDER REMOVAL	SQ YD	104	104
48101600	AGGREGATE SHOULDERS, TYPE B, 8"	SQ YD	57	57
48102100	AGGREGATE WEDGE SHOULDERS, TYPE B	TON	12	12
50100100	REMOVAL OF EXISTING STRUCTURES	EACH	1	1
51500100	NAME PLATES	EACH	1	1
54001001	BOX CULVERT END SECTIONS, CULVERT NO. 1	EACH	2	2
54011010	PRECAST CONCRETE BOX CULVERTS 10'X10'	FOOT	207	207
50200450	REMOVAL AND DISPOSAL OF UNSUITABLE MATERIAL FOR STRUCTURES	CU YD	145	145
52200010	TEMPORARY SHEET PILING	SQ FT	725	725
52200600	GEOTEXTILE RETAINING WALL	SQ FT	138	138
* 63000001	STEEL PLATE BEAM GUARDRAIL, TYPE A, 6 FOOT POSTS	FOOT	137.5	137.5
* 63100167	TRAFFIC BARRIER TERMINAL, TYPE 1 (SPECIAL) TANGENT	EACH	2	2
63200310	GUARDRAIL REMOVAL	FOOT	366	366
67000400	ENGINEER'S FIELD OFFICE, TYPE A	CAL MO	12	12

\* SPECIALTY ITEM

MODEL: SDO SHEET 2  
FILE NAME: E:\2021-4\CADD\_Sheets\067218-SDO.dgn



USER NAME = r0ber	DESIGNED - JK	REVISED -
	DRAWN - JK	REVISED -
PLOT SCALE = 0.16666667 ' / in.	CHECKED - RC	REVISED -
PLOT DATE = \$DATES	DATE - 11/2024	REVISED -

STATE OF ILLINOIS  
DEPARTMENT OF TRANSPORTATION

IL RTE 57 OVER HARKNESS CREEK  
SUMMARY OF QUANTITIES

SCALE: N.T.S. SHEET 2 OF 4 SHEETS STA. TO STA.

F.A.P. RTE.	SECTION	COUNTY	TOTAL SHEETS	SHEET NO.
502	42BR	ADAMS	38	4
CONTRACT NO. 72G18				
ILLINOIS FED. AID PROJECT				

CONSTRUCTION CODE
6-00193-0000
80% FED 20% STATE
SN 001-2503
0010
BRIDGE

CODE NO.	ITEM	UNIT	TOTAL QUANTITY	
67100100	MOBILIZATION	L SUM	1	1
70100405	TRAFFIC CONTROL AND PROTECTION, STANDARD 701321	EACH	1	1
70100450	TRAFFIC CONTROL AND PROTECTION, STANDARD 701201	L SUM	1	1
70100500	TRAFFIC CONTROL AND PROTECTION, STANDARD 701326	L SUM	1	1
70106500	TEMPORARY BRIDGE TRAFFIC SIGNALS	EACH	1	1
70106700	TEMPORARY RUMBLE STRIPS	EACH	6	6
70107025	CHANGEABLE MESSAGE SIGN	CAL DA	250	250
70300100	SHORT TERM PAVEMENT MARKING	FOOT	206	206
70300150	SHORT TERM PAVEMENT MARKING REMOVAL	SQ FT	69	69
70400100	TEMPORARY CONCRETE BARRIER	FOOT	287.5	287.5
70400200	RELOCATE TEMPORARY CONCRETE BARRIER	FOOT	225.0	225.0
70600260	IMPACT ATTENUATORS, TEMPORARY (FULLY REDIRECTIVE, NARROW), TEST LEVEL 3	EACH	2	2
70600332	IMPACT ATTENUATORS, RELOCATE (FULLY REDIRECTIVE, NARROW), TEST LEVEL 3	EACH	2	2
* 72501000	TERMINAL MARKER - DIRECT APPLIED	EACH	2	2

\* SPECIALTY ITEM

MODEL: SDO\_SHEET3  
FILE NAME: E:\2024\CADD\_Sheets\072G18-SDO.dgn



USER NAME = r0ber	DESIGNED - JK	REVISED -
	DRAWN - JK	REVISED -
PLOT SCALE = 0.16666667 ' / in.	CHECKED - RC	REVISED -
PLOT DATE = \$DATES	DATE - 11/2024	REVISED -

STATE OF ILLINOIS  
DEPARTMENT OF TRANSPORTATION

IL RTE 57 OVER HARKNESS CREEK  
SUMMARY OF QUANTITIES

SCALE: N.T.S. SHEET 3 OF 4 SHEETS STA. TO STA.

F.A.P. RTE.	SECTION	COUNTY	TOTAL SHEETS	SHEET NO.
502	42BR	ADAMS	38	5
CONTRACT NO. 72G18				
ILLINOIS FED. AID PROJECT				

CONSTRUCTION CODE
6-00193-0000
80% FED 20% STATE
SN 001-2503
0010
BRIDGE

CODE NO.	ITEM	UNIT	TOTAL QUANTITY	
* 78009005	MODIFIED URETHANE PAVEMENT MARKING - LINE 5"	FOOT	1,171	1,171
* 78200005	GUARDRAIL REFLECTORS, TYPE A	EACH	4	4
78300200	RAISED REFLECTIVE PAVEMENT MARKER REMOVAL	EACH	3	3
78300201	PAVEMENT MARKING REMOVAL - GRINDING	SQ FT	488	488
X5020108	GRANULAR CULVERT BACKFILL	CU YD	326	326
X7011800	TRAFFIC CONTROL AND PROTECTION, STANDARD BLR 21	L SUM	1	1
X7200201	WIDTH RESTRICTION SIGNING	L SUM	1	1
Z0013798	CONSTRUCTION LAYOUT	L SUM	1	1
* Z0054517	ROCK FILL - FOUNDATION	TON	132	132
∅ Z0076600	TRAINEES	HOUR	1500	1500
∅ Z0076604	TRAINEES TRAINING PROGRAM GRADUATE	HOUR	1500	1500

\* SPECIALTY ITEM  
∅ 0042

REV - MS

MODEL: 500 SHEET 4  
FILE NAME: E:\021-4\CADD-Sheets\021G18-500.dgn



USER NAME = rober	DESIGNED - JK	REVISED -
	DRAWN - JK	REVISED -
PLOT SCALE = 0.16666667 / in.	CHECKED - RC	REVISED -
PLOT DATE = \$DATE\$	DATE - 11/2024	REVISED -

**STATE OF ILLINOIS  
DEPARTMENT OF TRANSPORTATION**

**IL RTE 57 OVER HARKNESS CREEK  
SUMMARY OF QUANTITIES**

F.A.P. RTE.	SECTION	COUNTY	TOTAL SHEETS	SHEET NO.
502	42BR	ADAMS	38	6
CONTRACT NO. 72G18				
ILLINOIS FED. AID PROJECT				

SCALE: N.T.S. SHEET 4 OF 4 SHEETS STA. TO STA.

**LANDSCAPING TABLE**

ALIGNMENT	FROM STATION	TO STATION	LT/RT	NITROGEN FERTILIZER NUTRIENT	PHOSPHORUS FERTILIZER NUTRIENT	POTASSIUM FERTILIZER NUTRIENT	SEEDING, CLASS 2A	MULCH METHOD 2	HEAVY DUTY EROSION CONTROL BLANKET	PERIMETER EROSION BARRIER
				POUND	POUND	POUND	ACRE	ACRE	SQ YD	FOOT
IL 57	106+90.52	107+15.87	LT	1.00	1.00	1.00	0.00	0.00		35.45
IL 57	106+90.52	108+89.10	RT	10.00	10.00	10.00	0.09	0.09		256.05
IL 57	107+63.69	108+00.00	RT	2.00	2.00	2.00	0.01		44.69	
IL 57	107+79.98	108+50.00	LT	2.00	2.00	2.00	0.01	0.01		102.83
IL 57	108+50.00	109+50.00	LT	4.00	4.00	4.00	0.03	0.01		
IL 57	108+71.42	108+98.36	LT	2.00	2.00	2.00	0.01		125.69	36.65
IL 57	109+03.12	109+94.37	RT	6.00	6.00	6.00	0.05	0.05		108.83
IL 57	109+10.35	109+28.58	LT	1.00	1.00	1.00	0.00	0.00		28.03
IL 57	109+50.00	110+29.79	LT	2.00	2.00	2.00	0.01	0.01		110.76
ROUNDED TOTAL				30	30	30	0.25	0.25	171	679

**AGGREGATE WEDGE SHOULDERS, TYPE B**

ALIGNMENT	FROM STATION	TO STATION	LT/RT	TON
IL 57	106+95	108+57	RT	4.51
IL 57	106-95	107+12	LT	0.36
IL 57	107+80	108+57	LT	2.44
IL 57	109+42	110+28	LT	2.56
IL 57	109+42	109+75	RT	0.97
IL 57	110+28	110+63	RT	0.91
IL 57	110+93	111+01	LT	0.17
ROUNDED TOTAL				12

**IMPACT ATTENUATORS, TEMPORARY (FULLY REDIRECTIVE, NARROW), TEST LEVEL 3**

ALIGNMENT	FROM STATION	LT/RT	EACH
STAGE 1			
IL-57	107+77.56	LT	1
IL-57	110+02.41	LT	1
TOTAL			2

**IMPACT ATTENUATORS, RELOCATE (FULLY REDIRECTIVE, NARROW), TEST LEVEL 3**

ALIGNMENT	FROM STATION	LT/RT	EACH
STAGE 1			
IL-57	107+52.64	RT	1
IL-57	110+39.69	RT	1
TOTAL			2

**BASE COURSE WIDENING 9"**

ALIGNMENT	FROM STATION	TO STATION	LT/RT	AREA (SQ YD)
IL-57	106+95.54	111+00.69	LT	268.80
IL-57	106+95.54	110+63.30	RT	233.41
ROUNDED TOTAL				503

**SUBBASE GRANULAR MATERIAL, TYPE B 6"**

ALIGNMENT	FROM STATION	TO STATION	LT/RT	AREA (SQ YD)
IL-57	108+57.25	109+42.75	LT/RT	247.00
ROUNDED TOTAL				247

**PORTLAND CEMENT CONCRETE BASE COURSE 12"**

ALIGNMENT	FROM STATION	TO STATION	LT/RT	AREA (SQ YD)
IL-57	108+57.25	109+42.75	LT/RT	161.33
ROUNDED TOTAL				162

**AGGREGATE SHOULDERS, TYPE B, 8"**

ALIGNMENT	FROM STATION	TO STATION	LT/RT	AREA (SQ YD)
IL-57	108+57.25	109+42.75	RT	28.50
IL-57	108+57.25	109+42.75	LT	28.49
ROUNDED TOTAL				57

**PAVEMENT REMOVAL**

ALIGNMENT	FROM STATION	TO STATION	LT/RT	AREA (SQ YD)
IL-57	106+95.45	107+83.38	LT	57.80
IL-57	108+57.25	108+80.98	LT/RT	57.34
IL-57	109+12.94	109+42.75	LT/RT	71.73
IL-57	109+71.37	110+39.08	RT	40.97
IL-57	110+14.84	111+00.69	LT	56.29
ROUNDED TOTAL				285

**PAVED SHOULDER REMOVAL**

ALIGNMENT	FROM STATION	TO STATION	LT/RT	AREA (SQ YD)
IL-57	106+95.54	108+57.25	RT	41.68
IL-57	107+84.40	108+57.25	LT	19.27
IL-57	109+12.94	110+14.84	LT	24.91
IL-57	109+12.94	109+71.37	RT	12.99
IL-57	110+39.08	110+63.31	RT	4.86
ROUNDED TOTAL				104

MODEL: Sched 11  
 FILE NAME: E:\2031-4\CADD\_Sheets\0672\G18-Sched11.dgn



USER NAME = rober	DESIGNED - JK	REVISED -
	DRAWN - JK	REVISED -
PLOT SCALE = 0.16666667' / in.	CHECKED - RC	REVISED -
PLOT DATE = \$DATES	DATE - 11/2024	REVISED -

**STATE OF ILLINOIS  
DEPARTMENT OF TRANSPORTATION**

<b>IL RTE 57 OVER HARKNESS CREEK SCHEDULE OF QUANTITIES</b>	
SCALE: N.T.S.	SHEET 1 OF 2 SHEETS STA. TO STA.

F.A.P. RTE.	SECTION	COUNTY	TOTAL SHEETS	SHEET NO.
502	42BR	ADAMS	38	7
CONTRACT NO. 72G18				
ILLINOIS FED. AID PROJECT				

**TEMPORARY CONCRETE BARRIER**

ALIGNMENT	FROM STATION	TO STATION	LT/RT	FOOT
STAGE 1				
IL-57	107+77.56	110+02.41	LT	225.00
STAGE 2				
IL-57	107+52.64	110+39.69	RT	62.50
ROUNDED TOTAL				287.5

**RELOCATE TEMPORARY CONCRETE BARRIER**

ALIGNMENT	FROM STATION	TO STATION	LT/RT	FOOT
STAGE 2				
IL-57	107+52.64	110+39.69	RT	225.00
ROUNDED TOTAL				225.0

**RAISED REFLECTIVE PAVEMENT MARKER REMOVAL**

FROM STATION	TO STATION	LT/RT	EACH
108+57.25	109+42.75	LT/RT	3
TOTAL			3

**EARTHWORK SCHEDULE**

EARTH EXCAVATION	STRUCTURE EXCAVATION*	EARTH EXC. ADJ. FOR SHRINKAGE (15%)	EMBANKMENT	EARTHWORK BALANCE (+/-)
CU YD	CU YD	CU YD	CU YD	CU YD
35	925	816	420	396

\*COST OF STRUCTURE EXCAVATION INCLUDED IN THE COST OF PRECAST BOX CULVERT.

**GUARDRAIL REMOVAL**

FROM STATION	TO STATION	LT/RT	FOOT
107+78.25	108+81.42	RT	102.43
107+83.91	108+79.87	LT	95.98
109+13.21	109+78.22	RT	65.08
109+13.32	110+15.65	LT	102.49
ROUNDED TOTAL			366

**STEEL PLATE BEAM GUARDRAIL, TY A, 6' POSTS**

FROM STATION	TO STATION	LT/RT	FOOT
108+31.12	109+69.03	LT	137.50
ROUNDED TOTAL			137.5

**GUARDRAIL REFLECTORS, TYPE A**

FROM STATION	TO STATION	LT/RT	EACH
107+81.14	110+18.88	LT	4
TOTAL			4

**MODIFIED URETHANE PAVEMENT MARKING - LINE 5"**

ALIGNMENT	FROM STATION	TO STATION	LT/RT	TYPE	LENGTH	FACTOR	FOOT
IL-57	105+68.77	106+95.44	LT	5" SOLID WHITE	126.61	1.00	126.61
IL-57	105+68.77	111+88.66	LT/RT	5" SKIP DASH YELLOW	620.19	0.25	155.05
IL-57	105+68.77	109+74.85	RT	5" SOLID WHITE	406.73	1.00	406.73
IL-57	107+80.74	110+24.18	RT	5" SOLID WHITE	244.07	1.00	244.07
IL-57	110+38.92	111+88.66	RT	5" SOLID WHITE	149.93	1.00	149.93
IL-57	111+01.21	111+88.66	LT	5" SOLID WHITE	88.32	1.00	88.32
ROUNDED TOTAL							1,171

**PAVEMENT MARKING REMOVAL - GRINDING**

ALIGNMENT	FROM STATION	TO STATION	LT/RT	AREA (SQ FT)
IL-57	105+68.77	106+95.44	LT	52.75
IL-57	105+68.77	111+88.66	LT/RT	64.60
IL-57	105+68.77	109+74.85	RT	169.47
IL-57	107+80.74	110+24.18	RT	101.70
IL-57	110+38.92	111+88.66	RT	62.47
IL-57	111+01.21	111+88.66	LT	36.80
ROUNDED TOTAL				488

**TRAFFIC BARRIER TERMINAL, TYPE 1 (SPECIAL) TANGENT**

ALIGNMENT	FROM STATION	LT/RT	EACH
IL-57	107+81.12	LT	1
IL-57	110+18.84	LT	1
TOTAL			2

**TERMINAL MARKER-DIRECT APPLIED**

ALIGNMENT	FROM STATION	LT/RT	EACH
IL-57	107+81.12	LT	1
IL-57	110+18.84	LT	1
TOTAL			2

MODEL: Sched\_11\_2  
 FILE NAME: E:\2024\11\CADD\_Sheets\06718-Sched\_11\_2.dgn



USER NAME = r0ber	DESIGNED - JK	REVISED -
	DRAWN - JK	REVISED -
PLOT SCALE = 0.16666667 ' / in.	CHECKED - RC	REVISED -
PLOT DATE = \$DATES	DATE - 11/2024	REVISED -

**STATE OF ILLINOIS  
DEPARTMENT OF TRANSPORTATION**

<b>IL RTE 57 OVER HARKNESS CREEK SCHEDULE OF QUANTITIES</b>			
SCALE: N.T.S.	SHEET 2 OF 2 SHEETS	STA.	TO STA.

F.A.P. RTE.	SECTION	COUNTY	TOTAL SHEETS	SHEET NO.
502	42BR	ADAMS	38	8
CONTRACT NO. 72G18				
ILLINOIS FED. AID PROJECT				



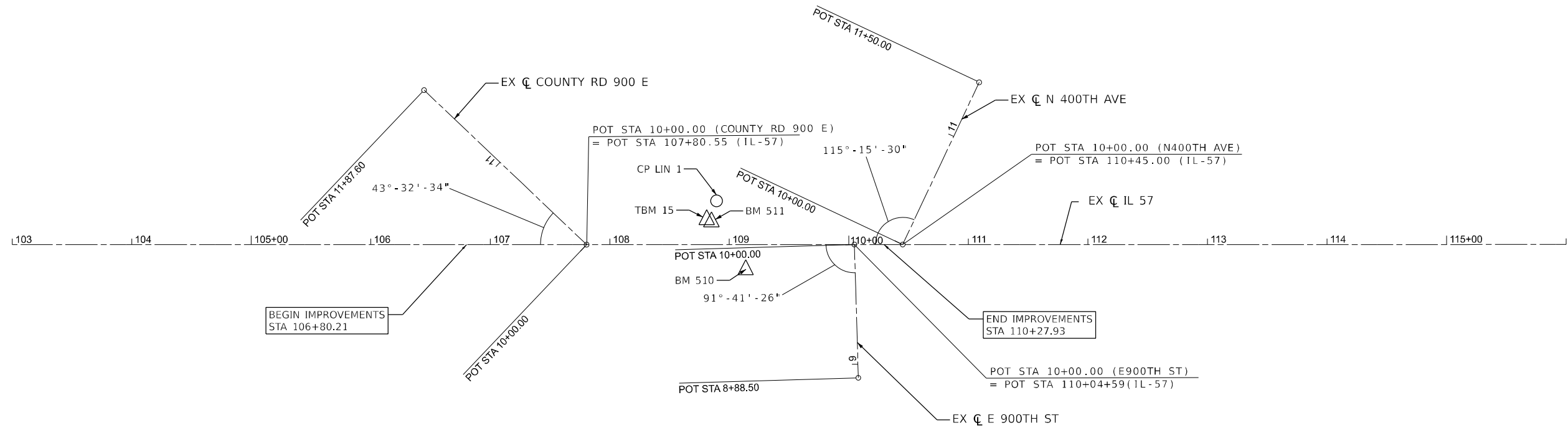
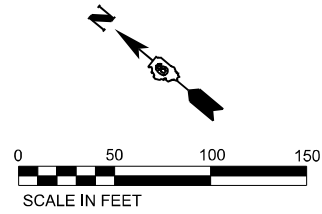

MODEL: E:\039 - RTE 01 (Sheet)  
 FILE NAME: E:\039 - CAD - Sheets\0572G16-1E.dwg



USER NAME = rober	DESIGNED - NH	REVISED -
DRAWN - NH	REVISED -	
PLOT SCALE = 0.1666667' / in.	CHECKED - RC	REVISED -
PLOT DATE = \$DATES	DATE - 11/2024	REVISED -

**STATE OF ILLINOIS  
 DEPARTMENT OF TRANSPORTATION**

**IL RTE 57 OVER HARKNESS CREEK  
 ALIGNMENT, TIES AND BENCHMARKS**

SCALE: 1"=50'      SHEET 1 OF 2 SHEETS      STA. 103+00.00 TO STA. 116+00.00

F.A.P. RTE.	SECTION	COUNTY	TOTAL SHEETS	SHEET NO.
57	42BR	ADAMS	38	9
CONTRACT NO. 72G18				
ILLINOIS FED. AID PROJECT				

ALIGNMENT CONTROL						
NAD83/2007 ADJ - STATE PLANE WEST ZONE						
POINT TYPE	STATION	NORTHING	EASTING	RADIUS	LENGTH	TANGENT
ALIGNMENT NAME: E003 IL-57						
POT	24+70.678	1155407.786	1961031.431			
PI	44+47.000	1154005.523	1962424.092			
PI	55+36.967	1153232.156	1963192.162			
PC	70+92.532	1152128.308	1964288.201			
PI	75+17.563	1151826.701	1964587.675	28804.42	850.00	425.03
PT	79+42.532	1151516.389	1964878.119			
PC	90+80.083	1150685.872	1965655.463			
PI	95+50.201	1150342.642	1965976.717	17118.64	940.00	470.12
PT	100+20.083	1149982.298	1966278.65			
PC	116+29.273	1148748.861	1967312.15			
PI	121+20.000	1148372.719	1967627.319	9586.60	980.60	490.73
PT	126+09.873	1147966.362	1967902.434			
PC	136+24.940	1147125.815	1968471.505			
PI	143+49.255	1146526.032	1968877.574	11445.42	1446.70	724.32
PT	150+71.640	1145982.224	1969356.014			
PI	160+00.000	1145285.221	1969969.234			
PC	173+16.707	1144296.651	1970838.973			
PI	178+68.084	1143882.683	1971203.181	6354.58	1100.00	551.38
PT	184+16.707	1143537.632	1971633.247			
POT	186+37.433	1143399.502	1971805.411			
POINT TYPE	STATION	NORTHING	EASTING	RADIUS	LENGTH	TANGENT
ALIGNMENT NAME: E900TH_STN						
POT	10+00.000	1149399.405	1966767.058			
POT	11+87.600	1149586.638	1966778.782			
POINT TYPE	STATION	NORTHING	EASTING	RADIUS	LENGTH	TANGENT
ALIGNMENT NAME: E900TH_STS						
POT	8+88.500	1149153.576	1966827.634			
POT	10+00.000	1149227.677	1966910.949			
POINT TYPE	STATION	NORTHING	EASTING	RADIUS	LENGTH	TANGENT
ALIGNMENT NAME: N400TH_AVE						
POT	10+00.000	1149196.707	1966936.899			
POT	11+50.000	1149234.774	1967081.888			

BENCHMARKS					
BENCHMARK	NAVD 88 DATUM ELEVATION IN FEET	DESCRIPTION	STATION	OFFSET	CHAIN
BM 512	504.42	CHSLD [ ] CENTER SW HDWL CULVERT UNDER IL57, 2.76 MILE NW FROM JCT W\ I-172	101+77.3	27.1 RT	E003
BM 511	509.673	CHSLD [ ] NE WINGWALL BRIDGE 001-0016, 2.61 MILE NW FROM JCT W\ I-172	108+81.2	20.8 LT	E003
TBM 21	512.318	CHSLD X TOP CONC HANDRAIL NE CORNER BRIDGE 001-0016, 2.61 MILE NW FROM JCT W\ I-172	108+84.9	19.4 LT	E003
BM 510	509.598	CHSLD [ ] SW WINGWALL BRIDGE 001-0016, 2.61 MILE NW FROM JCT W\ I-172	109+13.4	21.1 RT	E003

HORIZONTAL CONTROL STATIONS						
CONTROL POINT	NORTHING	EASTING	DESCRIPTION	STATION	OFFSET	CHAIN
NAD83/2007ADJ						
9925	1149855.842	1966411.708	TRAVERSE STATION	102+02.47	20.77 LT	E003
LIN 1	1149339.517	1966864.866	TRAVERSE STATION	108+89.27	36.24 LT	E003
5004	1140226.876	1966040.055	TRAVERSE STATION	110+23.90	21.80 LT	E003
9928	1148308.339	1967636.408	TRAVERSE STATION	121+76.56	18.80 RT	E003

MODEL: E:\003 - RTE 05 (Sheet)  
 FILE NAME: E:\003 - CAD - Sheets\0572G-16-11E.dwg



USER NAME = rober	DESIGNED - NH	REVISED -
PLOT SCALE = 0.16666667 / in.	DRAWN - NH	REVISED -
PLOT DATE = \$DATES	CHECKED - RC	REVISED -
	DATE - 11/2024	REVISED -

**STATE OF ILLINOIS  
 DEPARTMENT OF TRANSPORTATION**

<b>IL RTE 57 OVER HARKNESS CREEK          ALIGNMENT, TIES AND BENCHMARKS</b>			
SCALE: N.T.S.	SHEET 2	OF 2 SHEETS	STA. TO STA.

F.A.P. RTE.	SECTION	COUNTY	TOTAL SHEETS	SHEET NO.
57	42BR	ADAMS	38	10
CONTRACT NO. 72G18				
ILLINOIS FED. AID PROJECT				

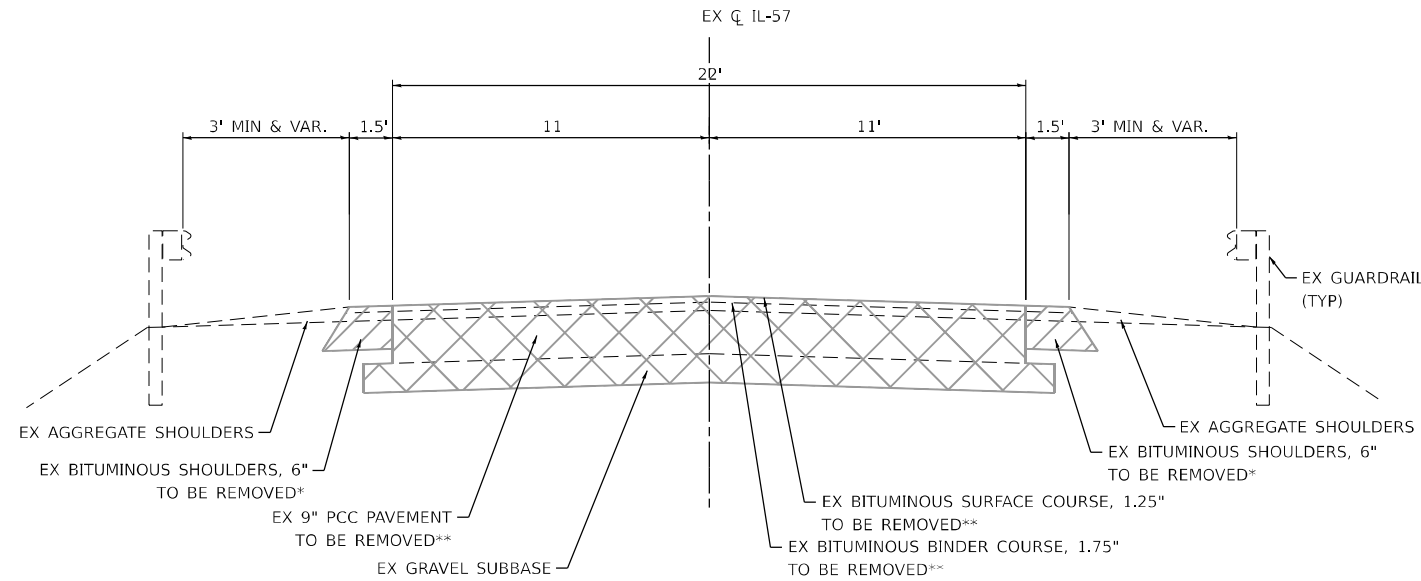

**EXISTING ROADWAY TYPICAL SECTION**

IL RTE 57: STA 106+95.54 TO STA 111+00.69  
 STRUCTURE OMISSION  
 STA 108+80.98 TO STA 109+12.73

\*LIMITS OF PAVED SHOULDER REMOVAL:  
 STA 106+95.54 RT TO STA 108+80.98 RT  
 STA 109+12.73 RT TO STA 110+63.30 RT  
 STA 106+95.54 LT TO STA 108+80.98 LT  
 STA 109+12.73 LT TO STA 111+00.69 LT

\*\*LIMITS OF PAVEMENT REMOVAL:  
 STA 108+57.25 TO STA 108+80.98  
 STA 109+12.73 TO STA 109+42.75

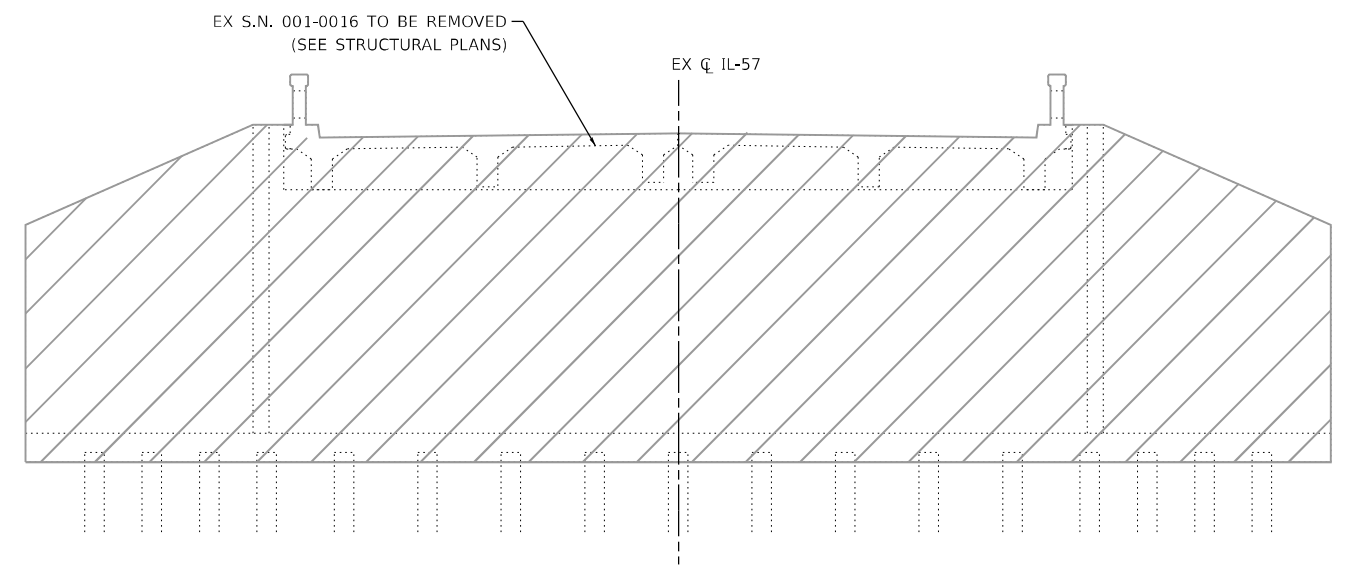

**EXISTING ROADWAY TYPICAL SECTION**

SN 001-0016  
 STA 108+80.98 TO STA 109+12.73

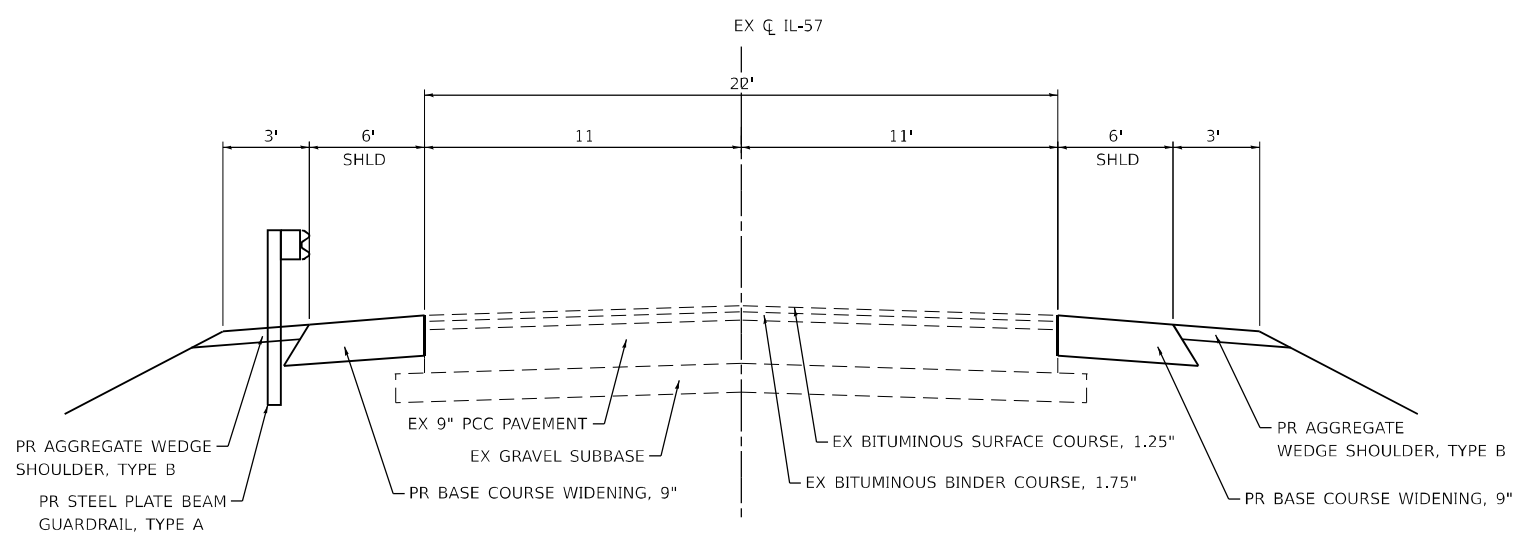

**PROPOSED ROADWAY TYPICAL SECTION**

IL RTE 57: STA 106+95.54 TO STA 111+00.69  
 STRUCTURE OMISSION  
 STA 108+57.25 TO STA 109+42.75

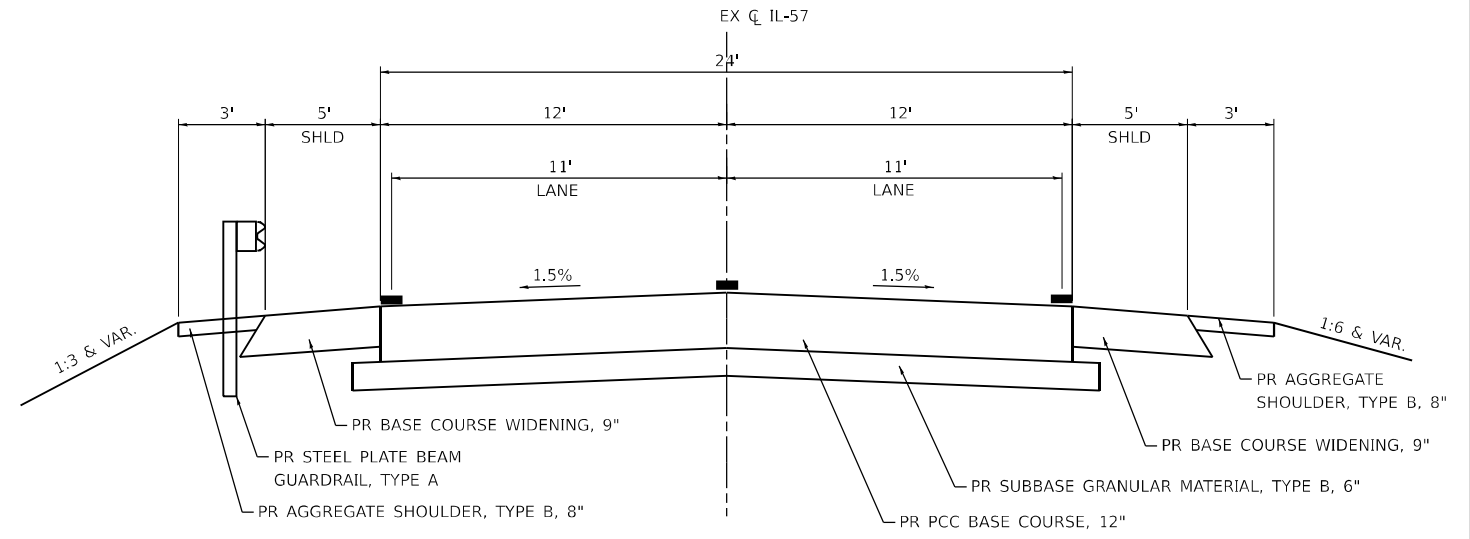

**PROPOSED ROADWAY TYPICAL SECTION**

IL RTE 57 OVER HARKNESS CREEK (AT SN 001-2503)  
 LOOKING EAST  
 STA 108+57.25 TO STA 109+42.75

MODEL: T:\projects\01\_Sheet1  
 FILE NAME: E:\2021-1\CADD\_Sheets\067218-Typical Sections.dgn



USER NAME = rober	DESIGNED - JK	REVISED -
PLOT SCALE = 0.16666667 1/ in.	DRAWN - JK	REVISED -
PLOT DATE = \$DATES	CHECKED - RC	REVISED -
	DATE - 11/2024	REVISED -

STATE OF ILLINOIS  
 DEPARTMENT OF TRANSPORTATION

IL RTE 57 OVER HARKNESS CREEK TYPICAL SECTIONS		F.A.P. RTE.	SECTION	COUNTY	TOTAL SHEETS	SHEET NO.
SCALE: N.T.S.		502	42BR	ADAMS	38	11
SHEET 1 OF 1 SHEETS		CONTRACT NO. 72G18		ILLINOIS FED. AID PROJECT		

**MAINTENANCE OR TRAFFIC GENERAL NOTES**

1. EXISTING PAVEMENT MARKINGS THAT CONFLICT WITH TEMPORARY MARKINGS SHALL BE REMOVED. THIS WORK WILL BE PAID FOR AT THE CONTRACT UNIT PRICE PER SQUARE FOOT FOR PAVEMENT MARKING REMOVAL - GRINDING.
2. SEE STRUCTURAL PLANS FOR CULVERT INSTALLATION INFORMATION.
3. THE CONTRACTOR SHALL CONTRACT THE DISTRICT 6 TRAFFIC CONTROL SECTION OF THE BUREAU OF OPERATIONS AT (217) 785-5306 AT LEAST 21 DAYS PRIOR TO IMPLEMENTING PRESTAGE TRAFFIC CONTROL AND A MINIMUM OF 48 HOURS PRIOR TO A SWITCH IN TRAFFIC STAGING.
4. ROAD CLOSED AND WARNING SIGNS AND TYPE III BARRICADES ON THE NORTH AND SOUTH LEGS OF E 900TH ST INCLUDED IN COST OF BLR 21 STANDARD.

**SUGGESTED SEQUENCE OF OPERATIONS**

PRE-STAGE

1. INSTALL TEMPORARY TRAFFIC CONTROL DEVICES, TEMPORARY SIGNAGE & TEMPORARY PAVEMENT MARKINGS TO CLOSE BOTH THE NB & SB IL-57 OUTSIDE SHOULDER UTILIZING HIGHWAY STANDARD 701326.
2. REMOVE PAVED SHOULDER ALONG THE OUTSIDE OF NB & SB IL-57 AS SHOWN ON THE REMOVAL PLANS.
3. CONSTRUCT PROPOSED BASE COURSE WIDENING ALONG THE OUTSIDE OF NB & SB IL-57 AT LOCATIONS SHOWN IN THE ROADWAY PLANS.

STAGE 1

1. INSTALL TEMPORARY TRAFFIC CONTROL DEVICES, TEMPORARY SIGNAGE & TEMPORARY PAVEMENT MARKINGS TO CLOSE THE NB LANE OF IL 57 AS SHOWN IN THE STAGE 1 STAGING PLANS OR AS DIRECTED BY THE ENGINEER AND ACTIVATE TEMPORARY BRIDGE SIGNALS.
2. REMOVE THE STAGE 1 PORTION OF THE EXISTING STRUCTURE AS SHOWN ON THE STRUCTURE PLANS.
3. CONSTRUCT THE STAGE 1 PORTION OF THE PROPOSED CULVERT AND PROPOSED PAVEMENT AS SHOWN ON THE ROADWAY AND STRUCTURE PLANS.
4. CONSTRUCT THE REMAINING PORTION OF THE PAVED SHOULDER ALONG THE OUTSIDE OF NB IL-57 WITHIN THE LIMITS OF THE EXISTING STRUCTURE THAT WAS REMOVED AT THE LOCATIONS SHOWN IN THE STAGE 1 STAGING & ROADWAY PLANS.

STAGE 2

1. INSTALL TEMPORARY TRAFFIC CONTROL DEVICES, TEMPORARY SIGNAGE & TEMPORARY PAVEMENT MARKINGS TO CLOSE THE SB LANE OF IL 57 AS SHOWN IN THE STAGE 2 STAGING PLANS OR AS DIRECTED BY THE ENGINEER.
2. REMOVE THE STAGE 2 PORTION OF THE EXISTING STRUCTURE AS SHOWN ON THE STRUCTURE PLANS.
3. CONSTRUCT THE STAGE 2 PORTION OF THE PROPOSED CULVERT AND PROPOSED PAVEMENT & BUTT JOINTS AS SHOWN ON THE ROADWAY AND STRUCTURE PLANS.
4. CONSTRUCT THE REMAINING PORTION OF THE PAVED SHOULDER ALONG THE OUTSIDE OF SB IL-57 WITHIN THE LIMITS OF THE EXISTING STRUCTURE THAT WAS REMOVED AT THE LOCATIONS SHOWN IN THE STAGE 2 STAGING & ROADWAY PLANS.

MODEL: T:\proj\14\01\_Sheet1  
 FILE NAME: E:\2021-14\CADD\_Sheets\067218-NOT-00.dgn



USER NAME = r0ber	DESIGNED - JK	REVISED -
	DRAWN - JK	REVISED -
PLOT SCALE = 0.16666667 ' / in.	CHECKED - RC	REVISED -
PLOT DATE = \$DATES	DATE - 11/2024	REVISED -

**STATE OF ILLINOIS  
DEPARTMENT OF TRANSPORTATION**

**IL RTE 57 OVER HARKNESS CREEK  
STAGING GENERAL NOTES & SUGGESTED SEQUENCE**

SCALE: N.T.S. SHEET 1 OF 4 SHEETS STA. TO STA.

F.A.P. RTE.	SECTION	COUNTY	TOTAL SHEETS	SHEET NO.
502	42BR	ADAMS	38	12
CONTRACT NO. 72G18				
			ILLINOIS	FED. AID PROJECT

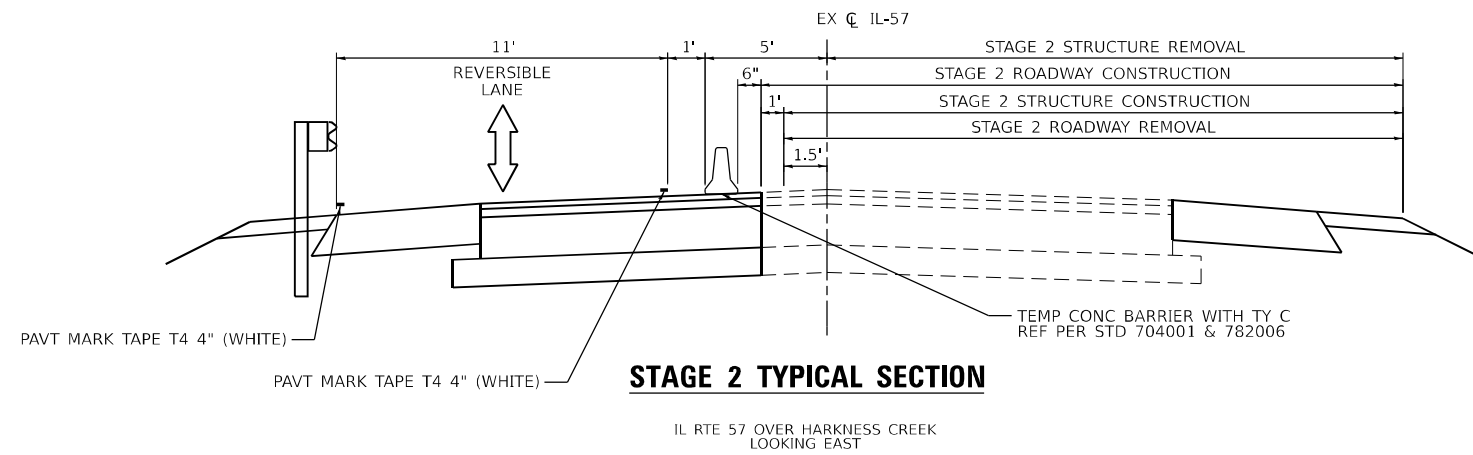
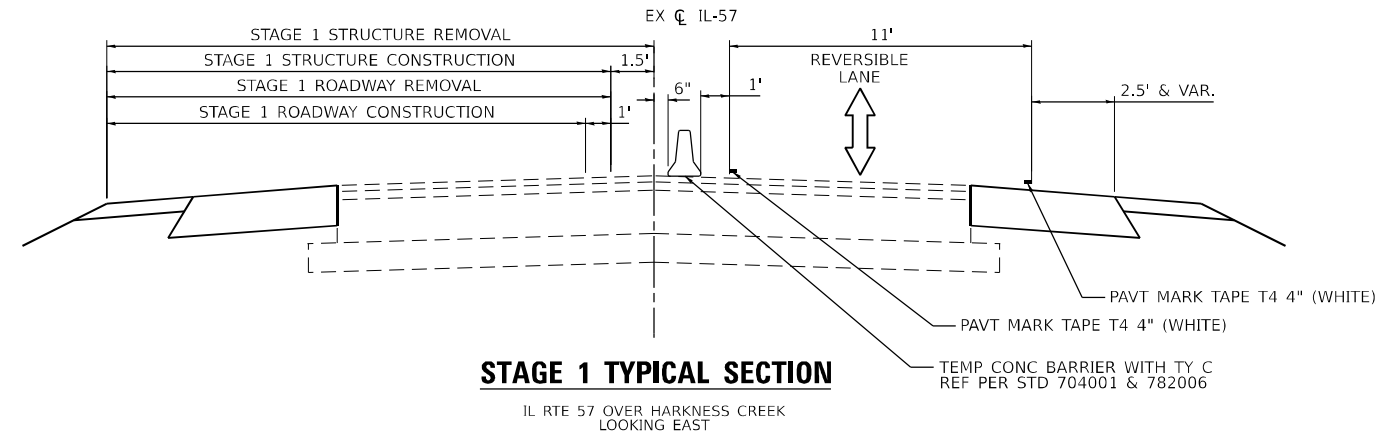

MODEL: T:\proj\10115\sheet1  
 FILE NAME: E:\2024\CADD\_Sheets\067218\MOT-hyprefcs.dgn

USER NAME = r0ber	DESIGNED - JK	REVISED -
	DRAWN - JK	REVISED -
PLOT SCALE = 0.16666667 1/ in.	CHECKED - RC	REVISED -
PLOT DATE = \$DATES	DATE - 11/2024	REVISED -

**STATE OF ILLINOIS  
DEPARTMENT OF TRANSPORTATION**







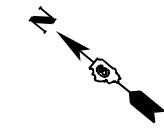

**IL RTE 57 OVER HARKNESS CREEK  
STAGING TYPICAL SECTIONS**

SCALE: N.T.S. SHEET 2 OF 4 SHEETS STA. TO STA.

F.A.P. RTE.	SECTION	COUNTY	TOTAL SHEETS	SHEET NO.
502	42BR	ADAMS	38	13
CONTRACT NO. 72G18				
ILLINOIS FED. AID PROJECT				



**LEGEND**

-  WORK ZONE
-  DIRECTION OF TRAFFIC
-  IMPACT ATTENUATOR, TEMPORARY (FULLY REDIRECTIVE, NARROW) TEST LEVEL 3
-  TEMPORARY CONCRETE BARRIER
-  SIGN
-  TYPE III BARRICADE W/ FLASHING LIGHTS
-  DRUM WITH STEADY BURNING BI-DIRECTIONAL LIGHT
-  TRAFFIC SIGNAL
-  TEMPORARY RUMBLE STRIPS

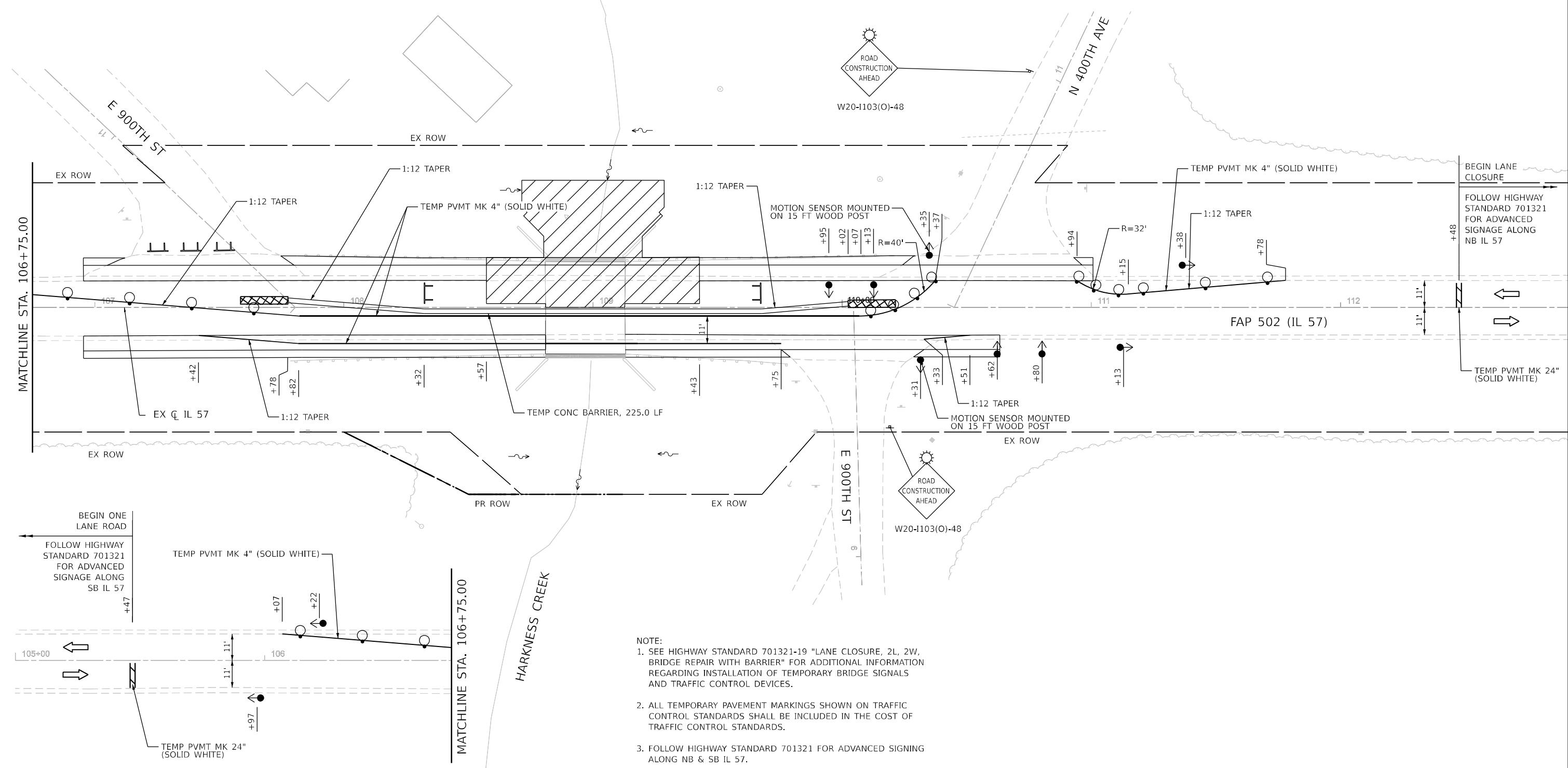

- NOTE:**
1. SEE HIGHWAY STANDARD 701321-19 "LANE CLOSURE, 2L, 2W, BRIDGE REPAIR WITH BARRIER" FOR ADDITIONAL INFORMATION REGARDING INSTALLATION OF TEMPORARY BRIDGE SIGNALS AND TRAFFIC CONTROL DEVICES.
  2. ALL TEMPORARY PAVEMENT MARKINGS SHOWN ON TRAFFIC CONTROL STANDARDS SHALL BE INCLUDED IN THE COST OF TRAFFIC CONTROL STANDARDS.
  3. FOLLOW HIGHWAY STANDARD 701321 FOR ADVANCED SIGNING ALONG NB & SB IL 57.

MODEL: EX4 - Plan 1 [Sheet]  
 FILE NAME: E:\2031-ACADD\_Sheets\06720318-Removal.dgn



USER NAME = 14nho	DESIGNED - JK	REVISED -
DRAWN - JK	REVISIONS -	
PLOT SCALE = 0.16666667 / in.	CHECKED - RC	REVISIONS -
PLOT DATE = 9/19/2024	DATE - 11/2024	REVISIONS -









**STATE OF ILLINOIS  
DEPARTMENT OF TRANSPORTATION**

**IL RTE 57 OVER HARKNESS CREEK  
STAGING PLAN - STAGE 1**

SCALE: 1"=20'      SHEET 3 OF 4 SHEETS      STA. 105+60.44 TO STA. 111+80.70

F.A.P. RTE.	SECTION	COUNTY	TOTAL SHEETS	SHEET NO.
502	42BR	ADAMS	38	14
CONTRACT NO. 72G18				
ILLINOIS FED. AID PROJECT				

**LEGEND**

-  WORK ZONE
-  DIRECTION OF TRAFFIC
-  IMPACT ATTENUATOR, TEMPORARY (FULLY REDIRECTIVE, NARROW) TEST LEVEL 3
-  TEMPORARY CONCRETE BARRIER
-  SIGN
-  TYPE III BARRICADE W/ FLASHING LIGHTS
-  DRUM WITH STEADY BURNING BI-DIRECTIONAL LIGHT
-  TRAFFIC SIGNAL
-  TEMPORARY RUMBLE STRIPS

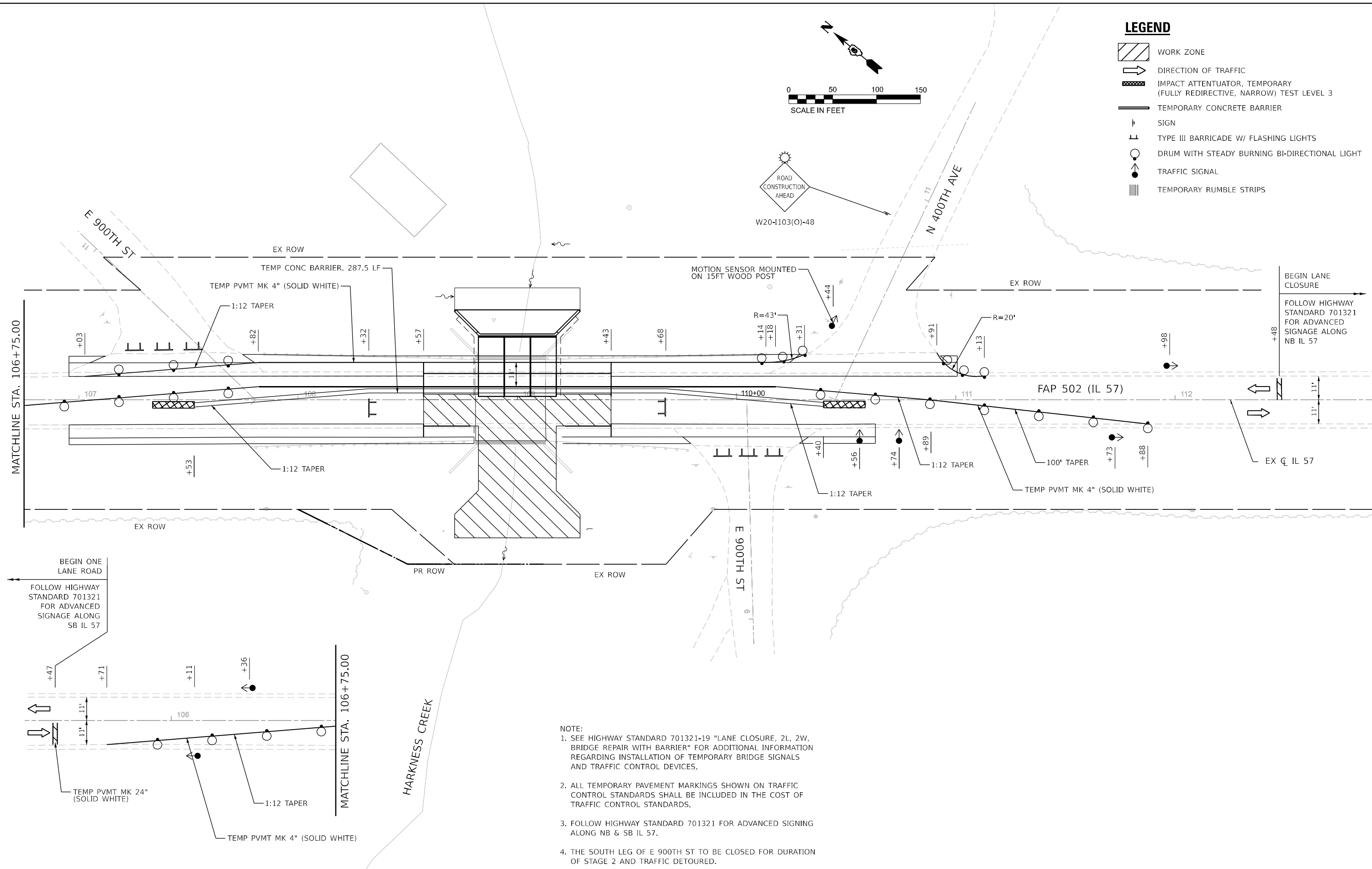
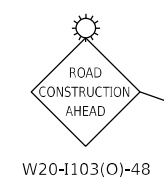

- NOTE:
1. SEE HIGHWAY STANDARD 701321-19 "LANE CLOSURE, 2L, 2W, BRIDGE REPAIR WITH BARRIER" FOR ADDITIONAL INFORMATION REGARDING INSTALLATION OF TEMPORARY BRIDGE SIGNALS AND TRAFFIC CONTROL DEVICES.
  2. ALL TEMPORARY PAVEMENT MARKINGS SHOWN ON TRAFFIC CONTROL STANDARDS SHALL BE INCLUDED IN THE COST OF TRAFFIC CONTROL STANDARDS.
  3. FOLLOW HIGHWAY STANDARD 701321 FOR ADVANCED SIGNING ALONG NB & SB IL 57.
  4. THE SOUTH LEG OF E 900TH ST TO BE CLOSED FOR DURATION OF STAGE 2 AND TRAFFIC DETOURED.

MODEL: EX4 - Plan 1 [Sheet]  
 FILE NAME: E:\2031-ICADD\_Sheets\2031-8-Removal.dgn

**LIN ENGINEERING, LTD.**  
 Consulting Engineers  
 Westmont, Illinois

USER NAME = 14nho	DESIGNED - JK	REVISED -
DRAWN - JK	REVISED -	
PLOT SCALE = 0.1666667 / in.	CHECKED - RC	REVISED -
PLOT DATE = 9/19/2024	DATE - 11/2024	REVISED -

**STATE OF ILLINOIS  
 DEPARTMENT OF TRANSPORTATION**

**IL RTE 57 OVER HARKNESS CREEK  
 STAGING PLAN - STAGE 2**

SCALE: 1"=20'

SHEET 4 OF 4 SHEETS

STA. 105+58.77 TO STA. 112+76.47

F.A.P. RTE.	SECTION	COUNTY	TOTAL SHEETS	SHEET NO.
502	42BR	ADAMS	38	15
CONTRACT NO. 72G18				
ILLINOIS FED. AID PROJECT				

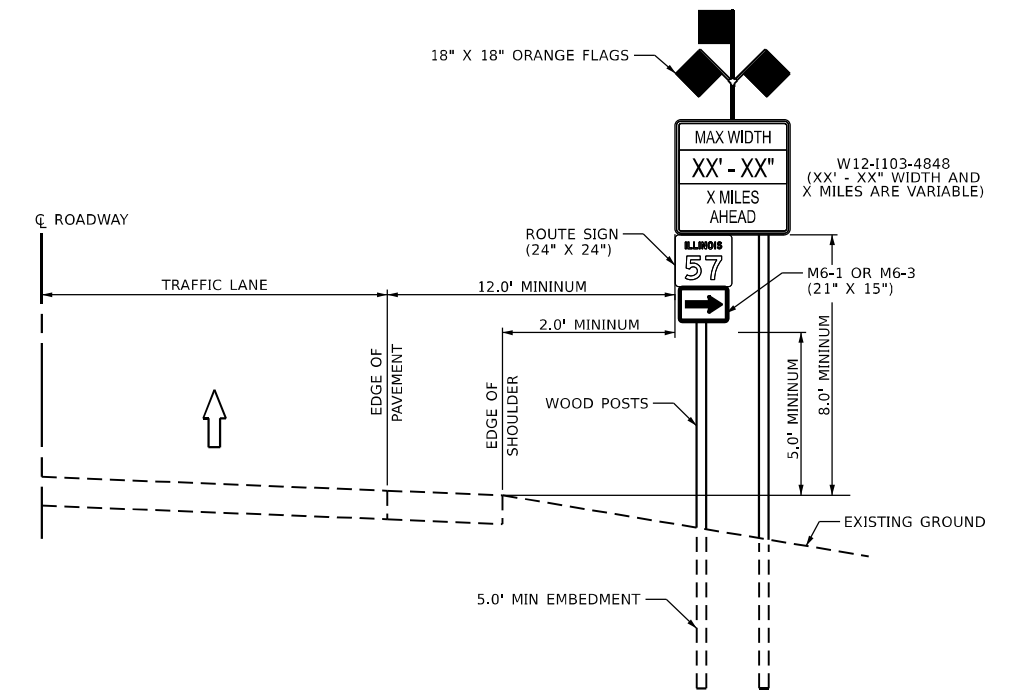
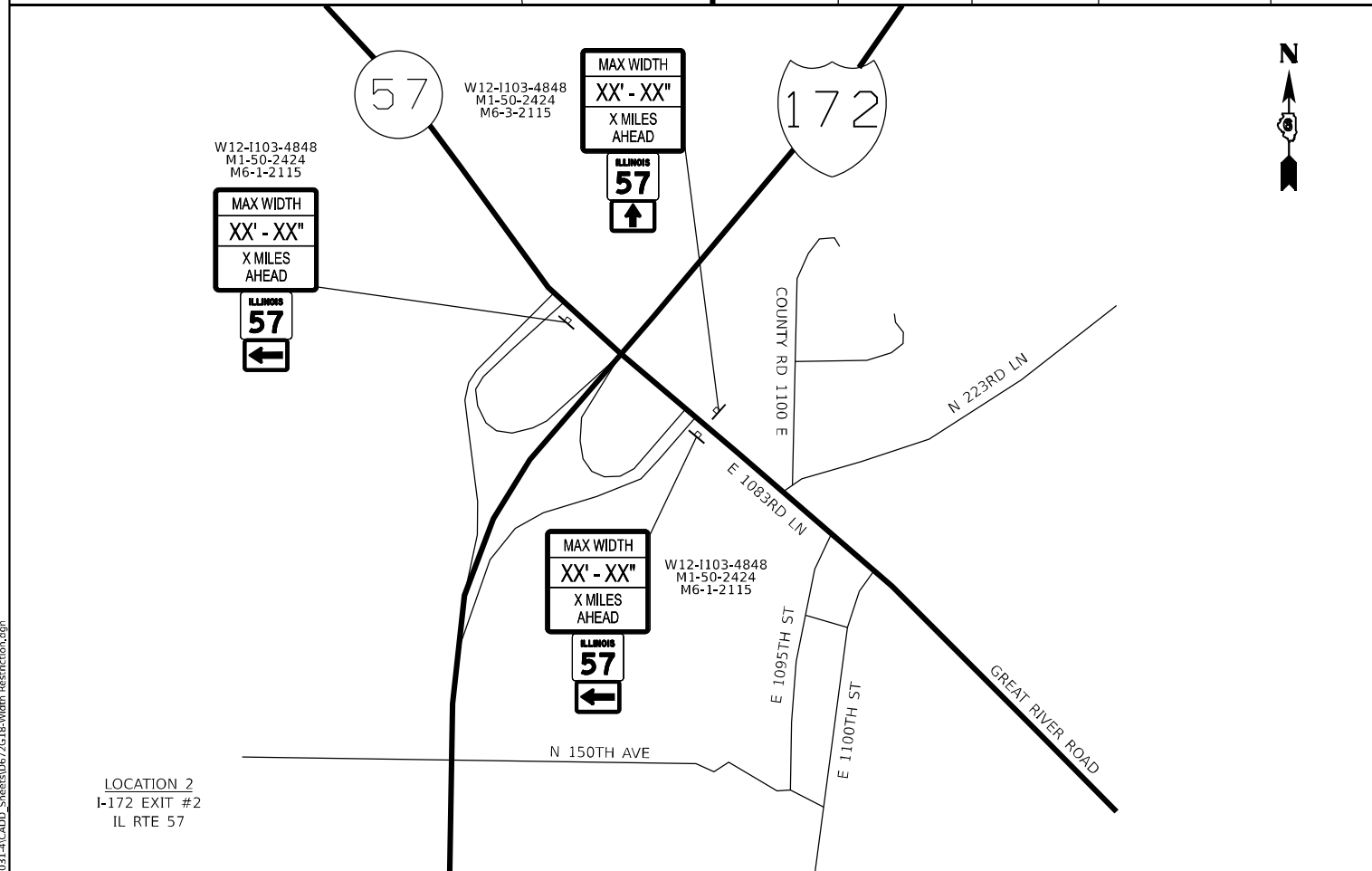
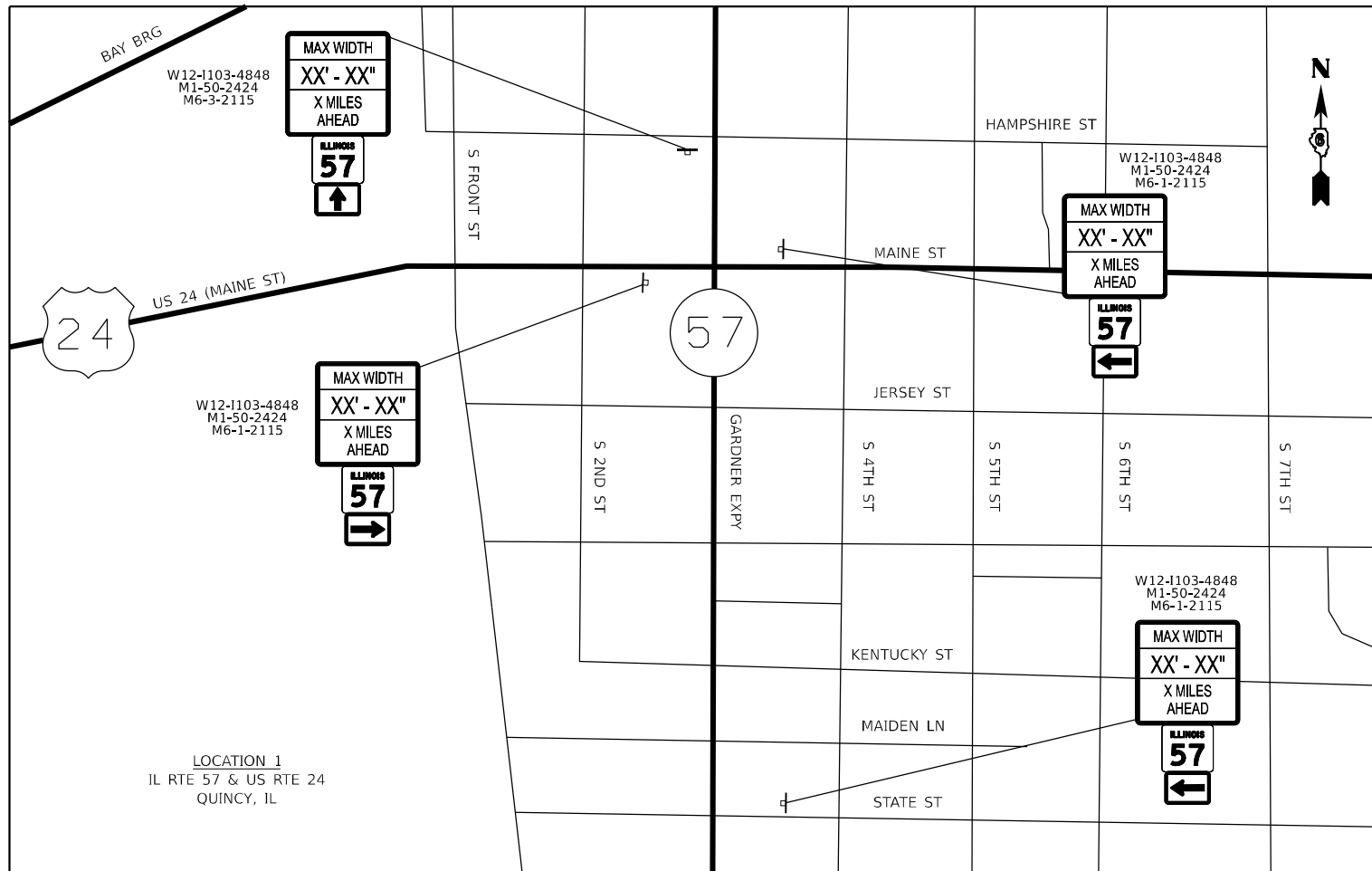

**WIDTH RESTRICTION SIGN  
CONVENTIONAL ROADWAYS**

MODEL: T:\projects\01\_Sheets\1  
 FILE NAME: E:\2023\11\CADD\_Sheets\0672\G18-Width\_Restriction.dgn

**LIN ENGINEERING, LTD.**  
 Consulting Engineers  
 Westmont, Illinois

USER NAME = r0ber	DESIGNED - JK	REVISED -
PLOT SCALE = 0.16666667 1/ in.	DRAWN - JK	REVISED -
PLOT DATE = \$DATES	CHECKED - RC	REVISED -
	DATE - 11/2024	REVISED -

**STATE OF ILLINOIS  
DEPARTMENT OF TRANSPORTATION**



<b>IL RTE 57 OVER HARKNESS CREEK WIDTH RESTRICTION SIGNING DETAIL</b>	
SCALE: N.T.S.	TO STA.
SHEET 1 OF 1 SHEETS	STA. TO STA.

F.A.P. RTE. 502	SECTION 42BR	COUNTY ADAMS	TOTAL SHEETS 38	SHEET NO. 16
CONTRACT NO. 72G18				
ILLINOIS FED. AID PROJECT				

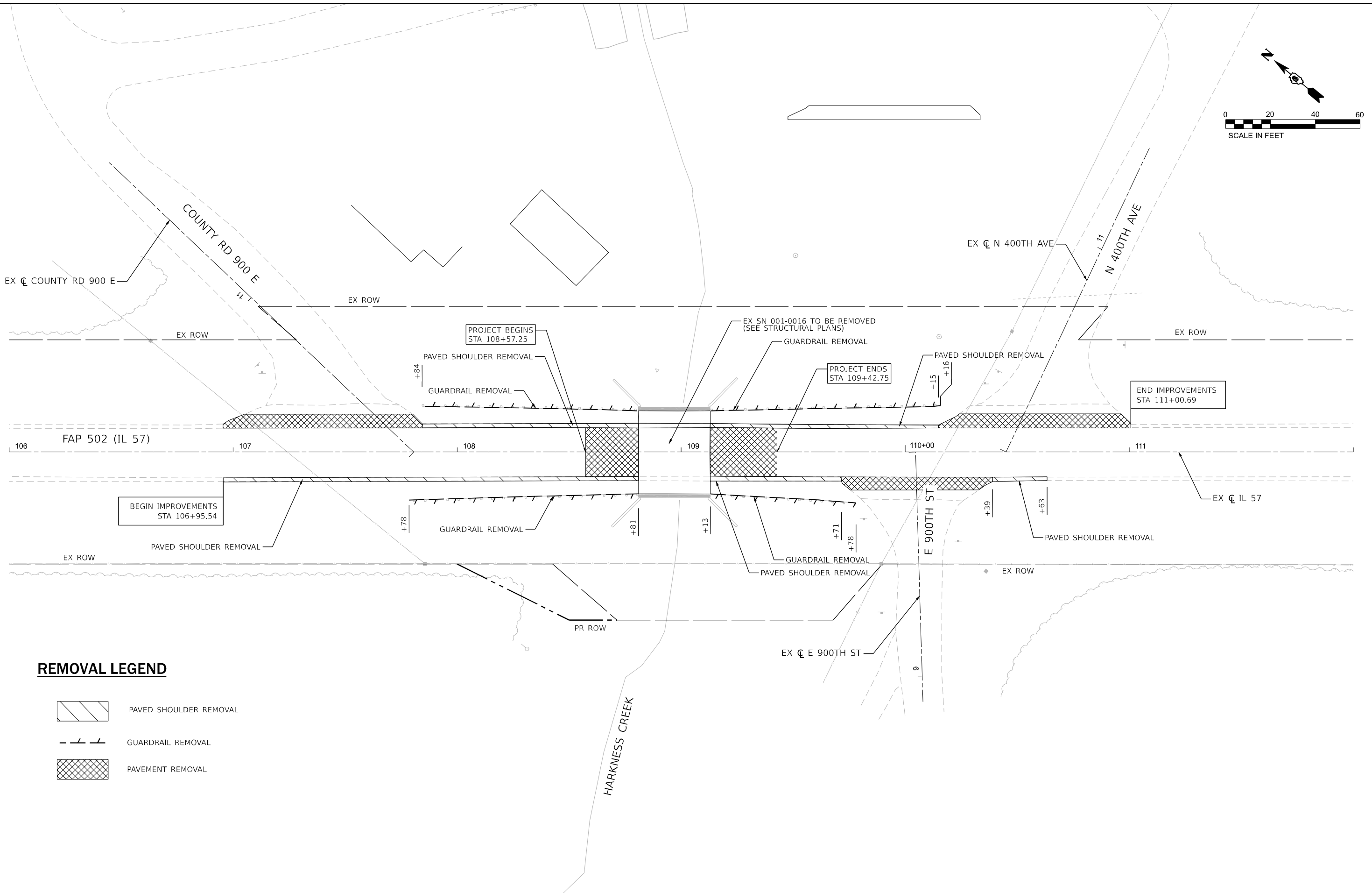
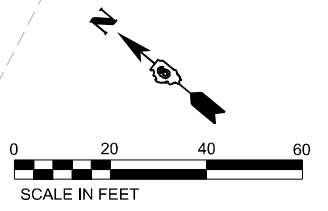

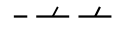

**REMOVAL LEGEND**

-  PAVED SHOULDER REMOVAL
-  GUARDRAIL REMOVAL
-  PAVEMENT REMOVAL

MODEL: EX4 - Plan 1 [Sheet]  
 FILE NAME: E:\2031-ICADD\_Sheets\2031-8-Removal.dgn

**LE** LIN ENGINEERING, LTD.  
 Consulting Engineers  
 Westmont, Illinois

USER NAME = jkehr	DESIGNED - NH	REVISED -
	DRAWN - NH	REVISED -
PLOT SCALE = 0.1666667' / in.	CHECKED - RC	REVISED -
PLOT DATE = 11/14/2024	DATE - 11/2024	REVISED -

**STATE OF ILLINOIS  
 DEPARTMENT OF TRANSPORTATION**

**IL RTE 57 OVER HARKNESS CREEK  
 REMOVAL PLAN**

SCALE: 1"=20'    SHEET 1 OF 1 SHEETS    STA. 106+80.21 TO STA. 110+27.93

F.A.P. RTE. 502	SECTION 42BR	COUNTY ADAMS	TOTAL SHEETS 38	SHEET NO. 17
CONTRACT NO. 72G18				
ILLINOIS FED. AID PROJECT				

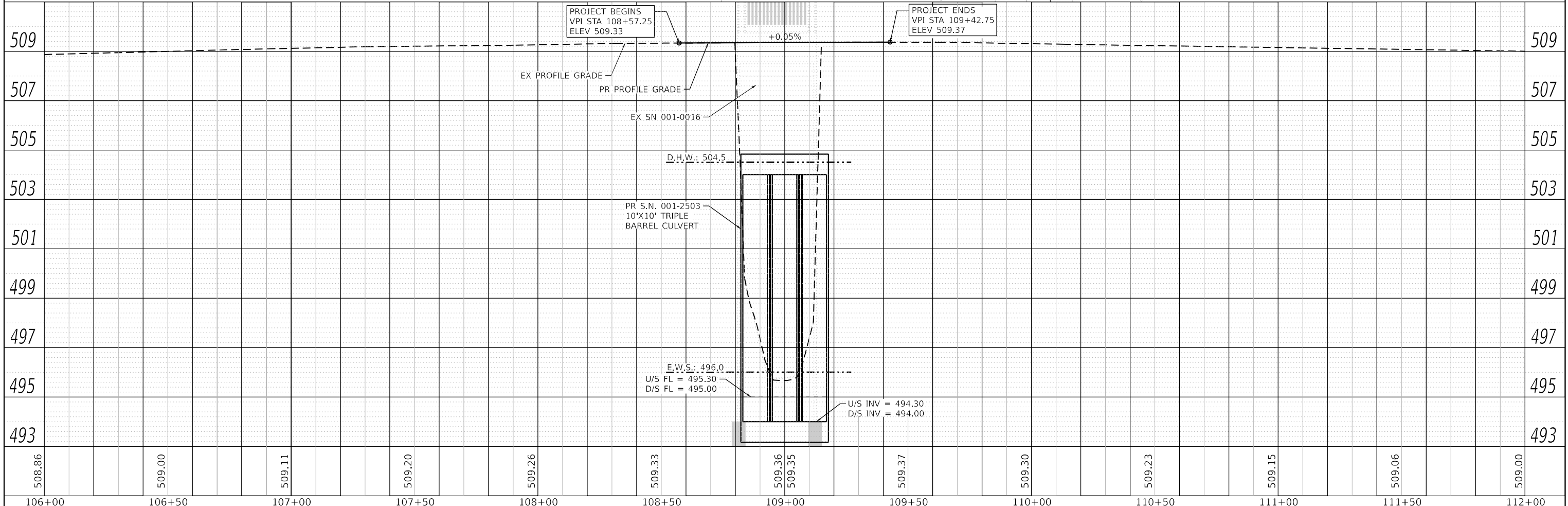
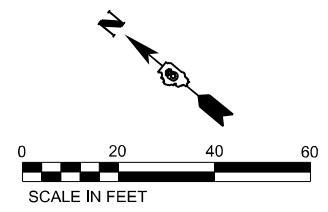
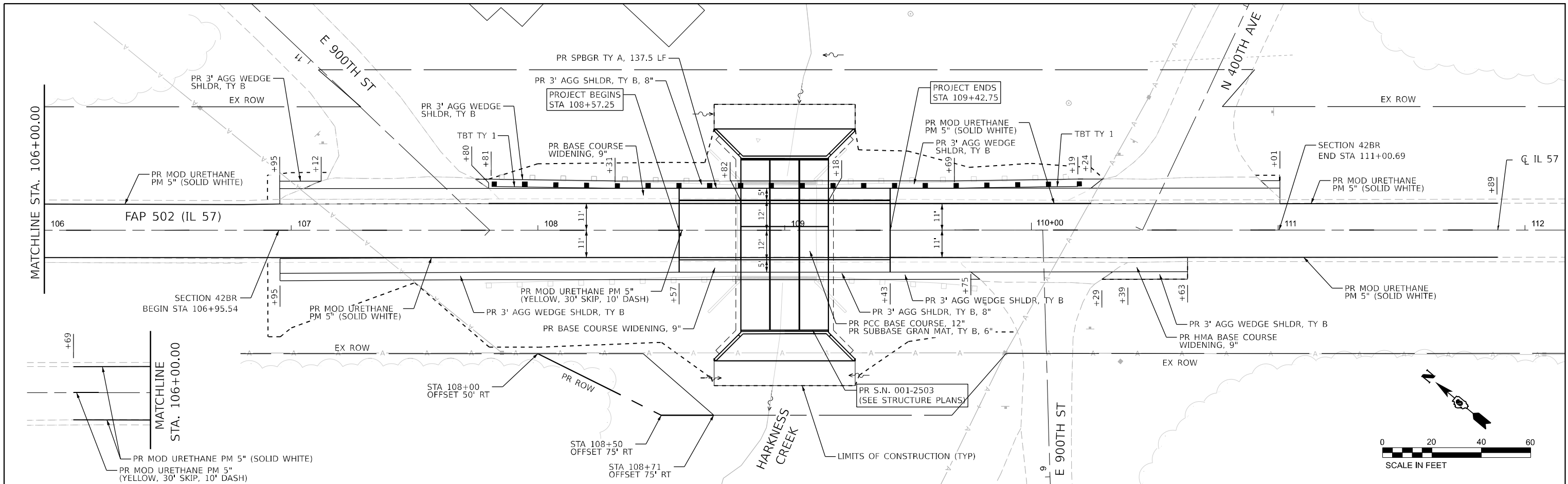

508.86	509.00	509.11	509.20	509.26	509.33	509.36 509.35	509.37	509.30	509.23	509.15	509.06	509.00
106+00	106+50	107+00	107+50	108+00	108+50	109+00	109+50	110+00	110+50	111+00	111+50	112+00

**LIN ENGINEERING, LTD.**  
Consulting Engineers  
Westmont, Illinois

USER NAME = rober	DESIGNED - JK	REVISED -
PLOT SCALE = 0.1666667' / in.	DRAWN - JK	REVISED -
PLOT DATE = \$DATE\$	CHECKED - RC	REVISED -
	DATE - 11/2024	REVISED -

**STATE OF ILLINOIS  
DEPARTMENT OF TRANSPORTATION**



**IL RTE 57 OVER HARKNESS CREEK  
PLAN & PROFILE**

SCALE: 1"=20' SHEET 1 OF 1 SHEETS STA. 106+80.21 TO STA. 110+27.93

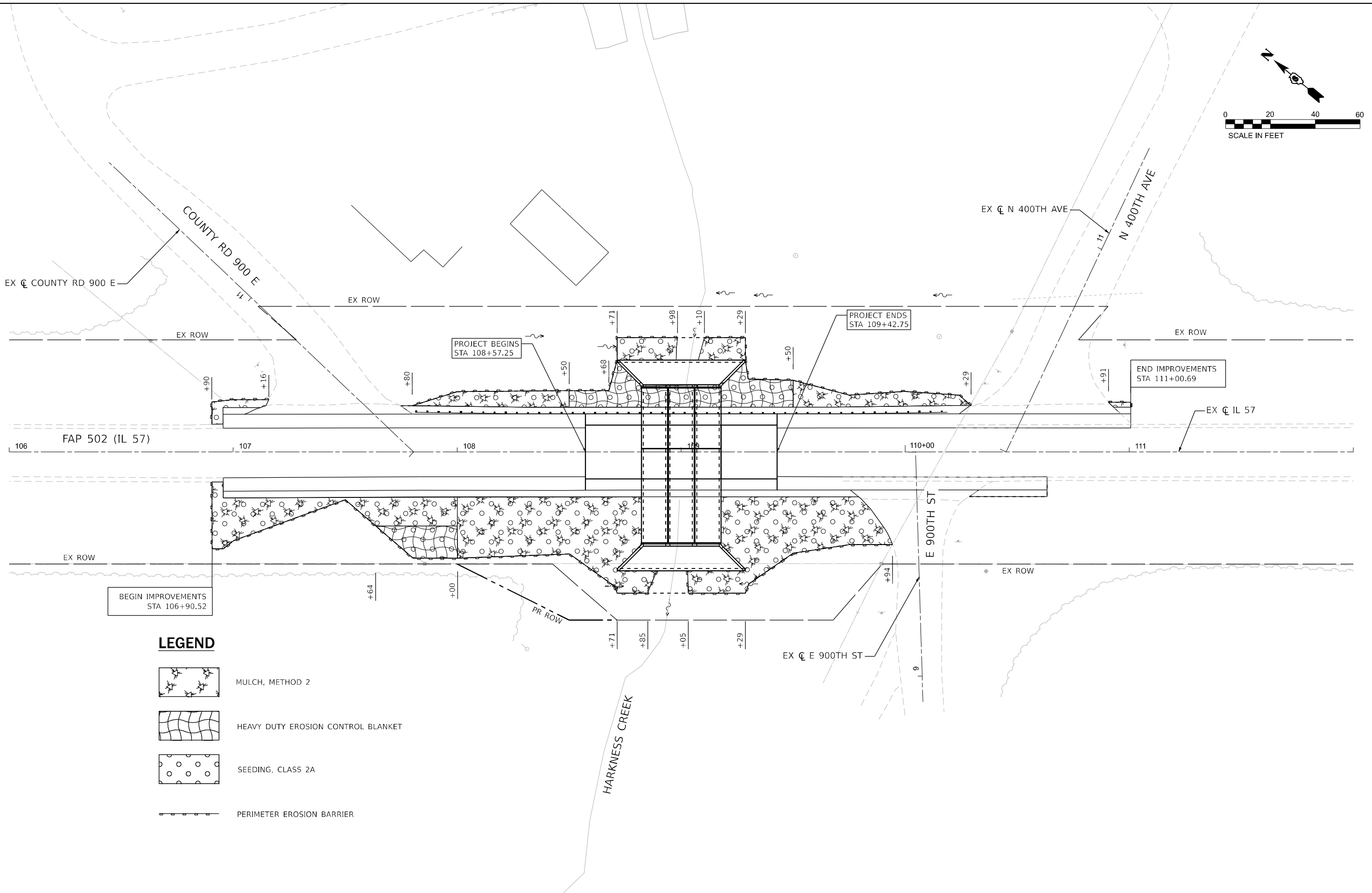
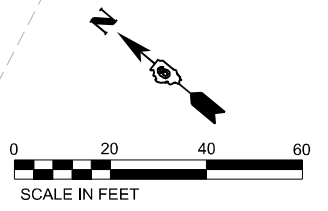
F.A.P. RTE. 502	SECTION 42BR	COUNTY ADAMS	TOTAL SHEETS 38	SHEET NO. 18
CONTRACT NO. 72G18			ILLINOIS FED. AID PROJECT	

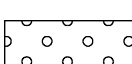
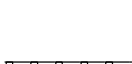

**LEGEND**

-  MULCH, METHOD 2
-  HEAVY DUTY EROSION CONTROL BLANKET
-  SEEDING, CLASS 2A
-  PERIMETER EROSION BARRIER

MODEL: EX4 - Plan 1 [Sheet]  
FILE NAME: E:\2031-ICADD\_Sheets\2031-8-Erosion\_Control.dgn

**Lin Engineering, Ltd.**  
Consulting Engineers  
Westmont, Illinois

USER NAME = jkehr	DESIGNED - NH	REVISED -
	DRAWN - NH	REVISED -
PLOT SCALE = 0.1666667' / in.	CHECKED - RC	REVISED -
PLOT DATE = 11/14/2024	DATE - 11/2024	REVISED -

**STATE OF ILLINOIS  
DEPARTMENT OF TRANSPORTATION**

**IL RTE 57 OVER HARKNESS CREEK  
EROSION CONTROL PLAN**

SCALE: 1"=20'    SHEET 1 OF 1 SHEETS    STA. 106+80.21 TO STA. 110+27.93

F.A.P. RTE.	SECTION	COUNTY	TOTAL SHEETS	SHEET NO.
502	42BR	ADAMS	38	19
CONTRACT NO. 72G18				
ILLINOIS FED. AID PROJECT				

Benchmark 510: Chiseled square on southwest wingwall of bridge, Sta. 109+13.4, 21.1' Rt., Elev. 509.598.

Existing Structure: SN 001-0016, built in 1941 under FA Rte.36, Section 42-B. The existing structure is a single span bridge with a reinforced concrete T-beam superstructure. The closed abutments are restrained top and bottom, supported on timber piles. The structure measures 32'-0" back to back abutments and 40'-4" out to out with no skew.

Work to be performed under staged construction.

No Slavage.

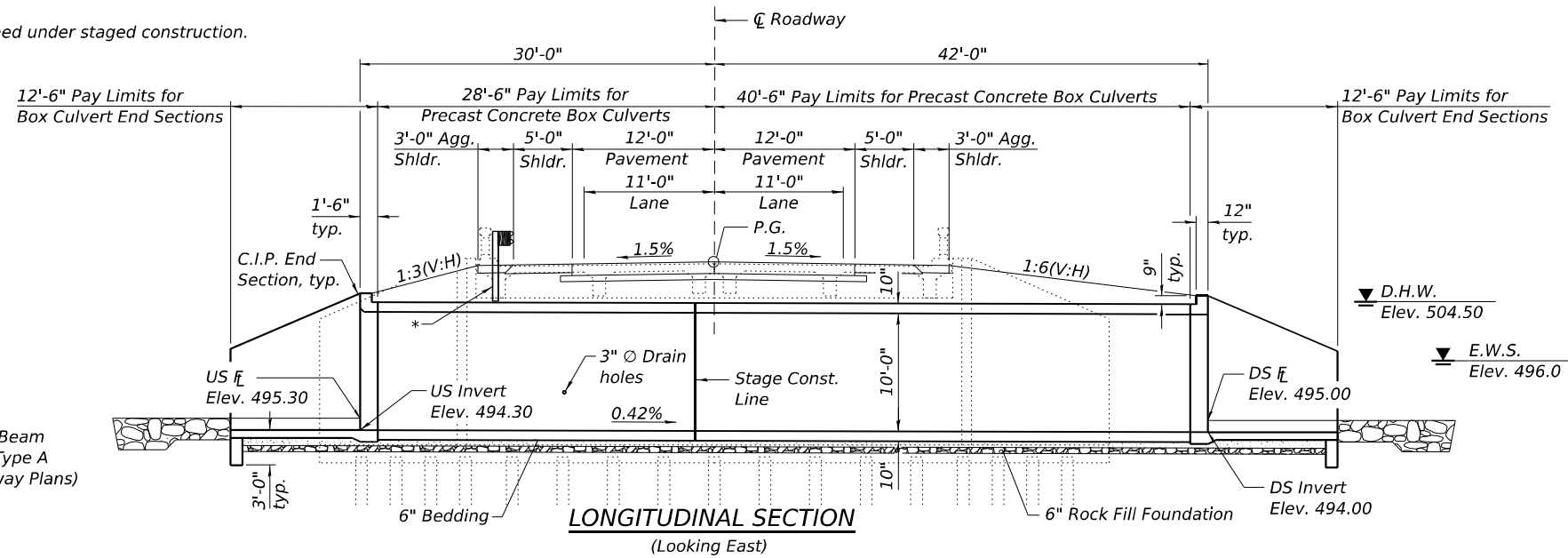

\* Steel Plate Beam Guardrail, Type A (See Roadway Plans)

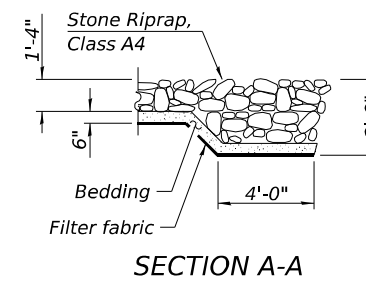

**INDEX OF SHEETS**

1. General Plan And Elevation
2. General Data
3. Stage Construction Details
4. Temporary Concrete Barrier
5. Box Culvert End Section Details
7. Soil Boring Log

**LOADING HL-93**

Allow 50#/sq. ft. for future wearing surface.

**DESIGN SPECIFICATIONS**

2020 AASHTO LRFD Bridge Design Specifications, 9th Edition

**DESIGN STRESSES**

**PRECAST UNITS**

f'c = 5,000 psi  
fy = 65,000 psi (Welded Wire Reinforcement)

**FIELD UNITS**

f'c = 3,500 psi  
fy = 60,000 psi (Reinforcement)

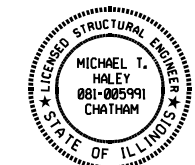

Michael T. Haley  
Licensed Structural Engineer  
State of Illinois No. 081-005991  
Expires 11/30/2024

12/16/2024  
Date

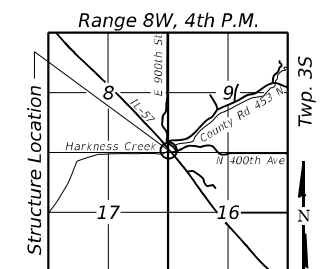
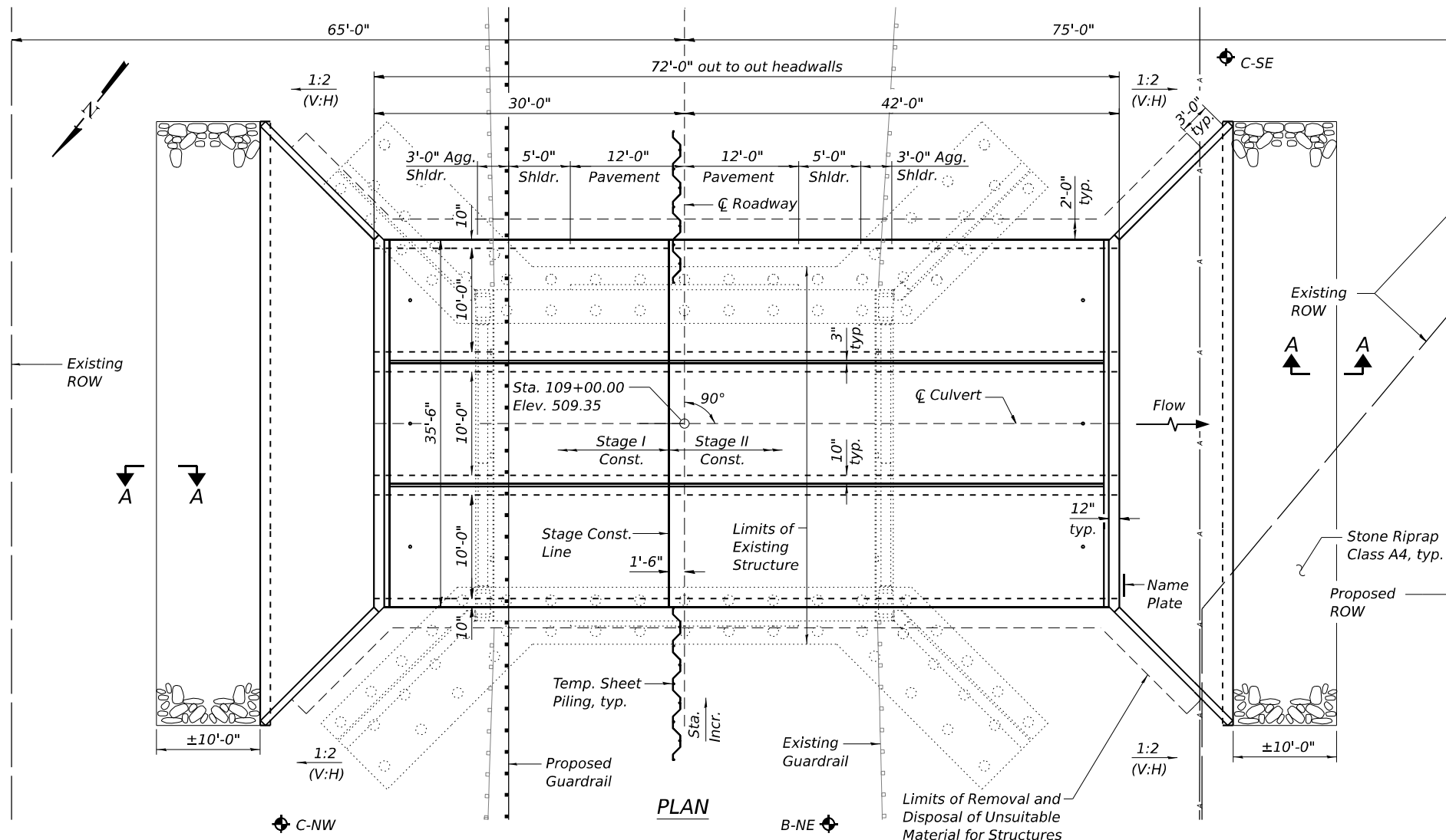

**GENERAL PLAN AND ELEVATION**

IL 57 OVER HARKNESS CREEK

F.A.P. RTE. 502 SEC. 42BR

ADAMS COUNTY

STATION 109+00.00

S.N. 001-2503

MODEL: D:\proj\12172024\12172024\Structural\Final Design\CADD (OR)\CADD\_Sheets\011011615725154-01-151.dgn  
FILE NAME: E:\2023\12172024\Structural\Final Design\CADD (OR)\CADD\_Sheets\011011615725154-01-151.dgn

**LE** LIN ENGINEERING, LTD.  
Consulting Engineers  
Springfield, Illinois

USER NAME = Ljh10-PC	DESIGNED - CZ	REVISED -
PLOT SCALE = 0:2,00000 "/> <td>CHECKED - CL</td> <td>REVISED -</td>	CHECKED - CL	REVISED -
PLOT DATE = 12/17/2024	DRAWN - SJH	REVISED -
	CHECKED - CL	REVISED -

STATE OF ILLINOIS  
DEPARTMENT OF TRANSPORTATION

SHEET 1 OF 7 SHEETS

F.A.P. RTE.	SECTION	COUNTY	TOTAL SHEETS	SHEET NO.
502	42BR	ADAMS	38	20
CONTRACT NO. 72G18				

ILLINOIS FED. AID PROJECT

**GENERAL NOTES**

- The design fill height for this box is 4.4ft. The precast box culvert sections shall conform to the requirements of ASTM C 1577.
- Drain holes shall be provided on exterior culvert walls for each precast box segment with a clear rise greater than 3 ft. The drain hole shall be located within 1/3 of the clear rise of the box culvert, shall not intercept the haunch, and shall conform to the requirements of Article 503.11 of the Standard Specification.
- Nonwoven geotextile fabric shall conform to the requirements of Art. 1080.01 of the Standard Specifications. The minimum weight of the fabric shall be 6 ounces per square yard.
- Precast concrete box culverts and cast-in-place box culvert end sections shall be backfilled with Granular Culvert Backfill in the required excavation areas on the sides of the box culvert from the top of the box culvert to the bottom of the box culvert. This area is included in the Granular Culvert Backfill pay item. The 6-inch thick layer of porous granular material required under the precast concrete box culvert, according to Section 540.06 of the standard specifications, shall also apply to the end sections. Cost of this porous granular material will not be paid for separately but shall be included in the unit price of the work for which it is required.
- Layout of the slope protection system may be varied to suit ground conditions in the field as directed by the engineer.
- Excavate behind the existing abutment prior to superstructure removal.
- Existing structure to be completely removed within 2 feet of proposed culvert barrel and end section footprint.
- The limits and quantities of removal and replacement of unsuitable material shown are based on the boring data and may be modified by the District Geotechnical and Field Engineers for variable subsurface conditions encountered in the field.

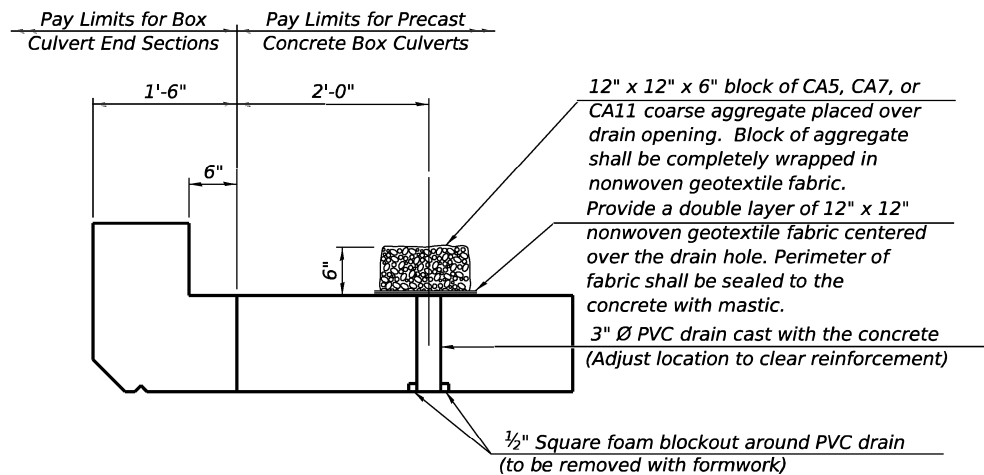

**DRAIN DETAIL**

(All costs associated with furnishing and constructing the above drain detail will not be measured for payment but shall be included in the contract unit price for the associated work.)

**TOTAL BILL OF MATERIAL**

ITEM	UNIT	TOTAL
Removal of Existing Structures	Each	1
Name Plates	Each	1
Box Culvert End Sections, Culvert No. 1	Each	2
Precast Concrete Box Culverts, 10'x10'	Foot	207
Granular Culvert Backfill	Cu. Yd.	326
Removal and Disposal of Unsuitable Materials for Structures	Cu. Yd.	145
Rock Fill - Foundation	Ton	132
Temporary Sheet Piling	Sq. Ft.	725
Stone Riprap, Class A4	Sq. Yd.	130
Filter Fabric	Sq. Yd.	135
Geotextile Retaining Wall	Sq. Ft.	138

**WATERWAY INFORMATION**

Flood Event	Freq. Yr.	Q C.F.S.	Opening Ft <sup>2</sup>		Nat. H.W.E.	Head - Ft.		Headwater El.	
			Exist.	Prop.		Exist.	Prop.	Exist.	Prop.
Ten - Year	10	932	169	221	502.6	0.2	0.0	502.8	502.6
Design	50	1,513	226	270	504.5	0.8	0.2	505.3	504.7
Base	100	1,779	241	270	505.0	1.2	0.5	506.2	505.5
Overtop Exist.	200	2,025	250	270	505.3	1.5	0.7	506.8	506.0
Max. Calc.	500	2,321	265	270	505.8	2.1	0.8	507.9	506.6

10 yr. average velocity from existing structure = 5.5 fps  
10 yr. outlet velocity from proposed structure = 4.0 fps

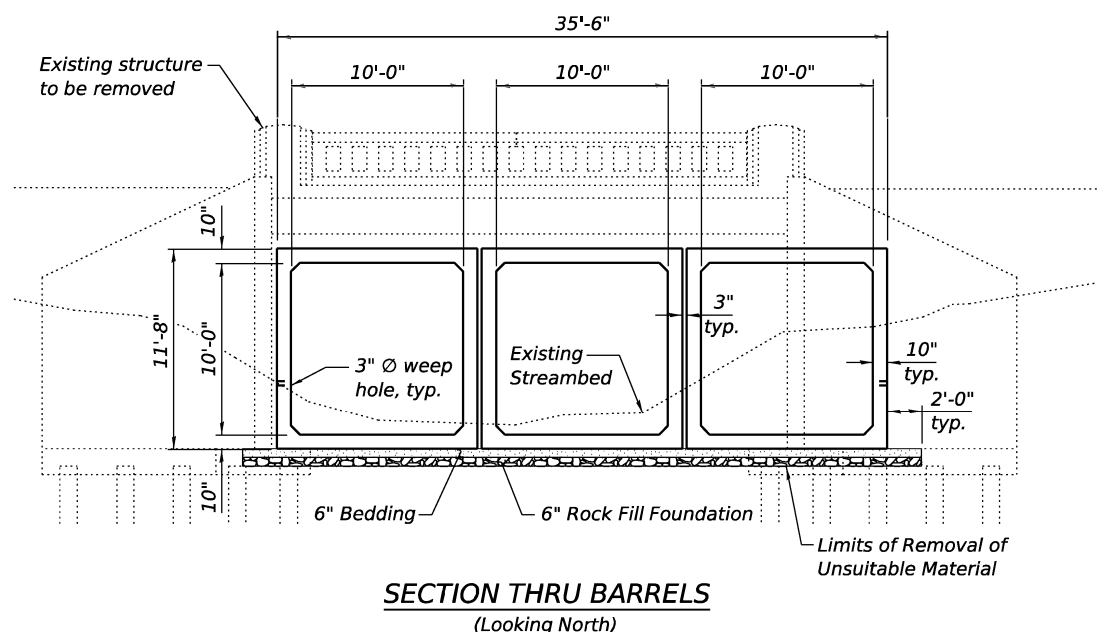

**SECTION THRU BARRELS**  
(Looking North)

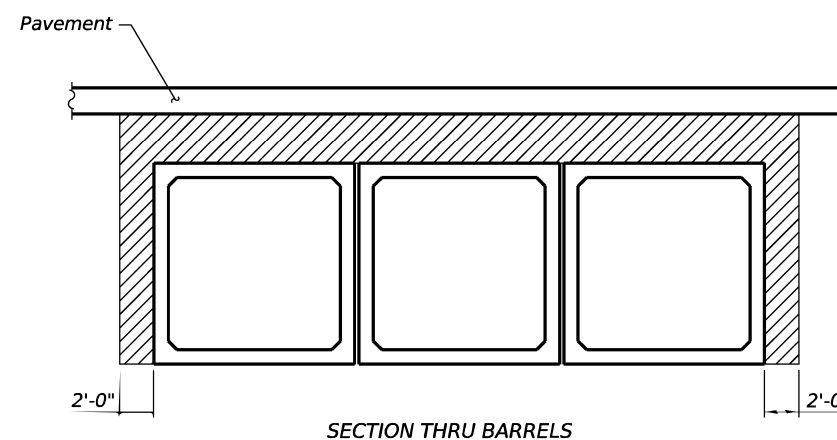

**SECTION THRU BARRELS**

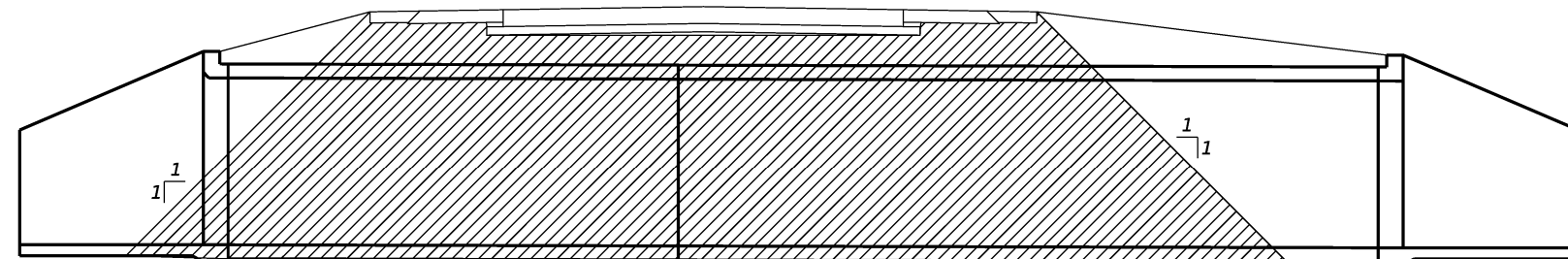

**LONGITUDINAL SECTION**

**PAY LIMITS FOR GRANULAR CULVERT BACKFILL**  
(Hatched area)

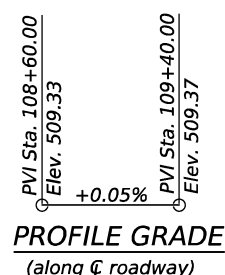

**PROFILE GRADE**  
(along centerline roadway)

STA. 109+00.00  
BUILT BY  
STATE OF ILLINOIS  
F.A.P. RTE.502 SECTION 42BR  
LOADING HL-93  
STR. NO. 001-2503

**NAME PLATE**  
See Std. 515001

MODEL: Design  
FILE NAME: E:\2021\Structure\Final Design\CADD\_Sheets\01\01\16-27\0114-002-CorData.dgn

**LE** LIN ENGINEERING, LTD.  
Consulting Engineers  
Springfield, Illinois

USER NAME = Lin10-PC	DESIGNED - CZ	REVISED -
PLOT SCALE = 0:2.00000" = 1"	CHECKED - CL	REVISED -
PLOT DATE = 12/17/2024	DRAWN - SJH	REVISED -
	CHECKED - CL	REVISED -

**STATE OF ILLINOIS**  
**DEPARTMENT OF TRANSPORTATION**

**GENERAL DATA**  
**STRUCTURE NO. 001-2503**

SHEET 2 OF 7 SHEETS

F.A.P. RTE.	SECTION	COUNTY	TOTAL SHEETS	SHEET NO.
502	42BR	ADAMS	38	21

CONTRACT NO. 72G18  
ILLINOIS FED. AID PROJECT

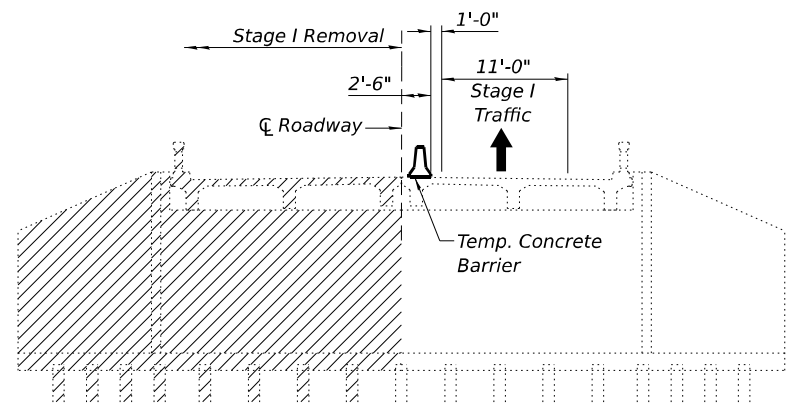

**STAGE I REMOVAL**

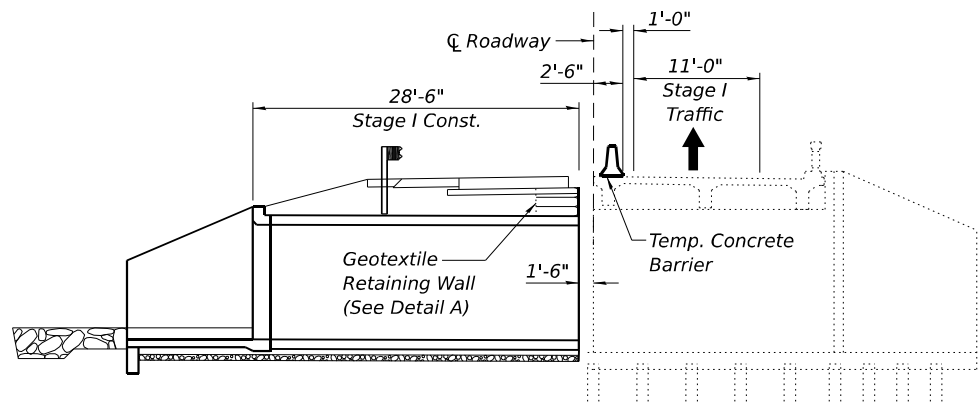

**STAGE I CONSTRUCTION**

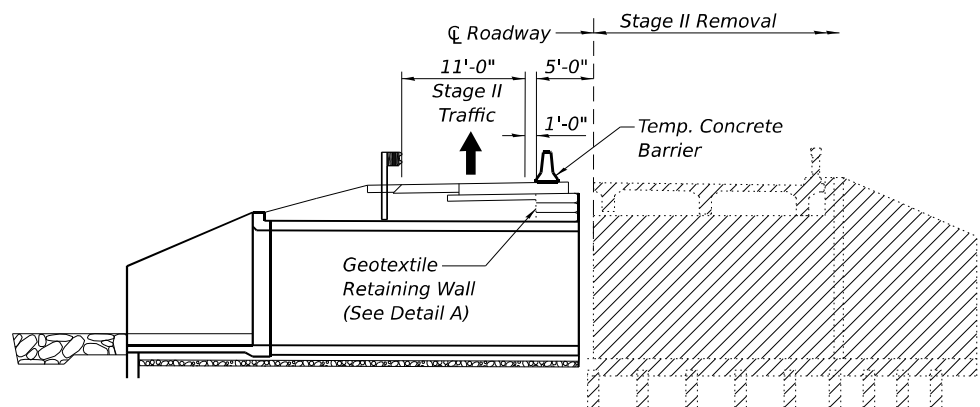

**STAGE II REMOVAL**

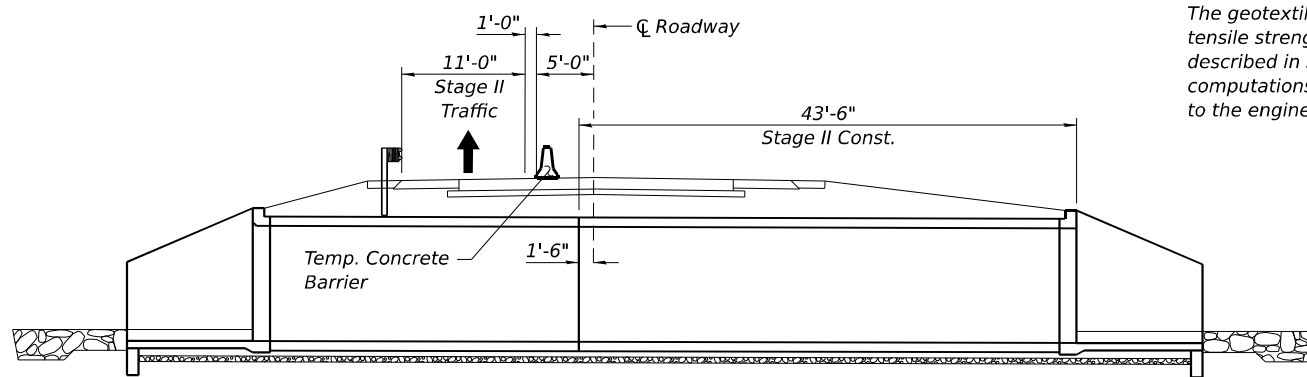

**STAGE II CONSTRUCTION**

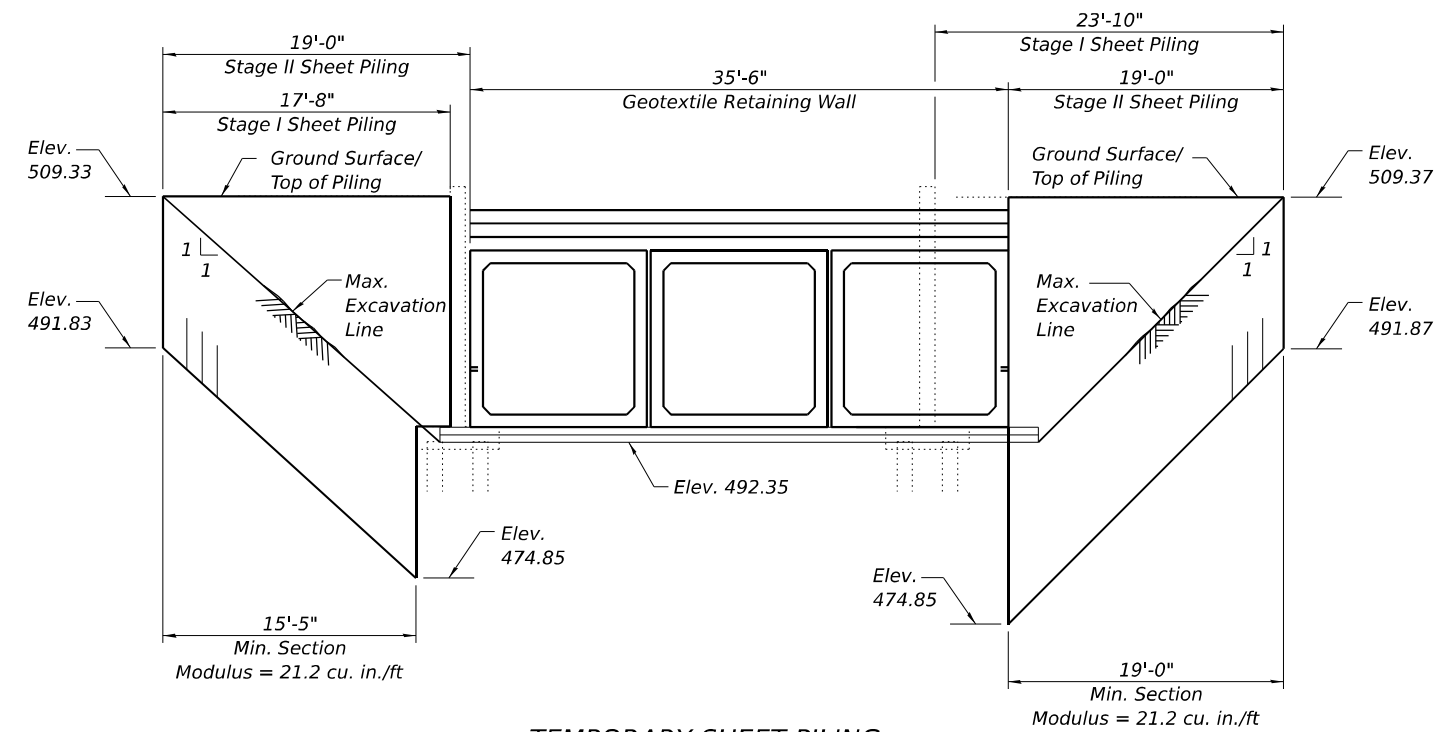

**TEMPORARY SHEET PILING**  
(Looking South)

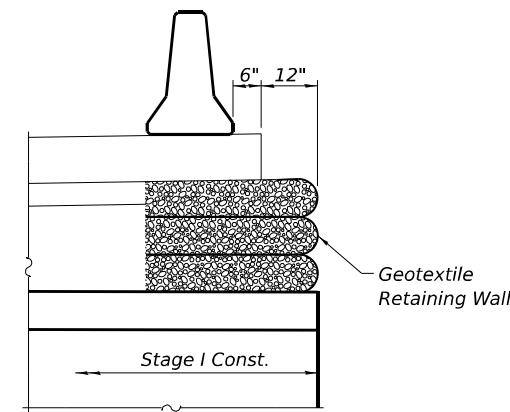

**DETAIL A**

The geotextile soil reinforcement shall have a minimum allowable tensile strength ( $T_{min}$ ) of 17 lb./in. as determined by the procedure described in Section 522 of the Standard Specifications. The computations supporting the determination of  $T_{min}$  shall be submitted to the engineer for approval.

**Notes:**  
 Hatched areas indicate Removal of Existing Structures.  
 All staging sections are looking east.  
 See Roadway Plans for quantity of Temporary Concrete Barrier.  
 If the Contractor chooses to alter the temporary cantilevered sheet piling design requirements shown on the plans, a design submittal including plan details and calculations will be required for review and acceptance by the Engineer.  
 The Contractor shall connect the first sheet to the existing abutment wall to ensure stability of sheets driven to the top of the existing footing. This connection shall be reviewed and accepted by the Engineer and included in the cost for Temporary Sheet Piling.

MODEL: D:\proj\12172024\12172024-01-Struct\Final Design\CADD (ORR)\CADD\_Sheets\011011612701614-CU-StageConstD1.dwg  
 FILE NAME: E:\2023\Struct\Final Design\CADD (ORR)\CADD\_Sheets\011011612701614-CU-StageConstD1.dwg  
 12/17/2024 8:28:41 AM

**LE** LIN ENGINEERING, LTD.  
 Consulting Engineers  
 Springfield, Illinois

USER NAME = Ljh10-PC	DESIGNED - CZ	REVISED -
PLOT SCALE = 0:2,00000 "/> <td>CHECKED - CL</td> <td>REVISED -</td>	CHECKED - CL	REVISED -
PLOT DATE = 12/17/2024	DRAWN - SJH	REVISED -
	CHECKED - CL	REVISED -

**STATE OF ILLINOIS**  
**DEPARTMENT OF TRANSPORTATION**

**STAGE CONSTRUCTION DETAILS**  
**STRUCTURE NO. 001-2503**  
 SHEET 3 OF 7 SHEETS

F.A.P. RTE. 502	SECTION 42BR	COUNTY ADAMS	TOTAL SHEETS 38	SHEET NO. 22
CONTRACT NO. 72G18				
ILLINOIS FED. AID PROJECT				

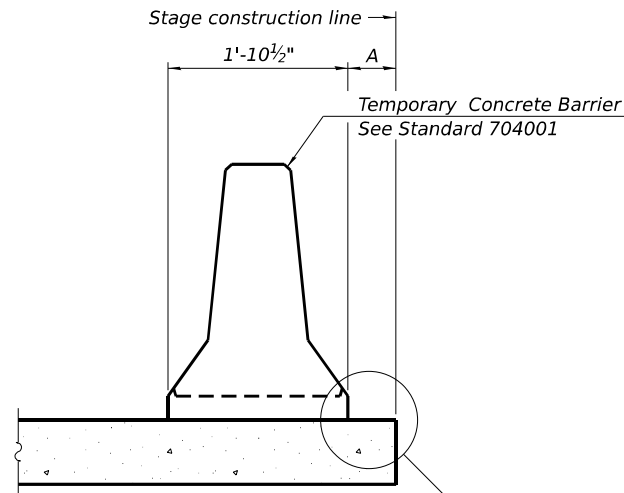

When "A" is 3'-1" or less, the temporary concrete barrier shall be restrained to the new slab according to Detail I, II or III. No restraint is required when "A" is greater than 3'-1".

**NEW SLAB OR NEW DECK BEAM**

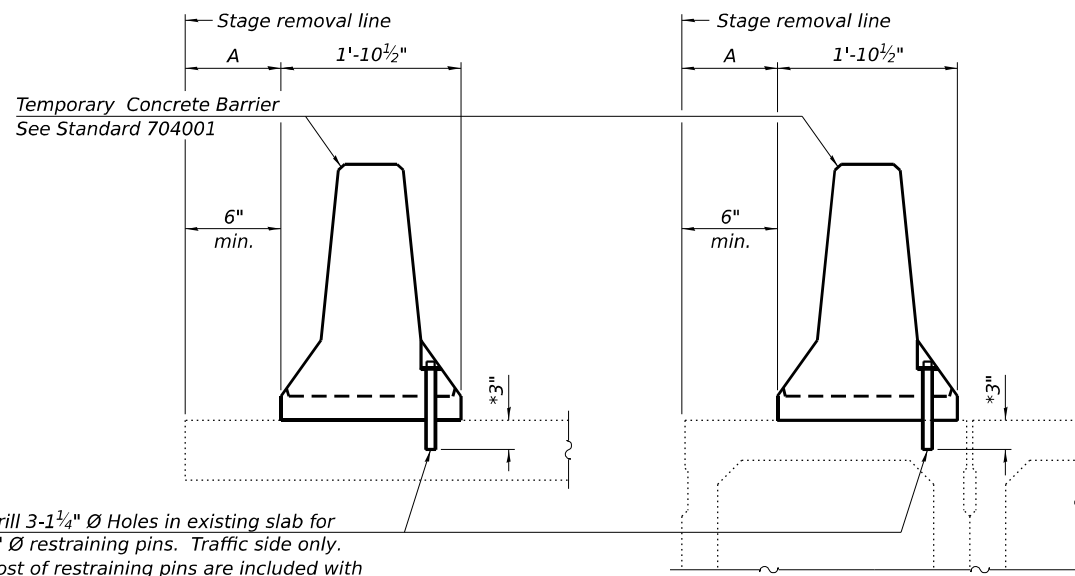

Drill 3-1/4" Ø Holes in existing slab for 1" Ø restraining pins. Traffic side only. Cost of restraining pins are included with Temporary Concrete Barrier. No restraint is required when "A" is greater than 3'-1".

**EXISTING SLAB**

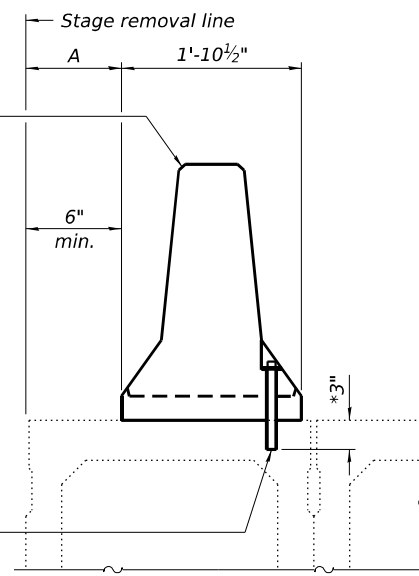

\* When hot-mix asphalt wearing surface is present, embedment shall be 3" plus the wearing surface depth.

**EXISTING DECK BEAM**

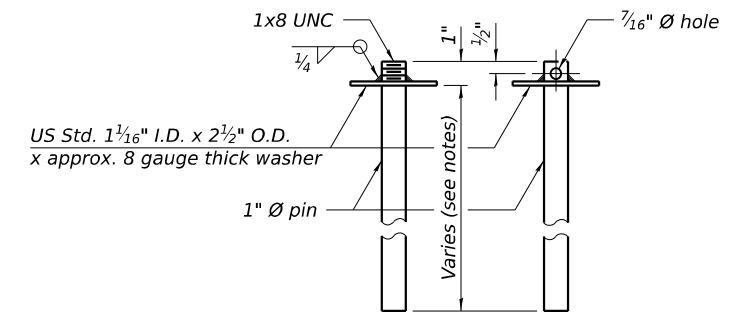

**RESTRAINING PIN**

**SECTIONS THRU SLAB OR DECK BEAM**

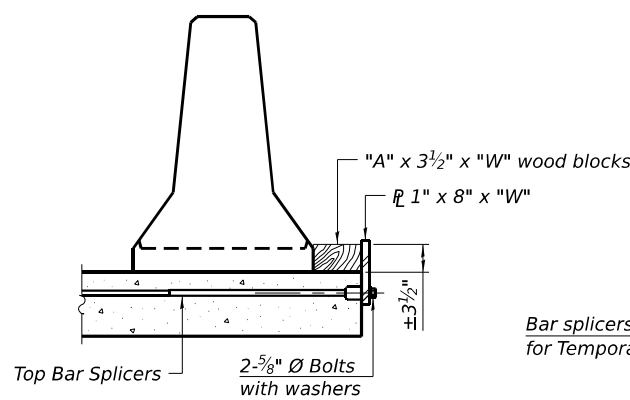

**DETAIL I**

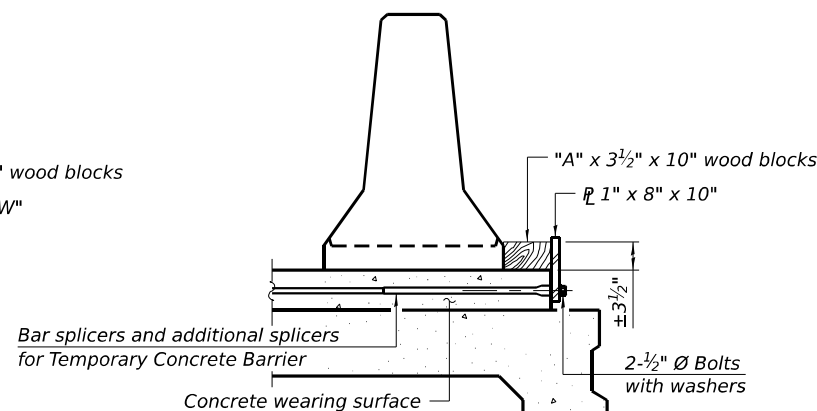

**DETAIL II**

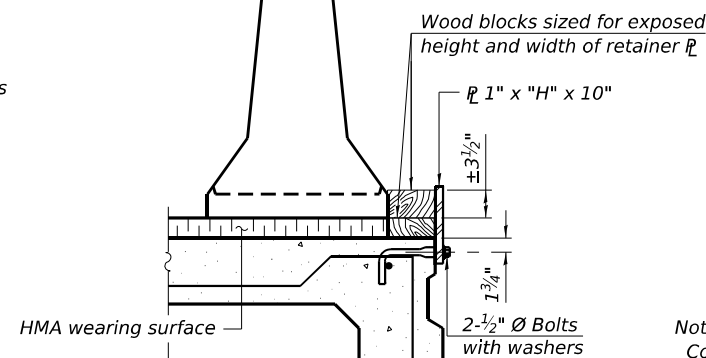

**DETAIL III**

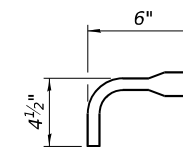

**BAR SPLICER FOR #4 BAR - DETAIL III**

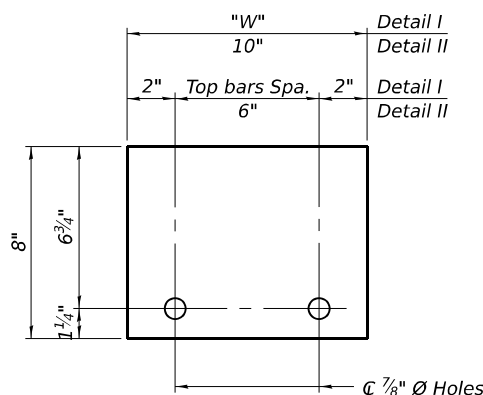

**STEEL RETAINER 1" x 8" x "W"**  
(Detail I and II)

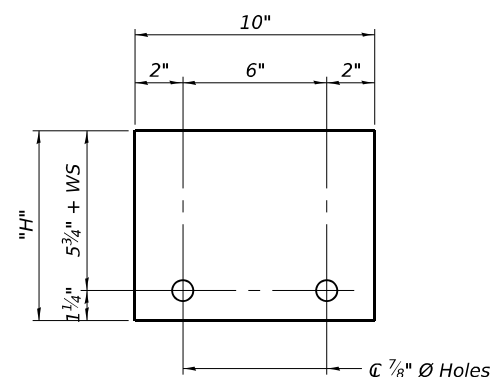

**STEEL RETAINER 1" x "H" x 10"**  
(Detail III)

**Notes:**  
 Cost of retainer assembly is included with Temporary Concrete Barrier.  
 A retainer assembly shall be located at the approximate center of each temporary concrete barrier.  
 The retainer plate shall not be removed until the concrete on the adjacent stage is ready to be poured. For Detail III applications the retainer plate shall not be removed until just prior to placing the adjacent beam.  
 When the 'A' dimension is less than 1 1/2", the wood block shall be omitted and the barrier shall be placed in direct contact with the steel retainer plate.  
 For deck beam applications the minimum required 'A' distance is 6" to accommodate the shear key clamping device.

**Detail I - Installation for a new bridge deck or bridge slab.**

**Detail II - Installation for a new deck beam with an initial concrete wearing surface.** Additional bar splicers shall be provided at 6'-0" centers and paired with the bar splicers of the concrete wearing surface reinforcement to accommodate the installation of the retainer assemblies. The cost of the additional bar splicers is included with the concrete wearing surface.

**Detail III - Installation for a new deck beam with no initial wearing surface or with an initial hot-mix asphalt (HMA) wearing surface present.** The deck beam directly beneath the temporary concrete barrier shall be fabricated with bar splicer inserts in the side of the beam, as detailed, to accommodate the installation of the retainer assemblies. A pair of bar splicers, 6" apart, shall be placed at 6'-0" centers along the length of the beam. The cost of the bar splicers is included with the deck beam.

**RAILING CRITERIA**

NCHRP 350 Test Level	3
Railing Weight (plf)	440

R-27 5-15-2023

MODEL: D:\proj\2023\Structure\Final Design\CADD (OR)\CADD\_Sheets\01\01\15-23\15-23-TempConcreteBarrier.dgn

**LE** LIN ENGINEERING, LTD.  
Consulting Engineers  
Springfield, Illinois

USER NAME = Ljh10-PC	DESIGNED - CZ	REVISED -
PLOT SCALE = 02" / 1'	CHECKED - CL	REVISED -
PLOT DATE = 12/17/2024	DRAWN - SJH	REVISED -
	CHECKED - CL	REVISED -

**STATE OF ILLINOIS  
DEPARTMENT OF TRANSPORTATION**

**TEMPORARY CONCRETE BARRIER  
STRUCTURE NO. 001-2503**

SHEET 4 OF 7 SHEETS

F.A.P. RTE. 502	SECTION 42BR	COUNTY ADAMS	TOTAL SHEETS 38	SHEET NO. 23
CONTRACT NO. 72G18				
ILLINOIS FED. AID PROJECT				

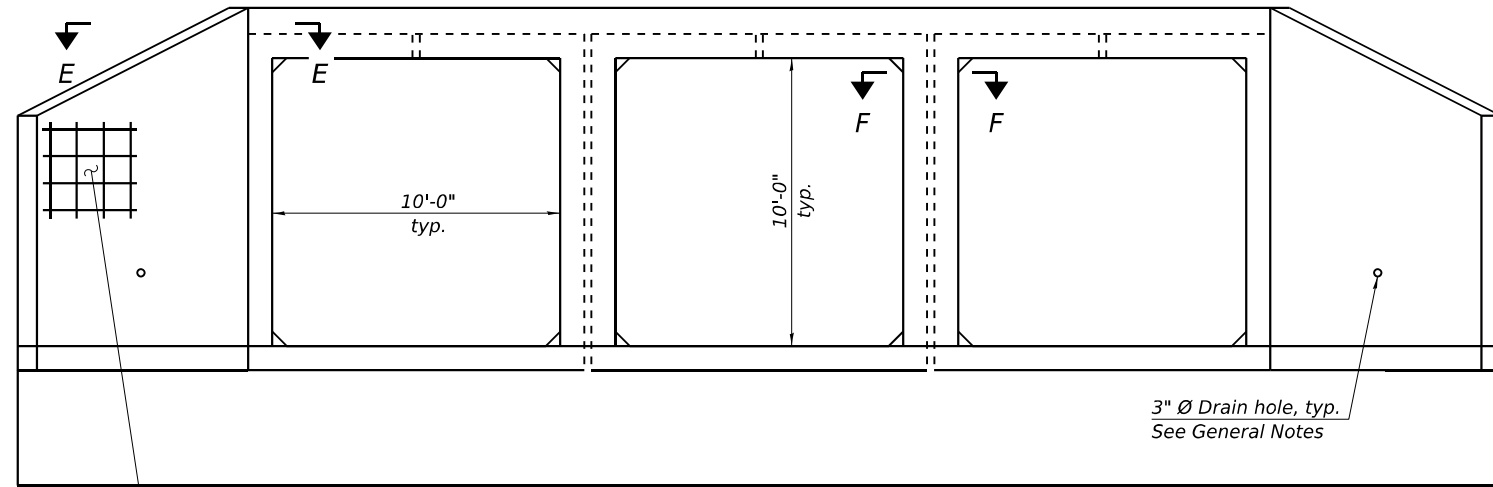

21-#6 v bar Front Face  
or 21-#6 v1 bar at 9" cts.  
Back Face (Cut to fit)  
12-#4 h bar at 12" cts.  
Each Face (Fan top bars)  
(Typ. each wingwall)

**END VIEW**

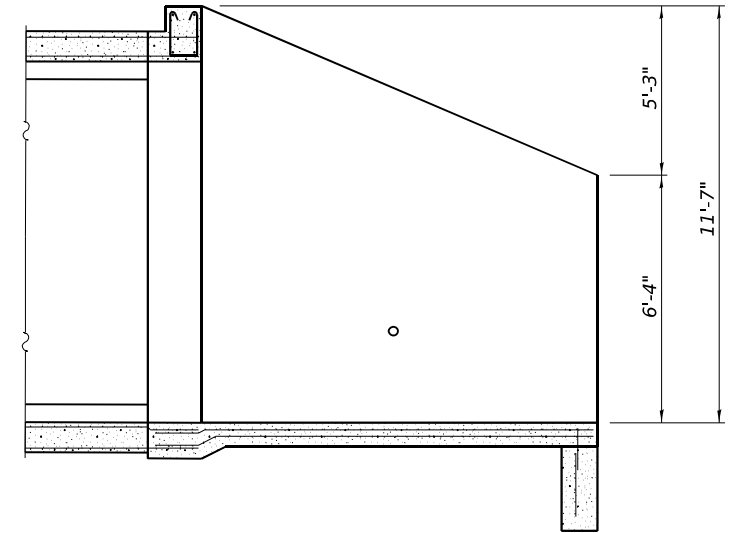

**SECTION A-A**

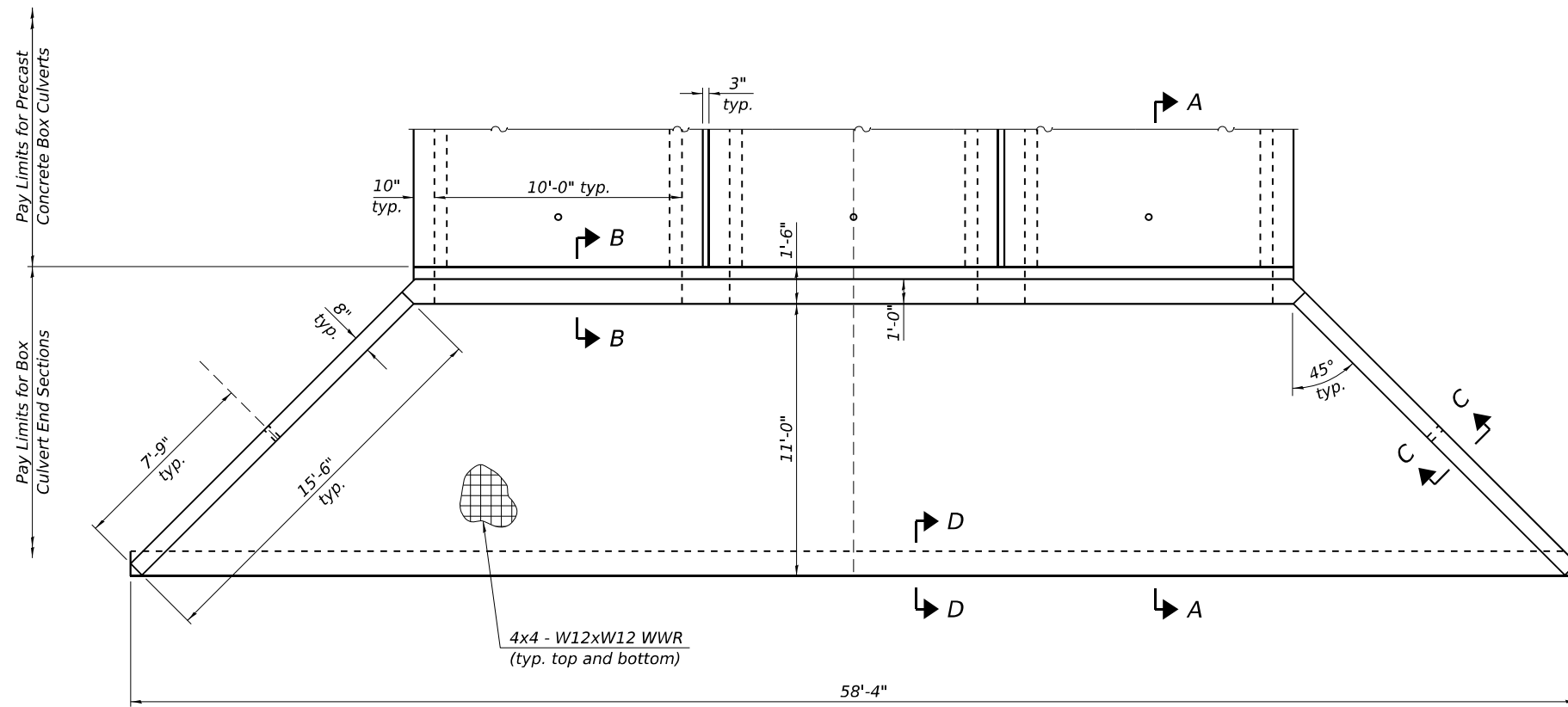

**PLAN**

**GENERAL NOTES**

Box Culvert End Sections shall be constructed according to the requirements of Section 540 of the Standard Specifications except as modified herein. End sections will be paid for at the contract unit price per each for Box Culvert End Sections.

Box section dimensions, materials, and reinforcement details for Box Culvert End Sections shall be according to the requirements for ASTM C 1577 as required for the design of the portion of the culvert within the limits of Precast Concrete Box Culverts except as modified herein.

The details contained herein are for constructing the end sections using cast-in-place (CIP) construction.

The contractor may use reinforcement bars in lieu of welded wire reinforcement (WWR). Reinforcement bars shall be limited to the sizes of #3 through #5 bars, a maximum spacing of the lesser of 8" or the member thickness, and shall result in an area of reinforcement equal to or greater than that provided by the WWR. Minimum lap lengths detailed herein are applicable to WWR and reinforcement bars.

Reinforcement (circumferential and longitudinal) in the precast concrete box culvert segments immediately adjacent to the box culvert end sections that is being lapped with the end section reinforcement shall not be less than that required by ASTM C 1577 for the design fill height or the reinforcement detailed for the end section, whichever is greater.

One drain hole shall be provided in each wingwall for end sections of box culverts having an opening with a clear rise greater than 3 ft. The drain hole shall be located within 1/3 of the clear rise of the box culvert and shall conform to the requirements of Article 503.11 of the Standard Specifications.

(Sheet 1 of 2)

MODEL: D:\proj\12172024\Structure\Final Design\CADD (ORD)\CADD\_Sheets\01\01\16\27\016-Culvert\End\Detail.dwg  
FILE NAME: E:\2023\Structure\Final Design\CADD (ORD)\CADD\_Sheets\01\01\16\27\016-Culvert\End\Detail.dwg



USER NAME = Ljh10-PC  
PLOT SCALE = 0:2,00000 1" / ft.  
PLOT DATE = 12/17/2024

DESIGNED - CZ  
CHECKED - CL  
DRAWN - SJH  
CHECKED - CL

REVISED -  
REVISED -  
REVISED -  
REVISED -

**STATE OF ILLINOIS  
DEPARTMENT OF TRANSPORTATION**

**BOX CULVERT END SECTION DETAILS  
STRUCTURE NO. 001-2503**

SHEET 5 OF 7 SHEETS

F.A.P. RTE.	SECTION	COUNTY	TOTAL SHEETS	SHEET NO.
502	42BR	ADAMS	38	24
CONTRACT NO. 72G18				

ILLINOIS FED. AID PROJECT



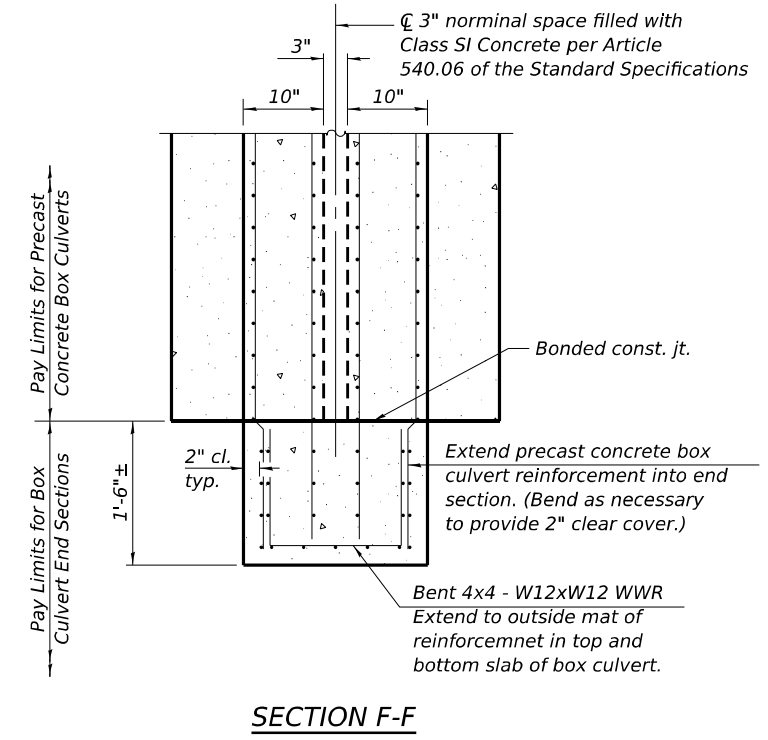
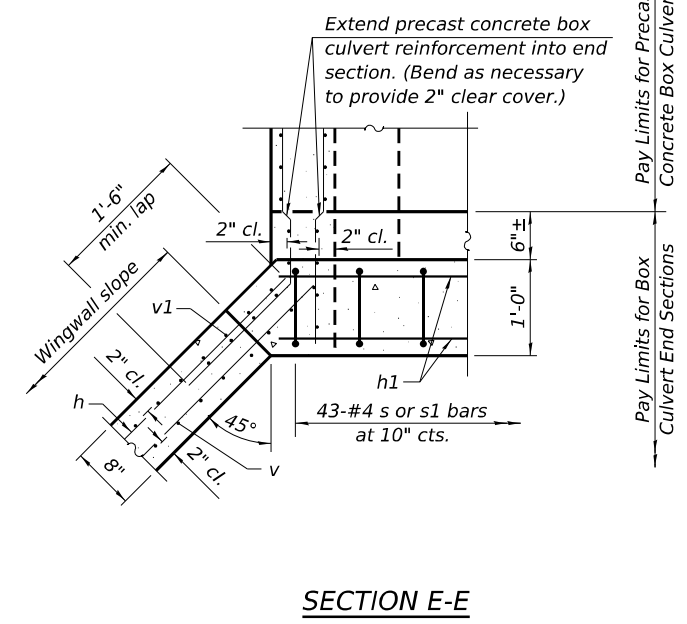
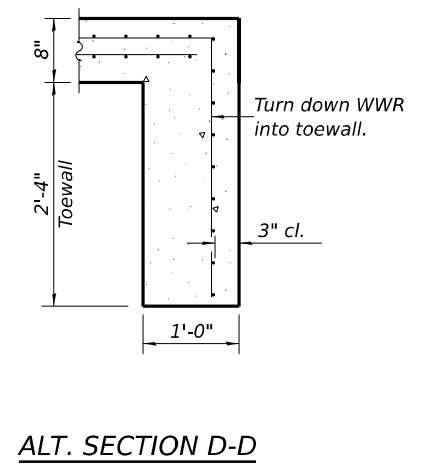
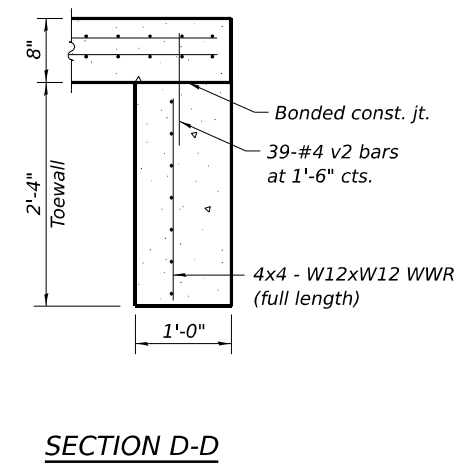
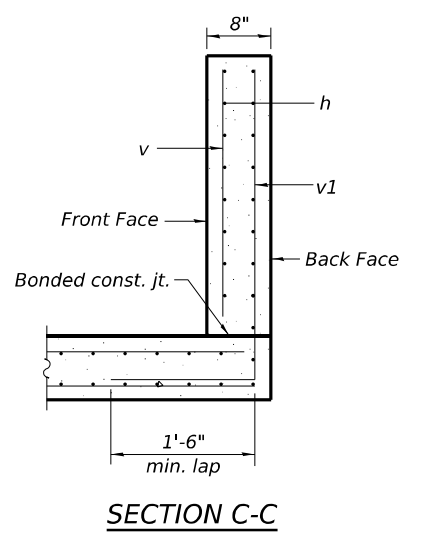
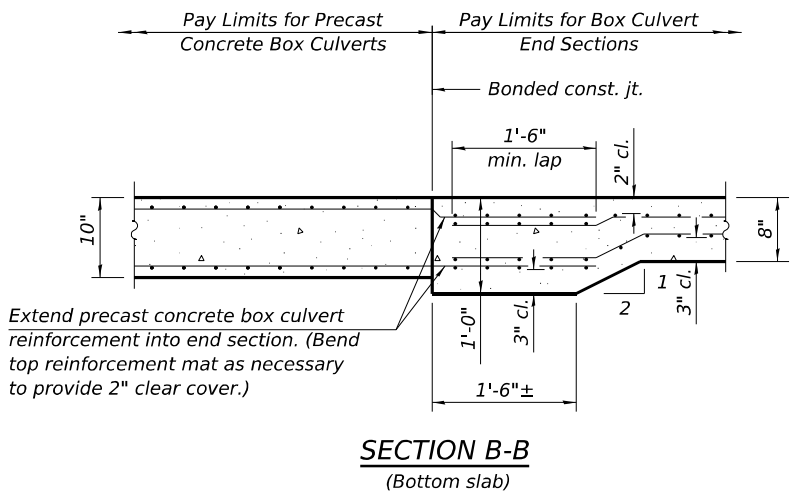
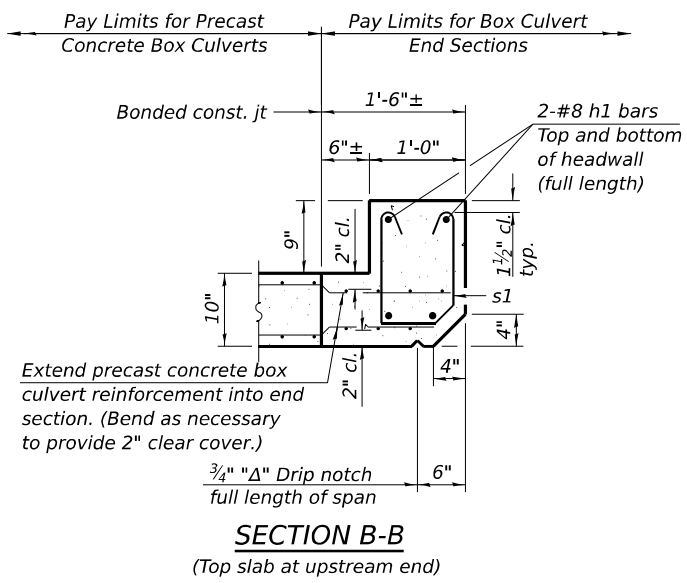
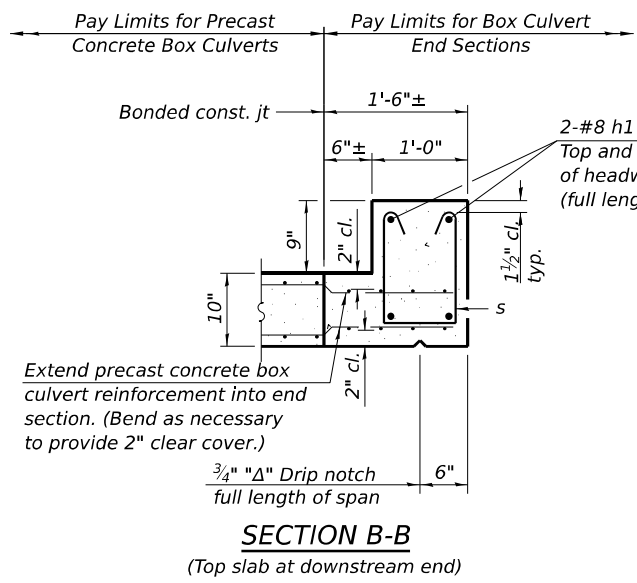

**TOEWALL CONSTRUCTION SEQUENCE**

1. Perform excavation and construct toewall.
2. Backfill accordingly and prepare bedding for box culvert end sections.
3. Construct remainder of box culvert end section.

Note:  
If soil conditions permit, the toewall may be poured monolithically with the bottom slab of the end section using Alt. Section D-D subject to approval from the Engineer.

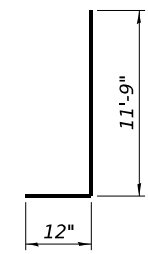
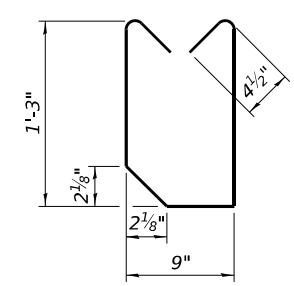
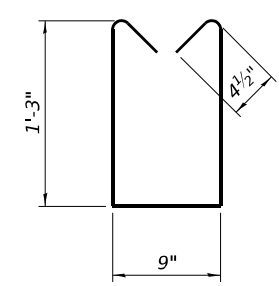

**BILL OF MATERIAL**

(For Information only. Material included with pay item Box Culvert End Sections, Culvert No. 1) (Material for both End Sections)

Bar	No.	Size	Length	Shape
h	96	#4	15'-10"	—
h1	8	#8	35'-3"	—
s	86	#4	4'-0"	—
s1	86	#4	3'-11"	—
v	84	#6	11'-3"	—
v1	84	#6	12'-9"	—
v2	78	#4	2'-0"	—
Reinforcement Bars		Lbs.	5,360	
Concrete Box Culverts		Cu. Yd.	59.4	

(Sheet 2 of 2)

MODEL: D:\proj\12172024\STRUCT\Final Design\CADD (OR) \CADD\_Sheets\01\01\02\2015-04-09-Cu-Culvert\12172024.dwg  
 FILE NAME: E:\2015-04-09\Struct\Final Design\CADD (OR) \CADD\_Sheets\01\01\02\2015-04-09-Cu-Culvert\12172024.dwg



USER NAME = Ljh10-PC	DESIGNED - CZ	REVISED -
PLOT SCALE = 02'"/ft.	CHECKED - CL	REVISED -
PLOT DATE = 12/17/2024	DRAWN - SJH	REVISED -
	CHECKED - CL	REVISED -

STATE OF ILLINOIS  
DEPARTMENT OF TRANSPORTATION

BOX CULVERT END SECTION DETAILS  
STRUCTURE NO. 001-2503

SHEET 6 OF 7 SHEETS

F.A.P. RTE. 502	SECTION 42BR	COUNTY ADAMS	TOTAL SHEETS 38	SHEET NO. 25
CONTRACT NO. 72G18				
ILLINOIS FED. AID PROJECT				



# SOIL BORING LOG

Page 1 of 1

Date 2/28/24

ROUTE IL-57 DESCRIPTION IL 57 Bridge SN 001-0016 LOGGED BY P.G.

SECTION LOCATION SEC. TWP. RNG. PM

COUNTY Adams DRILLING METHOD AASHTO T 206-19 HSA HAMMER TYPE Auto Hammer 140 lbs.

STRUCT. NO. Station	D E P T H H S	B L O W S	U C S Qu	M O I S T T	Description	D E P T H H S	B L O W S	U C S Qu	M O I S T T
5" BITUMINOUS CONCRETE PAVEMENT	508.73				SILTY CLAY LOAM, Brown, Trace Sand, Very Stiff, Moist	3			
8" SAND AND GRAVEL BASE COURSE, Dark Brown	508.07	3			(A-6)	4	2.1	20.23	
SILTY LOAM, Dark Gray, Trace Sand, Medium to Stiff, Moist		3	0.55	22.77					
		3	B						
		5							
		3	1.04	19.03					
		2	B/S						
		-8							
SAND AND GRAVEL, Brown, Medium Dense, Dry	503.15	7							
(A-1-b)		12	5.94						
		10							
SANDY LOAM, Brown, Loose, Moist	500.65	2							
(A-2-4)		3	14.00						
		-10							
SAND AND GRAVEL, Brown, Medium Dense, Dry	498.15	7							
(A-1-b)		14	5.61						
		12							
SANDY LOAM, Brown, Loose, Dry	495.65	3							
(A-2-4)		4	9.99						
		-15							
SAND, Brown, Trace Gray, Loose, Dry	493.15	4	13.51						
(A-6)		7	B/S						
SILTY LOAM, Brown, Trace Sand, Stiff to Medium, Moist	493.15	3							
(A-4)		3	20.37						
		4	B						
SAND AND GRAVEL, Brown, Medium Dense, Dry	470.65	10							
(A-1-b)		12	2.58						
		3	0.84	22.20					
		4	B						
		-20							
End of Boring at 40 feet.	469.15	-40							
	488.15								

The Unconfined Compressive Strength (UCS) Failure Mode is indicated by (B-Bulge, S-Shear, P-Penetrometer, E-Estimated) Abbreviations W.O.H - Sampler Advanced By Weight of Hammer, W.O.P - Advanced By Weight of Pipe, B.S. - Before Seating The SPT (N value) is the sum of the last two blow values in each sampling zone (AASHTO T206) BBS, from 137 (Rev. 8-99) D-50 Drill Rig Used. SEECO Job No. 12444G-9

File Name I:\REPORTS\GEO\TECH\24444G-9 ADAMS AND BROWN COUNTIES\IL12444G-9\DOT BORINGS ADAMS AND BROWN COUNTIES\IL12444G-9\DOT BORINGS ADAMS AND BROWN COUNTIES\IL12444G-9\DOT Date Printed 4/18/24  
Latitude 39.816908 Longitude -91.3407 Datum Job Number 12444G-9

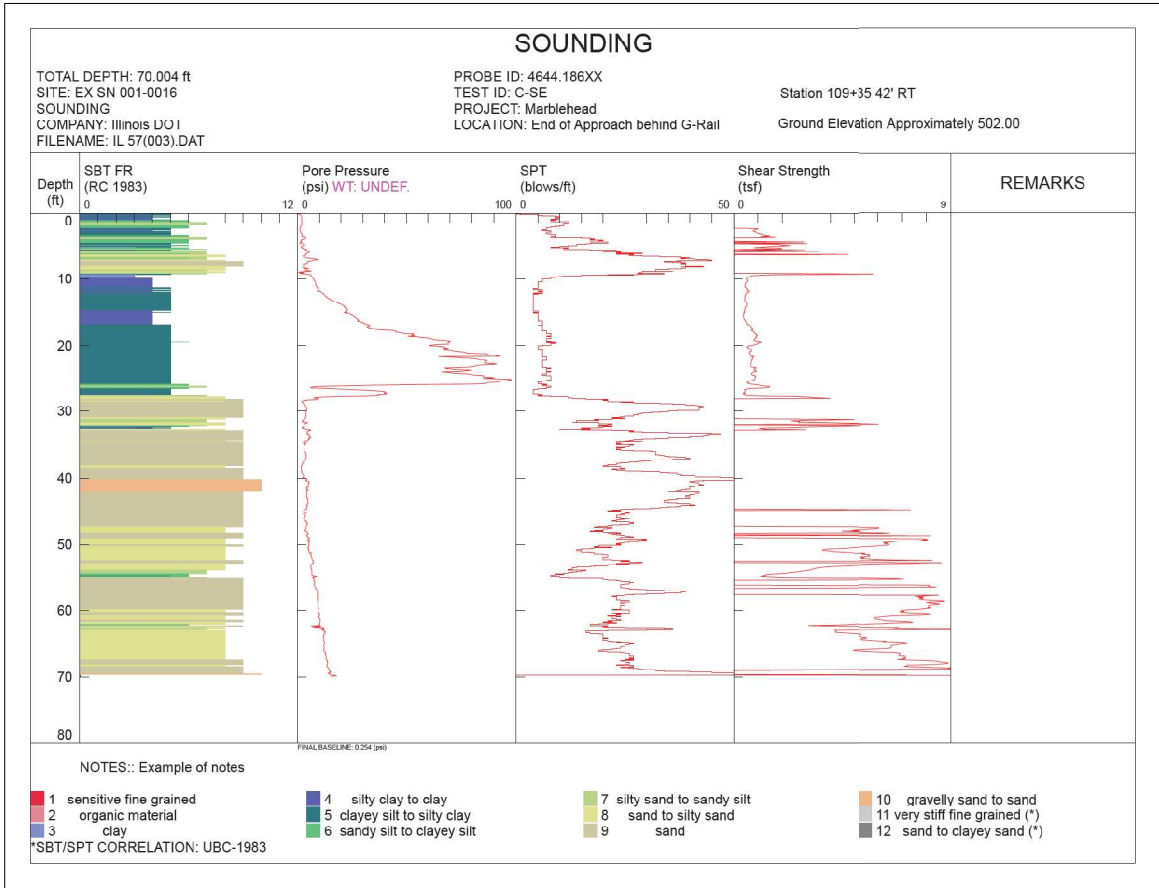
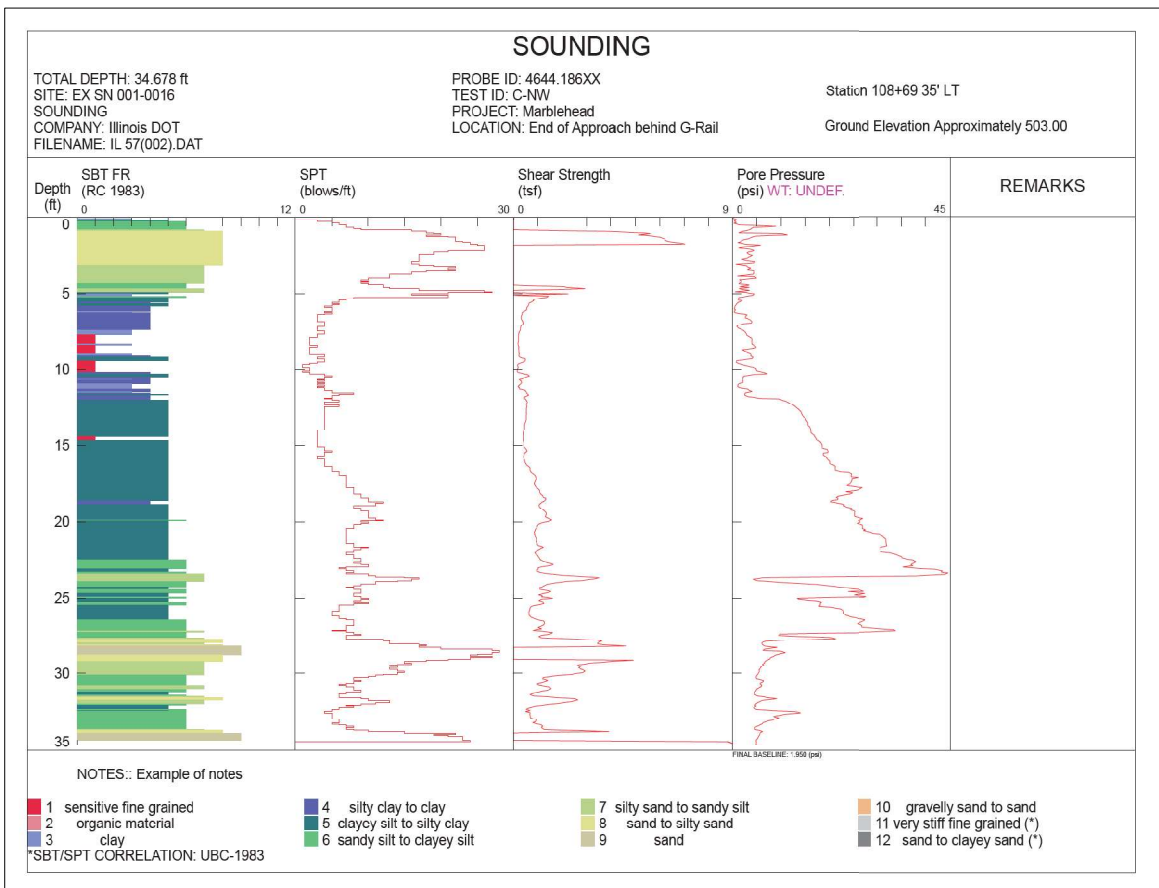

MODEL: D:\shin  
FILE NAME: E:\2023\Structure\Final Design\CADD (ORD)\CADD\_Sheets\01\01\01\12-7-23\12-4-23\SoilBoring.dgn  
12/17/2024 8:28:44 AM



USER NAME = Ljh10-PC	DESIGNED - CZ	REVISED -
PLOT SCALE = 02" = 1' / in.	CHECKED - CL	REVISED -
PLOT DATE = 12/17/2024	DRAWN - SJH	REVISED -
	CHECKED - CL	REVISED -

**STATE OF ILLINOIS  
DEPARTMENT OF TRANSPORTATION**

**SOIL BORING LOG  
STRUCTURE NO. 001-2503**

SHEET 7 OF 7 SHEETS

F.A.P. RTE.	SECTION	COUNTY	TOTAL SHEETS	SHEET NO.
502	42BR	ADAMS	38	26
CONTRACT NO. 72G18				
ILLINOIS FED. AID PROJECT				

FINAL SURVEY NO.	SURVEYED	BY	DATE
NOTE BOOK	PLOTTED		
AREAS CHECKED	TEMPLATE		
	AREAS CHECKED		

ORIGINAL SURVEY NO.	SURVEYED	BY	DATE
NOTE BOOK	PLOTTED		
AREAS CHECKED	TEMPLATE		
	AREAS CHECKED		

MODEL: E:\106+50.00 (Sheet)  
 FILE NAME: E:\2024\CADD\_Sheets\Sheet\8-24-24.dgn

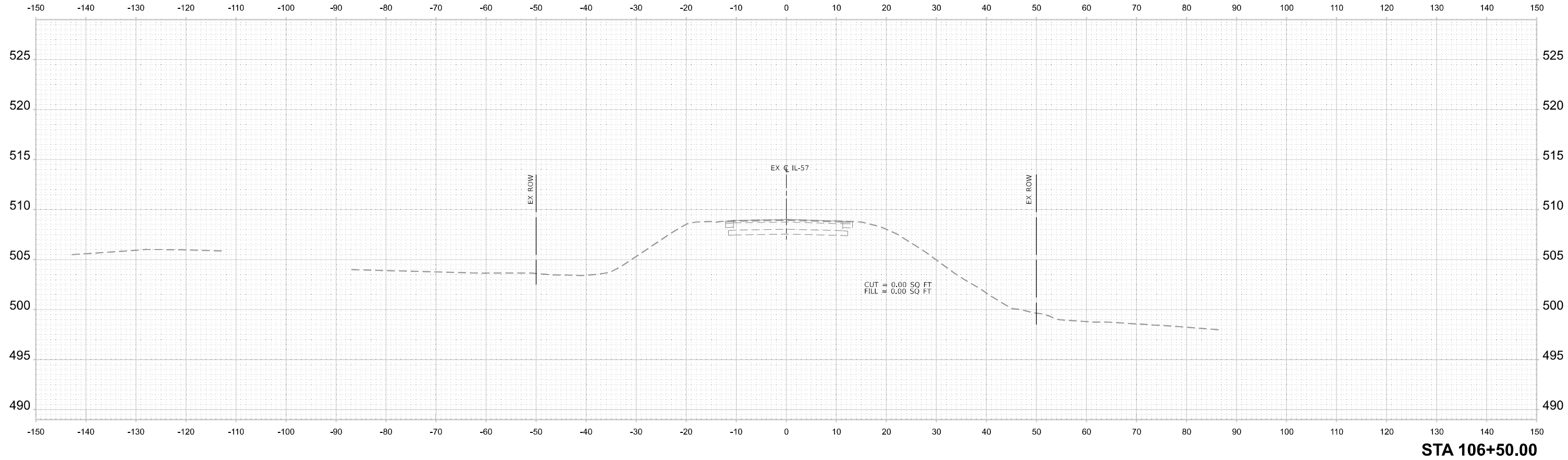

**STA 106+50.00**



USER NAME = 14nho	DESIGNED - NH	REVISED -
	DRAWN - NH	REVISED -
PLOT SCALE = 0.16666667 / in.	CHECKED - RC	REVISED -
PLOT DATE = 10/17/2024	DATE - 11/2024	REVISED -

**STATE OF ILLINOIS  
 DEPARTMENT OF TRANSPORTATION**

**IL RTE 57 OVER HARKNESS CREEK  
 CROSS SECTIONS**

SCALE: 1"=10' SHEET 1 OF 10 SHEETS STA. 106+50.00 TO STA. 106+50.00

F.A.P. RTE.	SECTION	COUNTY	TOTAL SHEETS	SHEET NO.
502	42BR	ADAMS	38	27
ILLINOIS FED. AID PROJECT			CONTRACT NO. 72G18	

DATE	
BY	
SURVEYED	
PLOTTED	
TEMPLATE	
NOTE BOOK	
AREAS CHECKED	
NO.	

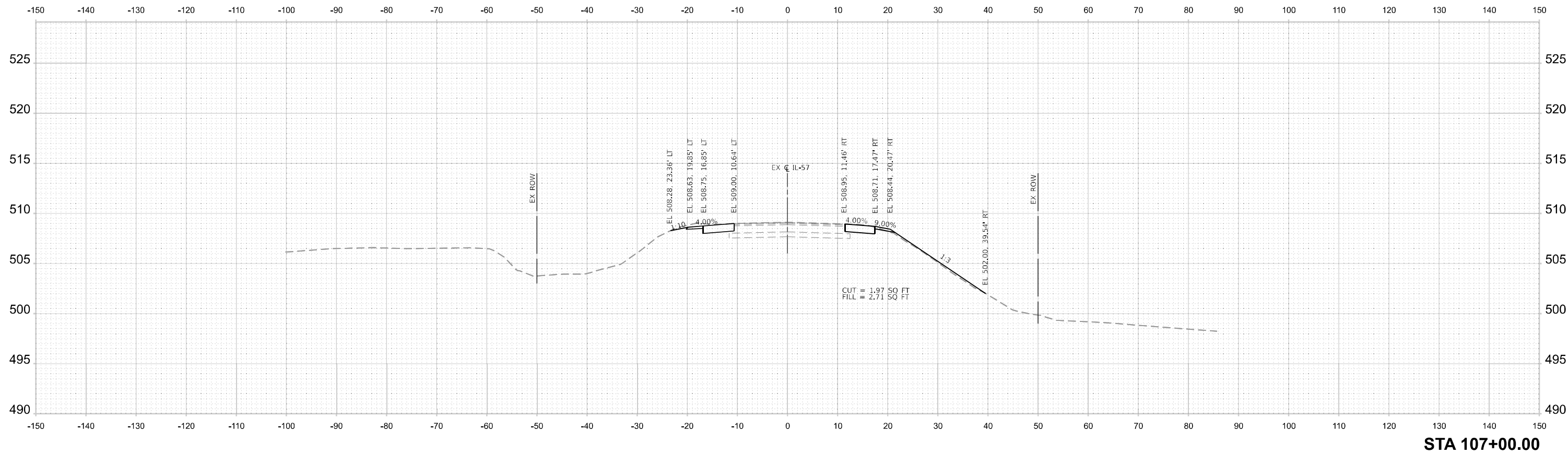

STA 107+00.00

DATE	
BY	
SURVEYED	
PLOTTED	
TEMPLATE	
NOTE BOOK	
AREAS CHECKED	
NO.	

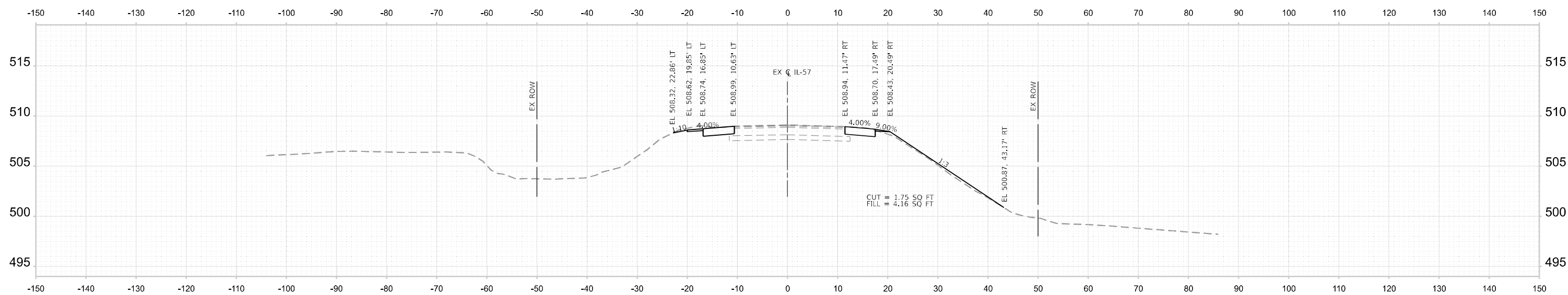

STA 106+95.44

MODEL: EX (9-106+95.44 [Sheet])  
FILE NAME: E:\2023\14\CADD\_Sheets\0672G18.sxd.dgn



USER NAME = 14nho	DESIGNED - NH	REVISED -
	DRAWN - NH	REVISED -
PLOT SCALE = 0.1666667' / in.	CHECKED - RC	REVISED -
PLOT DATE = 10/17/2024	DATE - 11/2024	REVISED -

STATE OF ILLINOIS  
DEPARTMENT OF TRANSPORTATION

IL RTE 57 OVER HARKNESS CREEK CROSS SECTIONS			
SCALE: 1"=10'	SHEET 2 OF 10 SHEETS	STA. 106+95.44 TO STA. 107+00.00	

F.A.P. RTE.	SECTION	COUNTY	TOTAL SHEETS	SHEET NO.
502	42BR	ADAMS	38	28
				CONTRACT NO. 72G18
				ILLINOIS FED. AID PROJECT

DATE	
BY	
SURVEYED	
PLOTTED	
TEMPLATE	
AREAS	
CHECKED	
AREAS CHECKED	
NO.	

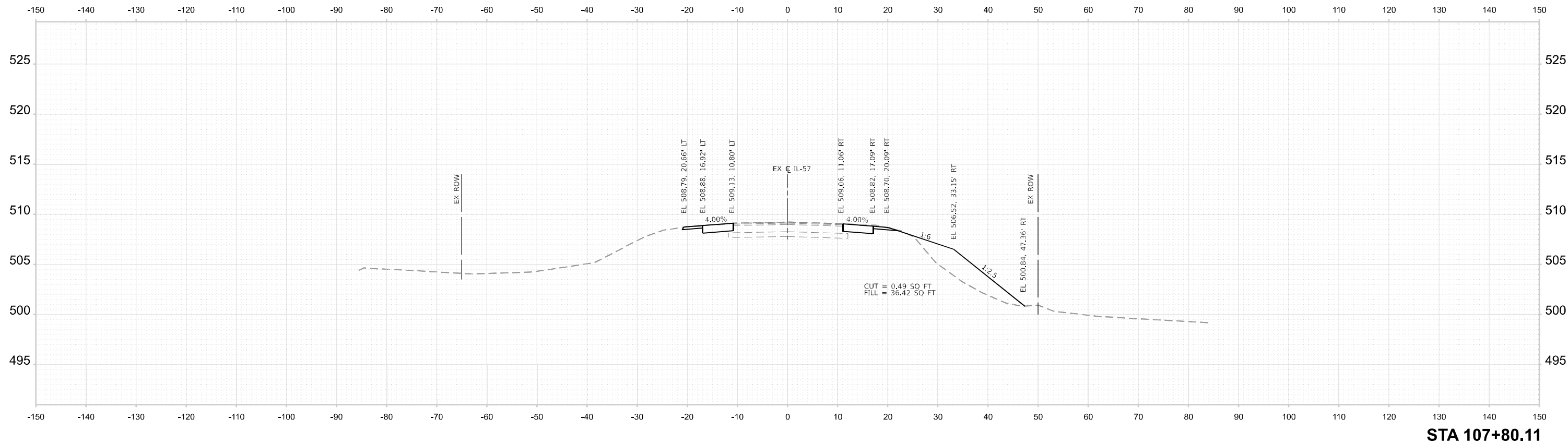

**STA 107+80.11**

DATE	
BY	
SURVEYED	
PLOTTED	
TEMPLATE	
AREAS	
CHECKED	
AREAS CHECKED	
NO.	

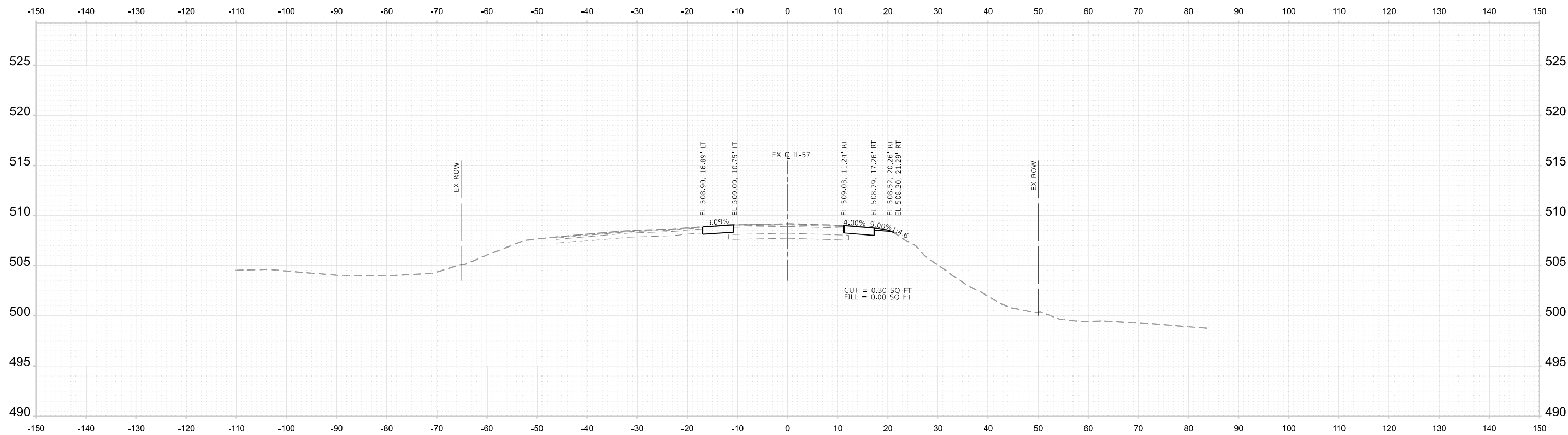

**STA 107+50.00**

MODEL: EX (9-107+50.00 [Sheet])  
FILE NAME: E:\203-1\CADD\_Sheets\072G1 8-83.dgn



USER NAME = 14nho	DESIGNED - NH	REVISED -
	DRAWN - NH	REVISED -
PLOT SCALE = 0.16666667' / in.	CHECKED - RC	REVISED -
PLOT DATE = 10/17/2024	DATE - 11/2024	REVISED -

**STATE OF ILLINOIS  
DEPARTMENT OF TRANSPORTATION**

**IL RTE 57 OVER HARKNESS CREEK  
CROSS SECTIONS**

SCALE: 1"=10'    SHEET 3 OF 10 SHEETS    STA. 107+50.00 TO STA. 107+80.11

F.A.P. RTE.	SECTION	COUNTY	TOTAL SHEETS	SHEET NO.
502	42BR	ADAMS	38	29
CONTRACT NO. 72G18				
ILLINOIS FED. AID PROJECT				

DATE	
BY	
FINAL SURVEY	SURVEYED
NOTE BOOK	PLOTTED
NO.	TEMPLATE
	AREAS CHECKED

DATE	
BY	
ORIGINAL SURVEY	SURVEYED
NOTE BOOK	PLOTTED
NO.	TEMPLATE
	AREAS CHECKED

MODEL: E:\9-108+00.00 [Sheet]  
FILE NAME: E:\2031\CADD\_Sheets\Dr72G18.sxd.dgn

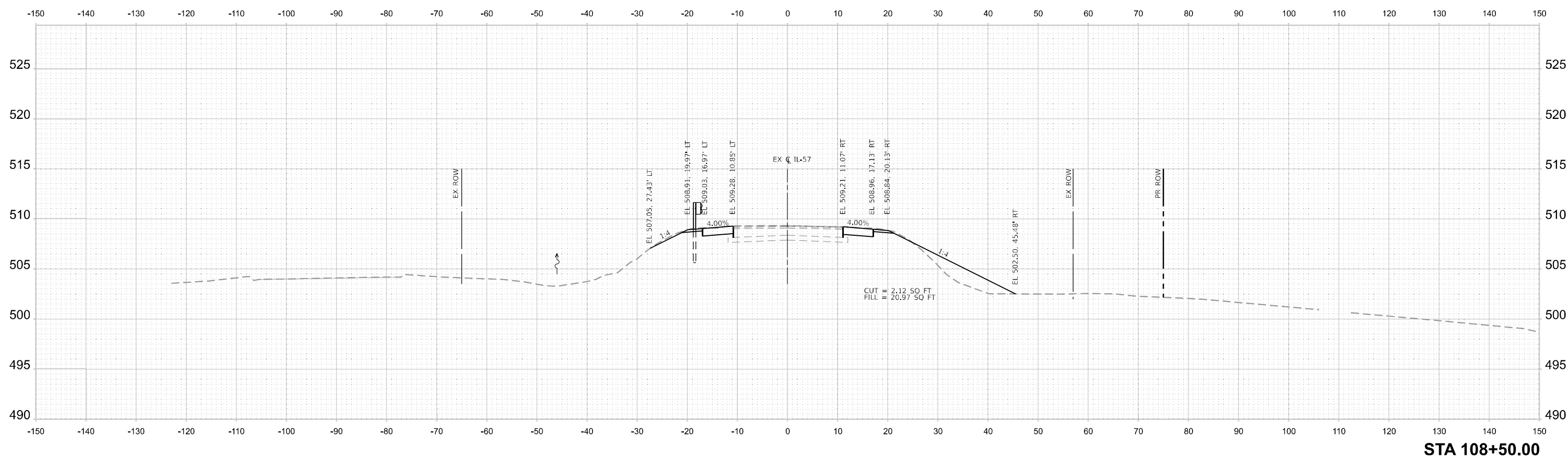

STA 108+50.00

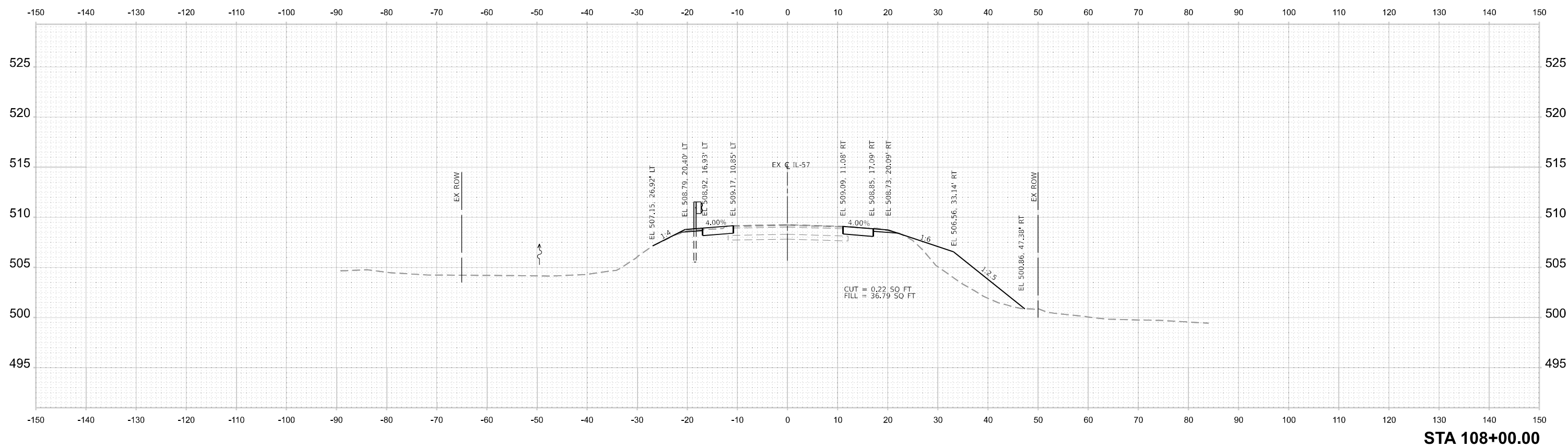

STA 108+00.00



USER NAME = 14nho	DESIGNED - NH	REVISED -
	DRAWN - NH	REVISED -
PLOT SCALE = 0.16666667' / in.	CHECKED - RC	REVISED -
PLOT DATE = 10/18/2024	DATE - 11/2024	REVISED -

STATE OF ILLINOIS  
DEPARTMENT OF TRANSPORTATION

IL RTE 57 OVER HARKNESS CREEK CROSS SECTIONS			
SCALE: 1"=10'	SHEET 4	OF 10 SHEETS	STA. 108+00.00 TO STA. 108+50.00

F.A.P. RTE.	SECTION	COUNTY	TOTAL SHEETS	SHEET NO.
502	42BR	ADAMS	38	30
CONTRACT NO. 72G18				
ILLINOIS FED. AID PROJECT				

FINAL SURVEY	SURVEYED	DATE
NOTE BOOK	PLOTTED	BY
NO.	TEMPLATE	
	AREAS CHECKED	
	AREAS CHECKED	

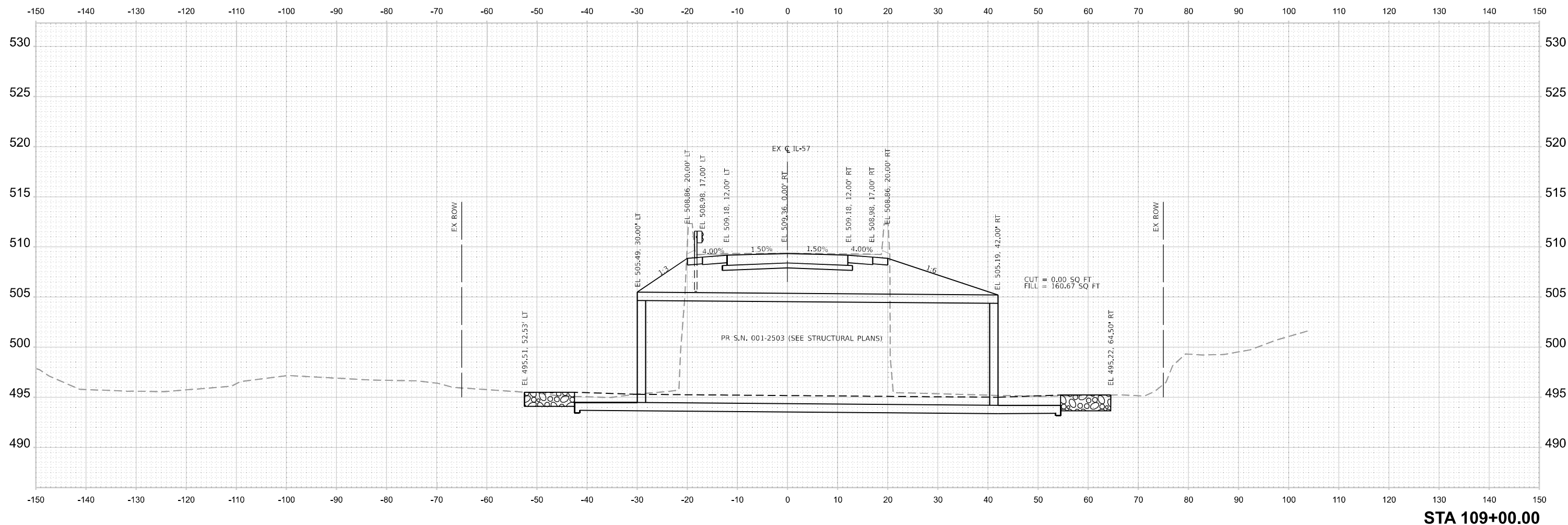

STA 109+00.00

ORIGINAL SURVEY	SURVEYED	DATE
NOTE BOOK	PLOTTED	BY
NO.	TEMPLATE	
	AREAS CHECKED	
	AREAS CHECKED	

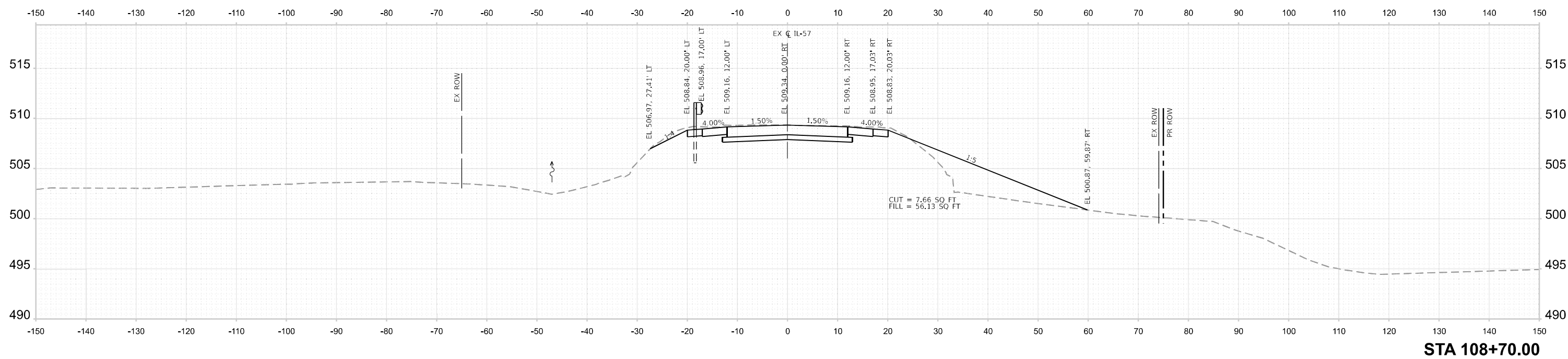

STA 108+70.00

MODEL: EX (9-108+70.00 Sheet)  
FILE NAME: E:\2031\CADD\_Sheets\0872318.sxd.dgn



USER NAME = 14nho	DESIGNED - NH	REVISED -
	DRAWN - NH	REVISED -
PLOT SCALE = 0.1666667' / in.	CHECKED - RC	REVISED -
PLOT DATE = 10/18/2024	DATE - 11/2024	REVISED -

STATE OF ILLINOIS  
DEPARTMENT OF TRANSPORTATION

IL RTE 57 OVER HARKNESS CREEK CROSS SECTIONS			
SCALE: 1"=10'	SHEET 5	OF 10 SHEETS	STA. 180+70.00 TO STA. 109+00.00

F.A.P. RTE.	SECTION	COUNTY	TOTAL SHEETS	SHEET NO.
502	42BR	ADAMS	38	31
				CONTRACT NO. 72G18
				ILLINOIS FED. AID PROJECT

DATE	
BY	
SURVEYED	
PLOTTED	
TEMPLATE	
AREAS	
CHECKED	
NO.	

DATE	
BY	
SURVEYED	
PLOTTED	
TEMPLATE	
AREAS	
CHECKED	
NO.	

MODEL: E:\20-109+30.00 (Sheet)  
FILE NAME: E:\2031\CADD\_Sheets\Dr72G18.dwg

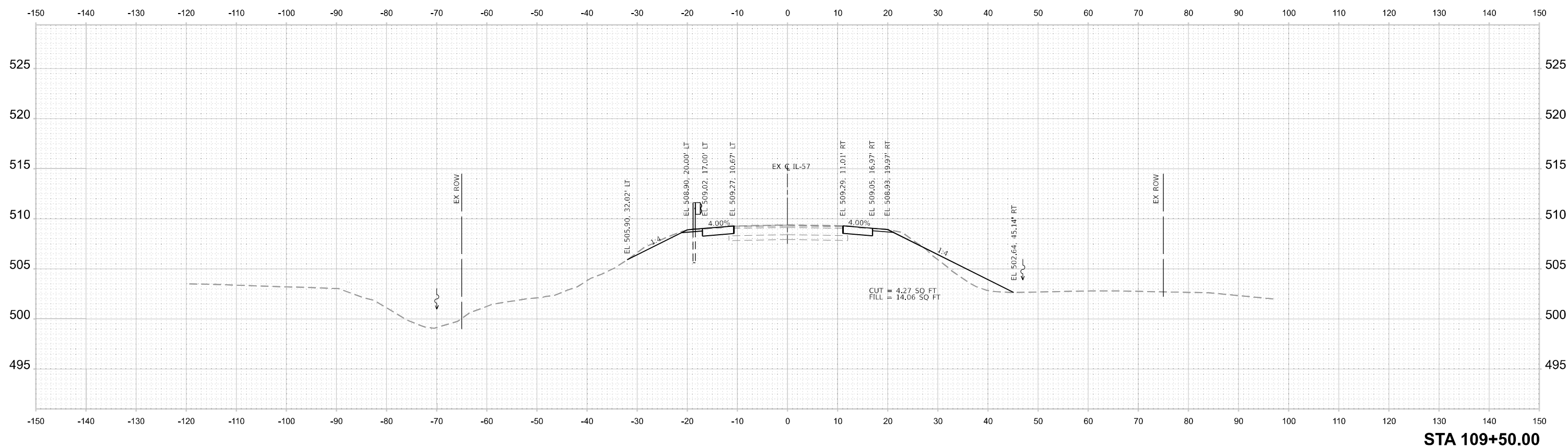

STA 109+50.00

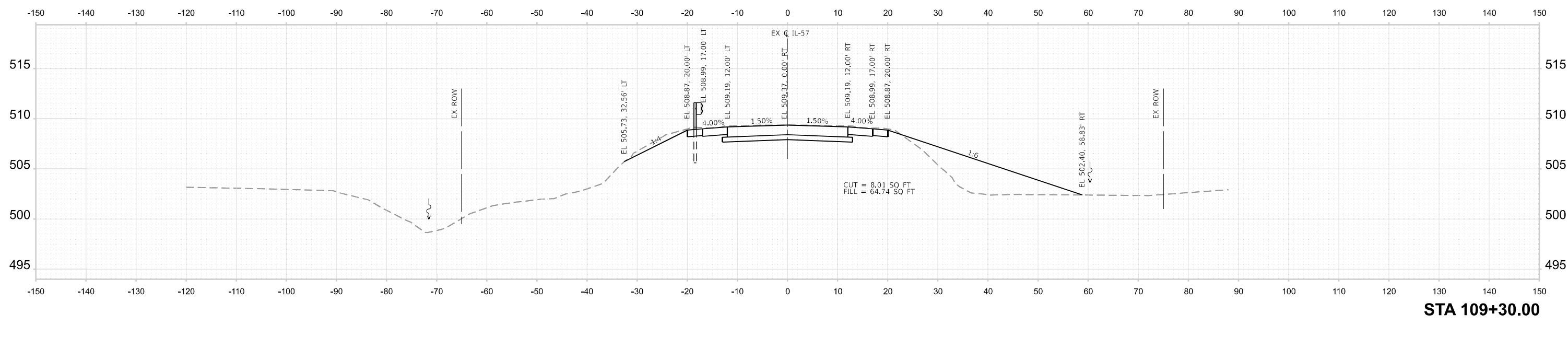

STA 109+30.00



USER NAME = 14nho	DESIGNED - NH	REVISED -
	DRAWN - NH	REVISED -
PLOT SCALE = 0.1666667' / in.	CHECKED - RC	REVISED -
PLOT DATE = 10/17/2024	DATE - 11/2024	REVISED -

STATE OF ILLINOIS  
DEPARTMENT OF TRANSPORTATION

IL RTE 57 OVER HARKNESS CREEK  
CROSS SECTIONS

SCALE: 1"=10' SHEET 6 OF 10 SHEETS STA. 109+30.00 TO STA. 109+50.00

F.A.P. RTE.	SECTION	COUNTY	TOTAL SHEETS	SHEET NO.
502	42BR	ADAMS	38	32
				CONTRACT NO. 72G18
				ILLINOIS FED. AID PROJECT



DATE	
BY	
SURVEYED	
PLOTTED	
TEMPLATE	
NOTE BOOK	
AREAS CHECKED	
NO.	

DATE	
BY	
SURVEYED	
PLOTTED	
TEMPLATE	
NOTE BOOK	
AREAS CHECKED	
NO.	

MODEL: EX (9'-109+75.49 [Sheet])  
FILE NAME: E:\2023\CADD\_Sheets\8723\8-8-23.dgn

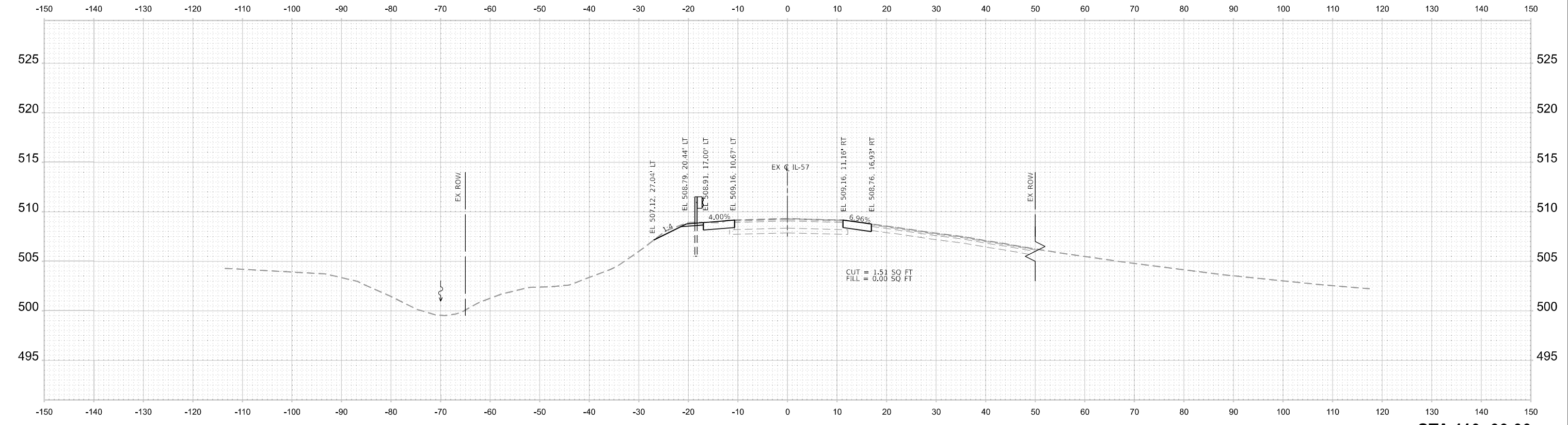

STA 110+00.00

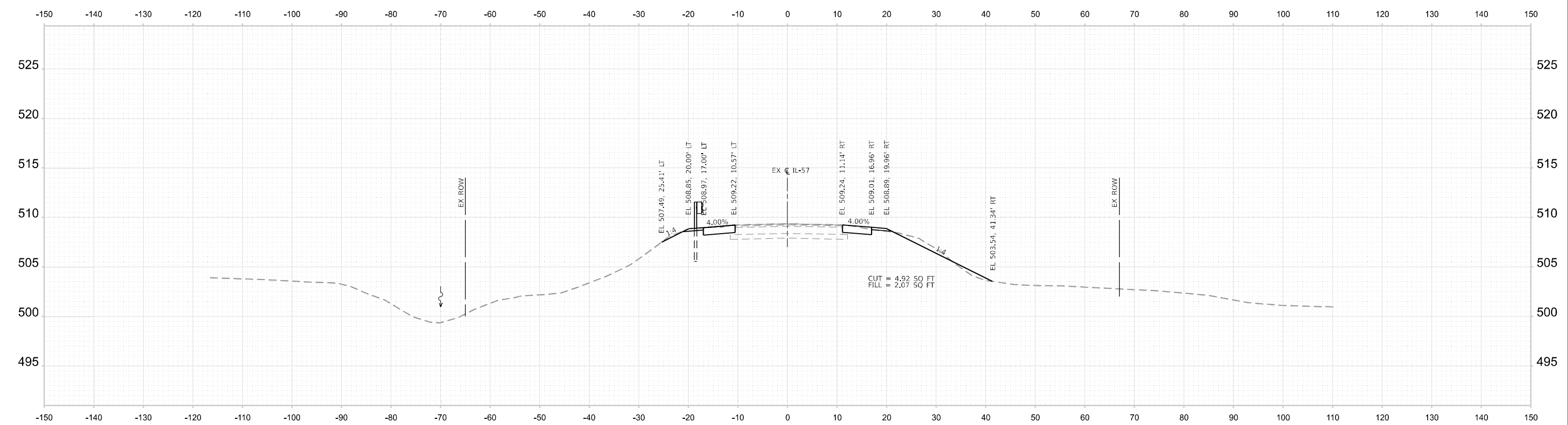

STA 109+75.49



USER NAME = 14nho	DESIGNED - NH	REVISED -
	DRAWN - NH	REVISED -
PLOT SCALE = 0.1666667 / in.	CHECKED - RC	REVISED -
PLOT DATE = 10/17/2024	DATE - 11/2024	REVISED -

STATE OF ILLINOIS  
DEPARTMENT OF TRANSPORTATION

IL RTE 57 OVER HARKNESS CREEK CROSS SECTIONS			
SCALE: 1"=10'	SHEET 7 OF 10 SHEETS	STA. 109+75.49	TO STA. 110+00.00

F.A.P. RTE.	SECTION	COUNTY	TOTAL SHEETS	SHEET NO.
502	42BR	ADAMS	38	33
				CONTRACT NO. 72G18
				ILLINOIS FED. AID PROJECT

DATE	
BY	
SURVEYED	
PLOTTED	
TEMPLATE	
AREAS	
CHECKED	
NO.	

DATE	
BY	
SURVEYED	
PLOTTED	
TEMPLATE	
AREAS	
CHECKED	
NO.	

MODEL: E:\23-110+24.17 (Sheet)  
FILE NAME: E:\23-110+24.17\CADD\_Sheets\8-23-24.dgn

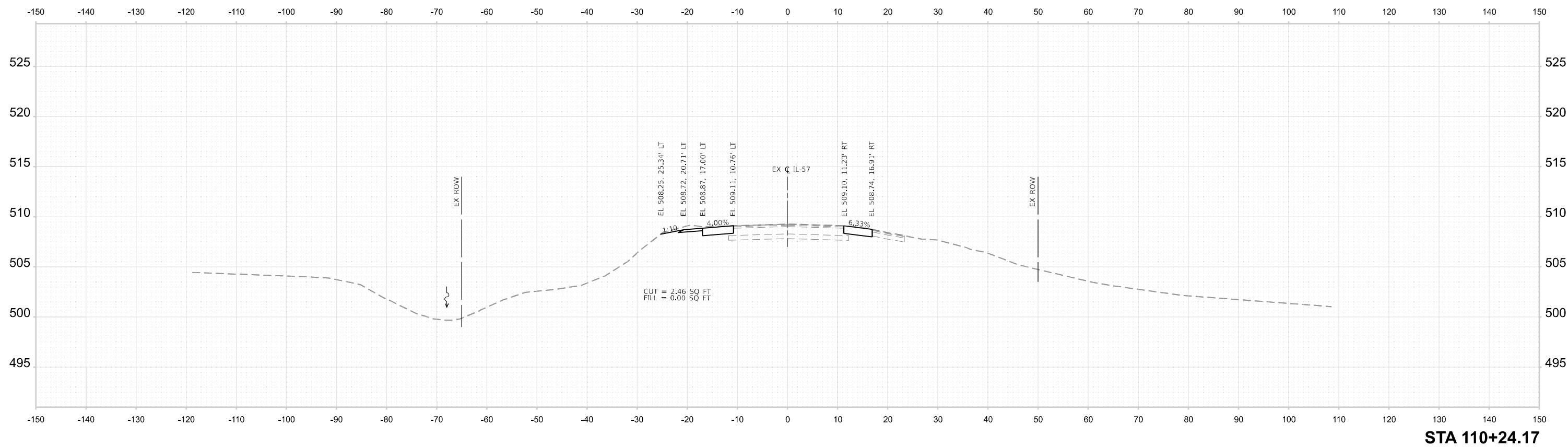
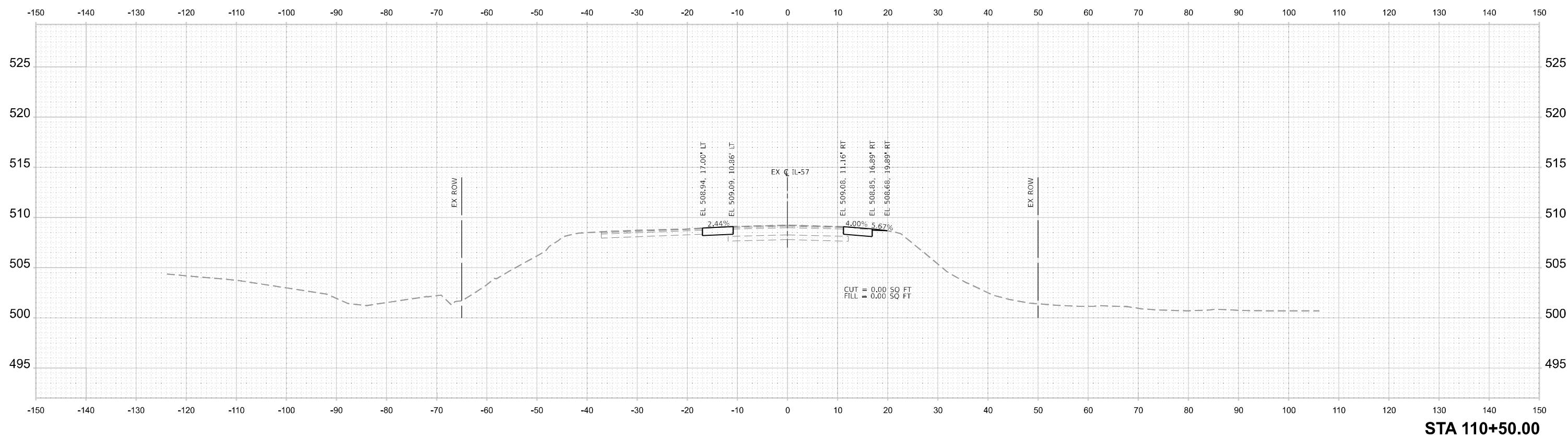

USER NAME = 14nho	DESIGNED - NH	REVISED -
	DRAWN - NH	REVISED -
PLOT SCALE = 0.16666667 / in.	CHECKED - RC	REVISED -
PLOT DATE = 10/17/2024	DATE - 11/2024	REVISED -

**STATE OF ILLINOIS  
DEPARTMENT OF TRANSPORTATION**

<b>IL RTE 57 OVER HARKNESS CREEK CROSS SECTIONS</b>			
SCALE: 1"=10'	SHEET 8	OF 10 SHEETS	STA. 110+24.17 TO STA. 110+50.00

F.A.P. RTE.	SECTION	COUNTY	TOTAL SHEETS	SHEET NO.
502	42BR	ADAMS	38	34
CONTRACT NO. 72G18				
ILLINOIS FED. AID PROJECT				

DATE	BY
SURVEYED	PLOTTED
NOTE BOOK	AREAS CHECKED
NO.	

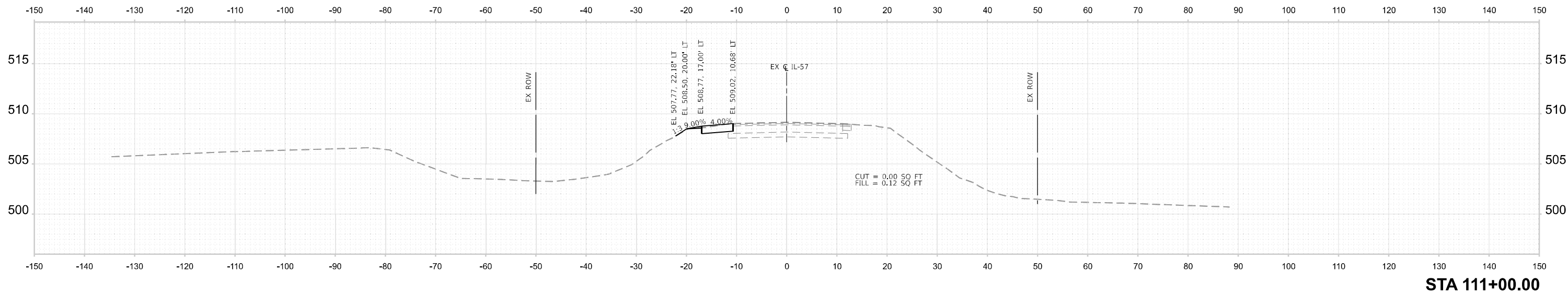

DATE	BY
SURVEYED	PLOTTED
NOTE BOOK	AREAS CHECKED
NO.	

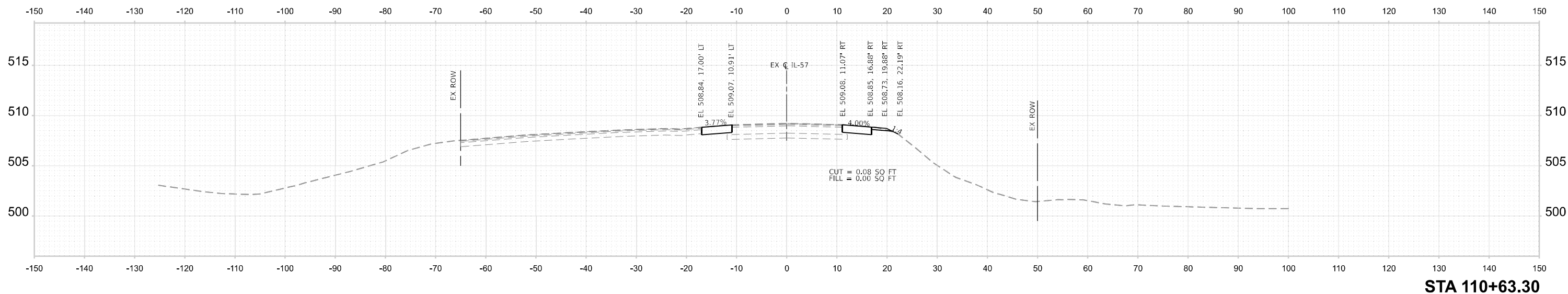

MODEL: EX03-110+63.30 [Sheet]  
FILE NAME: E:\2024\CADD\_Sheets\08\24\08.dgn

USER NAME = 14nho	DESIGNED - NH	REVISED -
	DRAWN - NH	REVISED -
PLOT SCALE = 0.1666667' / in.	CHECKED - RC	REVISED -
PLOT DATE = 10/17/2024	DATE - 11/2024	REVISED -

**STATE OF ILLINOIS  
DEPARTMENT OF TRANSPORTATION**

**IL RTE 57 OVER HARKNESS CREEK  
CROSS SECTIONS**

SCALE: 1"=10'    SHEET 9 OF 10 SHEETS    STA. 110+63.30 TO STA. 111+00.00

F.A.P. RTE.	SECTION	COUNTY	TOTAL SHEETS	SHEET NO.
502	42BR	ADAMS	38	35
CONTRACT NO. 72G18				
ILLINOIS FED. AID PROJECT				

DATE	
BY	
SURVEYED	
PLOTTED	
TEMPLATE	
NOTE BOOK	
AREAS CHECKED	
NO.	

DATE	
BY	
SURVEYED	
PLOTTED	
TEMPLATE	
NOTE BOOK	
AREAS CHECKED	
NO.	

MODEL: EX31-111+00.69 [Sheet]  
FILE NAME: E:\2031-1\CADD\_Sheets\Dr72G18-ss.dgn

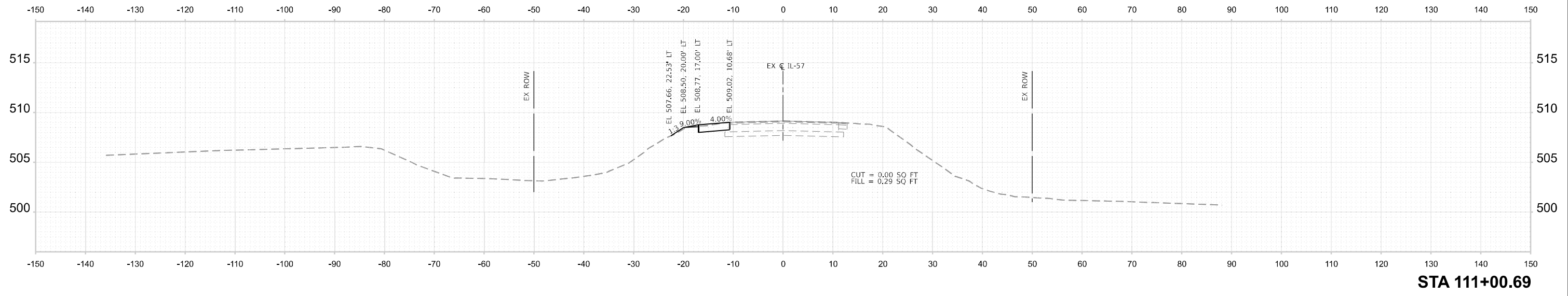
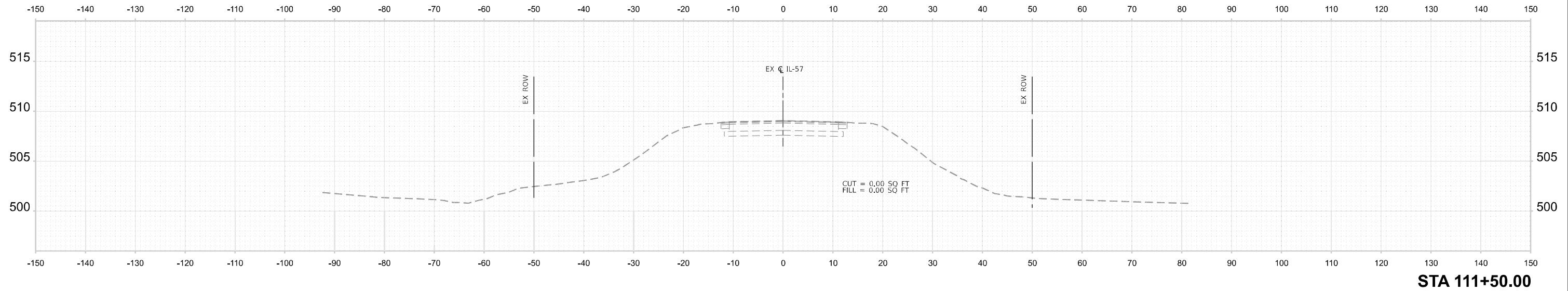

USER NAME = 14nho	DESIGNED - NH	REVISED -
	DRAWN - NH	REVISED -
PLOT SCALE = 0.1666667' / in.	CHECKED - RC	REVISED -
PLOT DATE = 10/18/2024	DATE - 11/2024	REVISED -

**STATE OF ILLINOIS  
DEPARTMENT OF TRANSPORTATION**

<b>IL RTE 57 OVER HARKNESS CREEK CROSS SECTIONS</b>			
SCALE: 1"=10'	SHEET 10	OF 10 SHEETS	TO STA. 111+50.00

F.A.P. RTE.	SECTION	COUNTY	TOTAL SHEETS	SHEET NO.
502	42BR	ADAMS	38	36
CONTRACT NO. 72G18				
ILLINOIS FED. AID PROJECT				

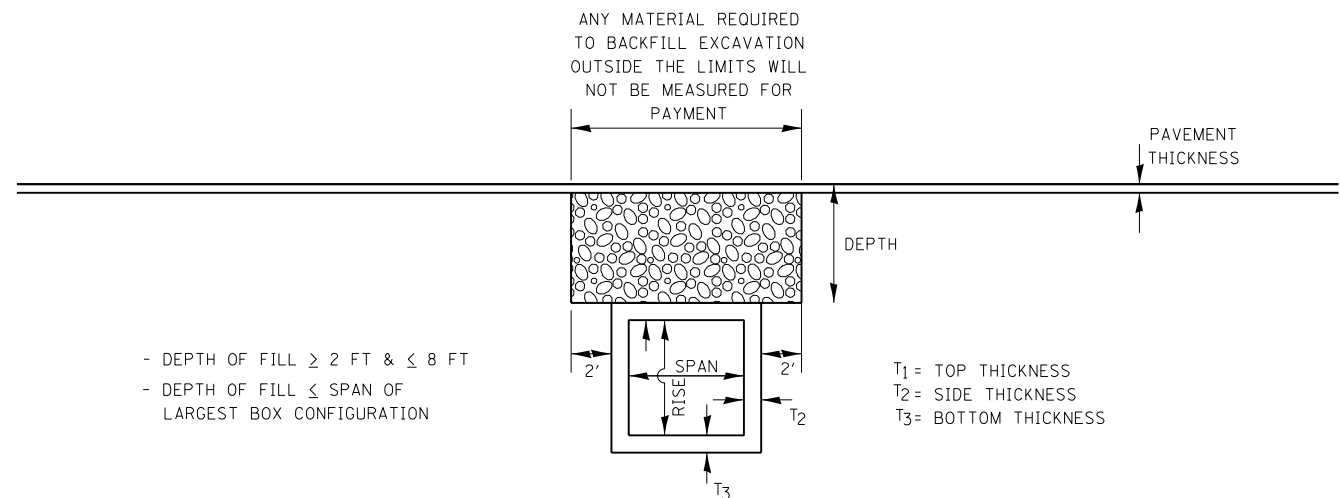

- DEPTH OF FILL  $\geq$  2 FT &  $\leq$  8 FT
- DEPTH OF FILL  $\leq$  SPAN OF LARGEST BOX CONFIGURATION

\* NOTE: WILL NEED MODIFICATION FOR MULTICELL BOX CULVERTS

### PROFILE GRANULAR BACKFILL DETAIL FOR NEW ALIGNMENTS & CONSTRUCTION

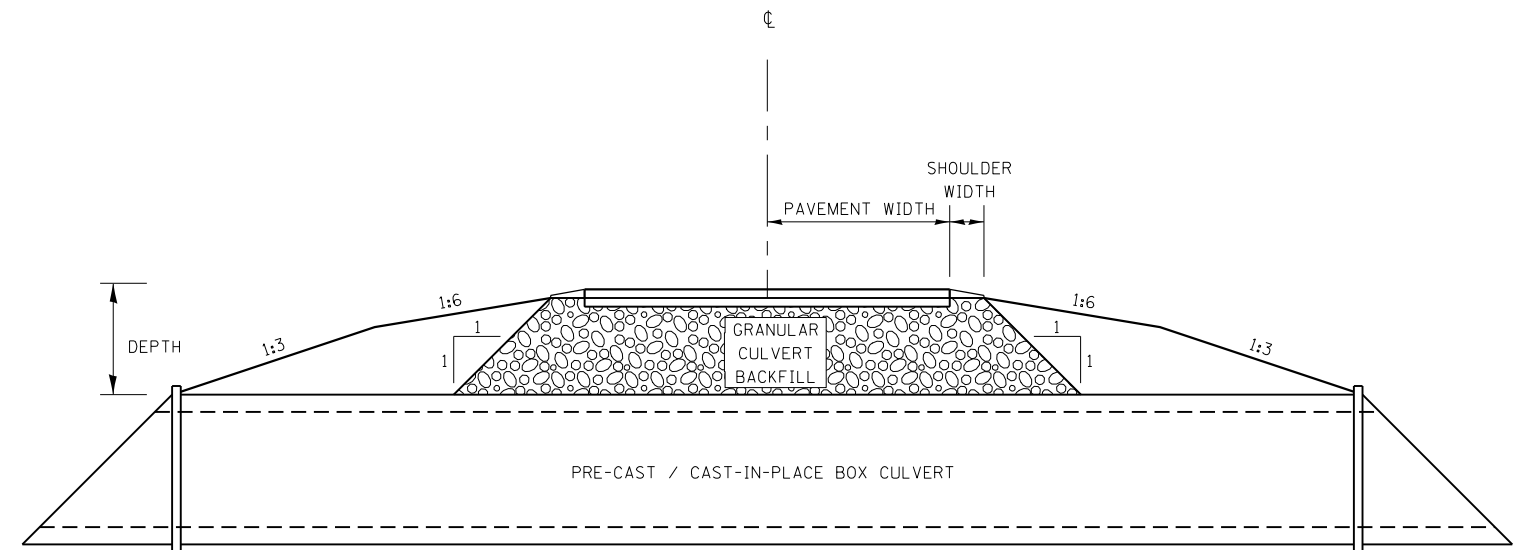

- DEPTH OF FILL  $\geq$  2 FT &  $\leq$  8 FT
- DEPTH OF FILL  $\leq$  SPAN OF LARGEST BOX CONFIGURATION

### CROSS SECTION GRANULAR BACKFILL DETAIL FOR NEW ALIGNMENTS & CONSTRUCTION

FILE NAME =	USER NAME = Verenskifa	DESIGNED - BKL	REVISED -	<b>STATE OF ILLINOIS DEPARTMENT OF TRANSPORTATION</b>	<b>GRANULAR BACKFILL DETAIL TO TOP OF BOX CULVERT</b>			F.A.P. RTE.	SECTION	COUNTY	TOTAL SHEETS	SHEET NO.
p:\11\084EBIDINTEG.illinois.gov\PIWIDOT\Documents\DOT Offices\District 6\Standards\Standard Details\200-BK\Granular Backfill Detail.dwg	PLLOT SCALE = 40.0000' / in.	CHECKED -	REVISED -					502	42BR	ADAMS	38	37
Granular Backfill Details.dgn	PLOT DATE = 7/5/2016	DATE -	REVISED -					SCALE: SHEET OF SHEETS STA. TO STA.			CONTRACT NO. 72G18	
ILLINOIS FED. AID PROJECT												

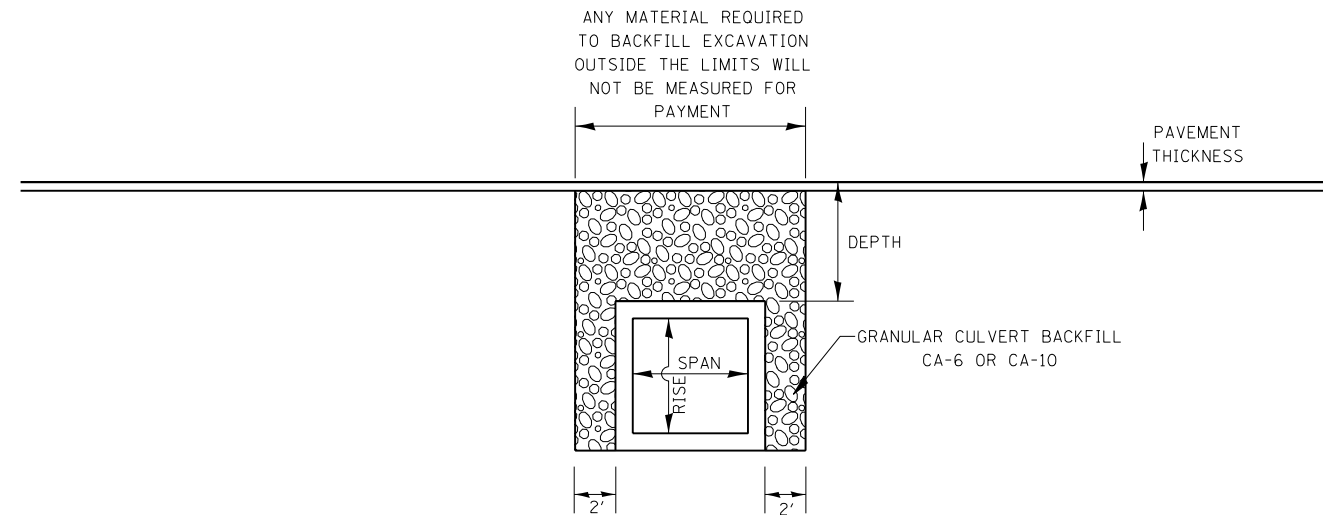

- DEPTH OF FILL  $\geq$  2 FT &  $\leq$  8 FT
- DEPTH OF FILL  $\leq$  SPAN OF LARGEST BOX CONFIGURATION

**PROFILE GRANULAR BACKFILL DETAIL  
FOR EXISTING ALIGNMENTS & CONSTRUCTION**

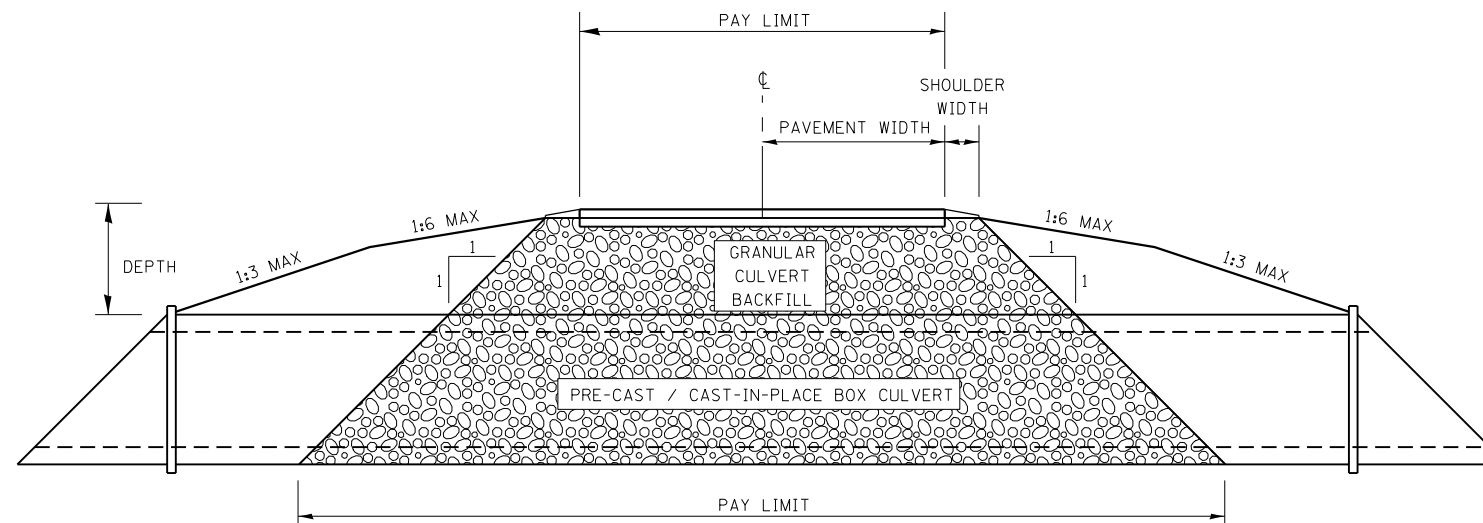

**CROSS SECTION GRANULAR BACKFILL DETAIL  
FOR EXISTING ALIGNMENTS & CONSTRUCTION**

FILE NAME =	USER NAME = Verenskif	DESIGNED - BKL	REVISED -	<b>STATE OF ILLINOIS DEPARTMENT OF TRANSPORTATION</b>	<b>GRANULAR BACKFILL DETAIL TO BOTTOM OF BOX CULVERT</b>			F.A.P. RTE.	SECTION	COUNTY	TOTAL SHEETS	SHEET NO.
p:\11084EBIDINTEG.illinois.gov\PWIDOT\Documents\DOT Offices\District 6\Standards\Standard Details\200-BK\Granular Backfill Detail.dwg	DESIGNED - BKL	REVISED -	REVISED -					502	42BR	ADAMS	38	38
Granular Backfill Details.dgn	PLOT SCALE = 40.0000' / in.	CHECKED -	REVISED -		CONTRACT NO. 72G18			ILLINOIS FED. AID PROJECT				
	PLOT DATE = 7/5/2016	DATE -	REVISED -		SCALE:	SHEET	OF	SHEETS	STA.	TO	STA.	