

F.A.J. RTE.	SECTION	COUNTY	TOTAL SHEETS	SHEET NO.
70	82-5VB-R-2	ST. CLAIR	254	1
		ILLINOIS	CONTRACT NO. 76K02	

INDEX OF SHEETS

- 1 COVER SHEET
- 2 PROJECT SEALS
- 3 HIGHWAY STANDARDS, GENERAL NOTES, COMMITMENTS, AND HMA MIXTURE REQUIREMENT TABLE
- 4-8 RAILROAD GENERAL NOTES & RAILROAD CLEARANCE ENVELOPE
- 9-16 SUMMARY OF QUANTITIES
- 17-18 TYPICAL SECTIONS
- 19-26 SCHEDULE OF QUANTITIES
- 27-29 ALIGNMENT, TIES, AND BENCHMARKS
- 30-34 PLAN, PAVEMENT MARKING, AND REMOVALS
- 35-127 TRAFFIC CONTROL AND PROTECTION PLANS
- 128-138 PLAT OF HIGHWAYS
- 139-252 STRUCTURE PLANS
- 253-254 ROADWAY DETAILS

STATE OF ILLINOIS
DEPARTMENT OF TRANSPORTATION
**PROPOSED
HIGHWAY PLANS**
FAI ROUTE 70 (I-55 /70)
SECTION 82-5VB-R-2
PROJECT NHPP-Y5Y0(871)

**REPAIRS TO THE B&O BRIDGE
(SN 082-0017)
ST. CLAIR COUNTY**

(I-55 /70)
FUNCTIONAL CLASSIFICATION: INTERSTATE
2021 ADT = 70,100
2041 ADT = 80,600
SU = 2.5%
MU = 10.4%

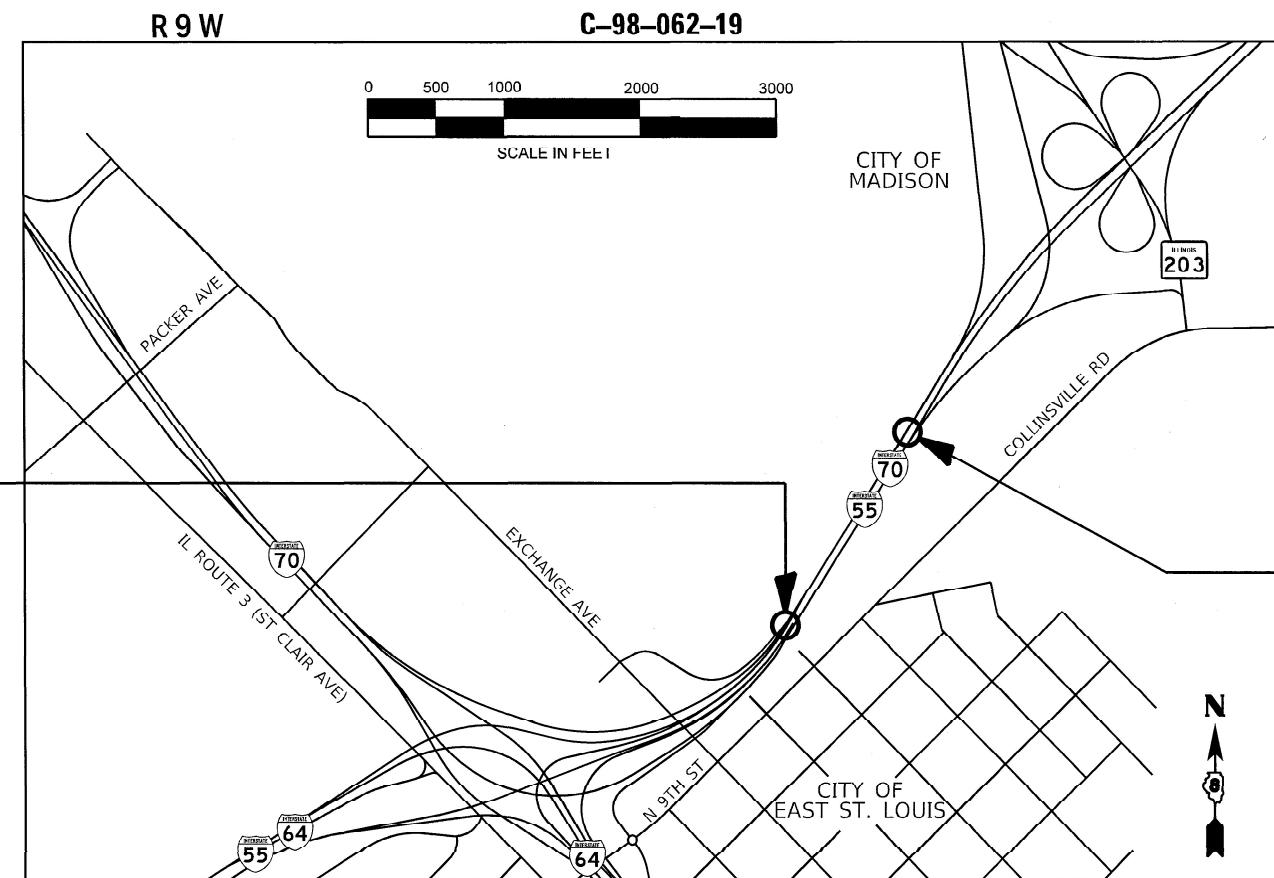
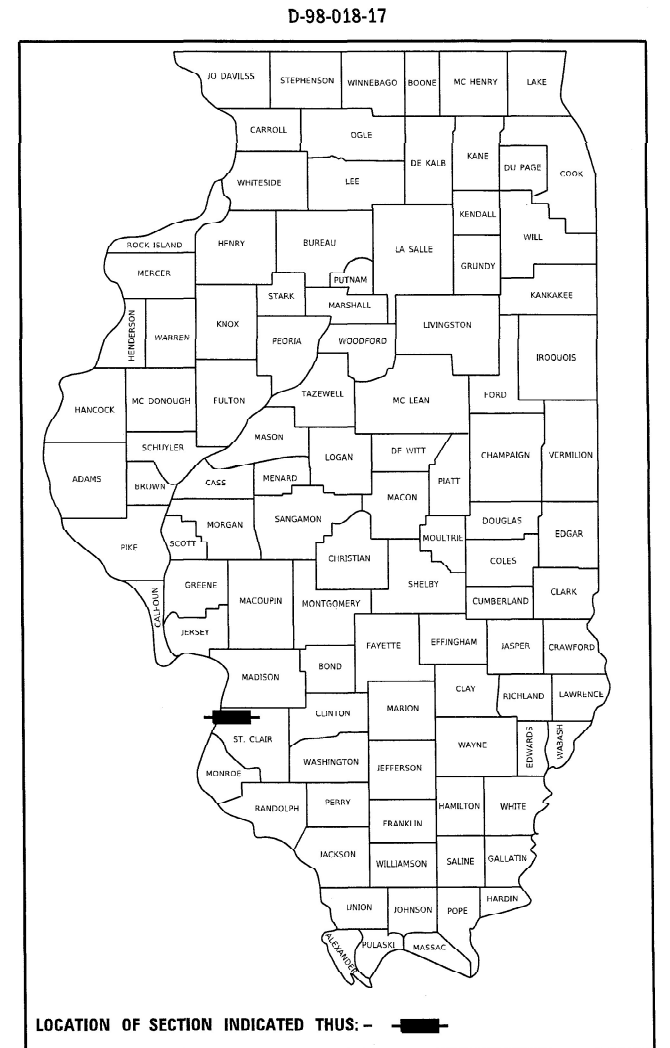

BEGIN IMPROVEMENT
STA. 71 + 19.28
LAT. + 38.635711
LONG. -90.138033

END IMPROVEMENT
STA. 92 + 98.00
LAT. + 38.640653
LONG. -90.133736

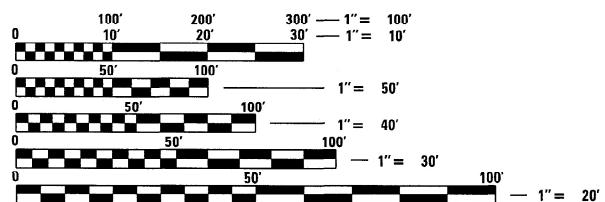

FULL SIZE PLANS HAVE BEEN PREPARED USING STANDARD ENGINEERING SCALES. REDUCED SIZED PLANS WILL NOT CONFORM TO STANDARD SCALES. IN MAKING MEASUREMENTS ON REDUCED PLANS, THE ABOVE SCALES MAY BE USED.

J.U.L.I.E.
JOINT UTILITY LOCATION INFORMATION FOR EXCAVATORS
1-800-892-0123
OR 811

GROSS LENGTH = 2178.72 FT. = 0.413 MILE
NET LENGTH = 2178.72 FT. = 0.413 MILE

PROJECT ENGINEER: BILLIE OWEN, PE

PREPARED BY
WJE ENGINEERS ARCHITECTS MATERIALS SCIENTISTS
Wiss, Janney, Elstner Associates, Inc.
EFK•Moen
Civil Engineering Design

STATE OF ILLINOIS
DEPARTMENT OF TRANSPORTATION

SUBMITTED Aug 14 2024
[Signature]
REGIONAL ENGINEER

January 31 2025
[Signature]
ENGINEER OF DESIGN AND ENVIRONMENT

January 31 2025
[Signature]
DIRECTOR OF HIGHWAYS PROJECT IMPLEMENTATION



SIGNATURE: Shelley L. Dintelman

DATE SIGNED: 8/13/2024

LICENSE EXPIRES: 11 /30 /2025

THE SEAL SHOWN ABOVE IS VALID FOR THE FOLLOWING SHEETS IN THESE PLANS WHICH WERE PREPARED UNDER MY DIRECT SUPERVISION; SHEETS 1-127 AND 253-254.

EFK♦Moen
Civil Engineering Design

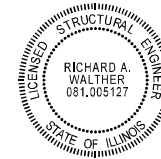

SIGNATURE: Richard A. Walther

DATE SIGNED: 8/13/2024

LICENSE EXPIRES: 11 /30 /2024

THE SEAL SHOWN ABOVE IS VALID FOR THE FOLLOWING SHEETS IN THESE PLANS WHICH WERE PREPARED UNDER MY DIRECT SUPERVISION; SHEETS 147-166, 168- 175, AND 206 - 241.

WJE | ENGINEERS
ARCHITECTS
MATERIALS SCIENTISTS
Wiss, Janney, Elstner Associates, Inc.



SIGNATURE: Alex C. Benz

DATE SIGNED: 8/13/2024

LICENSE EXPIRES: 11 /30 /2024

THE SEAL SHOWN ABOVE IS VALID FOR THE FOLLOWING SHEETS IN THESE PLANS WHICH WERE PREPARED UNDER MY DIRECT SUPERVISION; SHEETS 139-146, 167, 176- 205, AND 242-252.

EFK♦Moen
Civil Engineering Design

MODEL: D:\efk\h
FILE NAME: Z:\13052-29 B&O BR Bridge\DCN\Design\Final\Figures\02-0876K02-sht.dwg Seal.dgn

EFK♦Moen
Civil Engineering Design

USER NAME = zWaters	DESIGNED - SJF	REVISED -
	DRAWN - SJF	REVISED -
PLOT SCALE = 20,0000 * / in.	CHECKED - SLD	REVISED -
PLOT DATE = 8/13/2024	DATE - 8/13/2024	REVISED -

STATE OF ILLINOIS
DEPARTMENT OF TRANSPORTATION

PROJECT SEALS

SCALE: N/A SHEET 1 OF 1 SHEETS STA. TO STA.

F.A.I. RTE.	SECTION	COUNTY	TOTAL SHEETS	SHEET NO.
70	82-5V8-R-2	ST. CLAIR	254	2
CONTRACT NO. 76K02				
ILLINOIS FED. AID PROJECT				

METRO EAST SANITARY DISTRICT

1. WITHIN THESE NOTES, THE METRO EAST SANITARY DISTRICT SHALL BE REFERRED TO AS "MESD".
2. A CONTRACTORS' RIGHT-OF-ENTRY PERMIT IS REQUIRED BEFORE ANY WORK CAN COMMENCE ON MESD PROPERTY. THE COST TO OBTAIN THESE PERMITS SHALL BE CONSIDERED INCLUDED IN THE CONTRACT.
3. ALL BELOW GRADE WORK IN SPANS 10 THROUGH 19 ASSOCIATED WITH PIER RECONSTRUCTION AT PIERS 10, 13, AND 16 (INCLUDING TEMPORARY SUPPORT SYSTEM FOUNDATIONS) MUST BE APPROVED BY MESD.
4. THE DRAINAGE DITCH BETWEEN PIER 13 AND 14 SHALL REMAIN OPEN.
5. THE PRIMARY MESD POINT OF CONTACT FOR THIS PROJECT IS:

JUSTIN ROEHR
 SUPERINTENDENT
 MAINTENANCE OF PUMP STATIONS
 METRO EAST SANITARY DISTRICT
 1800 EDISON AVENUE
 GRANITE CITY, IL 62040
 618-452-9400 (O)
 618-363-7057 (M)
 JUSTIN@MESDONLINE.ORG

CSX TRANSPORTATION, INC. GENERAL NOTES

1. WITHIN THESE NOTES, THE CSX TRANSPORTATION, INC. SHALL BE REFERRED TO AS "CSXT".
2. A CONTRACTORS' RIGHT-OF-ENTRY PERMIT IS REQUIRED BEFORE ANY WORK CAN COMMENCE ON CSXT PROPERTY. THE COST TO OBTAIN THESE PERMITS SHALL BE CONSIDERED INCLUDED IN THE CONTRACT.
3. ALL WORK WITH A POTENTIAL TO FOUL THE TRACK WILL REQUIRE A CSXT FLAGMAN. A MINIMUM 72 HOURS NOTICE IS REQUIRED TO SCHEDULE A FLAGMAN FOR WORK. CSXT FLAGGING WILL BE PAID FOR ACCORDING TO ARTICLE 109.05 OF THE STANDARD SPECIFICATIONS. WHEN TRAINS ARE PASSING THE SITE, ALL WORK WITHIN 50 FEET OF THE TRACK MUST BE DISCONTINUED UNTIL THE TRAIN HAS PASSED. ALL WORKERS AT GROUND LEVEL ARE REQUIRED TO CLEAR A MINIMUM OF 25 FEET (HORIZONTAL) AWAY FROM TRACKS WHILE TRAINS ARE PASSING.
4. THE PRIMARY CSXT POINTS OF CONTACT FOR THIS PROJECT ARE:

 BRAD ARMSTRONG
 PROJECT MANAGER - PUBLIC PROJECTS
 CSX TRANSPORTATION, INC.
 4802 DECOURSEY PIKE
 TAYLOR MILL, KY 41015
 513.853.1221
 BRAD_ARMSTRONG@CSX.COM

 CLAYTON SHOWMAN
 PUBLIC PROJECT MANAGER
 225 WATER STREET, SUITE 1510
 JACKSONVILLE, FL 32202
 904.491.2917
 CSHOWMAN@BENESCH.COM
5. ALL EMAIL CORRESPONDENCE WITH CSXT SHOULD REFERENCE THE FOLLOWING IN THE SUBJECT LINE: "CSX OP# IL0572"
6. REFER TO THE CSXT PUBLIC PROJECT INFORMATION MANUAL FOR ADDITIONAL REQUIREMENTS NEEDED FOR WORKING ON/ABOVE/ADJACENT TO CSXT. SPECIFIC SECTIONS THAT PERTAIN TO THIS PROJECT ARE: SPECIAL PROVISIONS FOR CONSTRUCTION NEAR CSXT PROPERTY, OVERHEAD BRIDGE CRITERIA, CONSTRUCTION SUBMISSION CRITERIA, SOIL AND WATER MANAGEMENT POLICY, AND INSURANCE REQUIREMENTS FOR PUBLIC PROJECTS.
7. CONTRACTOR ACCESS WILL BE LIMITED TO THE IMMEDIATE PROJECT AREA ONLY. THE CSXT RIGHT-OF-WAY OUTSIDE THE PROJECT AREA MAY NOT BE USED FOR CONTRACTOR ACCESS TO THE PROJECT SITE AND NO TEMPORARY AT-GRADE CROSSINGS WILL BE ALLOWED.
8. IF CONTRACTOR HAS THE POTENTIAL TO PENETRATE THE DECK DURING THE DECK REHABILITATION WORK, THEN CONTRACTOR WILL BE REQUIRED TO INSTALL FALSEWORK/DEMO SHIELD PROTECTION DIRECTLY OVER THE CSXT RAILROAD SPAN. THE FALSEWORK/DEMO SHIELD PROTECTION WILL BE INSTALLED PRIOR TO THE DECK BEING PENETRATED AND WILL STAY IN PLACE FOR THE DURATION OF THE CONSTRUCTION ACTIVITIES. THE FALSEWORK/DEMO SHIELD SHALL BE DESIGNED AND CONSTRUCTED IN ACCORDANCE TO CSXT'S CONSTRUCTION SUBMISSION CRITERIA.
9. THE CONTRACTOR MAY NOT USE CSXT RIGHT-OF-WAY FOR STORAGE OF MATERIALS OR EQUIPMENT DURING CONSTRUCTION WITHOUT PRIOR CSXT APPROVAL. THE CSXT RIGHT-OF-WAY MUST REMAIN CLEAR FOR RAILROAD USE AT ALL TIMES. EQUIPMENT MAY NOT BE POSITIONED TO BLOCK THE RAILROAD ACCESS ROAD, TRACK AREA OR ANY PART OF THE CSXT RIGHT-OF-WAY WITHOUT PRIOR CSXT APPROVAL.
10. TEMPORARY CONSTRUCTION CLEARANCE - ENSURE ALL FALSEWORK, BRACING OR FORMS HAVE A MINIMUM HORIZONTAL CLEARANCE OF 12 FEET MEASURED PERPENDICULAR TO THE CENTERLINE OF THE NEAREST TRACK, AND A MINIMUM VERTICAL CLEARANCE OF 22 FEET AS MEASURED FROM THE TOP OF RAIL PROFILE.
11. THE CONTRACTOR WILL BE REQUIRED TO ABIDE BY THE PROVISIONS OF THE AGENCY/CSXT CONSTRUCTION AGREEMENT. PERIODICALLY, THROUGHOUT THE PROJECT DURATION, THE CONTRACTOR WILL BE REQUIRED TO MEET, DISCUSS AND, IF NECESSARY, TAKE IMMEDIATE ACTION AT THE DISCRETION OF CSXT PERSONNEL AND/OR THEIR AUTHORIZED REPRESENTATIVE, TO COMPLY WITH PROVISIONS OF THAT AGREEMENT AND THESE SPECIFICATIONS
12. UPON COMPLETION OF THE WORK ON CSXT PROPERTY, THE CONTRACTOR SHALL REQUEST THE OWNER TO ARRANGE A FINAL INSPECTION OF THE PROJECT WITH THE RAILROAD'S PROJECT ENGINEER OR HIS AUTHORIZED REPRESENTATIVE.
13. CSXT SHALL BE NOTIFIED AT LEAST 5 DAYS IN ADVANCE OF THE PRE-CONSTRUCTION MEETING.
14. CSXT HAS SOLE AUTHORITY TO DETERMINE THE NEED FOR TRACK PROTECTION REQUIRED TO PROTECT ITS OPERATIONS AND PROPERTY. IN GENERAL, TRACK PROTECTION WILL BE REQUIRED WHENEVER CONTRACTOR OR EQUIPMENT ARE, OR ARE LIKELY TO BE, WORKING WITHIN FIFTY FEET OF TRACK OR OTHER TRACK CLEARANCES AS SPECIFIED BY CSXT.
15. ALL WASTE MATERIALS GENERATED BY THIS PROJECT, INCLUDING BUT NOT LIMITED TO WASHING WITH WATER, CLEANING SOLVENTS, BLASTING, SCRAPING, BRUSHING AND PAINTING OPERATIONS, SHALL BE THE RESPONSIBILITY OF THE PROJECT SPONSOR OR ITS CONTRACTOR AND SHALL BE CONTAINED, COLLECTED AND PROPERLY DISPOSED OF BY THE PROJECT SPONSOR OR ITS CONTRACTOR. THE PROJECT SPONSOR AND ITS CONTRACTOR AGREE TO FULLY COMPLY WITH ALL FEDERAL, STATE, AND LOCAL ENVIRONMENTAL LAWS, REGULATIONS, STATUTES AND ORDINANCES AT ALL TIMES.

CSX TRANSPORTATION, INC. GENERAL NOTES (CONT.)

16. IF USING SCAFFOLDING OR SAFETY CABLES/HARNESSES FOR PAINTING SUPPORTING CALCULATIONS FOR THEIR DESIGN MUST BE PROVIDED. PLANS MUST BE STAMPED AND SEALED BY A LICENSED PROFESSIONAL ENGINEER IN THE STATE IN WHICH THE PROJECT IS TO OCCUR. PROVIDE SPEC SHEETS FOR SCAFFOLDING, HARNESSES, SAFETY CABLES, ETC., TO BE USED.
17. IT IS THE POLICY OF CSXT THAT ALL MATERIALS DISCARDED BE MANAGED IN ACCORDANCE WITH LOCAL, STATE AND FEDERAL REGULATIONS AS WELL AS CSXT'S BEST MANAGEMENT PRACTICES AND SUSTAINABILITY GOALS. TO ENSURE THAT THESE GOALS ARE ACHIEVED, CSXT HAS MECHANISMS IN PLACE TO MONITOR WASTE MANAGEMENT ACTIVITIES, CAPTURE THE INFORMATION NECESSARY TO ENSURE 100% COMPLIANCE WITH LOCAL, STATE AND FEDERAL REQUIREMENTS 100% OF THE TIME, AND TRACK PROGRESS IN THE CSXT SUSTAINABILITY PROGRAM. THESE MECHANISMS ALSO ALLOW CSXT TO COMPLETE REPORTING REQUIREMENTS TO FEDERAL AND STATE REGULATORY AGENCIES AND DOCUMENT CSXT'S PROGRESS TOWARD ITS SUSTAINABILITY GOALS. WASTE MATERIAL REMOVAL SHALL BE IN ACCORDANCE WITH CSXT SOIL AND WATER MANAGEMENT POLICY.

CSX TRANSPORTATION PROTECTIVE SYSTEM NOTES:

1. THE CONTRACTOR SHALL INSTALL A GEOTEXTILE FABRIC BALLAST PROTECTION SYSTEM TO PREVENT CONSTRUCTION OR DEMOLITION DEBRIS AND FINES FROM FOULING THE BALLAST. THE GEOTEXTILE BALLAST PROTECTION SYSTEM SHALL BE INSTALLED AND MAINTAINED BY THE CONTRACTOR TO THE SATISFACTION OF THE ENGINEER.
2. THE CONTRACTOR SHALL SUBMIT DETAILED PLANS, WITH SUPPORTING CALCULATIONS, OF THE PROTECTION SHIELD AND BALLAST PROTECTION SYSTEMS FOR APPROVAL PRIOR TO THE START OF DEMOLITION.
3. THE SYSTEM SHALL EXTEND ALONG THE TRACK STRUCTURE FOR A MINIMUM OF 25' BEYOND THE LIMITS OF THE DEMOLITION WORK, OR FARTHER IF REQUIRED BY CSXT.
4. A FLAGMAN WILL BE NEEDED ANYTIME THERE IS A POTENTIAL TO FOUL THE TRACK.

THE NOTES SHOWN ON THIS SHEET ARE SPECIFIC ONLY TO THE METRO EAST SANITARY DISTRICT OR CSX TRANSPORTATION, INC.

MODEL Path: \\z:\13052.29 B&O BR Bridge\DCN\Design\Final\FB\Sheet\04-06-08\76K02-CON-RR_General_Notes.dgn
 FILE NAME: Z:\13052.29 B&O BR Bridge\DCN\Design\Final\FB\Sheet\04-06-08\76K02-CON-RR_General_Notes.dgn

	USER NAME = zWaters	DESIGNED - SG	REVISED -	STATE OF ILLINOIS DEPARTMENT OF TRANSPORTATION	RAILROAD GENERAL NOTES			F.A.I. RTE.	SECTION	COUNTY	TOTAL SHEETS	SHEET NO.
	DRAWN - JRD	REVISIONS -	70					82-5V8-R-2	ST. CLAIR	254	4	
	PLOT SCALE = 20,000' / in.	CHECKED - SG	REVISED -		CONTRACT NO. 76K02							
	PLOT DATE = 8/13/2024	DATE - 8/13/2024	REVISED -		SCALE: N/A	SHEET 1 OF 5 SHEETS	STA.	TO STA.	ILLINOIS FED. AID PROJECT			

NOTE: ALL CLEARANCES APPLY TO BOTH EXISTING AND PROPOSED CONSTRUCTION.

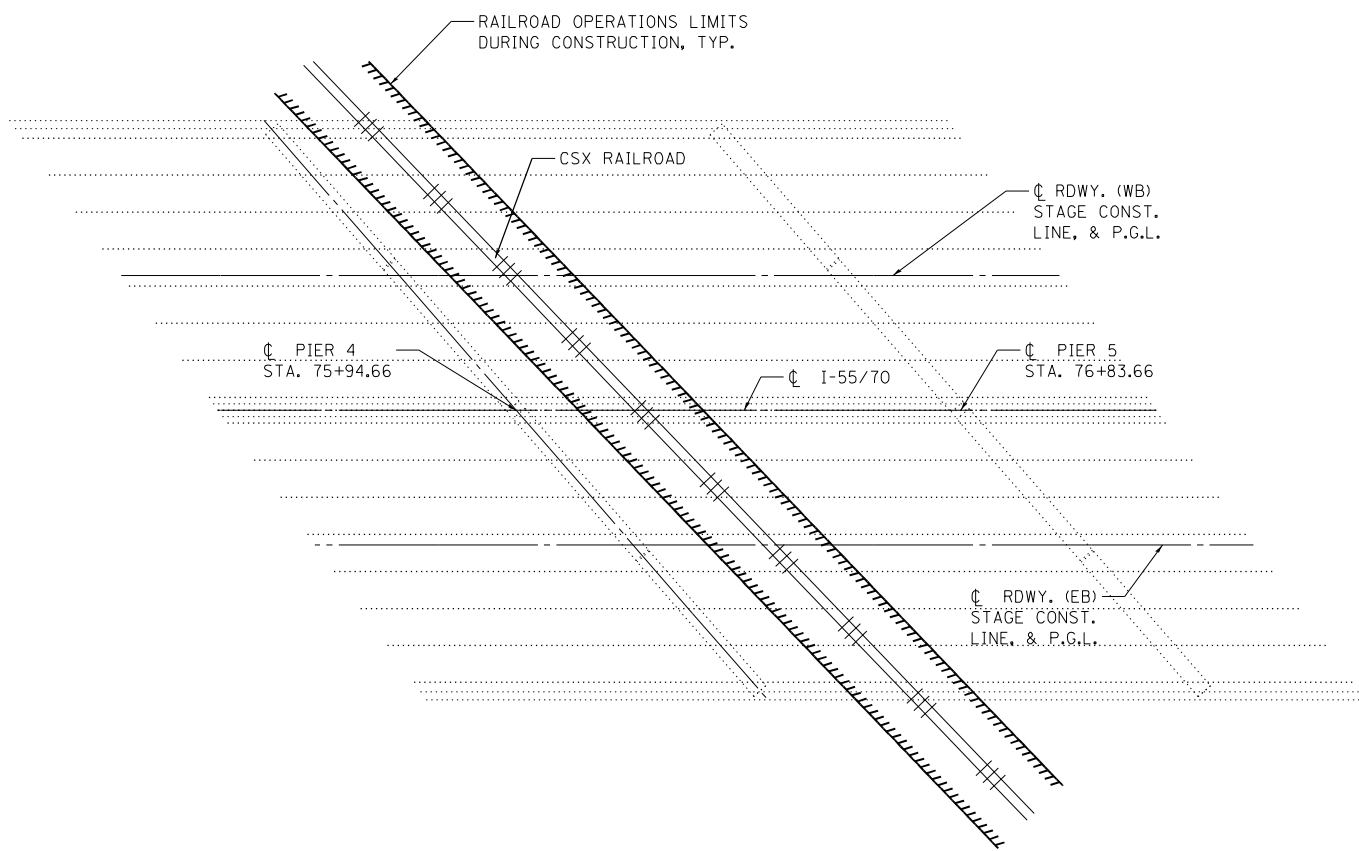
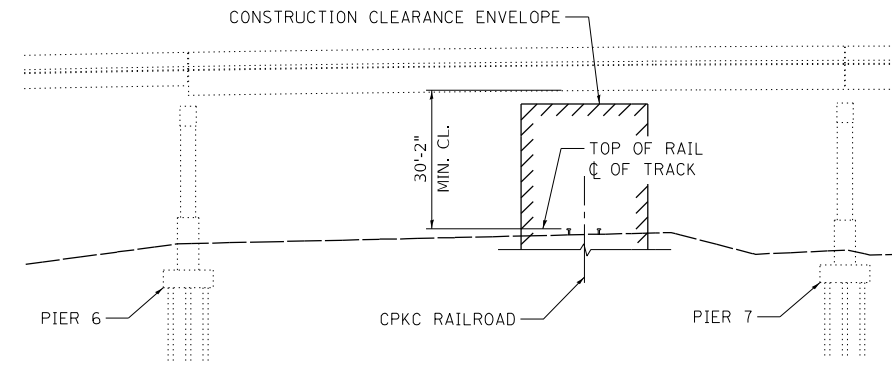
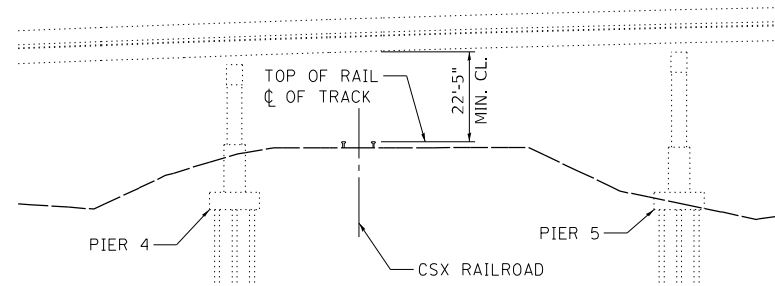

SPAN 5 (PIERS 4 & 5) CLEARANCE ENVELOPE

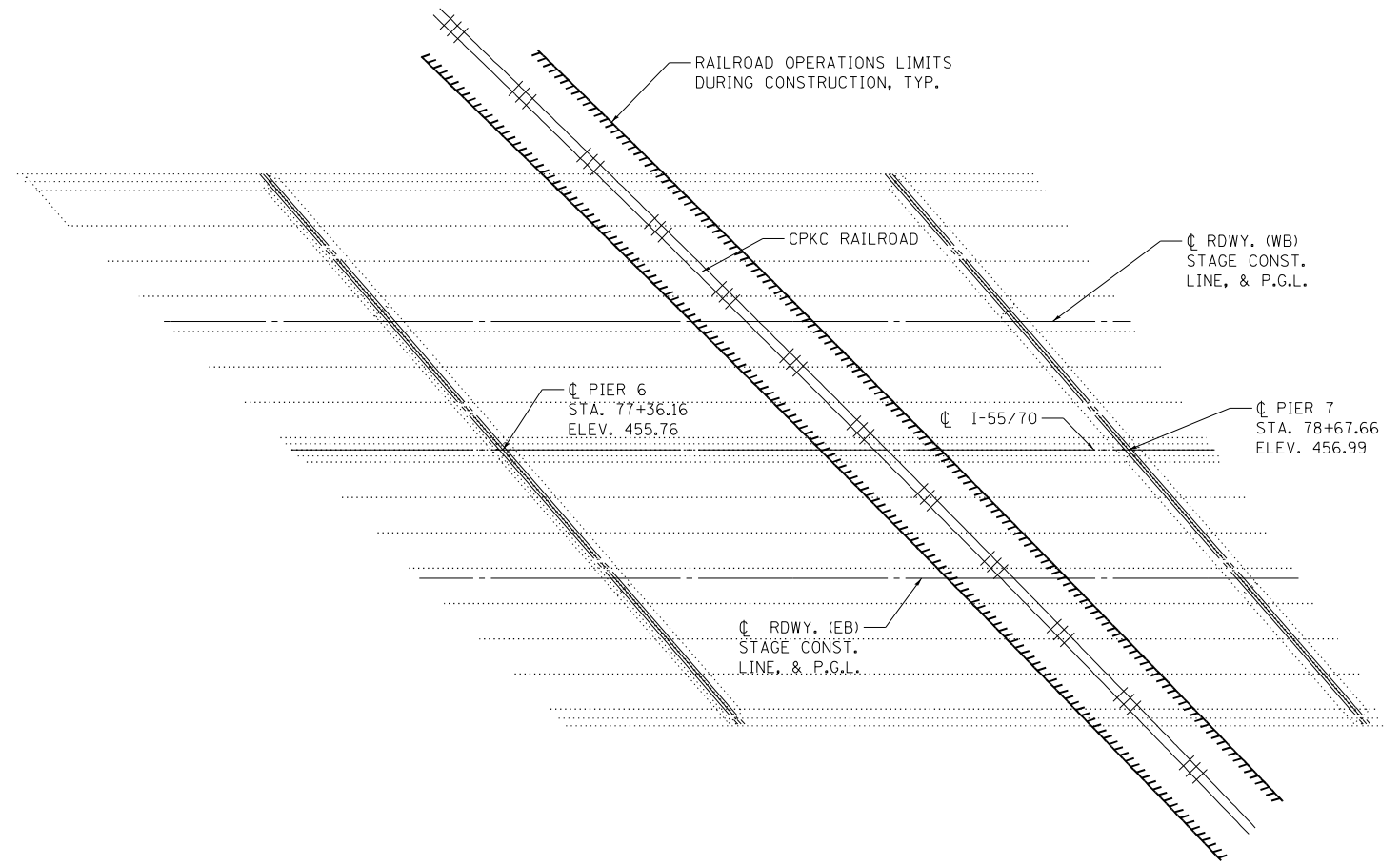

SPAN 7 (PIERS 6 & 7) CLEARANCE ENVELOPE

MODEL: D:\efk\... FILE NAME: 2413052-29_B&O_BR_Bridge\DCN\Design\Final\Final\Sheet\07_456287800-CHK-RR.dgn

EFK Moen
Civil Engineering Design

USER NAME = zWaters	DESIGNED - SG	REVISED -
PLOT SCALE = 20,000' / in.	DRAWN - SJF	REVISED -
PLOT DATE = 8/13/2024	CHECKED - SG	REVISED -
	DATE - 8/13/2024	REVISED -

STATE OF ILLINOIS
DEPARTMENT OF TRANSPORTATION

RAILROAD CLEARANCE ENVELOPE	
SCALE: N/A	SHEET 4 OF 5 SHEETS
STA.	TO STA.

F.A.I. RTE.	SECTION	COUNTY	TOTAL SHEETS	SHEET NO.
70	82-5V8-R-2	ST. CLAIR	254	7
CONTRACT NO. 76K02				
ILLINOIS FED. AID PROJECT				

CODE NO.	ITEM	UNIT	TOTAL QUANTITY	CONSTRUCTION CODE	
				90% FEDERAL 10% STATE	
				BRIDGE	
				0013 SN 082-0017	
20800150	TRENCH BACKFILL	CU YD	2	2	
21001000	GEO TECHNICAL FABRIC FOR GROUND STABILIZATION	SQ YD	588	588	
28000400	PERIMETER EROSION BARRIER	FOOT	331	331	
28100105	STONE RIPRAP, CLASS A3	SQ YD	6	6	
35101100	AGGREGATE BASE COURSE, TYPE A 12"	SQ YD	588	588	
40600295	POLYMERIZED BITUMINOUS MATERIALS (TACK COAT)	POUND	1500	1500	
40600370	LONGITUDINAL JOINT SEALANT	FOOT	1792	1792	
40600982	HOT-MIX ASPHALT SURFACE REMOVAL - BUTT JOINT	SQ YD	2156	2156	
40605024	POLYMERIZED HOT-MIX ASPHALT SURFACE COURSE, STONE MATRIX ASPHALT, 9.5, MIX "E", N80	TON	2166	2166	
42000060	WELDED WIRE REINFORCEMENT	SQ YD	758	758	
44000152	HOT-MIX ASPHALT SURFACE REMOVAL, 3/4"	SQ YD	1171	1171	
44004250	PAVED SHOULDER REMOVAL	SQ YD	973	973	
48102100	AGGREGATE WEDGE SHOULDER, TYPE B	TON	7	7	
48203037	HOT-MIX ASPHALT SHOULDERS, 10"	SQ YD	886	886	

MODEL Path: \\z:\13052-29 B&O BR Bridge\DCN\Design\Final\Bridges\09-15-08\76K02-INT-500.dgn
 FILE NAME: Z:\13052-29 B&O BR Bridge\DCN\Design\Final\Bridges\09-15-08\76K02-INT-500.dgn



USER NAME = zWaters	DESIGNED - SJF	REVISED
DRAWN - ZJB	CHECKED - SLD	REVISED -
PLOT SCALE = 20,000' / in.	DATE - 8/13/2024	REVISED -
PLOT DATE = 8/13/2024		

STATE OF ILLINOIS
DEPARTMENT OF TRANSPORTATION

SCALE: N/A		SHEET 1 OF 8 SHEETS		STA.	TO STA.
------------	--	---------------------	--	------	---------

F.A.I. RTE.	SECTION	COUNTY	TOTAL SHEETS	SHEET NO.
70	82-5V8-R-2	ST. CLAIR	254	9
			CONTRACT NO. 76K02	
		ILLINOIS FED. AID PROJECT		

CODE NO.	ITEM	UNIT	TOTAL QUANTITY	CONSTRUCTION CODE	
				90% FEDERAL 10% STATE	
				BRIDGE	
				0013 SN 082-0017	
48300715	PORTLAND CEMENT CONCRETE SHOULDERS, 12 3/4"	SQ YD	39	39	
50102400	CONCRETE REMOVAL	CU YD	267.2	267.2	
50157300	PROTECTIVE SHIELD	SQ YD	1914	1914	
50300225	CONCRETE STRUCTURES	CU YD	1649.8	1649.8	
50300255	CONCRETE SUPERSTRUCTURE	CU YD	309.2	309.2	
50500405	FURNISHING AND ERECTING STRUCTURAL STEEL	POUND	12600	12600	
50800205	REINFORCEMENT BARS, EPOXY COATED	POUND	317540	317540	
50800515	BAR SPLICERS	EACH	544	544	
52000027	PREFORMED JOINT SEAL 2 1/4"	FOOT	1655	1655	
52000110	PREFORMED JOINT STRIP SEAL	FOOT	1296	1296	
52100010	ELASTOMERIC BEARING ASSEMBLY, TYPE I	EACH	192	192	
52100540	ANCHOR BOLTS, 1 1/2"	EACH	512	512	
54213447	END SECTIONS 12"	EACH	3	3	
550A0340	STORM SEWERS, CLASS A, TYPE 2 12"	FOOT	134	134	

MODEL Path: \\...
 FILE NAME: 2413092.29 B&O BR BridgeDCN\Design\Final\B&O-150878K02-INT-500.dgn



USER NAME = zWaters	DESIGNED - SJF	REVISED
DRAWN - ZJB	CHECKED - SLD	REVISED -
PLOT SCALE = 20,000' / in.	DATE - 8/13/2024	REVISED -
PLOT DATE = 8/13/2024		

**STATE OF ILLINOIS
DEPARTMENT OF TRANSPORTATION**

SUMMARY OF QUANTITIES

SCALE: N/A SHEET 2 OF 8 SHEETS STA. TO STA.

F.A.I. RTE.	SECTION	COUNTY	TOTAL SHEETS	SHEET NO.
70	82-5V8-R-2	ST. CLAIR	254	10
			CONTRACT NO. 76K02	
ILLINOIS FED. AID PROJECT				

CODE NO.	ITEM	UNIT	TOTAL QUANTITY	CONSTRUCTION CODE	
				90% FEDERAL 10% STATE	
				BRIDGE	
				0013 SN 082-0017	
58700300	CONCRETE SEALER	SQ FT	36774	36774	
60260100	INLETS TO BE ADJUSTED	EACH	1	1	
60500060	REMOVING INLETS	EACH	3	3	
61000050	CONCRETE THRUST BLOCKS	EACH	3	3	
61000115	TYPE E INLET BOX, STANDARD 610001	EACH	3	3	
* 63000001	STEEL PLATE BEAM GUARDRAIL, TYPE A, 6 FOOT POSTS	FOOT	375	375	
* 63100045	TRAFFIC BARRIER TERMINAL, TYPE 2	EACH	1	1	
* 63100070	TRAFFIC BARRIER TERMINAL, TYPE 5	EACH	1	1	
* 63100085	TRAFFIC BARRIER TERMINAL, TYPE 6	EACH	1	1	
* 63100167	TRAFFIC BARRIER TERMINAL, TYPE 1 (SPECIAL) TANGENT	EACH	1	1	
63200310	GUARDRAIL REMOVAL	FOOT	493	493	
63801000	CONCRETE GLARE SCREEN	FOOT	356	356	
64200116	SHOULDER RUMBLE STRIPS, 16 INCH	FOOT	383	383	
66201120	CONCRETE SHOULDER CURB	FOOT	79	79	

* SPECIALTY ITEM

MODEL: D:\efk\h
 FILE NAME: 241309229 B&O BR Bridge\DCN\Design\Final\FB\FBSheet09-16-0876K02-int-500.dwg



USER NAME = zWaters	DESIGNED - SJF	REVISED
DRAWN - ZJB	CHECKED - SLD	REVISED -
PLOT SCALE = 20,000' / in.	DATE - 8/13/2024	REVISED -
PLOT DATE = 8/13/2024		

STATE OF ILLINOIS
DEPARTMENT OF TRANSPORTATION

SCALE: N/A		SHEET 3 OF 8 SHEETS	STA. TO STA.
------------	--	---------------------	--------------

F.A.I. RTE.	SECTION	COUNTY	TOTAL SHEETS	SHEET NO.
70	82-5V8-R-2	ST. CLAIR	254	11
CONTRACT NO. 76K02				
ILLINOIS FED. AID PROJECT				

CODE NO.	ITEM	UNIT	TOTAL QUANTITY	CONSTRUCTION CODE	
				90% FEDERAL 10% STATE	
				BRIDGE	
				0013 SN 082-0017	
66600105	FURNISHING AND ERECTING RIGHT OF WAY MARKERS	EACH	5	5	
* 66900200	NON-SPECIAL WASTE DISPOSAL	CU YD	238	238	
* 66900530	SOIL DISPOSAL ANALYSIS	EACH	1	1	
* 66901001	REGULATED SUBSTANCES PRE-CONSTRUCTION PLAN	L SUM	1	1	
* 66901003	REGULATED SUBSTANCES FINAL CONSTRUCTION REPORT	L SUM	1	1	
* 66901006	REGULATED SUBSTANCES MONITORING	CAL DA	20	20	
67100100	MOBILIZATION	L SUM	1	1	
70107005	PAVEMENT MARKING BLACKOUT TAPE, 5"	FOOT	19301	19301	
70107007	PAVEMENT MARKING BLACKOUT TAPE, 7"	FOOT	1220	1220	
70107009	PAVEMENT MARKING BLACKOUT TAPE, 9"	FOOT	11747	11747	
70107025	CHANGEABLE MESSAGE SIGN	CAL DA	1428	1428	
70200100	NIGHTTIME WORK ZONE LIGHTING	L SUM	1	1	
70300100	SHORT TERM PAVEMENT MARKING	FOOT	1445	1445	
70300150	SHORT TERM PAVEMENT MARKING REMOVAL	SQ FT	54660	54660	

* SPECIALTY ITEM

MODEL Path: \\...
 FILE NAME: 241309229 B&C BR BridgeDCN\Design\Final\Sheet\09-16-08\76K02-INT-500.dgn



USER NAME = zWaters	DESIGNED - SJF	REVISED
DRAWN - ZJB	CHECKED - SLD	REVISED -
PLOT SCALE = 20,000' / in.	DATE - 8/13/2024	REVISED -
PLOT DATE = 8/13/2024		

STATE OF ILLINOIS
DEPARTMENT OF TRANSPORTATION

SCALE: N/A		SHEET 4 OF 8 SHEETS	STA. TO STA.
------------	--	---------------------	--------------

SUMMARY OF QUANTITIES

F.A.I. RTE.	SECTION	COUNTY	TOTAL SHEETS	SHEET NO.
70	82-5V8-R-2	ST. CLAIR	254	12
			CONTRACT NO. 76K02	
			ILLINOIS FED. AID PROJECT	

CODE NO.	ITEM	UNIT	TOTAL QUANTITY	CONSTRUCTION CODE	
				90% FEDERAL 10% STATE	
				BRIDGE	
				0013 SN 082-0017	
70307130	TEMPORARY PAVEMENT MARKING - LINE 6" - TYPE IV TAPE	FOOT	73227	73227	
70400100	TEMPORARY CONCRETE BARRIER	FOOT	7537.5	7537.5	
70400200	RELOCATE TEMPORARY CONCRETE BARRIER	FOOT	5100	5100	
70600251	IMPACT ATTENUATORS, TEMPORARY (NON-REDIRECTIVE, NARROW), TEST LEVEL 3	EACH	7	7	
70600352	IMPACT ATTENUATORS, RELOCATE (NON-REDIRECTIVE, NARROW), TEST LEVEL 3	EACH	3	3	
* 72501000	TERMINAL MARKER - DIRECT APPLIED	EACH	1	1	
* 78003101	PREFORMED PLASTIC PAVEMENT MARKING, TYPE B - STANDARD - LETTERS AND SYMBOLS	SQ FT	56	56	
* 78003131	PREFORMED PLASTIC PAVEMENT MARKING, TYPE B - STANDARD - LINE 6"	FOOT	8112	8112	
* 78003141	PREFORMED PLASTIC PAVEMENT MARKING, TYPE B - STANDARD - LINE 8"	FOOT	1121	1121	
* 78011000	GROOVING FOR RECESSED PAVEMENT MARKING, LETTERS AND SYMBOLS	SQ FT	56	56	
* 78011035	GROOVING FOR RECESSED PAVEMENT MARKING 7"	FOOT	8112	8112	
* 78011045	GROOVING FOR RECESSED PAVEMENT MARKING 9"	FOOT	1121	1121	
* 78100100	RAISED REFLECTIVE PAVEMENT MARKER	EACH	249	249	
* 78200005	GUARDRAIL REFLECTORS, TYPE A	EACH	6	6	

* SPECIALTY ITEM

MODEL: D:\efk\h
 FILE NAME: Z:\13052229 B&C BR Bridge\DCN\Design\Final\Bridgect09-15\0878K02-ent-500.dgn



USER NAME = zWaters	DESIGNED - SJF	REVISED
DRAWN - ZJB	CHECKED - SLD	REVISED -
PLOT SCALE = 20,000' / in.	DATE - 8/13/2024	REVISED -
PLOT DATE = 8/13/2024		

STATE OF ILLINOIS
DEPARTMENT OF TRANSPORTATION

SCALE: N/A		SHEET 5 OF 8 SHEETS		STA.	TO STA.
------------	--	---------------------	--	------	---------

SUMMARY OF QUANTITIES

F.A.I. RTE.	SECTION	COUNTY	TOTAL SHEETS	SHEET NO.
70	82-5V8-R-2	ST. CLAIR	254	13
			CONTRACT NO. 76K02	
		ILLINOIS	FED. AID PROJECT	

CODE NO.	ITEM	UNIT	TOTAL QUANTITY	CONSTRUCTION CODE	
				90% FEDERAL 10% STATE	
				BRIDGE	
				0013 SN 082-0017	
* 78200011	BARRIER WALL REFLECTORS, TYPE C	EACH	29	29	
78300200	RAISED REFLECTIVE PAVEMENT MARKER REMOVAL	EACH	244	244	
X0321519	CONDUIT SUPPORT SYSTEM	L SUM	1	1	
X0322559	BOLT REPLACEMENT	EACH	307	307	
X7200202	ALTERNATE ROUTE SIGNING	L SUM	1	1	
X0327543	POLYURETHANE SEALANT	FOOT	3002	3002	
58100210	FULL LANE SEALANT WATERPROOFING SYSTEM	SQ YD	19777	19777	
X5012502	CONCRETE REMOVAL (SPECIAL)	CU YD	1030.6	1030.6	
X5030550	PROTECTIVE COAT (SPECIAL)	SQ YD	68	68	
X6370050	CONCRETE BARRIER WALL (SPECIAL)	FOOT	99	99	
X6700410	ENGINEER'S FIELD OFFICE, TYPE A (SPECIAL)	CAL MO	17	17	
X7010216	TRAFFIC CONTROL AND PROTECTION, (SPECIAL)	L SUM	1	1	
X7010239	CHANGEABLE MESSAGE SIGN, SPECIAL	CAL WK	47	47	
X8570002	SMART TRAFFIC MONITORING SYSTEM	CAL WK	47	47	

* SPECIALTY ITEM

REV - MS

MODEL: D:\efk\1111\13052.29 B&O BR Bridge\DCN\Design\Final\Revised\09-16-24\76K02-2ht-500.dgn

	USER NAME = zWaters	DESIGNED - SJF	REVISED	STATE OF ILLINOIS DEPARTMENT OF TRANSPORTATION	SUMMARY OF QUANTITIES			F.A.I. RTE.	SECTION	COUNTY	TOTAL SHEETS	SHEET NO.
	PLOT SCALE = 20.000' / in.	DRAWN - ZJB	REVISIED -					70	82-5VB-R-2	ST. CLAIR	254	14
	PLOT DATE = 8/13/2024	CHECKED - SLD	REVISIED -		SCALE: N/A	SHEET 6 OF 8 SHEETS	STA.	TO STA.	CONTRACT NO. 76K02		ILLINOIS	FED. AID PROJECT
	DATE - 8/13/2024	DATE - 8/13/2024	REVISIED -									

CODE NO.	ITEM	UNIT	TOTAL QUANTITY	CONSTRUCTION CODE	
				90% FEDERAL 10% STATE	
				BRIDGE	
				0013 SN 082-0017	
X8570004	SMART TRAFFIC MONITORING DEVICE	CAL WK	47	47	
Z0001905	STRUCTURAL STEEL REPAIR	POUND	59170	59170	
X5230144	BRIDGE DRAINAGE SYSTEM REPAIR	EACH	1	1	
Z0007101	CONTAINMENT AND DISPOSAL OF LEAD PAINT CLEANING RESIDUES NO. 1	L SUM	1	1	
Z0010501	CLEANING AND PAINTING STEEL BRIDGE NO. 1	L SUM	1	1	
Z0010605	CLEANING DRAINAGE SYSTEM	L SUM	1	1	
Z0012754	STRUCTURAL REPAIR OF CONCRETE (DEPTH EQUAL TO OR LESS THAN 5 INCHES)	SQ FT	8161	8161	
Z0012755	STRUCTURAL REPAIR OF CONCRETE (DEPTH GREATER THAN 5 INCHES)	SQ FT	915	915	
Z0013798	CONSTRUCTION LAYOUT	L SUM	1	1	
Z0016001	DECK SLAB REPAIR (FULL DEPTH, TYPE I)	SQ YD	52	52	
Z0016002	DECK SLAB REPAIR (FULL DEPTH, TYPE II)	SQ YD	52	52	
Z0016200	DECK SLAB REPAIR (PARTIAL)	SQ YD	496	496	
Z0016702	DETOUR SIGNING	L SUM	1	1	
Z0018051	DRAINAGE SCUPPERS TO BE ADJUSTED	EACH	26	26	

REV - MS

MODEL: D:\efk\11
 FILE NAME: Z:\12052.29 B&O BR Bridge\DCN\Design\Final\Revised\09-16-24\76K02-2ht-500.dgn



USER NAME = ZWaters	DESIGNED - SJF	REVISED
DRAWN - ZJB	CHECKED - SLD	REVISED -
PLOT SCALE = 20.000' / in.	DATE - 8/13/2024	REVISED -
PLOT DATE = 8/13/2024		

STATE OF ILLINOIS
DEPARTMENT OF TRANSPORTATION

SUMMARY OF QUANTITIES

SCALE: N/A SHEET 7 OF 8 SHEETS STA. TO STA.

F.A.I. RTE.	SECTION	COUNTY	TOTAL SHEETS	SHEET NO.
70	82-5VB-R-2	ST. CLAIR	254	15
			CONTRACT NO. 76K02	
		ILLINOIS	FED. AID PROJECT	

CODE NO.	ITEM	UNIT	TOTAL QUANTITY	CONSTRUCTION CODE	
				90% FEDERAL 10% STATE	
				BRIDGE	
				0013 SN 082-0017	
Z0018500	DRAINAGE STRUCTURE TO BE CLEANED	EACH	1	1	
Z0048665	RAILROAD PROTECTIVE LIABILITY INSURANCE	L SUM	1	1	
Z0073410	TEMPORARY SUPPORT SYSTEM, LOCATION 1	EACH	1	1	
Z0073420	TEMPORARY SUPPORT SYSTEM, LOCATION 2	EACH	1	1	
Z0073430	TEMPORARY SUPPORT SYSTEM, LOCATION 3	EACH	1	1	
Z0073431	TEMPORARY SUPPORT SYSTEM, LOCATION 4	EACH	1	1	
Z0073432	TEMPORARY SUPPORT SYSTEM, LOCATION 5	EACH	1	1	
Z0073433	TEMPORARY SUPPORT SYSTEM, LOCATION 6	EACH	1	1	
Z0073434	TEMPORARY SUPPORT SYSTEM, LOCATION 7	EACH	1	1	
Z0073435	TEMPORARY SUPPORT SYSTEM, LOCATION 8	EACH	1	1	
∅ Z0076600	TRAINEES	HOUR	3000	3000	
∅ Z0076604	TRAINEES TRAINING PROGRAM GRADUATE	HOUR	3000	3000	

∅ 0042

REV - MS

MODEL: D:\efh\... FILE NAME: Z:\13052-29 B&O BR Bridge\DCN\Design\Final\FB\Sheet09-16-0876K02-INT-500.dgn



USER NAME = zWaters	DESIGNED - SJF	REVISED
DRAWN - ZJB	CHECKED - SLD	REVISED -
PLOT SCALE = 20,000' / in.	DATE - 8/13/2024	REVISED -
PLOT DATE = 8/13/2024		

**STATE OF ILLINOIS
DEPARTMENT OF TRANSPORTATION**

SUMMARY OF QUANTITIES	
SCALE: N/A	SHEET 8 OF 8 SHEETS STA. TO STA.

F.A.I. RTE.	SECTION	COUNTY	TOTAL SHEETS	SHEET NO.
70	82-5V8-R-2	ST. CLAIR	254	16
ILLINOIS FED. AID PROJECT			CONTRACT NO. 76K02	

* EX. GUARDRAIL AND TRAFFIC BARRIER TERMINALS
 STA. 71+20 TO STA. 72+74
 STA. 89+48 TO STA. 92+91

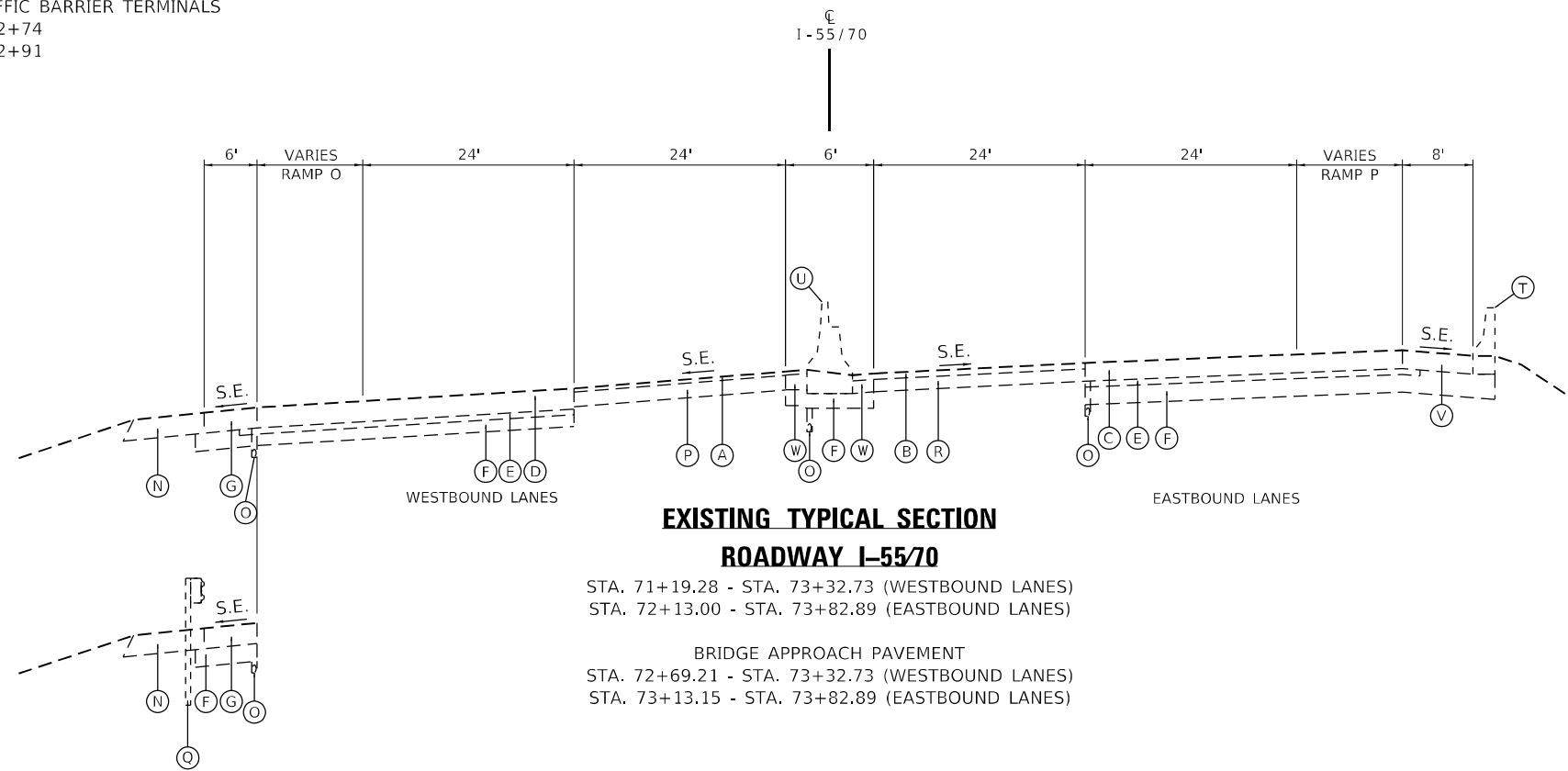

**EXISTING TYPICAL SECTION
 ROADWAY I-55/70**

STA. 71+19.28 - STA. 73+32.73 (WESTBOUND LANES)
 STA. 72+13.00 - STA. 73+82.89 (EASTBOUND LANES)

BRIDGE APPROACH PAVEMENT
 STA. 72+69.21 - STA. 73+32.73 (WESTBOUND LANES)
 STA. 73+13.15 - STA. 73+82.89 (EASTBOUND LANES)

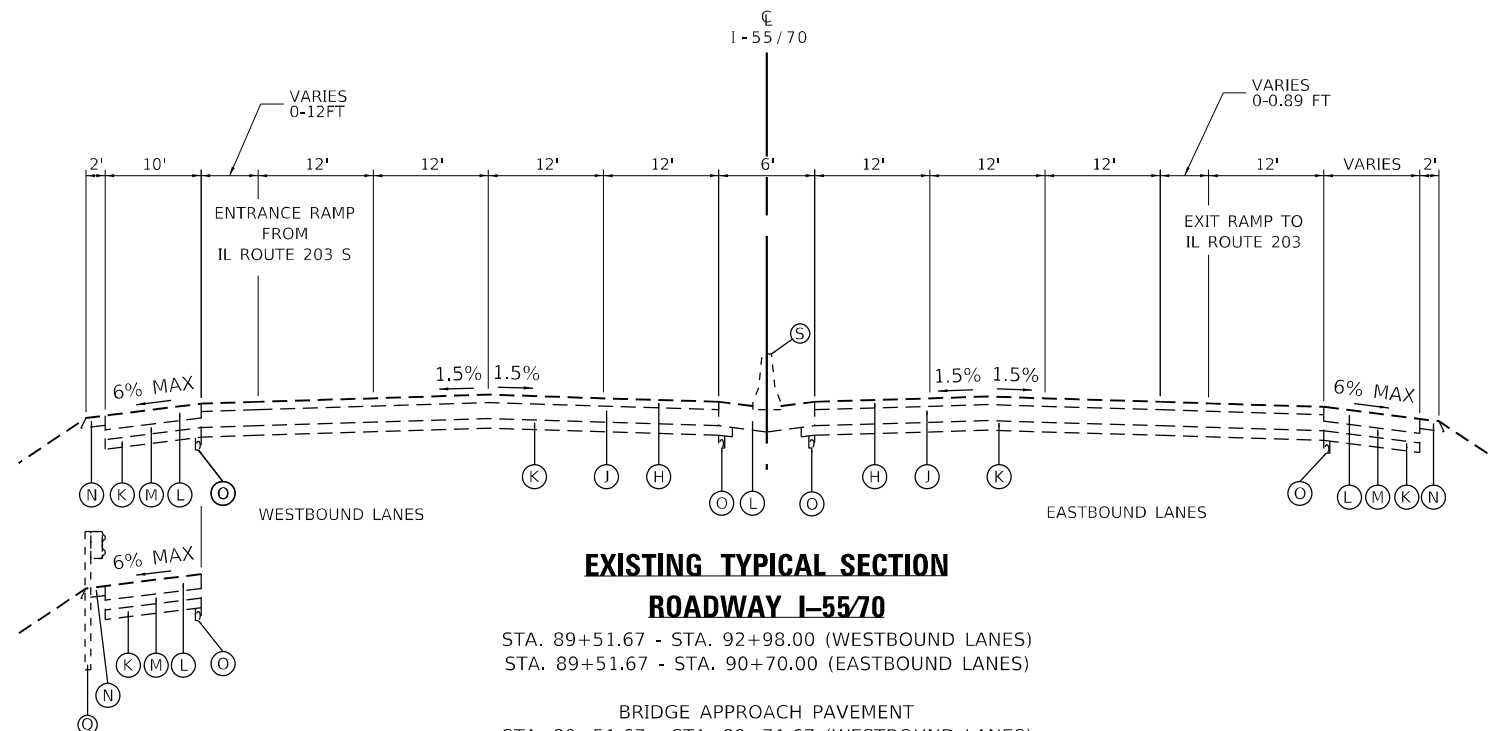

**EXISTING TYPICAL SECTION
 ROADWAY I-55/70**

STA. 89+51.67 - STA. 92+98.00 (WESTBOUND LANES)
 STA. 89+51.67 - STA. 90+70.00 (EASTBOUND LANES)

BRIDGE APPROACH PAVEMENT
 STA. 89+51.67 - STA. 89+71.67 (WESTBOUND LANES)
 STA. 89+51.67 - STA. 89+71.67 (EASTBOUND LANES)

EXISTING

- (A) BITUMINOUS OVERLAY, 2-1/2"
- (B) BITUMINOUS OVERLAY, 4"
- (C) CONTINUOUSLY REINFORCED PCC PAVEMENT, 14"
- (D) CONTINUOUSLY REINFORCED PCC PAVEMENT, 12-1/2"
- (E) STABILIZED SUB-BASE - HOT-MIX ASPHALT, 4"
- (F) AGGREGATE BASE COURSE, TYPE A 12"
- (G) PCC SHOULDER, 12-1/2"
- (H) BITUMINOUS OVERLAY, 5"
- (J) PCC PAVEMENT, 10"
- (K) SUB-BASE GRANULAR MATERIAL, 6"
- (L) BITUMINOUS SHOULDER
- (M) GRAVEL OR CRUSHED STONE SHOULDER
- (N) AGGREGATE SHOULDERS, TYPE B
- (O) PIPE UNDERDRAINS, 6"
- (P) PCC PAVEMENT, 10-1/2"
- (Q) STEEL PLATE BEAM GUARDRAIL TYPE A, 6 FOOT POST
- (R) PCC PAVEMENT, 12"
- (S) CONCRETE BARRIER DOUBLE FACE, 42"
- (T) CONCRETE BARRIER SINGLE FACE, 42"
- (U) CONCRETE BARRIER WITH GLARE SCREEN
- (V) PCC SHOULDER, 14"
- (W) PCC SHOULDER, 10"

MODEL: Default
 FILE NAME: Z:\13052-29_B&O_BR_Bridge\DCN\Design\Final\Final\82-5V8-R-2-ent-typical.dgn

EFK Moen
 Civil Engineering Design

USER NAME = zWaters	DESIGNED - JRD	REVISED
DRAWN - SJF	REVISED -	
PLOT SCALE = 20,0000 * / in.	CHECKED - SLD	REVISED -
PLOT DATE = 8/13/2024	DATE - 8/13/2024	REVISED -

**STATE OF ILLINOIS
 DEPARTMENT OF TRANSPORTATION**

**TYPICAL SECTIONS
 EXISTING**

SCALE: N.T.S. SHEET 1 OF 2 SHEETS STA. TO STA.

F.A.I. RTE.	SECTION	COUNTY	TOTAL SHEETS	SHEET NO.
70	82-5V8-R-2	ST. CLAIR	254	17
CONTRACT NO. 76K02				
ILLINOIS FED. AID PROJECT				

EROSION CONTROL SCHEDULE				
LOCATION				PERIMETER EROSION BARRIER (FOOT)
ROADWAY	STATION	STATION	LT/RT	
I-55S/70W	72+35	72+86	LT	62.7
I-55S/70W	89+50	89+99	LT	61.4
I-55N/70E	89+50	89+84	RT	46.3
BELOW BRIDGE	84+45	84+45	LT/RT	160.0
SUB TOTAL				330.4
TOTALS				331

MISCELLANEOUS ITEMS				
ROADWAY	ENGR FLD OFFICE TYPE A (SPECIAL) (CAL MO)	MOBILIZATION (L SUM)	CONSTRUCTION LAYOUT (L SUM)	RAILROAD PROTECTION LIABILITY INSURANCE (L SUM)
I-55/70	17	1	1	1
TOTALS	17	1	1	1

TRAFFIC CONTROL & PROTECTION SCHEDULE						
LOCATION		CHANGEABLE MESSAGE SIGN (CAL DA)	NIGHTTIME WORK ZONE LIGHTING (L SUM)	ALTERNATE ROUTE SIGNING (L SUM)	TRAFFIC CONTROL & PROTECTION SPECIAL (L SUM)	DETOUR SIGNING (L SUM)
ROADWAY	STATION					
I-55N/64E	WEST OF TRI-LEVEL	238				STAGE 1 - STAGE 5
I-64W	EAST OF I-255 INTERCHANGE	238				STAGE 1 - STAGE 5
I-70E	EAST OF STAN MUSIAL VETERANS BRIDGE	238				STAGE 1 - STAGE 5
I-255S	NORTH OF I-55 INTERCHANGE	238				STAGE 1 - STAGE 5
I-55S/70W	EAST OF I-255 INTERCHANGE	119				STAGE 6 - STAGE 8
I-255S	NORTH OF I-55 INTERCHANGE	119				STAGE 6 - STAGE 8
IL ROUTE 203S	NEAR RACE TRACK	119				STAGE 6 - STAGE 8
IL ROUTE 203N	NEAR COLLINSVILLE RD	119				STAGE 6 - STAGE 8
I-55/70	ENTIRE PROJECT		1	1	1	1
SUBTOTAL		1428	1	1	1	1
TOTALS		1428	1	1	1	1

RIGHT OF WAY SCHEDULE				
LOCATION				FUR ERECT MARKERS (FOOT)
ROADWAY	STATION	OFFSET	LT/RT	
I-55/70	74+65.40	99.94'	LT	1
I-55/70	76+05.66	100.05'	RT	1
I-55/70	76+57.11	100.05'	RT	1
I-55/70	80+46.32	99.98'	LT	1
I-55/70	81+46.96	100.02'	RT	1
TOTALS				5

ENVIRONMENTAL					
LOCATION	NON SPL WASTE DISPOSAL (CU YD)	SOIL DISPOSAL ANALY (EACH)	REG SUB P-CONST PLAN (L SUM)	REG SUB F CON REPORT (L SUM)	REG SUB MON (CAL DA)
I-55/70	238	1	1	1	20
PAY ITEM TOTALS	238	1	1	1	20

SMART TRAFFIC MONITORING				
LOCATION	CMS SPECIAL (CAL WK)	SMART TRAF MONIT SYS (CAL WK)	SMART TRAF MONIT DEVICE (CAL WK)	NOTES
I-55N/70E	32.0	32.0	32.0	STAGE 1 - STAGE 5
I-55S/70W	15.0	15.0	15.0	STAGE 6 - STAGE 8
TOTALS	47	47	47	

MODEL: D:\efk\h...
 FILE NAME: 211305229 B60 BR Bridge\DCN\Design\Final\Final\1925087802-con-schedule.dgn



USER NAME = zWaters	DESIGNED - SJF	REVISED
DRAWN - SJF	CHECKED - SLD	REVISED -
PLOT SCALE = 20,0000 * / in.	DATE - 8/13/2024	REVISED -
PLOT DATE = 8/13/2024		

**STATE OF ILLINOIS
DEPARTMENT OF TRANSPORTATION**

SCHEDULE OF QUANTITIES		
SCALE: N/A	SHEET 1 OF 8 SHEETS	STA. TO STA.

F.A.I. RTE.	SECTION	COUNTY	TOTAL SHEETS	SHEET NO.
70	82-5V8-R-2	ST. CLAIR	254	19
CONTRACT NO. 76K02				
ILLINOIS FED. AID PROJECT				

GUARDRAIL SCHEDULE											
LOCATION				SPBGR TY A 6 FT POSTS (FOOT)	TRAF BAR TERM T2 (EACH)	TRAF BAR TERM T5 (EACH)	TRAF BAR TERM T6 (EACH)	TRAF BAR TERM T1 SPL TAN (EACH)	GUARDRAIL REMOVAL (FOOT)	TERMINAL MARKER DIRECT APPLIED (EACH)	GUARDRAIL REFL TY A (EACH)
ROADWAY	STATION	STATION	LT/RT								
I-55S/70W	71+32.26	72+61.43	LT	125							
I-55S/70W	89+98.05	92+48.01	LT	250							
I-55S/70W	71+19.28	71+32.26	LT		1						
I-55S/70W	72+61.43	72+74.85	LT			1					
I-55S/70W	89+61.17	89+98.05	LT				1				
I-55S/70W	92+48.01	92+98.00	LT					1			
I-55S/70W	71+20	72+74	LT						149.9		
I-55S/70W	89+48	92+91	LT						342.9		
I-55S/70W	92+98		LT							1	
I-55S/70W	71+19.28	72+74.85	LT								2
I-55S/70W	89+61.17	92+98.00	LT								4
SUBTOTALS				375	1	1	1	1	492.8	1	6
PAY ITEM TOTALS				375	1	1	1	1	493	1	6

TEMPORARY AND PERMANENT CONCRETE BARRIER SCHEDULE											
LOCATION					TEMP CONC BARRIER (FOOT)	REL TEMP CONC BARRIER (FOOT)	IMP ATTN TEMP NRN TL3 (EACH)	IMP ATTN REL NRN TL3 (EACH)	BARR WALL REFL TY C (EACH)	CONCRETE BARR WALL (SPECIAL) (FOOT)	NOTES
ROADWAY	STATION	OFFSET	ROADWAY	OFFSET	STATION						
I-55/70	89+71.67		90+70.00		CL				98.3		
RAMP 70E55N	*AT GORE		*225' TO GORE			225		1			STAGES 1 & 2
RAMP 64W55N	*AT OVERHEAD SIGN TRUSS					750		1			STAGES 1 & 2
I55N/70E	69+87	10.94' RT	80+32	32.0' RT	RT	1050		1			STAGE 1
RAMP 70E55N	*AT GORE		*225' TO GORE			225		1			STAGES 3 & 4
RAMP 64W55N	*AT OVERHEAD SIGN TRUSS					750		1			STAGES 3 & 4
I55N/70E	69+87	10.94' RT	90+82	31.63' RT	RT	2100		1			STAGE 3
I55N/70E	88+47	25.06' RT	90+85	25.06' RT	RT						STAGE 4A
I55S/70W	71+50	31.6' LT	93+52	7.26' LT	LT	2200		1			STAGE 6
I55N/70E	75+05	53.12' RT	80+48	25.06' RT	RT		1050		1		STAGE 2
I55N/70E	75+05	53.12' RT	88+47	25.06' RT	RT		1850		1		STAGE 4
I55S/70W	71+55	27.56' LT	93+55	47.94' LT	LT		2200		1		STAGE 7
I-55S/70W	72+69.24		78+69		LT				3		200' SPACING
I-55S/70W	78+69		89+63		LT				3		400' SPACING
I-55S/70W	71+67		72+69.24		CNTR LT				1		125' SPACING
I-55S/70W	72+69.24		78+69		CNTR LT				3		200' SPACING
I-55S/70W	78+69		90+70		CNTR LT				4		400' SPACING
I-55N/70E	72+13		72+69.24		CNTR RT				1		125' SPACING
I-55N/70E	72+69		78+69		CNTR RT				3		200' SPACING
I-55N/70E	78+69		90+70		CNTR RT				4		400' SPACING
I-55N/70E	72+13		72+69.24		RT				1		125' SPACING
I-55N/70E	72+69.24		78+69		RT				3		200' SPACING
I-55N/70E	78+69		89+63		RT				3		400' SPACING
SUBTOTALS						7537.5	5100	7	3	29	98.3
TOTALS						7537.5	5100	7	3	29	99

MODEL: D:\efk\B60_BR_Bridge\DCN\Design\Final\B60-20-24-Schedule.dgn
 FILE NAME: 2410052-29_B60_BR_Bridge\DCN\Design\Final\B60-20-24-Schedule.dgn



USER NAME = zWaters	DESIGNED - SJF	REVISED
PLOT SCALE = 20,0000 * / in.	DRAWN - SJF	REVISED -
PLOT DATE = 8/13/2024	CHECKED - SLD	REVISED -
	DATE - 8/13/2024	REVISED -

STATE OF ILLINOIS
DEPARTMENT OF TRANSPORTATION

SCALE: N/A		SHEET 2 OF 8 SHEETS		STA.	TO STA.
------------	--	---------------------	--	------	---------

F.A.I. RTE.	SECTION	COUNTY	TOTAL SHEETS	SHEET NO.
70	82-5V8-R-2	ST. CLAIR	254	20
CONTRACT NO. 76K02				
ILLINOIS FED. AID PROJECT				

DRAINAGE STRUCTURE SCHEDULE															
LOCATION						TRENCH BACKFILL (CU YD)	STONE RIPRAP CL A3 (SQ YD)	END SECTIONS 12" (EACH)	STORM SEWERS CL A TY 2, 12" (FOOT)	INLETS TO BE ADJUSTED (EACH)	REMOVING INLETS (EACH)	CONCRETE THRUST BLOCKS (EACH)	TYPE E INLET BOX STANDARD 610001 (EACH)	CONCRETE SHLDR CURB (FOOT)	DRAINAGE STR TO BE CLEANED (EACH)
ROADWAY	LOCATION	OFFSET	LOCATION	OFFSET	LT/RT										
I-55S/70W	72+45.5	59.1' LT	72+45.49	101.2' LT	LT	0.5	2.0	1	40.0			1	1		
I-55S/70W	89+87	56.8' LT	89+87	108.7' LT	LT	0.5	2.0	1	50.0			1	1		
I-55N/70E	89+72	56.9' RT	89+72	102.6' RT	RT	0.5	2.0	1	44.0			1	1		
I-55N/70E	73+69	55' RT								1				1	
I-55S/70W	72+72.03	55.1' LT								1					
I-55S/70W	89+66.52	54.9' LT								1					
I-55N/70E	89+66.36	55.0' RT								1					
I-55S/70W	72+40.49	60.6' LT	72+74.85	56.6' LT										33.6	
I-55S/70W	89+62.98	57.3' LT	89+93.91	57.5' LT										30.9	
I-55N/70E	89+63.28	56.8' RT	89+77.34	57.9' RT										14.1	
SUBTOTALS						1.5	6.0	3.0	134.0	1	3	3	3	78.6	
TOTALS						2	6	3	134	1	3	3	3	79	1

PAVEMENT AND SHOULDER REMOVAL SCHEDULE							
LOCATION				HMA SURF REMOVAL BUTT JT (SQ YD)	HMA SURF REMOVAL 3/4" (SQ YD)	PAVED SHLDR REMOV (SQ YD)	
ROADWAY	STATION	STATION	RT/LT				
I-55S/70W	71+67.00	72+34.00	LT	448.0			
I-55S/70W	89+70.00	90+70.00	LT	611.5			
I-55N/70E	72+13.00	72+80.00	RT	454.8			
I-55N/70E	89+70.00	90+70.00	RT	640.7			
I-55S/70W	72+34.00	73+32.73	LT		436.9		
I-55S/70W	89+51.67	89+70.00	LT		108.0		
I-55N/70E	72+80.00	73+82.89	RT		516.7		
I-55N/70E	89+51.67	89+70.00	RT		108.8		
I-55N/70E	89+68	93+60	RT			361.9	PRE STAGE
I-55S/70W	98+08	102+90	LT			558.5	PRE STAGE
I-55S/70W	72+39.82	72+74.67	LT			19.6	STAGE 2
I-55S/70W	89+62.98	89+93.91	LT			23.5	STAGE 2
I-55N/70E	89+63.28	89+77.35	RT			8.7	STAGE 2
SUBTOTALS				2155.1	1170.4	972.2	
TOTALS				2156	1171	973	

MODEL: D:\efk\h
 FILE NAME: 2413052.29 B&O BR Bridge\DCN\Design\Final\FinalSheet119-25-0878K02-ent-Schedule.dgn



USER NAME = zWaters	DESIGNED - SJF	REVISED
DRAWN - SJF	REVISIONS -	
PLOT SCALE = 20,0000 * / in.	CHECKED - SLD	REVISED -
PLOT DATE = 8/13/2024	DATE - 8/13/2024	REVISED -

STATE OF ILLINOIS
DEPARTMENT OF TRANSPORTATION

SCHEDULE OF QUANTITIES

SCALE: N/A SHEET 3 OF 8 SHEETS STA. TO STA.

F.A.I. RTE.	SECTION	COUNTY	TOTAL SHEETS	SHEET NO.
70	82-5V8-R-2	ST. CLAIR	254	21
CONTRACT NO. 76K02				
ILLINOIS FED. AID PROJECT				

PAVEMENT AND SHOULDER SCHEDULE

LOCATION					GEOTECH FAB FOR GRND STAB (SQ YD)	AGG BASE COURSE TY A, 12" (SQ YD)	POLY BIT MATRLS TACK COAT (POUND)	POLY HMA SC SMA 9.5 MIX "E" N80 (TON)	AGG WEDGE SHLDR TY B (TON)	HMA SHOULDER 10" (SQ YD)	PCC SHOULDER 12 3/4" (SQ YD)	LONGITUDINAL JOINT SEALANT (FOOT)	SHLD RUMBLE STRIPS 16" (FOOT)	NOTES
ROADWAY	STATION	OFFSET	STATION	OFFSET										
I-55/70	BOWMAN YARD ACCESS ROAD				588	588								
I-55S/70W	71+67.00	-	72+67.00	-			398.0	80.0						PMT TRANSITION
I-55S/70W	72+67.00	-	73+32.73	-				41.6						BRIDGE APPROACH
I-55S/70W	89+51.67	-	89+70.00	-			325.0	18.1						BRIDGE APPROACH
I-55S/70W	89+70.00	-	90+70.00	-				103.1						PMT TRANSITION
I-55N/70E	72+13.00	-	73+13.00	-			438.0	84.9						PMT TRANSITION
I-55N/70E	73+13.00	-	73+34.98	-				50.1						BRIDGE APPROACH
I-55N/70E	89+51.67	-	89+70.00	-			339.0	18.3						BRIDGE APPROACH
I-55N/70E	89+70.00	-	90+70.00	-				108.0						PMT TRANSITION
I-55/70	B&O BRIDGE DECK													BRIDGE DECK
I-55S/70W	71+67.00		72+40.49						2.0					
I-55S/70W	89+93.91		90+70.00						2.1					
I-55N/70E	89+77.30		90+70.00						2.5					
I-55N/70E	89+68	51.5' RT	93+60	83.7' RT						345.2				PRE STAGE
I-55S/70W	98+08	40.3' LT	102+90	56' LT						540.3				PRE STAGE
I-55N/70E	89+63.28	51.5' RT	89+77.40	51.6' RT						9.9				STAGE 4A
I-55S/70W	72+50.13	54.2' LT	72+74.67	52.4' LT						14.1				STAGE 7
I-55S/70W	89+62.98	50.8' LT	89+82.04	50.8' LT						15.0				STAGE 7
I-55S/70W	71+67	52.4' LT	72+89.32	51.2' LT							119.3			
I-55S/70W	71+67	40.4' LT	72+99.84	39.1' LT							130.5			
I-55S/70W	71+67	28.4' LT	73+10.36	27.0' LT							141.8			
I-55S/70W	71+67	16.4' LT	73+20.89	14.9' LT							153.0			
I-55S/70W	89+51.67	39.0' LT	90+70	39.0' LT							118.3			
I-55S/70W	89+51.67	27.0' LT	90+70	27.0' LT							118.3			
I-55S/70W	89+51.67	15.0' LT	90+70	15.0' LT							118.3			
I-55N/70E	72+13	15.2' RT	73+46.89	15.0' RT							134.4			
I-55N/70E	72+13	27.2' RT	73+57.32	27.0' RT							145.2			
I-55N/70E	72+13	39.2' RT	73+67.75	39.0' RT							156.0			
I-55N/70E	72+13	51.2' RT	73+12.82	51.0' RT							101.4			
I-55N/70E	89+51.67	15.0' RT	90+70	15.0' RT							118.3			
I-55N/70E	89+51.67	27.0' RT	90+70	27.0' RT							118.3			
I-55N/70E	89+51.67	39.0' RT	90+70	40.1' RT							118.3			
I-55S/70W	99+07.00	43.2' LT	102+90	47.6' LT								383		
SUBTOTALS					588.0	588.0	1500.0	504.1	6.6	885.5	39.0	1791.4	383.0	
TOTALS					588	588	1500	505	7	886	39	1792	383	

MODEL: D:\efk\...
 FILE NAME: 211305229 B&O BR Bridge\DC\N\Design\Final\Final\Sheet119-25-0876K02-ent-Schedule.dgn



USER NAME = zWaters	DESIGNED - SJF	REVISED
DRAWN - SJF	REVISIONS -	
PLOT SCALE = 20,0000 * / in.	CHECKED - SLD	REVISED -
PLOT DATE = 8/13/2024	DATE - 8/13/2024	REVISED -

STATE OF ILLINOIS
DEPARTMENT OF TRANSPORTATION

SCHEDULE OF QUANTITIES	
SCALE: N/A	SHEET 4 OF 8 SHEETS STA. TO STA.

F.A.I. RTE.	SECTION	COUNTY	TOTAL SHEETS	SHEET NO.
70	82-5V8-R-2	ST. CLAIR	254	22
CONTRACT NO. 76K02				
ILLINOIS FED. AID PROJECT				

TEMPORARY PAVEMENT MARKING SCHEDULE (2 OF 3)

LOCATION								PAVEMENT MARKING BLACKOUT TAPE 5" (FOOT)	PAVEMENT MARKING BLACKOUT TAPE 7" (FOOT)	PAVEMENT MARKING BLACKOUT TAPE 9" (FOOT)	SHORT TERM PAVEMENT MARKING (FOOT)	TEMPORARY PAVEMENT MARKING LINE 6" T4 TAPE (FOOT)	SHORT TERM PAVEMENT MARKING REMOVAL (SQ FT)	NOTES
ROADWAY	STATION	OFFSET	TO	ROADWAY	OFFSET	STATION	STAGE							
I-55N/70E	70+21.85	39.4' RT		I-55N/70E	84+56.78	38.9' RT	STAGE 1			360		270	9' SKIP-3' DASH	
*I-70E	GORE END			*I-70E	172' SE OF BRIDGE OVER 1ST ST			STAGE 1		117		87.75	9' SKIP-3' DASH	
*I-64W	525' TO GORE BEGIN			*I-64W	620' TO GORE BEGIN			STAGE 1		24		18	9' SKIP-3' DASH	
RAMP 70E55N	67+16.50	46.2' RT		RAMP 70E55N	69+93.93	29.7' RT	STAGE 3			284		213	GORE LINE	
I-55N	66+17.88	41.5' RT		I-55N	69+19.25	29.7' RT	STAGE 3		164	308		326.6666667	GORE LINE AND CHEVRONS	
I-55N/70E	92+52.19	38.6' RT		I-55N/70E	94+90.94	38.3' RT	STAGE 3		54	239		210.75	GORE LINE AND CHEVRONS	
I-55N/70E	92+52.19	38.6' RT		I-55N/70E	93+53.13	49.0' RT	STAGE 3			101		75.75	GORE LINE	
*PACKER AVE ENT RAMP	49' TO GORE			*PACKER AVE ENT RAMP	END GORE			STAGE 3				967	GORE LINE	
*I-70E	718' TO GORE END			*I-70E	END GORE			STAGE 3				719	GORE LINE	
*I-70E	172' S OF BRIDGE OVER 1ST ST			*I-70E	BEGIN GORE			STAGE 3				278	LANE LINE	
*I-70E	BEGIN GORE			*I-70E	341' FROM GORE BEGIN			STAGE 3				341	GORE LINE	
*RAMP 70E64E	BEGIN GORE			*RAMP 70E64E	BEGIN OF PARAPET WALL			STAGE 3		296		788	763.6666667 GORE LINE AND CHEVRONS	
*I-64W AT RAMP 64W55N	BEGIN GORE			*I-64W	525' TO GORE BEGIN			STAGE 3				525	393.75 LANE LINE	
I-55N	63+22.54	39.9' RT		I-55N	66+92.56	35.3' RT	STAGE 3			93		69.75	9' SKIP-3' DASH	
RAMP 70E55N	69+17.41	53.7' RT		I-55N/70E	72+87.94	51.0' RT	STAGE 3			96		72	9' SKIP-3' DASH	
I-55N/70E	70+21.85	39.4' RT		I-55N/70E	91+09.99	41.2' RT	STAGE 3			525		393.75	9' SKIP-3' DASH	
*I-70E	GORE END			*I-70E	172' SE OF BRIDGE OVER 1ST ST			STAGE 3				117	9' SKIP-3' DASH	
*I-64W	525' TO GORE BEGIN			*I-64W	620' TO GORE BEGIN			STAGE 3				24	18 9' SKIP-3' DASH	
I-55S	66+18.30	29.5' LT		I-55S	68+73.03	30.87' LT	STAGE 6		218	251		315.4166667	GORE LINE AND CHEVRONS	
RAMP 55S70W	67+46.73	44.0' LT		RAMP 55S70W	69+61.06	34.78' LT	STAGE 6			210		157.5	GORE LINE	
RAMP 55S70W	67+15.38	68.4' LT		I-55S/70W	69+94.98	56.9' LT	STAGE 6		28	270		218.8333333	GORE LINE AND CHEVRONS	
RAMP TO EXCHANGE	68+29.16	66.5' LT		RAMP TO EXCHANGE	69+21.36	59.5' LT	STAGE 6			89		66.75	GORE LINE	
I-55S/70W	69+94.98	56.9' LT		I-55S/70W	72+67.85	50.7' LT	STAGE 6			66		49.5	9' SKIP-3' DASH	
I-55S/70W	97+58.01	39.9' LT		I-55S/70W	98+07.71	40.3' LT	STAGE 6			50		37.5	GORE LINE	
RAMP 203S55S	97+58.01	39.9' LT		RAMP 203S55S	98+13.55	47.6' LT	STAGE 6			56		42	GORE LINE	
*IL 203N	EX JOINT OF BRIDGE OVER I55/70			*IL 203N	31' N OF BRIDGE OVER I55/70			STAGE 6				78	58.5 9' SKIP-3' DASH	
I-55S	68+87.79	30.7' LT		I-55S	70+98.84	28.4' LT	STAGE 7			196		147	GORE LINE	
RAMP 55S70W	69+61.06	34.8' LT		RAMP 55S70W	70+98.84	28.4' LT	STAGE 7			135		101.25	GORE LINE	
I-55S/70W	70+98.84	28.4' LT		I-55S/70W	71+40.61	28.6' LT	STAGE 7			41		30.75	LANE LINE	
I-55N/70E	72+13.00	51.17' RT			73+12.82	51' RT					12	4	SKIP-DASH LANE LINES	
I-55N/70E	72+13.00	39.16' RT			90+70.00	40.12' RT					184	61.33333333	SKIP-DASH LANE LINES	
I-55N/70E	72+13.00	27.16' RT			90+70.00	27' RT					184	61.33333333	SKIP-DASH LANE LINES	
I-55N/70E	72+12.71	15.16' RT			90+70.00	15' RT					184	61.33333333	SKIP-DASH LANE LINES	
I-55N/70E	72+13.00	53.35' RT			90+70.00	52.13' RT					134.3	44.76666667	EDGE LINE (45° ANGLE)	
I-55S/70W	71+67.00	16.36' LT			90+70.00	15' LT					192	64	SKIP-DASH LANE LINES	
I-55S/70W	71+67.00	28.36' LT			74+97.00	27' LT					64	21.33333333	DOUBLE WHITE	
I-55S/70W	74+97.00	27' LT			90+70.00	27' LT					156	52	SKIP-DASH LANE LINES	
I-55S/70W	71+67.00	40.36' LT			90+70.00	39' LT					192	64	SKIP-DASH LANE LINES	
I-55S/70W	71+67.00	52.36' LT			72+91.11	51.22' LT					8	2.666666667	SKIP-DASH LANE LINES	
I-55S/70W	71+67.00	60.73' LT			90+70.00	51' LT					134.333535	44.777845	EDGE LINE (45° ANGLE)	
*I-55N	245' FROM END OF RAMP 64W55N GORE			I55N/70E	84+57	51.0' RT	STAGE 1					2220	1110	SOLID WHITE EDGE LINE
I-55N	64+32.34	20.7' RT		I55N/70E	86+22	3.1' RT	STAGE 1					2205	1102.5	SOLID YELLOW EDGE LINE
I-55N	64+32.38	32.7' RT		I55N/70E	72+71	45.2' RT	STAGE 1					856	428	SOLID WHITE LANE LINE
I55N/70E	72+71.00	45.2' RT		I55N/70E	84+57	38.9' RT	STAGE 1					300	150	WHITE 30'-10' SKIP DASH
*I-55N	245' FROM END OF RAMP 64W55N GORE			I55N/70E	67+50	33.6' RT	STAGE 2					497	248.5	SOLID WHITE EDGE LINE
I55N/70E	69+00	5.8' RT		I55N/70E	83+44	3.0' RT	STAGE 2					1445	722.5	SOLID YELLOW EDGE LINE
I55N/70E	69+00	16.5' RT		I55N/70E	73+35	12.7' RT	STAGE 2					438	219	SOLID WHITE LANE LINE
I55N/70E	69+00	29.6' RT		I55N/70E	84+45	51.0' RT	STAGE 2					1553	776.5	SOLID WHITE EDGE LINE
I55N/70E	73+35	12.7' RT		I55N/70E	83+44	15.3' RT	STAGE 2					250	125	WHITE 30'-10' SKIP DASH
*I-55N	END OF RAMP 64W55N GORE			*I-55N	245' FROM END OF RAMP 64W55N GORE			STAGES 1 & 2				245	122.5	SOLID WHITE EDGE LINE
*I-70E	155' TO PACKER AVE ENT GORE END			*RAMP 70E64E	240' TO GORE END WITH I-64E			STAGES 1 & 2				3549	1774.5	SOLID YELLOW EDGE LINE
SCHEDULE 2 SUBTOTALS								0.0	760.0	7348.0	1444.6	13558.0	13214.9	

*Location is not stationed

MODEL: D:\efk\... FILE NAME: 2119052-29 B&O BR Bridge\DCN\Design\Final\B&O-2119052-29-5ch-schedule.dgn



USER NAME = zWaters	DESIGNED - SJF	REVISED
DRAWN - SJF	REVISIONS -	
PLOT SCALE = 20,0000 * / in.	CHECKED - SLD	REVISED -
PLOT DATE = 8/13/2024	DATE - 8/13/2024	REVISED -

STATE OF ILLINOIS
DEPARTMENT OF TRANSPORTATION

SCHEDULE OF QUANTITIES

SCALE: N/A SHEET 6 OF 8 SHEETS STA. TO STA.

F.A.I. RTE.	SECTION	COUNTY	TOTAL SHEETS	SHEET NO.
70	82-5V8-R-2	ST. CLAIR	254	24
CONTRACT NO. 76K02				
ILLINOIS FED. AID PROJECT				

TEMPORARY PAVEMENT MARKING SCHEDULE (3 OF 3)

LOCATION								PAVEMENT MARKING BLACKOUT TAPE 5" (FOOT)	PAVEMENT MARKING BLACKOUT TAPE 7" (FOOT)	PAVEMENT MARKING BLACKOUT TAPE 9" (FOOT)	SHORT TERM PAVEMENT MARKING (FOOT)	TEMPORARY PAVEMENT MARKING LINE 6" T4 TAPE (FOOT)	SHORT TERM PAVEMENT MARKING REMOVAL (SQ FT)	NOTES
ROADWAY	STATION	OFFSET	TO	ROADWAY	OFFSET	STATION	STAGE							
*I-70E	155' TO PACKER AVE ENT GORE END			*RAMP 70E64E	1240' TO GORE END WITH I-64E		STAGES 1 & 2					640	320	WHITE 30'-10' SKIP DASH
*I-70E	155' TO PACKER AVE ENT GORE END			*I-70E	600' TO PACKER AVE \START ENT GORE		STAGES 1 & 2					446	223	SOLID WHITE GORE
*PACKER AVE ENT RAMP	49' TO PACKER AVE START ENT GORE			*PACKER AVE ENT RAMP	600' TO PACKER AVE START ENT GORE		STAGES 1 & 2					649	324.5	SOLID WHITE GORE
*PACKER AVE ENT RAMP	49' TO PACKER AVE START ENT GORE			*RAMP 70E64E	240' TO GORE END WITH I-64E		STAGES 1 & 2					3760	1880	SOLID WHITE EDGE LINE
*I-64W	580' FROM PEDESTRIAN BRIDGE			*I-64W	61' TO OVERHEAD SIGN TRUSS		STAGES 1 & 2					600	300	SOLID WHITE EDGE LINE
*I-55N	245' FROM END OF RAMP 64W55N GORE			RAMP 55N203	94+85	94.5' RT	STAGE 3					3251	1625.5	SOLID WHITE EDGE LINE
I-55N	64+32	20.7' RT		I55N/70E	98+93	8.0' RT	STAGE 3					3473	1736.5	SOLID YELLOW EDGE LINE
I-55N	64+32	32.7' RT		I55N/70E	72+71	45.2' RT	STAGE 3					856	428	SOLID WHITE LANE LINE
I55N/70E	72+71	45.2' RT		I55N/70E	97+93	30.6' RT	STAGE 3					630	315	WHITE 30'-10' SKIP DASH
I55N/70E	92+57	50.1' RT		I55/70	97+93	42.6' RT	STAGE 3					535	267.5	SOLID WHITE GORE
RAMP 55N203	92+57	50.1' RT		RAMP 55N203	95+87	91.7' RT	STAGE 3					333	166.5	SOLID WHITE GORE
I55N/70E	90+93	56' RT		I55N/70E	92+57	50.1' RT	STAGE 3					42	21	WHITE 9'-3' SKIP DASH
*I-55N	245' FROM END OF RAMP 64W55N GORE			I55N/70E	67+50	33.6' RT	STAGE 4					497	248.5	SOLID WHITE EDGE LINE
I55N/70E	69+00	5.8' RT		I55N/70E	91+36	3.0' RT	STAGE 4					2237	1118.5	SOLID YELLOW EDGE LINE
I55N/70E	69+00	16.5' RT		I55N/70E	73+35	12.7' RT	STAGE 4					438	219	SOLID WHITE LANE LINE
I55N/70E	73+35	12.7' RT		I55N/70E	93+50	14.7' RT	STAGE 4					500	250	WHITE 30'-10' SKIP DASH
I55N/70E	69+00	29.6' RT		RAMP 55N203	93+36	71.9' RT	STAGE 4					2446	1223	SOLID WHITE EDGE LINE
I55N/70E	91+07	23.3' RT		I55N/70E	95+91	39.5' RT	STAGE 4					484	242	SOLID WHITE GORE
RAMP 55N203	91+07	23.3' RT		RAMP 55N203	93+05	43.7' RT	STAGE 4					199	99.5	SOLID WHITE GORE
*I-55N	END OF RAMP 64W55N GORE			*I-55N	245' FROM END OF RAMP 64W55N GORE		STAGES 3 & 4					245	122.5	SOLID WHITE EDGE LINE
*I-70E	155' TO PACKER AVE ENT GORE END			*RAMP 70E64E	240' TO GORE END WITH I-64E		STAGES 3 & 4					3549	1774.5	SOLID YELLOW EDGE LINE
*I-70E	155' TO PACKER AVE ENT GORE END			*RAMP 70E64E	1240' TO GORE END WITH I-64E		STAGES 3 & 4					640	320	WHITE 30'-10' SKIP DASH
*I-70E	155' TO PACKER AVE ENT GORE END			*I-70E	600' TO PACKER AVE START ENT GORE		STAGES 3 & 4					446	223	SOLID WHITE GORE
*PACKER AVE ENT RAMP	49' TO PACKER AVE START ENT GORE			*PACKER AVE ENT RAMP	600' TO PACKER AVE START ENT GORE		STAGES 3 & 4					649	324.5	SOLID WHITE GORE
*PACKER AVE ENT RAMP	49' TO PACKER AVE START ENT GORE			*RAMP 70E64E	240' TO GORE END WITH I-64E		STAGES 3 & 4					3760	1880	SOLID WHITE EDGE LINE
*I-64W	580' FROM PEDESTRIAN BRIDGE			*I-64W	61' TO OVERHEAD SIGN TRUSS		STAGES 3 & 4					600	300	SOLID WHITE EDGE LINE
I55N/70E	88+57	23.1' RT		I55N/70E	91+07	23.3' RT	STAGE 4A					250	125	SOLID WHITE EDGE LINE
RAMP 55S70W	66+60	71.6' LT		I-55/70W	103+00	46.0' LT	STAGE 6					3625	1812.5	SOLID WHITE EDGE LINE
RAMP 55S70W	63+03	75.9' LT		RAMP 55S70W	65+68	61.3' LT	STAGE 6					263	131.5	SOLID YELLOW EDGE LINE
RAMP 55S70W	65+68	61.3' LT		RAMP 55S70W	68+39	49.2' LT	STAGE 6					263	131.5	SOLID WHITE GORE
I-55S	64+42	28.2' LT		I-55S	68+39	49.2' LT	STAGE 6					391	195.5	SOLID WHITE GORE
I-55S	68+39	49.2' LT		I-55S	70+52	58.8' LT	STAGE 6					51	25.5	WHITE 9'-3' SKIP DASH
I-55S	64+32	16.2' LT		I-55/70W	103+00	34.9' LT	STAGE 6					970	485	WHITE 30'-10' SKIP DASH
I-55S	64+32	3.8' LT		I-55/70W	170+74	15.9' LT	STAGE 6					7924	3962	SOLID YELLOW EDGE LINE
I-55/70W	116+17	71.8' LT		I-55/70W	117+17	54.1' LT	STAGE 6					102	51	SOLID WHITE EDGE LINE
RAMP 55S70W	66+20	74.1' LT		I-55/70W	114+47	42.6' LT	STAGE 7					4821	2410.5	SOLID WHITE EDGE LINE
RAMP 55S70W	65+15	57.6' LT		RAMP 55S70W	69+00	29.9' LT	STAGE 7					376	188	SOLID WHITE GORE
I-55/70W	69+00	29.9' LT		I-55/70W	71+50	25.7' LT	STAGE 7					63	31.5	WHITE 9'-3' SKIP DASH
I-55S	66+19	29.6' LT		I-55S	69+00	29.9' LT	STAGE 7					277	138.5	SOLID WHITE GORE
I-55S	66+19	17.6' LT		I-55/70W	93+50	15.4' LT	STAGE 7					680	340	WHITE 30'-10' SKIP DASH
I-55/70W	69+00	5.9' LT		I-55/70W	91+84	3.7' LT	STAGE 7					2283	1141.5	SOLID YELLOW EDGE LINE
RAMP 55S203S	113+00	54.26' LT		RAMP 55S203S	114+47	42.6' LT	STAGE 7					148	74	SOLID WHITE GORE (55S/203S)
RAMP 55S203S	114+47	69.2' LT		I-55/70W	130+88	41.7' LT	STAGE 7					1642	821	SOLID WHITE EDGE LINE
RAMP 55S203N	128+29	78.2' LT		RAMP 55S203N	130+88	41.7' LT	STAGE 7					261	130.5	SOLID WHITE GORE (55S/203N)
RAMP 55S203N	128+32	94.0' LT		I-55/70W	174+68	53.8' LT	STAGE 7					1919	959.5	SOLID WHITE EDGE LINE
*IL 203N	52' FROM END OF RAMP 203N55N GORE			*IL 203N	130' TO RAMP 203N55S GORE		STAGES 6 & 7					501	250.5	SOLID WHITE EDGE LINE
*IL 203S	847' TO OVERHEAD SIGN TRUSS			*IL 203S	104' FROM OVERHEAD SIGN TRUSS		STAGES 6 & 7					954	477	SOLID WHITE EDGE LINE
SCHEDULE 3 SUBTOTALS								0.0	0.0	0.0	0.0	59669.0	29834.5	
SCHEDULES 1, 2, & 3 SUBTOTALS								19301.0	1220.0	11747.0	1444.6	73227.0	54659.0	
TOTALS								19301	1220	11747	1445	73227	54660	

*Location is not stationed

MODEL: D:\efc\1\20190229_B60_BR_Bridge\DCN\Design\Final\Sheet119-25-087800-ent-Schedule.dgn



USER NAME = zWaters	DESIGNED - SJF	REVISED
DRAWN - SJF	REVISIONS -	
PLOT SCALE = 20,0000 * / in.	CHECKED - SLD	REVISED -
PLOT DATE = 8/13/2024	DATE - 8/13/2024	REVISED -

STATE OF ILLINOIS
DEPARTMENT OF TRANSPORTATION

SCHEDULE OF QUANTITIES

SCALE: N/A SHEET 7 OF 8 SHEETS STA. TO STA.

F.A.I. RTE.	SECTION	COUNTY	TOTAL SHEETS	SHEET NO.
70	82-5V8-R-2	ST. CLAIR	254	25
CONTRACT NO. 76K02				
ILLINOIS FED. AID PROJECT				

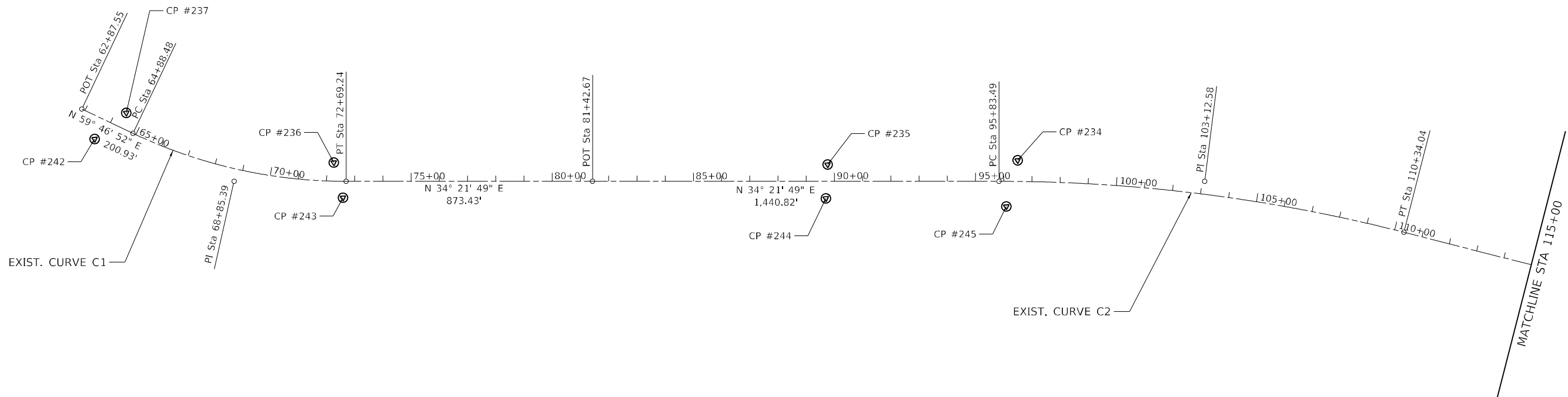

COORDINATE TABLE			
POINT NUMBER	NORTHING	EASTING	DESCRIPTION
CONTROL POINTS			
234	160,955.7663	43,330.6946	IRON PIN W/ PLASTIC CAP
235	160,391.3793	42,962.8326	IRON PIN W/ ALUM CAP
236	158,950.2169	41,968.9435	IRON PIN W/ PLASTIC CAP
237	158,442.5993	41,408.2571	IRON PIN W/ PLASTIC CAP
242	158,297.6966	41,421.5475	IRON PIN W/ PLASTIC CAP
243	158,906.9382	42,090.4449	CUT "X" IN CONCRETE SHOULDER
244	160,318.3959	43,058.5586	IRON PIN W/ PLASTIC CAP
245	160,830.3583	43,443.1823	IRON PIN W/ PLASTIC CAP

COORDINATE TABLE			
STATION	OFFSET	NORTHING	EASTING
I-55/70			
POT 62+87.55	0.00	158,320.1781	41,308.0536
P.C. 64+88.48	0.00	158,421.3043	41,481.6752
P.I. 68+85.39	44.20' RT	158,621.0718	41,824.6518
P.T. 72+69.24	0.00	158,948.7124	42,048.6867
POT 81+42.67	0.00	159,669.7021	42,541.6869
P.C. 95+83.49	0.00	160,859.0561	43,354.9464
P.I. 103+12.58	45.70' LT	161,460.8985	43,766.4757
P.T. 110+34.04	0.00	161,942.0080	44,314.2934
POT1 163+20.26 AH = 136+00 BK	0.00	163,635.2283	46,242.2870
POT 222+30.15	0.00	167,535.0310	50,682.8163

THESE BENCHMARKS WERE ESTABLISHED WITH THE 76E84 LEVELS:
 I-55/70 FROM I-64 TO FAIRMOUNT LANE
 D-98-044-11 / 76E84
 DATE OF FIELD WORK: MAY 2021

- B.M. 208: CUT "□" ON TOP SOUTHWEST SIDE OF THE SOUTHWEST CONCRETE OVERHEAD SIGNPOST FOUNDATION OVER I-55/70, NORTH OF I-55/70, JUST NORTHWEST OF THE I-55/70 BRIDGE OVER THE RAILROAD (SN 082-0017). MEASURED ELEVATION: 437.486'
- B.M. 203-7: CUT "X" ON FIRE HYDRANT BOLT AT SOUTH SIDE OF INTERSECTION OF IL 203 AND COLLINSVILLE RD. MEASURED ELEVATION: 407.503'

EXIST. CURVE C1 PI STA. = 68+85.39 Δ = 25° 25' 03" (LT) D = 3° 15' 20" R = 1,759.98' T = 396.91' L = 780.76' E = 44.20' e = _____ T.R. = _____ S.E. RUN = _____ P.C. STA. = 64+88.48 P.T. STA. = 72+69.24	EXIST. CURVE C2 PI STA. = 103+12.58 Δ = 14° 20' 45" (RT) D = 0° 59' 20" R = 5,793.36' T = 729.09' L = 1,450.55' E = 45.70' e = _____ T.R. = _____ S.E. RUN = _____ P.C. STA. = 95+83.49 P.T. STA. = 110+34.04
---	---

MODEL: D:\efk\h
 FILE NAME: 211305229_B60_BR_Bridge\DCN\Design\Final\References\250876K02-shr-ATE1.dgn

EFK Moen
Civil Engineering Design

USER NAME = zWaters	DESIGNED - SJF	REVISED -
PLOT SCALE = 400,000' / in.	DRAWN - ZJB	REVISED -
PLOT DATE = 8/13/2024	CHECKED - SLD	REVISED -
	DATE - 8/13/2024	REVISED -

**STATE OF ILLINOIS
DEPARTMENT OF TRANSPORTATION**

ALIGNMENT, TIES, AND BENCHMARKS

SCALE: N/A SHEET 1 OF 3 SHEETS STA. TO STA.

F.A.I. RTE.	SECTION	COUNTY	TOTAL SHEETS	SHEET NO.
70	82-5V8-R-2	ST. CLAIR	254	27
CONTRACT NO. 76K02				
ILLINOIS FED. AID PROJECT				

MATCHLINE STA 115+00

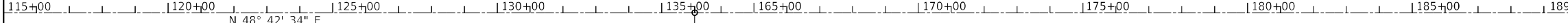

EQUATION:
Sta 136+00.00 BK =
Sta 163+20.26 AH

MATCHLINE STA 190+00

MATCHLINE STA 190+00

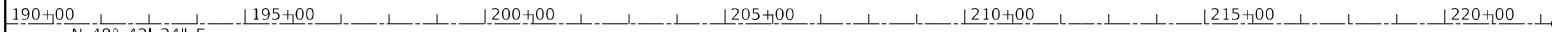

POT 222+30.15

MODEL Path:\n
FILE NAME: Z:\1305229 B&O BR Bridge\DC\Design\Final\Figures\27_0876K02-Sub-A1B2.dgn



USER NAME = zWaters	DESIGNED - SJF	REVISED -
DRAWN - ZJB	REVISED -	
PLOT SCALE = 400,0000 ' / in.	CHECKED - SLD	REVISED -
PLOT DATE = 8/13/2024	DATE - 8/13/2024	REVISED -

STATE OF ILLINOIS
DEPARTMENT OF TRANSPORTATION

ALIGNMENT, TIES, AND BENCHMARKS

SCALE: N/A SHEET 2 OF 3 SHEETS STA. TO STA.

F.A.I. RTE.	SECTION	COUNTY	TOTAL SHEETS	SHEET NO.
70	82-5V8-R-2	ST. CLAIR	254	28
CONTRACT NO. 76K02			ILLINOIS FED. AID PROJECT	

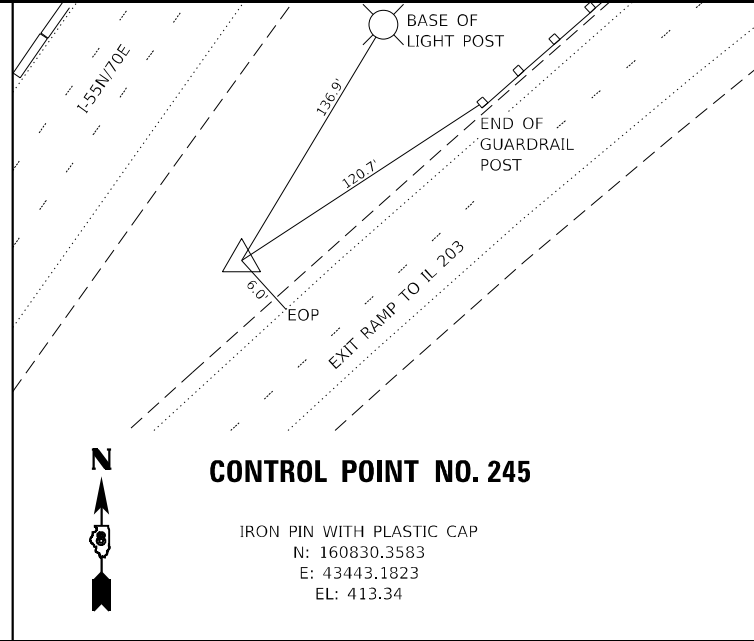
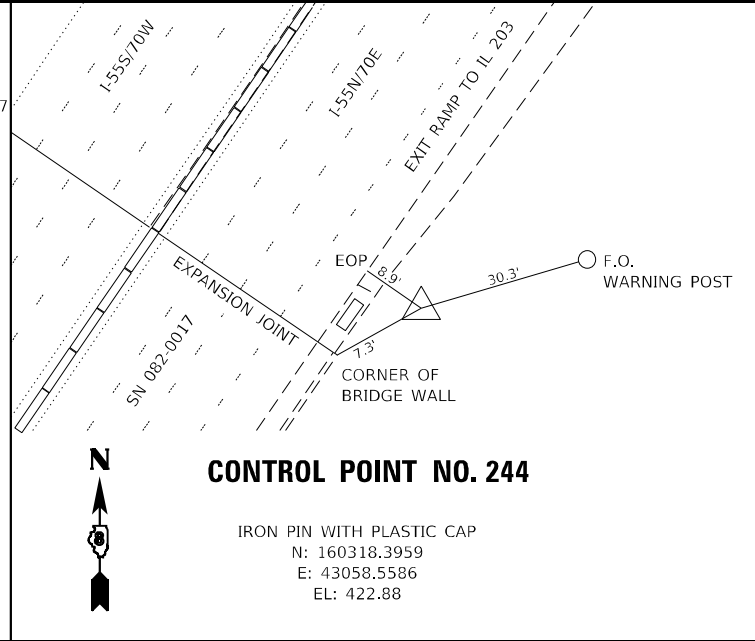
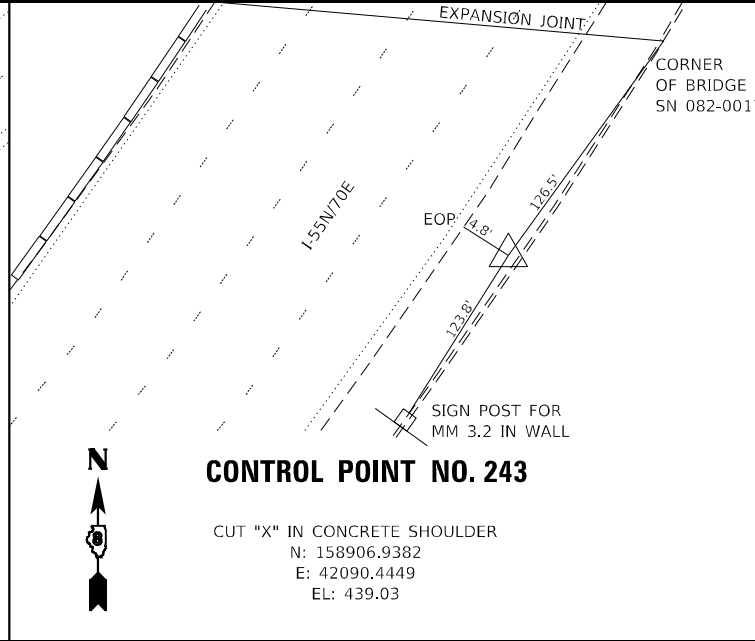
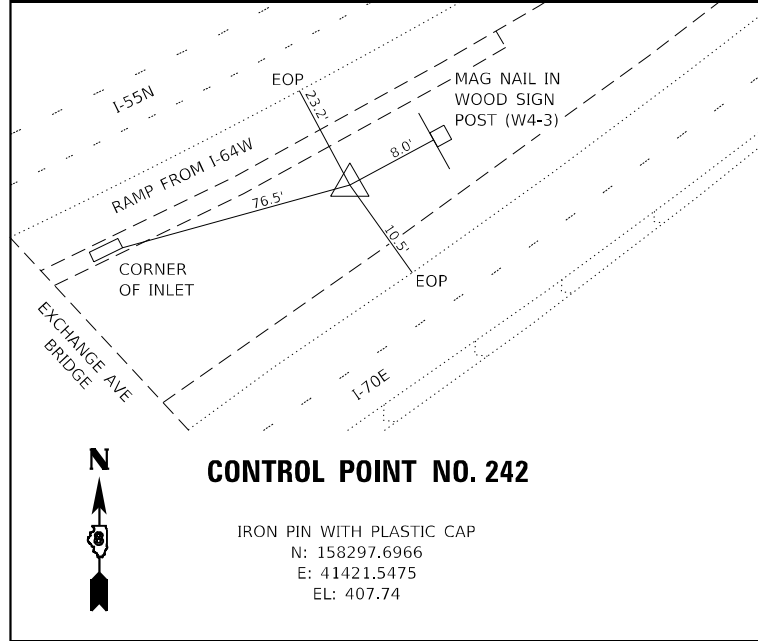
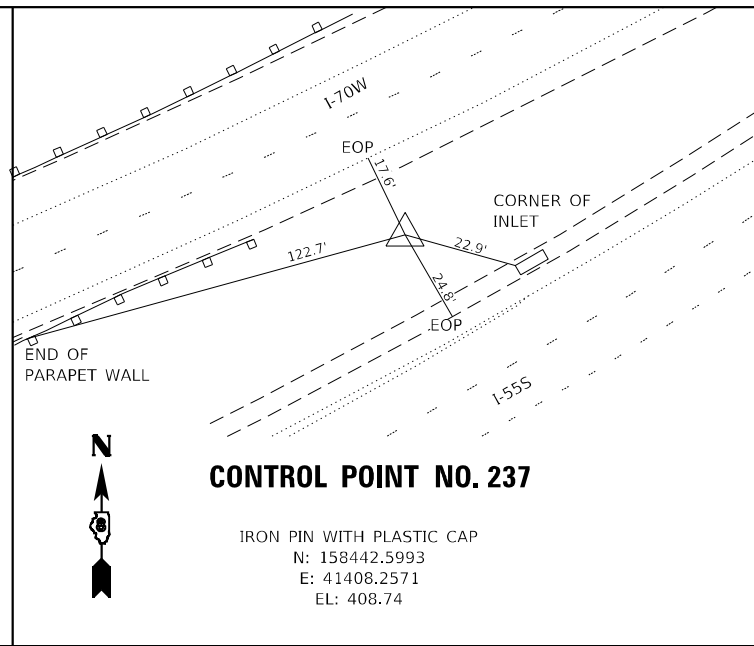
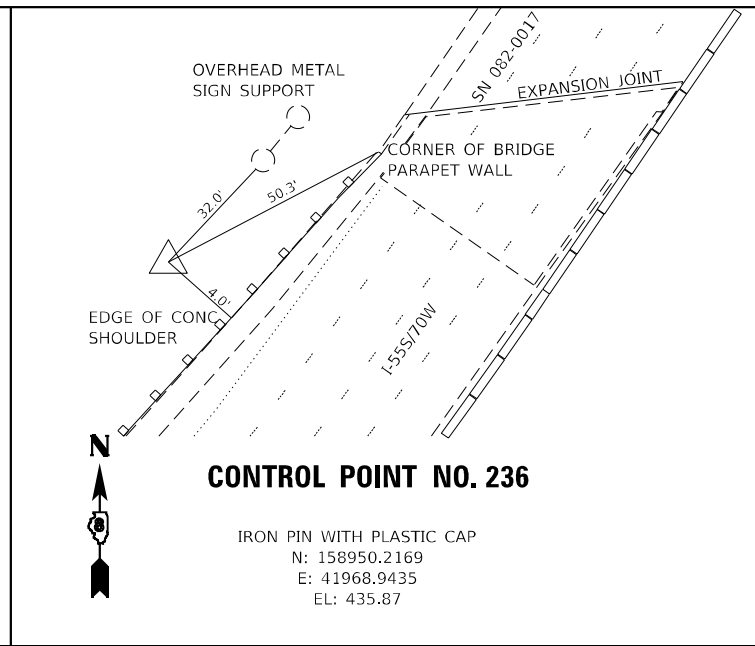
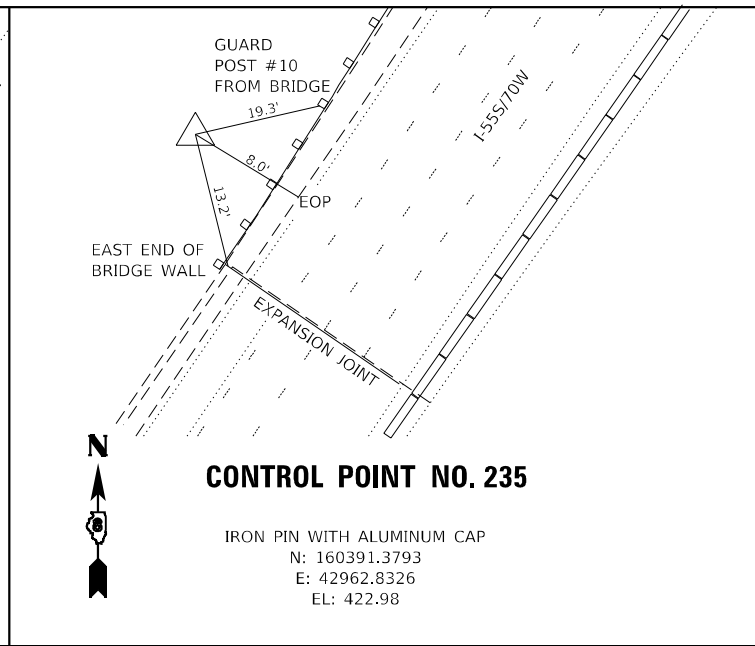
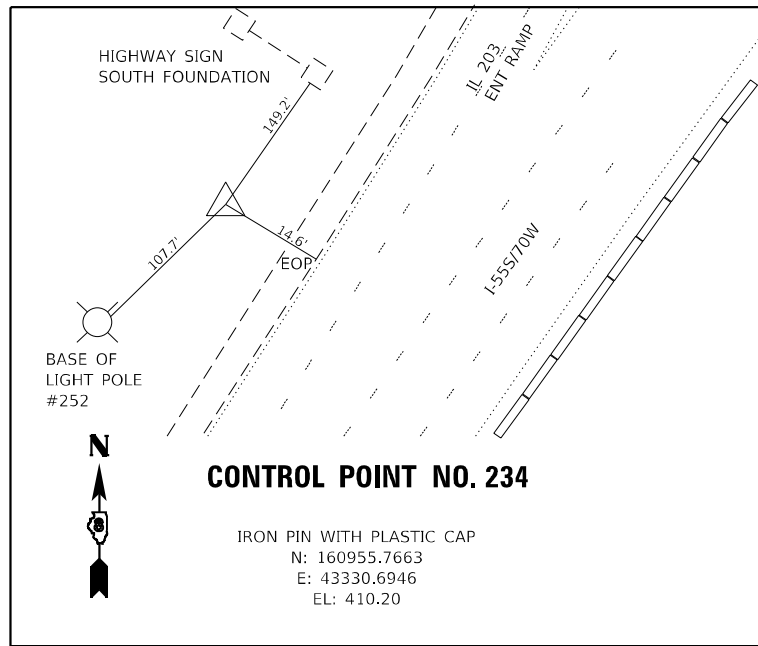

MODEL: D:\efk\I11\B60_BR_Bridge\DCN\Design\I11\B60\B60-02-01-01-01.dwg
 FILE NAME: 211305229 B60_BR_Bridge\DCN\Design\I11\B60\B60-02-01-01-01.dwg



USER NAME = zWaters	DESIGNED - SJF	REVISED -
DRAWN - SJF	REVISED -	
PLOT SCALE = 400,0000' / in.	CHECKED - SLD	REVISED -
PLOT DATE = 8/13/2024	DATE - 8/13/2024	REVISED -



**STATE OF ILLINOIS
DEPARTMENT OF TRANSPORTATION**

ALIGNMENT, TIES, AND BENCHMARKS

SCALE: N/A SHEET 3 OF 3 SHEETS STA. TO STA.

F.A.I. RTE.	SECTION	COUNTY	TOTAL SHEETS	SHEET NO.
70	82-5V8-R-2	ST. CLAIR	254	29
ILLINOIS FED. AID PROJECT			CONTRACT NO. 76K02	

REMOVAL LEGEND

-  - HOT-MIX ASPHALT SURFACE REMOVAL - BUTT JOINT
-  - SHOULDER REMOVAL

NOTES:

1. THE PAVEMENT BETWEEN THE BUTT JOINT AND THE FIRST BRIDGE JOINT SHALL RECEIVE A HOT-MIX ASPHALT SURFACE REMOVAL OF 3/4".
2. SEE DETAIL SHEET 2 FOR RECONSTRUCTION OF BOWMAN YARD ACCESS ROAD.

STA. 71+19.28 TO STA. 72+74.85
TRAFFIC BARRIER TERMINAL, TYPE 2
S.P.B.G.R., TYPE A, 6 FOOT POSTS
TRAFFIC BARRIER TERMINAL, TYPE 5

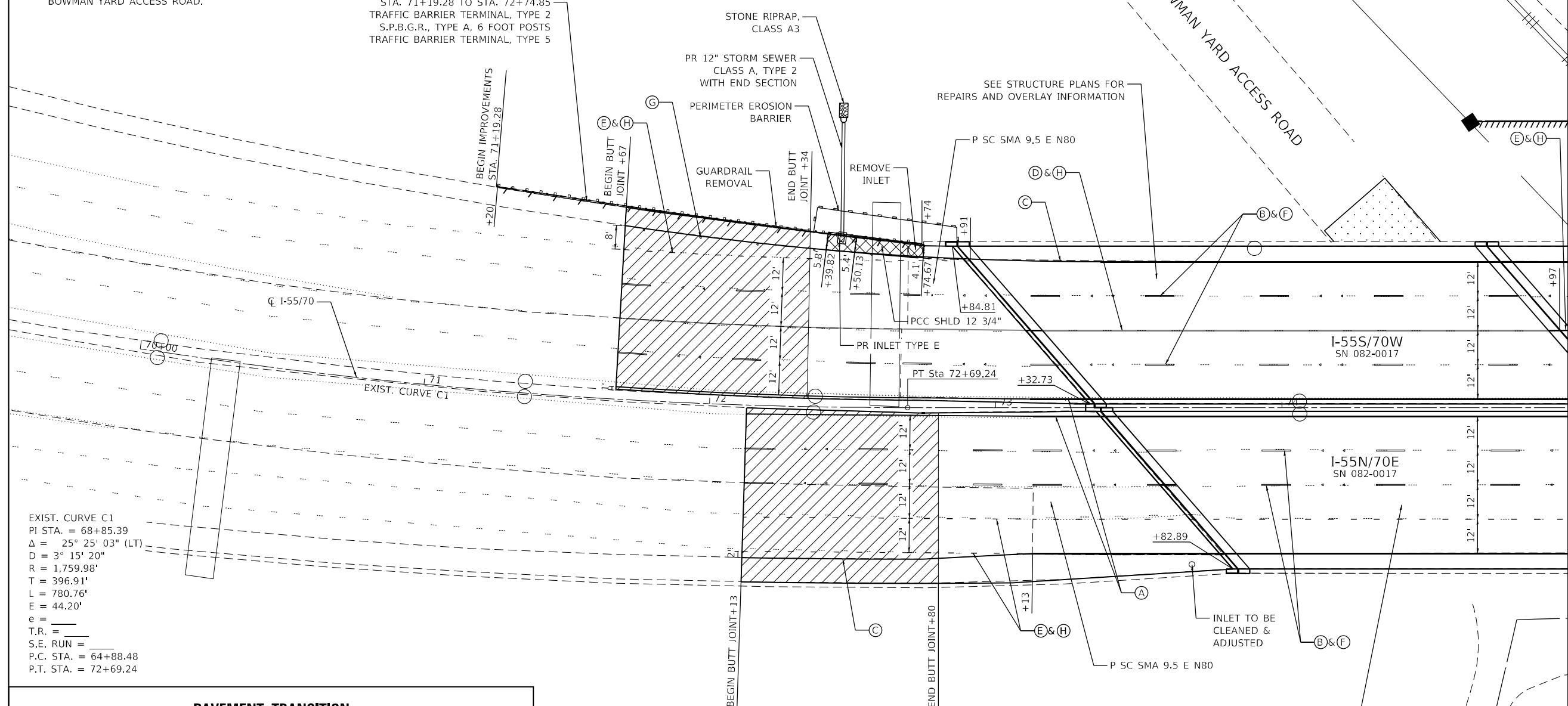

EXIST. CURVE C1
PI STA. = 68+85.39
Δ = 25° 25' 03" (LT)
D = 3° 15' 20"
R = 1,759.98'
T = 396.91'
L = 780.76'
E = 44.20'
e = _____
T.R. = _____
S.E. RUN = _____
P.C. STA. = 64+88.48
P.T. STA. = 72+69.24

PAVEMENT TRANSITION

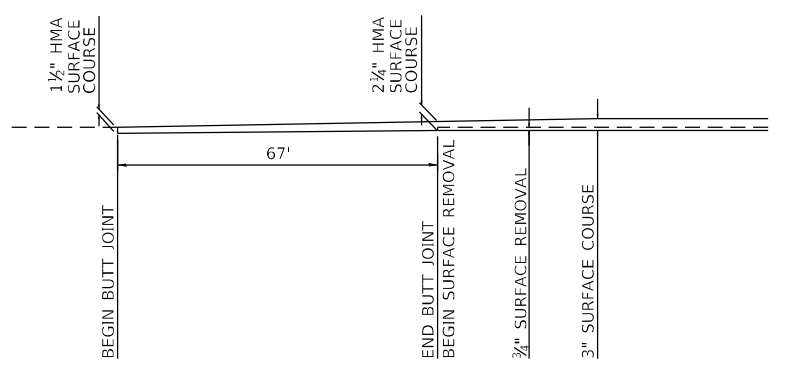

LEGEND

- (A) - 6" PREFORMED PLASTIC PAVEMENT MARKING LINE TYPE B, YELLOW, SOLID EDGE LINE
- (B) - 6" PREFORMED PLASTIC PAVEMENT MARKING LINE, TYPE B, WHITE, SKIP-DASH (30' SKIP 10' DASH)
- (C) - 6" PREFORMED PLASTIC PAVEMENT MARKING LINE TYPE B, WHITE, SOLID, EDGE LINE
- (D) - 8" PREFORMED PLASTIC PAVEMENT MARKING LINE TYPE B, WHITE, SOLID, CHANNELIZATION
- (E) - 8" PREFORMED PLASTIC PAVEMENT MARKING LINE, TYPE B, WHITE, SKIP-DASH (9' SKIP 3' DASH)
- (F) - ONE-WAY CRYSTAL RAISED REFLECTIVE PAVEMENT MARKER 2 @ 80 FT.
- (G) - ONE WAY CRYSTAL RAISED REFLECTIVE PAVEMENT MARKER 1 @ 20 FT
- (H) - ONE WAY CRYSTAL RAISED REFLECTIVE PAVEMENT MARKER 1 @ 80 FT
- (I) - PREFORMED PLASTIC PAVEMENT MARKING, TYPE B, LETTERS AND SYMBOLS

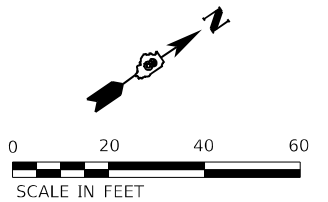

MODEL: 4646.dwg
FILE NAME: Z:\13052-29_BGO_BR_Bridge\DCN\Design\Final\Revised\82-5V8-R-2.dwg
DATE: 8/13/2024

EFK Moen
Civil Engineering Design

USER NAME = zWaters	DESIGNED - SJF	REVISED -
PLOT SCALE = 40,0000' / in.	DRAWN - ZJB	REVISED -
PLOT DATE = 8/13/2024	CHECKED - SLD	REVISED -
	DATE - 8/13/2024	REVISED -



**STATE OF ILLINOIS
DEPARTMENT OF TRANSPORTATION**

PLAN, PAVEMENT MARKING, AND REMOVALS

SCALE: 1"=20' SHEET 1 OF 5 SHEETS STA. 70+00.00 TO STA. 75+00.00

F.A.I. RTE. 70	SECTION 82-5V8-R-2	COUNTY ST. CLAIR	TOTAL SHEETS 254	SHEET NO. 30
CONTRACT NO. 76K02			ILLINOIS FED. AID PROJECT	

REMOVAL LEGEND

-  - HOT-MIX ASPHALT SURFACE REMOVAL - BUTT JOINT
-  - SHOULDER REMOVAL

NOTES:

1. THE PAVEMENT BETWEEN THE BUTT JOINT AND THE FIRST BRIDGE JOINT SHALL RECEIVE A HOT-MIX ASPHALT SURFACE REMOVAL OF 3/4".
2. SEE DETAIL SHEET 2 FOR RECONSTRUCTION OF BOWMAN YARD ACCESS ROAD.

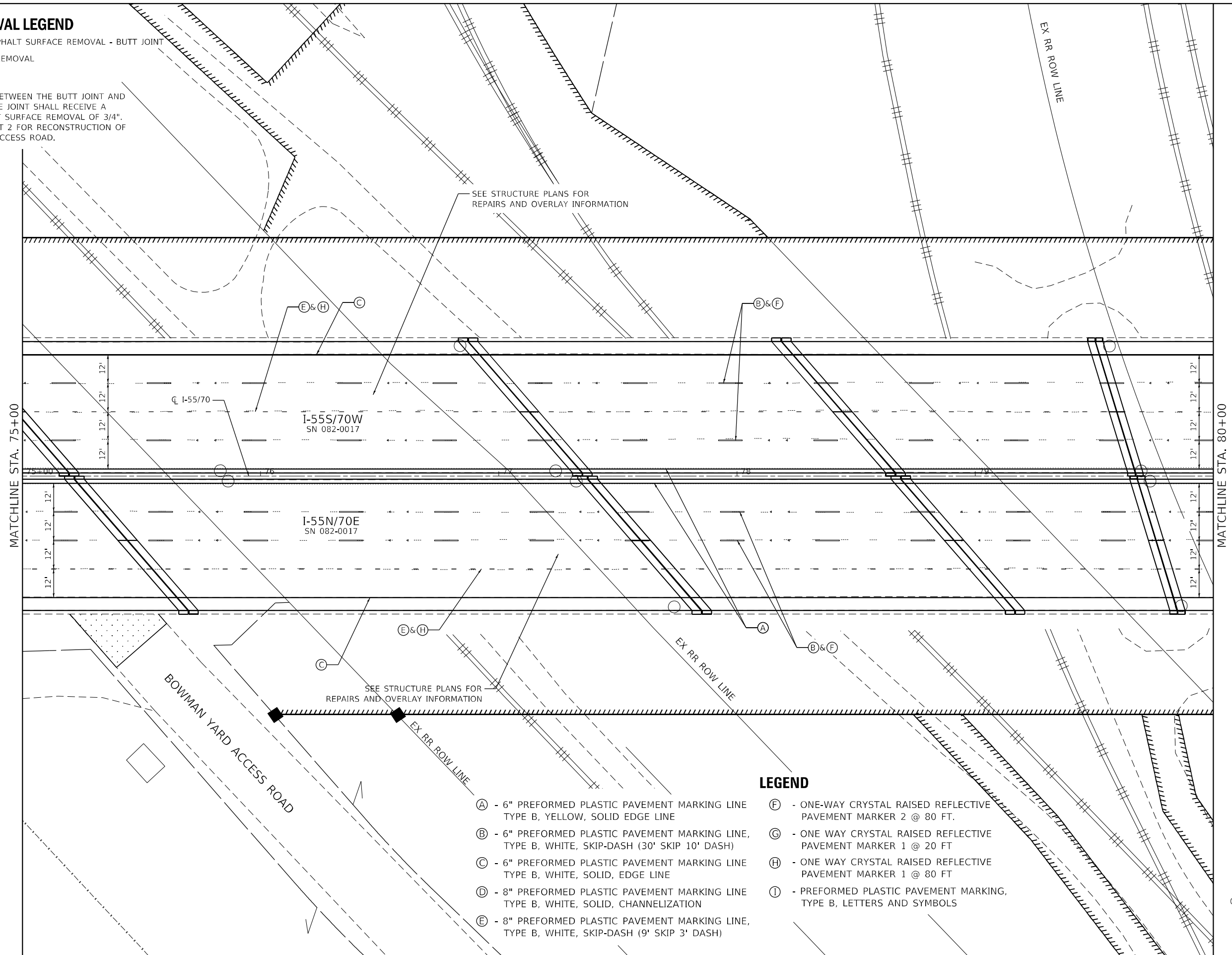

SEE STRUCTURE PLANS FOR REPAIRS AND OVERLAY INFORMATION

SEE STRUCTURE PLANS FOR REPAIRS AND OVERLAY INFORMATION

LEGEND

- (A) - 6" PREFORMED PLASTIC PAVEMENT MARKING LINE TYPE B, YELLOW, SOLID EDGE LINE
- (B) - 6" PREFORMED PLASTIC PAVEMENT MARKING LINE, TYPE B, WHITE, SKIP-DASH (30' SKIP 10' DASH)
- (C) - 6" PREFORMED PLASTIC PAVEMENT MARKING LINE TYPE B, WHITE, SOLID, EDGE LINE
- (D) - 8" PREFORMED PLASTIC PAVEMENT MARKING LINE TYPE B, WHITE, SOLID, CHANNELIZATION
- (E) - 8" PREFORMED PLASTIC PAVEMENT MARKING LINE, TYPE B, WHITE, SKIP-DASH (9' SKIP 3' DASH)
- (F) - ONE-WAY CRYSTAL RAISED REFLECTIVE PAVEMENT MARKER 2 @ 80 FT.
- (G) - ONE WAY CRYSTAL RAISED REFLECTIVE PAVEMENT MARKER 1 @ 20 FT
- (H) - ONE WAY CRYSTAL RAISED REFLECTIVE PAVEMENT MARKER 1 @ 80 FT
- (I) - PREFORMED PLASTIC PAVEMENT MARKING, TYPE B, LETTERS AND SYMBOLS

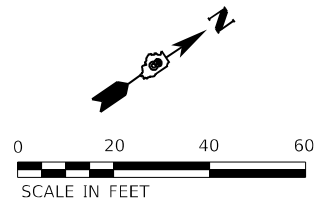

MODEL: 4646.dwg
 FILE NAME: Z:\13052-29_B&O_BR_Bridge\DCN\Design\Final\Fiber\Sheet30_0876K02_civ-pls-02.dgn



USER NAME = zWaters	DESIGNED - SJF	REVISED -
DRAWN - ZJB	REVISED -	
PLOT SCALE = 40,0000 * / in.	CHECKED - SLD	REVISED -
PLOT DATE = 8/13/2024	DATE - 8/13/2024	REVISED -



**STATE OF ILLINOIS
DEPARTMENT OF TRANSPORTATION**

PLAN, PAVEMENT MARKING, AND REMOVALS

SCALE: 1"=20' SHEET 2 OF 5 SHEETS STA. 75+00.00 TO STA. 80+00.00

F.A.I. RTE.	SECTION	COUNTY	TOTAL SHEETS	SHEET NO.
70	82-5V8-R-2	ST. CLAIR	254	31
CONTRACT NO. 76K02				
ILLINOIS FED. AID PROJECT				

REMOVAL LEGEND

-  - HOT-MIX ASPHALT SURFACE REMOVAL - BUTT JOINT
-  - SHOULDER REMOVAL

NOTES:

1. THE PAVEMENT BETWEEN THE BUTT JOINT AND THE FIRST BRIDGE JOINT SHALL RECEIVE A HOT-MIX ASPHALT SURFACE REMOVAL OF 3/4".
2. SEE DETAIL SHEET 2 FOR RECONSTRUCTION OF BOWMAN YARD ACCESS ROAD.

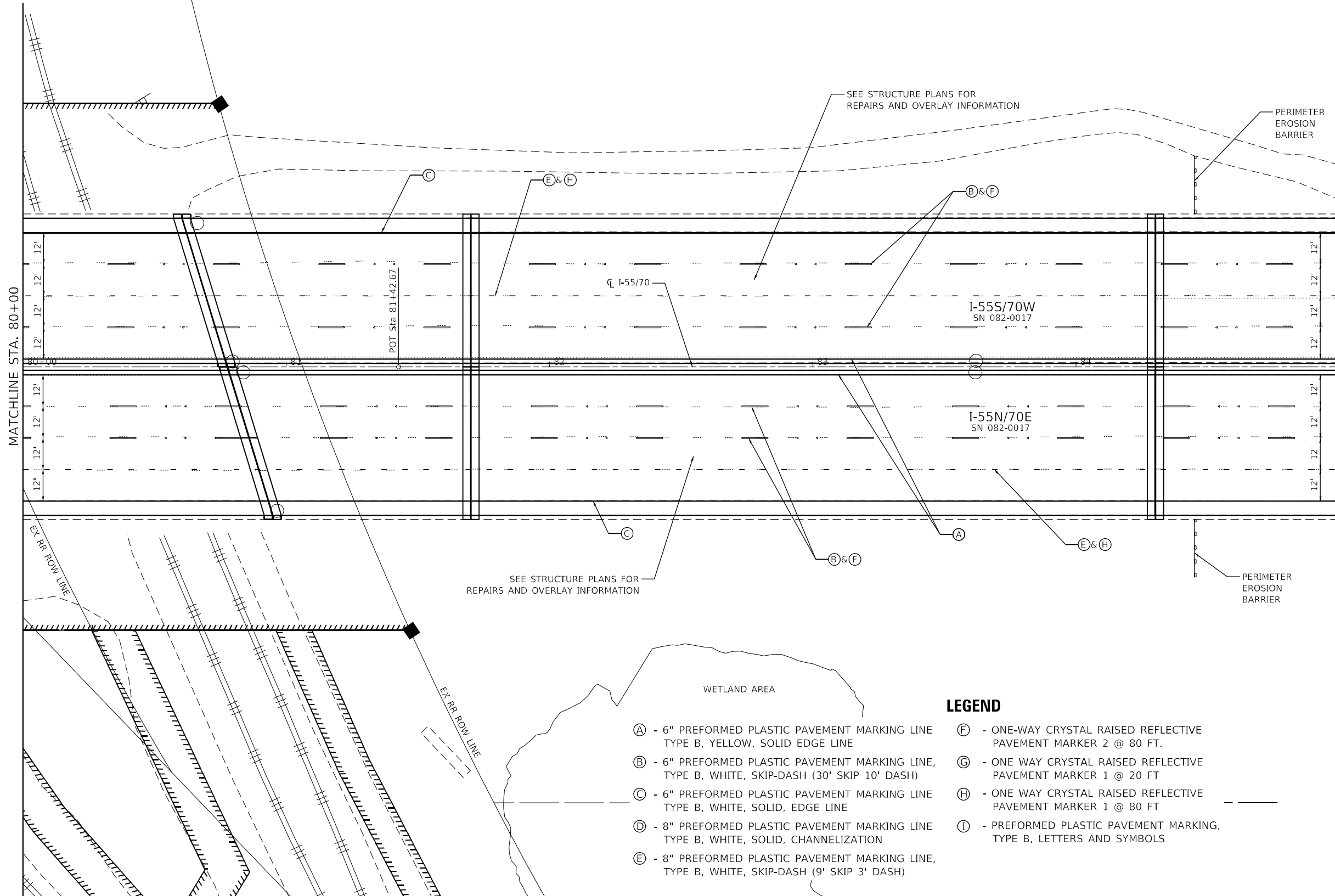

LEGEND

- (A) - 6" PREFORMED PLASTIC PAVEMENT MARKING LINE TYPE B, YELLOW, SOLID EDGE LINE
- (B) - 6" PREFORMED PLASTIC PAVEMENT MARKING LINE, TYPE B, WHITE, SKIP-DASH (30' SKIP 10' DASH)
- (C) - 6" PREFORMED PLASTIC PAVEMENT MARKING LINE TYPE B, WHITE, SOLID, EDGE LINE
- (D) - 8" PREFORMED PLASTIC PAVEMENT MARKING LINE TYPE B, WHITE, SOLID, CHANNELIZATION
- (E) - 8" PREFORMED PLASTIC PAVEMENT MARKING LINE, TYPE B, WHITE, SKIP-DASH (9' SKIP 3' DASH)
- (F) - ONE-WAY CRYSTAL RAISED REFLECTIVE PAVEMENT MARKER 2 @ 80 FT.
- (G) - ONE WAY CRYSTAL RAISED REFLECTIVE PAVEMENT MARKER 1 @ 20 FT
- (H) - ONE WAY CRYSTAL RAISED REFLECTIVE PAVEMENT MARKER 1 @ 80 FT
- (I) - PREFORMED PLASTIC PAVEMENT MARKING, TYPE B, LETTERS AND SYMBOLS

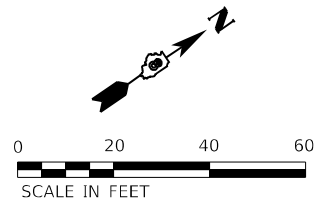

MODEL: 4646.dwg
 FILE NAME: Z:\13052-29_B60_BR_Bridge\DC\Design\Final\Fiber\Sheet31-D878K02_sht-eps03.dgn

EFK Moen
Civil Engineering Design

USER NAME = zWaters	DESIGNED - SJF	REVISED -
	DRAWN - ZJB	REVISED -
PLOT SCALE = 40,0000 * / in.	CHECKED - SLD	REVISED -
PLOT DATE = 8/13/2024	DATE - 8/13/2024	REVISED -



**STATE OF ILLINOIS
DEPARTMENT OF TRANSPORTATION**

PLAN, PAVEMENT MARKING, AND REMOVALS

SCALE: 1"=20' SHEET 3 OF 5 SHEETS STA. 80+00.00 TO STA. 85+00.00

F.A.I. RTE. 70	SECTION 82-5V8-R-2	COUNTY ST. CLAIR	TOTAL SHEETS 254	SHEET NO. 32
			CONTRACT NO. 76K02	
ILLINOIS FED. AID PROJECT				

REMOVAL LEGEND

-  - HOT-MIX ASPHALT SURFACE REMOVAL - BUTT JOINT
-  - SHOULDER REMOVAL

NOTES:

1. THE PAVEMENT BETWEEN THE BUTT JOINT AND THE FIRST BRIDGE JOINT SHALL RECEIVE A HOT-MIX ASPHALT SURFACE REMOVAL OF 3/4".
2. SEE DETAIL SHEET 2 FOR RECONSTRUCTION OF BOWMAN YARD ACCESS ROAD.

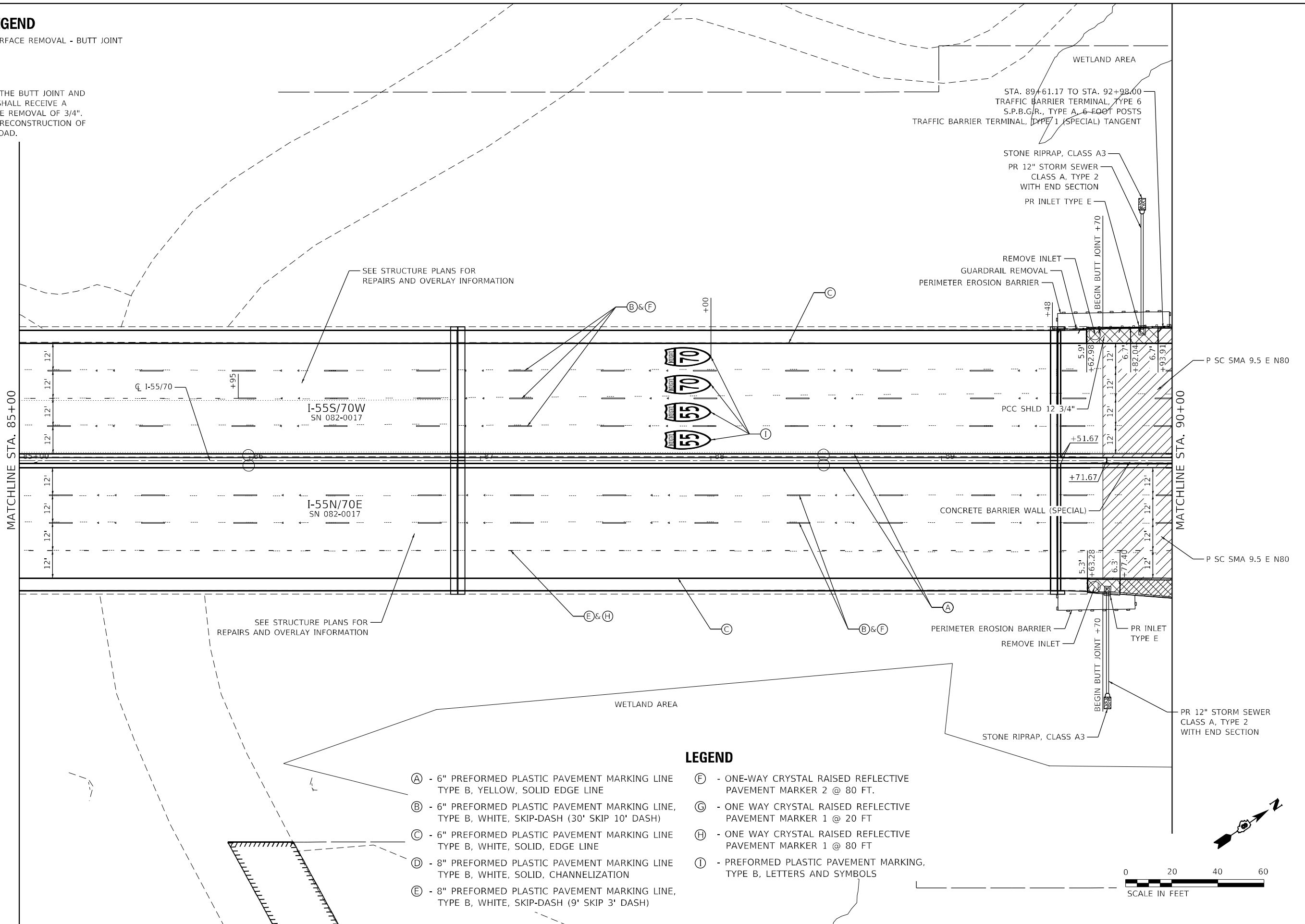

LEGEND

- (A) - 6" PREFORMED PLASTIC PAVEMENT MARKING LINE TYPE B, YELLOW, SOLID EDGE LINE
- (B) - 6" PREFORMED PLASTIC PAVEMENT MARKING LINE, TYPE B, WHITE, SKIP-DASH (30' SKIP 10' DASH)
- (C) - 6" PREFORMED PLASTIC PAVEMENT MARKING LINE TYPE B, WHITE, SOLID, EDGE LINE
- (D) - 8" PREFORMED PLASTIC PAVEMENT MARKING LINE TYPE B, WHITE, SOLID, CHANNELIZATION
- (E) - 8" PREFORMED PLASTIC PAVEMENT MARKING LINE, TYPE B, WHITE, SKIP-DASH (9' SKIP 3' DASH)
- (F) - ONE-WAY CRYSTAL RAISED REFLECTIVE PAVEMENT MARKER 2 @ 80 FT.
- (G) - ONE WAY CRYSTAL RAISED REFLECTIVE PAVEMENT MARKER 1 @ 20 FT
- (H) - ONE WAY CRYSTAL RAISED REFLECTIVE PAVEMENT MARKER 1 @ 80 FT
- (I) - PREFORMED PLASTIC PAVEMENT MARKING, TYPE B, LETTERS AND SYMBOLS

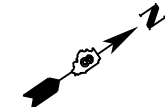

MODEL: 4646.dwg
 FILE NAME: Z:\13052229_B60_BR_Bridge\DCN\Design\Final\Fiber\Sheet32_0878K02_cbr-pls04.dgn



USER NAME = zWaters	DESIGNED - SJF	REVISED -
DRAWN - ZJB	REVISED -	
PLOT SCALE = 40,0000 * / in.	CHECKED - SLD	REVISED -
PLOT DATE = 8/13/2024	DATE - 8/13/2024	REVISED -



**STATE OF ILLINOIS
DEPARTMENT OF TRANSPORTATION**

PLAN, PAVEMENT MARKING, AND REMOVALS

SCALE: 1"=20' SHEET 4 OF 5 SHEETS STA. 85+00.00 TO STA. 90+00.00

F.A.I. RTE.	SECTION	COUNTY	TOTAL SHEETS	SHEET NO.
70	82-5V8-R-2	ST. CLAIR	254	33
CONTRACT NO. 76K02				
ILLINOIS FED. AID PROJECT				

REMOVAL LEGEND

-  - HOT-MIX ASPHALT SURFACE REMOVAL - BUTT JOINT
-  - SHOULDER REMOVAL

- NOTES:
1. THE PAVEMENT BETWEEN THE BUTT JOINT AND THE FIRST BRIDGE JOINT SHALL RECEIVE A HOT-MIX ASPHALT SURFACE REMOVAL OF 3/4".
 2. SEE DETAIL SHEET 2 FOR RECONSTRUCTION OF BOWMAN YARD ACCESS ROAD.

PAVEMENT TRANSITION

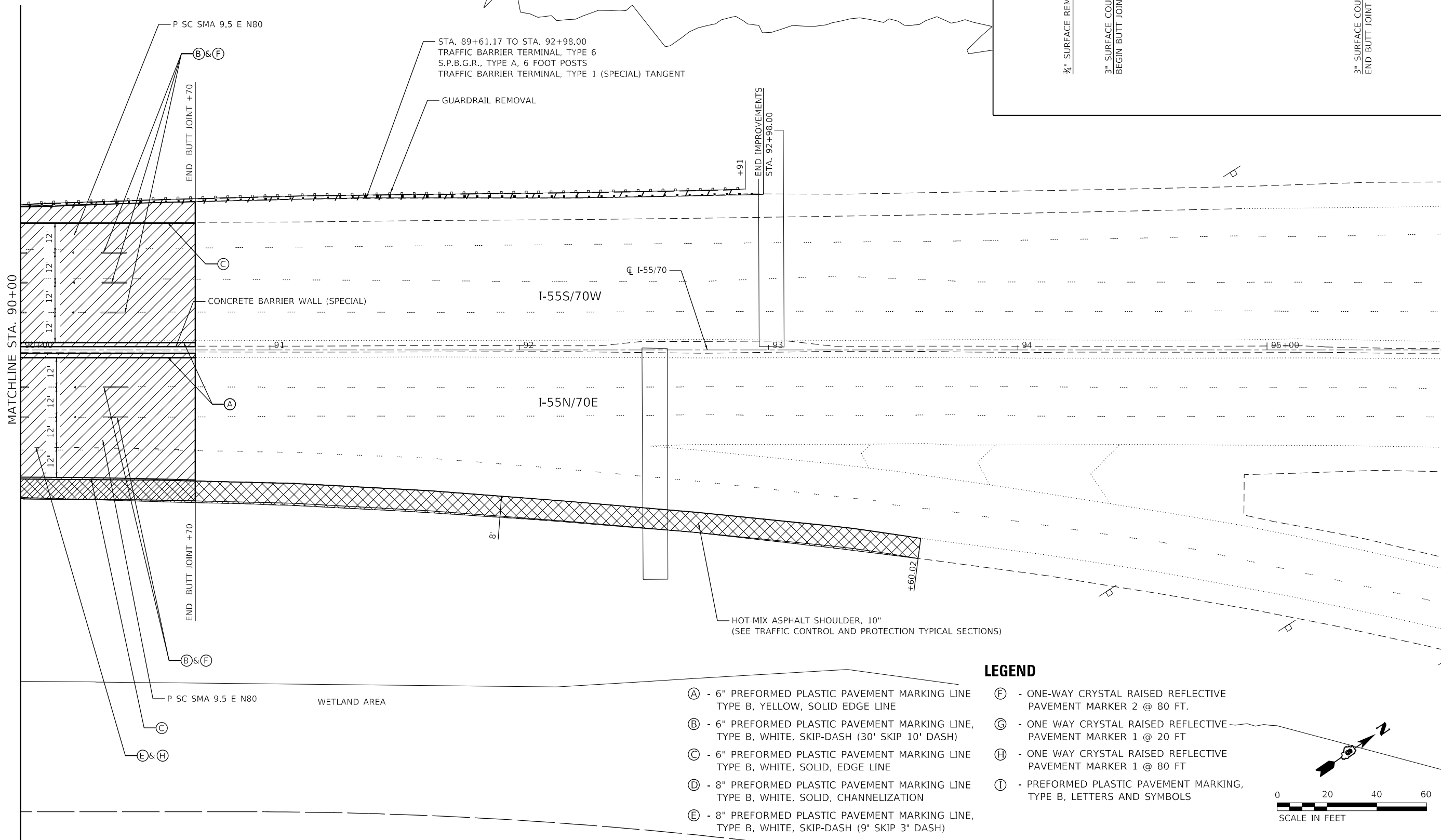
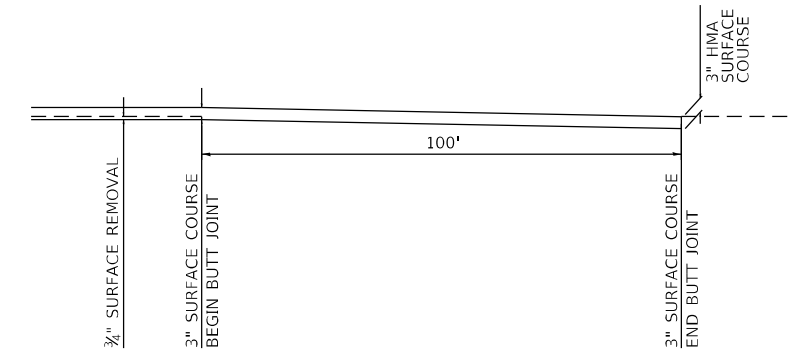

LEGEND

- (A) - 6" PREFORMED PLASTIC PAVEMENT MARKING LINE TYPE B, YELLOW, SOLID EDGE LINE
- (B) - 6" PREFORMED PLASTIC PAVEMENT MARKING LINE, TYPE B, WHITE, SKIP-DASH (30' SKIP 10' DASH)
- (C) - 6" PREFORMED PLASTIC PAVEMENT MARKING LINE TYPE B, WHITE, SOLID, EDGE LINE
- (D) - 8" PREFORMED PLASTIC PAVEMENT MARKING LINE TYPE B, WHITE, SOLID, CHANNELIZATION
- (E) - 8" PREFORMED PLASTIC PAVEMENT MARKING LINE, TYPE B, WHITE, SKIP-DASH (9' SKIP 3' DASH)
- (F) - ONE-WAY CRYSTAL RAISED REFLECTIVE PAVEMENT MARKER 2 @ 80 FT.
- (G) - ONE WAY CRYSTAL RAISED REFLECTIVE PAVEMENT MARKER 1 @ 20 FT
- (H) - ONE WAY CRYSTAL RAISED REFLECTIVE PAVEMENT MARKER 1 @ 80 FT
- (I) - PREFORMED PLASTIC PAVEMENT MARKING, TYPE B, LETTERS AND SYMBOLS

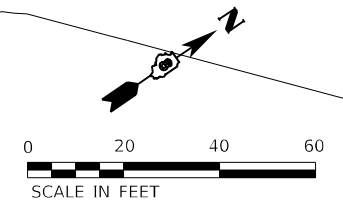

MODEL: D:\efk\11... FILE NAME: 211305229_B60_BR_Bridge\DCN\Design\Final\Fiber\Sheet33-076K02_civ-eps05.dgn



USER NAME = zWaters	DESIGNED - SJF	REVISED -
	DRAWN - ZJB	REVISED -
PLOT SCALE = 40,0000 * / in.	CHECKED - SLD	REVISED -
PLOT DATE = 8/13/2024	DATE - 8/13/2024	REVISED -

**STATE OF ILLINOIS
DEPARTMENT OF TRANSPORTATION**

PLAN, PAVEMENT MARKING, AND REMOVALS

SCALE: 1"=20' SHEET 5 OF 5 SHEETS STA. 90+00.00 TO STA. 95+00.00

F.A.I. RTE.	SECTION	COUNTY	TOTAL SHEETS	SHEET NO.
70	82-5V8-R-2	ST. CLAIR	254	34
CONTRACT NO. 76K02				
ILLINOIS FED. AID PROJECT				

TRAFFIC CONTROL AND PROTECTION GENERAL NOTES

- ALL REQUIRED TRAFFIC CONTROL SHALL BE CONDUCTED IN ACCORDANCE WITH ALL CURRENT APPLICABLE IDOT POLICIES AND STANDARDS AND THE LATEST EDITION OF THE MANUAL ON UNIFORM TRAFFIC CONTROL DEVICES (MUTCD) IN EFFECT ON THE DATE OF THE INVITATION FOR BIDS.
- ALL TRAFFIC CONTROL SHALL BE IN PLACE PRIOR TO THE START OF CONSTRUCTION. THE CONTRACTOR IS REQUIRED TO NOTIFY THE RESIDENT ENGINEER 21 DAYS IN ADVANCE OF THE PLACEMENT OF ANY TEMPORARY TRAFFIC CONTROL DEVICES.
- 21 DAYS PRIOR TO ANY LANE CLOSURE THE CONTRACTOR SHALL NOTIFY THE RESIDENT ENGINEER.
- FOUR CHANGEABLE MESSAGE SIGNS SHALL BE REQUIRED FOR THIS PROJECT. THEY SHALL BE PLACED TWO WEEKS PRIOR TO ANY LANE CLOSURE, SHALL REMAIN UP FOR THE DURATION OF THE PROJECT, AND SHALL BE PLACED AS SHOWN ON THE PLANS, HIGHWAY STANDARDS, OR AT THE DIRECTION OF THE ENGINEER. ALL MESSAGES SHOWN ON THE CMS SHALL BE APPROVED BY THE RESIDENT ENGINEER. THROUGH STAGE 5 THE CHANGEABLE MESSAGE SIGNS SHALL BE PLACED ALONG I-55N/64E, ALONG I-64W, ALONG I-70E, ALONG I-255S, OR AT THE DIRECTION OF THE ENGINEER. AFTER STAGE 5 THE CHANGEABLE MESSAGE SIGNS SHALL BE PLACED ALONG I-55S/70W, ALONG I-255S, ALONG IL ROUTE 203S, ALONG IL ROUTE 203N, OR AT THE DIRECTION OF THE ENGINEER.
- ADVANCED SIGNING OF THE NARROW STAGING WIDTHS FOR REPAIRS DURING STAGES 2, 4, AND 7 SHALL BE PLACED ALONG THE I-55S/70W PRIOR TO THE I-255 INTERCHANGE, AND ALONG I-55N/64E PRIOR TO THE TRI-LEVEL INTERCHANGE OR AT THE DIRECTION OF THE ENGINEER. ALL CONSTRUCTION SIGNS SHALL BE 48"x48" FLUORESCENT ORANGE.
- FLAGGER SHALL BE REQUIRED AT ALL TIMES WHEN WORKERS OR EQUIPMENT ARE ENCROACHING INTO THE LANE OF TRAFFIC.
- CONSTRUCTION OF THE PRESTAGE SHALL BE COMPLETED PRIOR TO BEGINNING SUBSEQUENT STAGES.
- 21 DAYS PRIOR TO ANY LANE CLOSURES, THE ENGINEER WILL CONTACT THE AGENCIES LISTED BELOW:
 - ST. CLAIR COUNTY TRANSIT DISTRICT, (618) 628-8090, ATTN.: BILL GROGAN
 - MADISON COUNTY TRANSIT DISTRICT, FAX: (618) 797-7547
 - CITY OF EAST ST. LOUIS POLICE DEPARTMENT, (618) 482-6767
 - CITY OF EAST ST. LOUIS FIRE DEPARTMENT, (618) 482-6840
 - VILLAGE OF FAIRMONT CITY FIRE DEPARTMENT, (618) 274-4504
 - VILLAGE OF FAIRMONT CITY POLICE DEPARTMENT, (618) 274-4504
 - ST. CLAIR COUNTY EMERGENCY TELEPHONE SYSTEM BOARD, FAX (618) 277-7688, ATTN.: CAROLYN LIGON
 - DISTRICT 8 TRAFFIC MANAGEMENT CENTER, (618) 346-3233
- 15-MINUTE FULL TRAFFIC STOPS OF ALL LANES ALONG I-55/70 WILL BE NECESSARY FOR THE INITIAL APPLICATION OF JACKING LOADS DURING SUBSTRUCTURE REPLACEMENT. THE INTERMEDIATE CLOSURES WILL ONLY BE PERMITTED DURING THE OFF-PEAK HOURS OF TRAVEL AND SHALL BE APPROVED BY THE ENGINEER.
- WHEN WORKING UNDER THE STRUCTURE, "BUMP" SIGNS (W8-1) SHALL BE INSTALLED AS NEEDED AND THE PLACEMENT OF THE SIGN(S) SHALL BE APPROVED BY THE ENGINEER TO IDENTIFY LOCATIONS OF DIFFERENTIAL GRADE CHANGES ASSOCIATED WITH SUBSTRUCTURE REPLACEMENT.

SUGGESTED SEQUENCE OF CONSTRUCTION (ON THE BRIDGE DECKS)

- TRAFFIC CONTROL AND PROTECTION PLAN PRESTAGE
- INSTALL CONSTRUCTION SIGNING AND TRAFFIC CONTROL DEVICES AS SHOWN ON THE PRESTAGE CONSTRUCTION PLANS AND APPROPRIATE HIGHWAY STANDARDS.
 - REPLACE THE OUTSIDE HMA SHOULDERS AND AGGREGATE SHOULDER WEDGE ALONG I-55S/70W FROM STA. 98+08 LT - STA. 102+90 LT AND ALONG I-55N/70E FROM STA. 89+68 RT - STA. 93+60 RT.
- TRAFFIC CONTROL AND PROTECTION PLAN STAGE 1
- INSTALL CONSTRUCTION SIGNING AND TRAFFIC CONTROL DEVICES AS SHOWN ON THE STAGE 1 CONSTRUCTION PLANS AND APPROPRIATE HIGHWAY STANDARDS. INSTALL DETOUR SIGNING AS SHOWN ON THE STAGES 1-4A DETOUR SIGNING DETAIL AND ALTERNATE ROUTE SIGNING FOR I-55N/70E AS SHOWN ON THE ALTERNATE ROUTE SIGNING DETAIL.
 - CLOSE RAMP 64W55N, RAMP P, AND RAMP 70E55N TO ALL TRAFFIC.
 - INSTALL THE STRONG BACK SUPPORT ALONG THE INSIDE TWO LANES OF I-55N/70E ACROSS PIER 7 OF THE B&O BRIDGE.
 - BEGIN REPAIRS TO PIERS 7 AND 9 OF THE B&O BRIDGE ALONG I-55N/70E.
- TRAFFIC CONTROL AND PROTECTION PLAN STAGE 2
- INSTALL CONSTRUCTION SIGNING AND TRAFFIC CONTROL DEVICES AS SHOWN ON THE STAGE 2 CONSTRUCTION PLANS AND APPROPRIATE HIGHWAY STANDARDS.
 - RAMP 64W55N, RAMP P, AND RAMP 70E55N ARE CLOSED TO ALL TRAFFIC.
 - INSTALL THE STRONG BACK SUPPORT ALONG THE OUTSIDE TWO LANES OF I-55N/70E ACROSS PIER 7 OF THE B&O BRIDGE.
 - COMPLETE REPAIRS TO PIERS 7 AND 9 OF THE B&O BRIDGE ALONG I-55N/70E.
- TRAFFIC CONTROL AND PROTECTION PLAN STAGE 3
- INSTALL CONSTRUCTION SIGNING AND TRAFFIC CONTROL DEVICES AS SHOWN ON THE STAGE 3 CONSTRUCTION PLANS AND APPROPRIATE HIGHWAY STANDARDS.
 - RAMP 64W55N, RAMP P, AND RAMP 70E55N ARE CLOSED TO ALL TRAFFIC.
 - CONSTRUCT REPAIRS LOCATED ALONG THE INSIDE TWO LANES OF THE B&O BRIDGE ALONG I-55N/70E.
 - MILL AND OVERLAY THE INSIDE LANES ALONG I-55N/70E.
- TRAFFIC CONTROL AND PROTECTION PLAN STAGE 4
- INSTALL CONSTRUCTION SIGNING AND TRAFFIC CONTROL DEVICES AS SHOWN ON THE STAGE 4 CONSTRUCTION PLANS AND APPROPRIATE HIGHWAY STANDARDS.
 - RAMP 64W55N, RAMP P, AND RAMP 70E55N ARE CLOSED TO ALL TRAFFIC.
 - CONSTRUCT REPAIRS LOCATED ALONG THE OUTSIDE TWO LANES OF THE B&O BRIDGE ALONG I-55N/70E TO STA. 88+22 RT.
- TRAFFIC CONTROL AND PROTECTION PLAN STAGE 4A
- INSTALL CONSTRUCTION SIGNING AND TRAFFIC CONTROL DEVICES AS SHOWN ON THE STAGE 4A CONSTRUCTION PLANS AND APPROPRIATE HIGHWAY STANDARDS. INSTALL DETOUR SIGNING AS SHOWN ON THE STAGE 4A DETOUR SIGNING DETAIL.
 - RAMP 64W55N, RAMP P, AND RAMP 70E55N ARE CLOSED TO ALL TRAFFIC.
 - CLOSE RAMP 55N203 TO ALL TRAFFIC.
 - COMPLETE REPAIRS TO THE OUTSIDE TWO LANES OF THE B&O BRIDGE ALONG I-55N/70E.
 - MILL AND OVERLAY THE OUTSIDE LANES OF I-55N/70E.
- TRAFFIC CONTROL AND PROTECTION PLAN STAGE 5
- OPEN ALL LANES OF I-55N/70E, RAMP 64W55N, RAMP P, AND RAMP 70E55N TO TRAFFIC.
 - INSTALL FINAL PAVEMENT MARKINGS ALONG I-55N/70E AS SHOWN ON THE PLAN SHEETS.
- TRAFFIC CONTROL AND PROTECTION PLAN STAGE 6
- INSTALL CONSTRUCTION SIGNING AND TRAFFIC CONTROL DEVICES AS SHOWN ON THE STAGE 6 CONSTRUCTION PLANS AND APPROPRIATE HIGHWAY STANDARDS. INSTALL DETOUR SIGNING AS SHOWN ON THE STAGES 6-7 DETOUR SIGNING DETAIL AND ALTERNATE ROUTE SIGNING FOR I-55S/70W AS SHOWN ON THE ALTERNATE ROUTE SIGNING DETAIL.
 - CLOSE RAMP 203S55S AND THE EXIT RAMP TO EXCHANGE AVENUE TO ALL TRAFFIC.
 - CONSTRUCT REPAIRS LOCATED ALONG THE INSIDE TWO LANES OF THE B&O BRIDGE ALONG I-55S/70W.
 - MILL AND OVERLAY THE INSIDE LANES OF I-55S/70W.
- TRAFFIC CONTROL AND PROTECTION PLAN STAGE 7
- INSTALL CONSTRUCTION SIGNING AND TRAFFIC CONTROL DEVICES AS SHOWN ON THE STAGE 7 CONSTRUCTION PLANS AND APPROPRIATE HIGHWAY STANDARDS.
 - RAMP 203S55S AND THE EXIT RAMP TO EXCHANGE AVENUE ARE CLOSED TO ALL TRAFFIC.
 - CONSTRUCT REPAIRS LOCATED ALONG THE OUTSIDE TWO LANES OF THE B&O BRIDGE OF I-55S/70W.
 - MILL AND OVERLAY THE OUTSIDE LANES ALONG I-55S/70W.
- TRAFFIC CONTROL AND PROTECTION PLAN STAGE 8
- OPEN ALL LANES I-55S/70W, RAMP 203S55S AND THE EXIT RAMP TO EXCHANGE AVENUE TO TRAFFIC.
 - INSTALL FINAL PAVEMENT MARKINGS ALONG I-55S/70W AS SHOWN ON THE PLAN SHEETS.

MODEL Path: \\...
 FILE NAME: 211305229 B&O BR BridgeDCN\Design\Final\B&O-Sub-01.dgn



USER NAME = zWaters	DESIGNED - SJF	REVISED -
	DRAWN - SJF	REVISED -
PLOT SCALE = 100,0000' / in.	CHECKED - SLD	REVISED -
PLOT DATE = 8/13/2024	DATE - 8/13/2024	REVISED -

**STATE OF ILLINOIS
DEPARTMENT OF TRANSPORTATION**

TRAFFIC CONTROL AND PROTECTION GENERAL NOTES & SUGGESTED SEQUENCE OF CONSTRUCTION (ON THE BRIDGE DECK)			
SCALE: N/A	SHEET 1	OF 5>TFC SHEETS	STA. TO STA.

F.A.I. RTE.	SECTION	COUNTY	TOTAL SHEETS	SHEET NO.
70	82-5V8-R-2	ST. CLAIR	254	35
CONTRACT NO. 76K02			ILLINOIS FED. AID PROJECT	

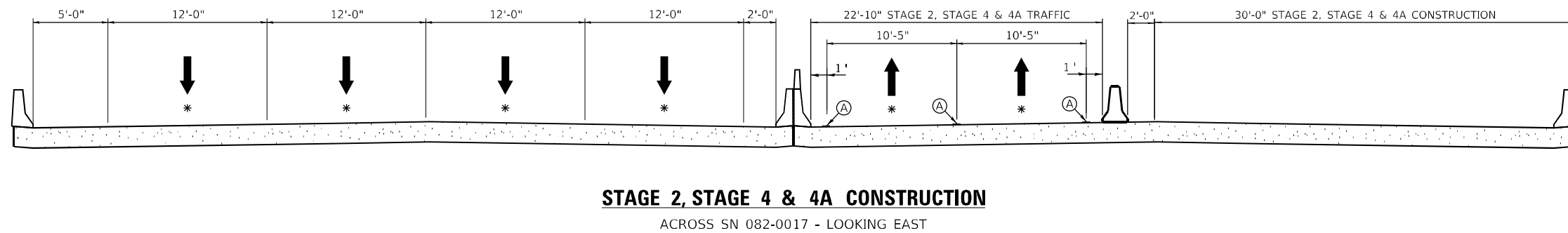
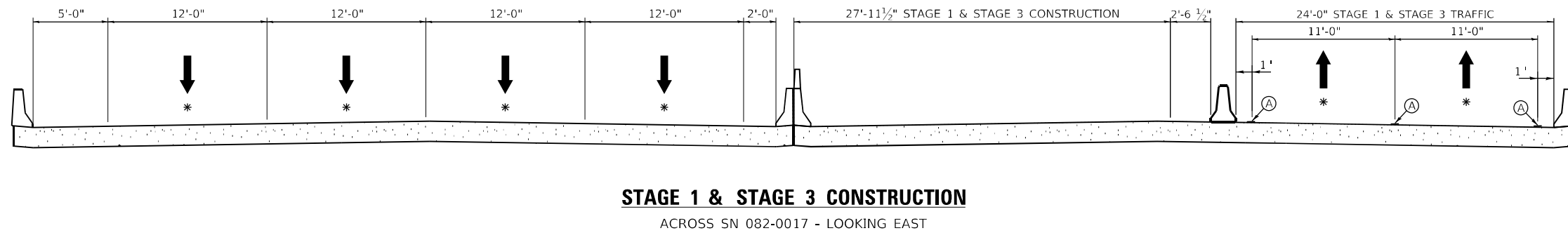
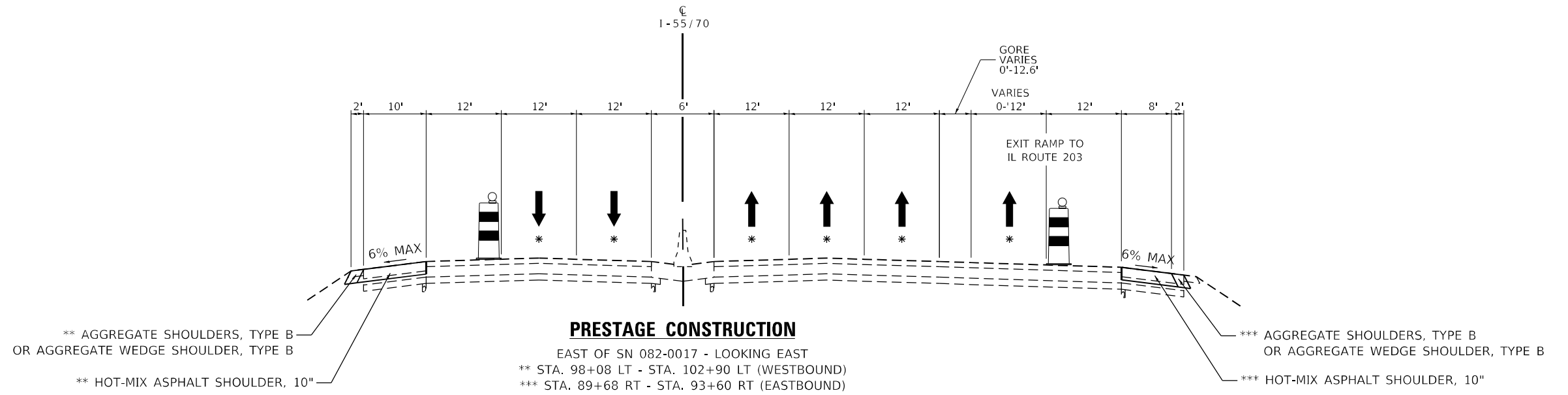

* DIRECTION OF TRAFFIC FLOW

(A) TEMPORARY PAVEMENT MARKING - LINE 6" - TYPE IV TAPE

MODEL: D:\efk\11
 FILE NAME: 211309229 B&O BR Bridge\DCN\Design\Final\B&O\Sheet35-36\082002-ctk.dwg, 02.dgn

EFK Moen
 Civil Engineering Design

USER NAME = zWaters	DESIGNED - SJF	REVISED -
	DRAWN - SJF	REVISED -
PLOT SCALE = 100,0000' / in.	CHECKED - SLD	REVISED -
PLOT DATE = 8/13/2024	DATE - 8/13/2024	REVISED -

**STATE OF ILLINOIS
 DEPARTMENT OF TRANSPORTATION**

**TRAFFIC CONTROL AND PROTECTION
 TYPICAL SECTIONS**

SCALE: N/A SHEET 2 OF 5>TFC SHEETS STA. TO STA.

F.A.I. RTE.	SECTION	COUNTY	TOTAL SHEETS	SHEET NO.
70	82-5V8-R-2	ST. CLAIR	254	36
CONTRACT NO. 76K02				
ILLINOIS FED. AID PROJECT				

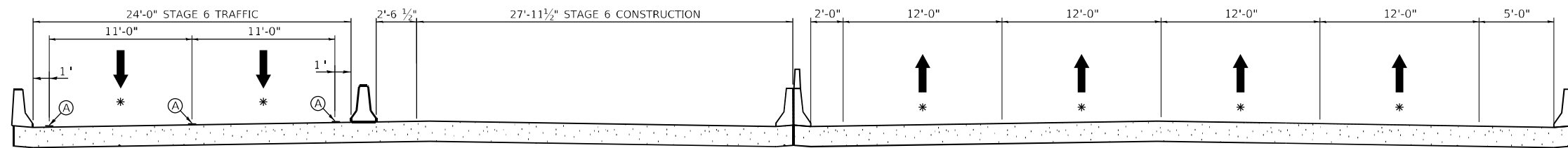

STAGE 6 CONSTRUCTION
ACROSS SN 082-0017 - LOOKING EAST

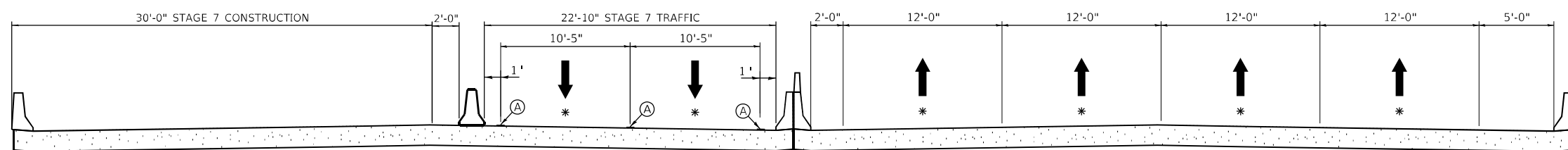

STAGE 7 CONSTRUCTION
ACROSS SN 082-0017 - LOOKING EAST

* DIRECTION OF TRAFFIC FLOW
 (A) TEMPORARY PAVEMENT MARKING - LINE 6" - TYPE IV TAPE

MODEL: D:\efc\h...
 FILE NAME: 2413093229 B&O BR Bridge\DCN\Design\Final\Figures\35-36\0820017-02-40g_02.dgn



USER NAME = zWaters	DESIGNED - SJF	REVISED -
	DRAWN - SJF	REVISED -
PLOT SCALE = 100,0000' / in.	CHECKED - SLD	REVISED -
PLOT DATE = 8/13/2024	DATE - 8/13/2024	REVISED -

**STATE OF ILLINOIS
DEPARTMENT OF TRANSPORTATION**

**TRAFFIC CONTROL AND PROTECTION
TYPICAL SECTIONS**

SCALE: N/A SHEET 3 OF 5>TFC SHEETS STA. TO STA.

F.A.I. RTE.	SECTION	COUNTY	TOTAL SHEETS	SHEET NO.
70	82-5V8-R-2	ST. CLAIR	254	37
CONTRACT NO. 76K02			ILLINOIS FED. AID PROJECT	

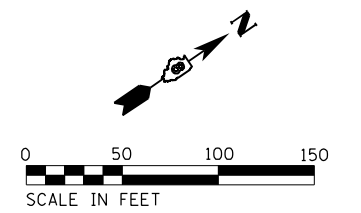
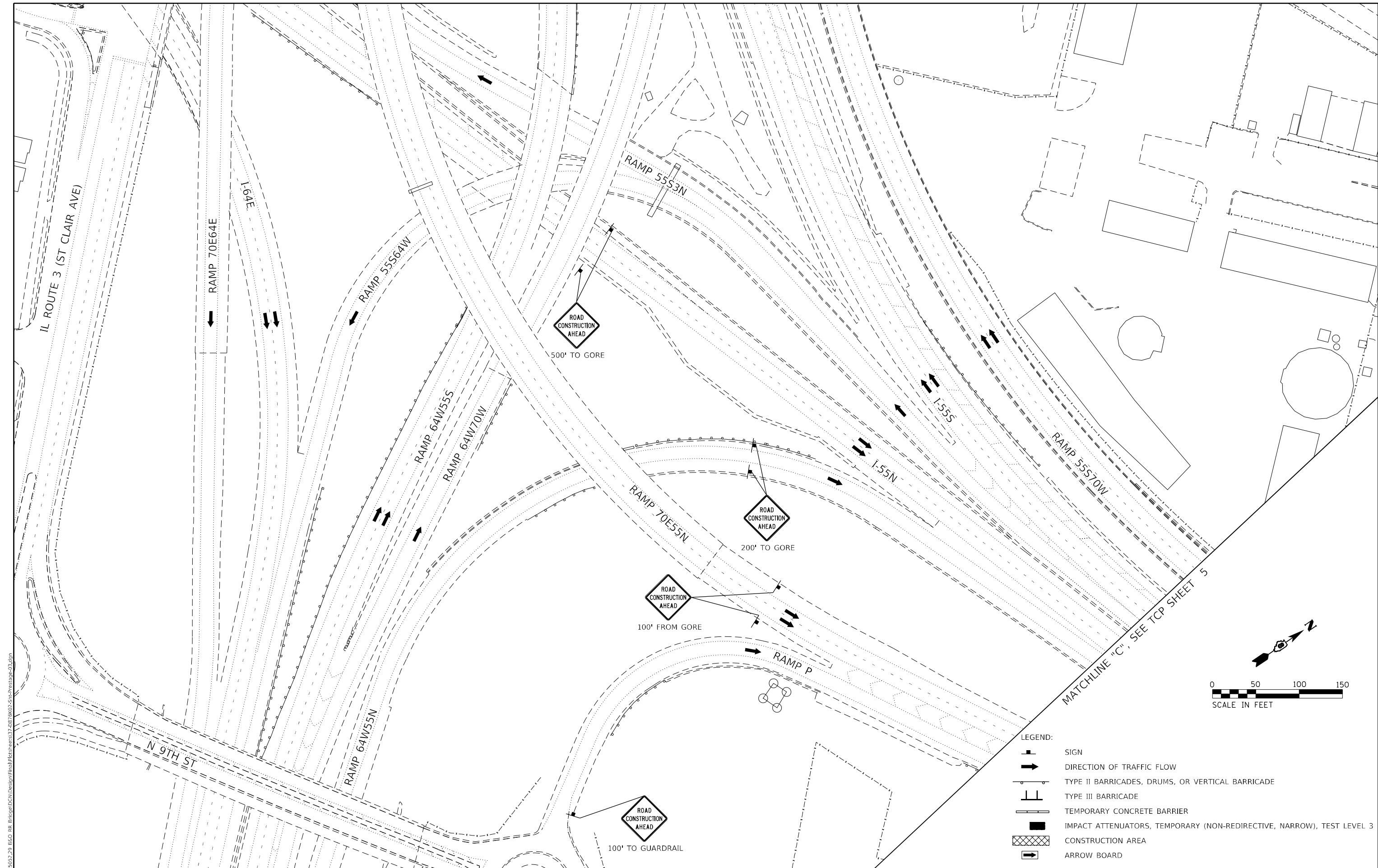

- LEGEND:**
- SIGN
 - DIRECTION OF TRAFFIC FLOW
 - TYPE II BARRICADES, DRUMS, OR VERTICAL BARRICADE
 - TYPE III BARRICADE
 - TEMPORARY CONCRETE BARRIER
 - IMPACT ATTENUATORS, TEMPORARY (NON-REDIRECTIVE, NARROW), TEST LEVEL 3
 - CONSTRUCTION AREA
 - ARROW BOARD

MODEL: 464641
 FILE NAME: Z:\13052229_BEGD_BR_Bridge\DCN\Design\Final\Final\Traffic\76K02-54-Prestage-03.dgn

EFK Moen
Civil Engineering Design

USER NAME = zWaters	DESIGNED - SJF	REVISED -
PLOT SCALE = 100,0000' / in.	DRAWN - SJF	REVISED -
PLOT DATE = 8/13/2024	CHECKED - SLD	REVISED -
	DATE - 8/13/2024	REVISED -

DESIGNED - SJF	REVISED -
DRAWN - SJF	REVISED -
CHECKED - SLD	REVISED -
DATE - 8/13/2024	REVISED -









**STATE OF ILLINOIS
DEPARTMENT OF TRANSPORTATION**

**TRAFFIC CONTROL AND PROTECTION PLAN
PRESTAGE**







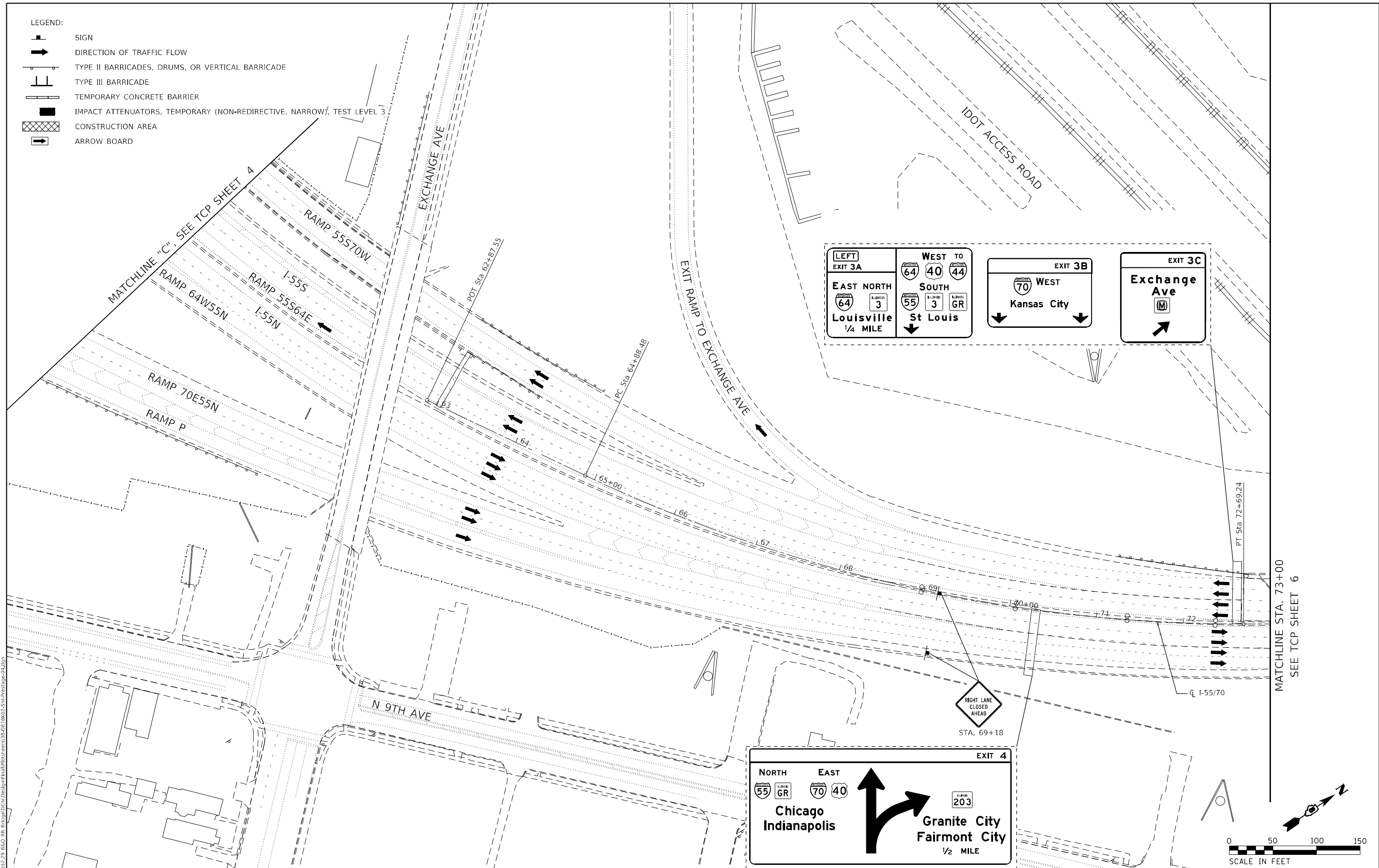

SCALE: 1"=50' SHEET 4 OF 5>TFC SHEETS STA. TO STA.





F.A.I. RTE.	SECTION	COUNTY	TOTAL SHEETS	SHEET NO.
70	82-5V8-R-2	ST. CLAIR	254	38
CONTRACT NO. 76K02				
ILLINOIS FED. AID PROJECT				

LEGEND:

-  SIGN
-  DIRECTION OF TRAFFIC FLOW
-  TYPE II BARRICADES, DRUMS, OR VERTICAL BARRICADE
-  TYPE III BARRICADE
-  TEMPORARY CONCRETE BARRIER
-  IMPACT ATTENUATORS, TEMPORARY (NON-REDIRECTIVE, NARROW), TEST LEVEL 3
-  CONSTRUCTION AREA
-  ARROW BOARD



LEFT EXIT 3A EAST NORTH  64 Louisville 1/4 MILE	WEST TO  64  40  44 SOUTH  55  3  GR St Louis	EXIT 3B  70 WEST Kansas City	EXIT 3C Exchange Ave 
---	--	---	--

NORTH  55  GR Chicago Indianapolis	EAST  70  40 Granite City Fairmont City 1/2 MILE
EXIT 4 	

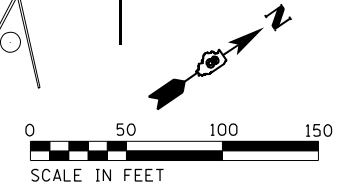

MODEL: 464611
 FILE NAME: Z:\13052239_BCO_BR_Bldg\DC\Design\Final\Bldg\Sheet39.DWG
 PROJECT: 13052239_BCO_BR_Bldg\DC\Design\Final\Bldg\Sheet39.DWG

EFK Moen
Civil Engineering Design









USER NAME = zWaters	DESIGNED - SJF	REVISED -
DRAWN - SJF	REVISIONS -	
PLOT SCALE = 100,0000' / in.	CHECKED - SLD	REVISED -
PLOT DATE = 8/13/2024	DATE - 8/13/2024	REVISED -

**STATE OF ILLINOIS
DEPARTMENT OF TRANSPORTATION**

**TRAFFIC CONTROL AND PROTECTION PLAN
PRESTAGE**

SCALE: 1"=50' SHEET 5 OF 5>TFC SHEETS STA. TO STA. 73+00

F.A.I. RTE.	SECTION	COUNTY	TOTAL SHEETS	SHEET NO.
70	82-5V8-R-2	ST. CLAIR	254	39
CONTRACT NO. 76K02				
ILLINOIS FED. AID PROJECT				

- LEGEND:
-  SIGN
 -  DIRECTION OF TRAFFIC FLOW
 -  TYPE II BARRICADES, DRUMS, OR VERTICAL BARRICADE
 -  TYPE III BARRICADE
 -  TEMPORARY CONCRETE BARRIER
 -  IMPACT ATTENUATORS, TEMPORARY (NON-REDIRECTIVE, NARROW), TEST LEVEL 3
 -  CONSTRUCTION AREA
 -  ARROW BOARD

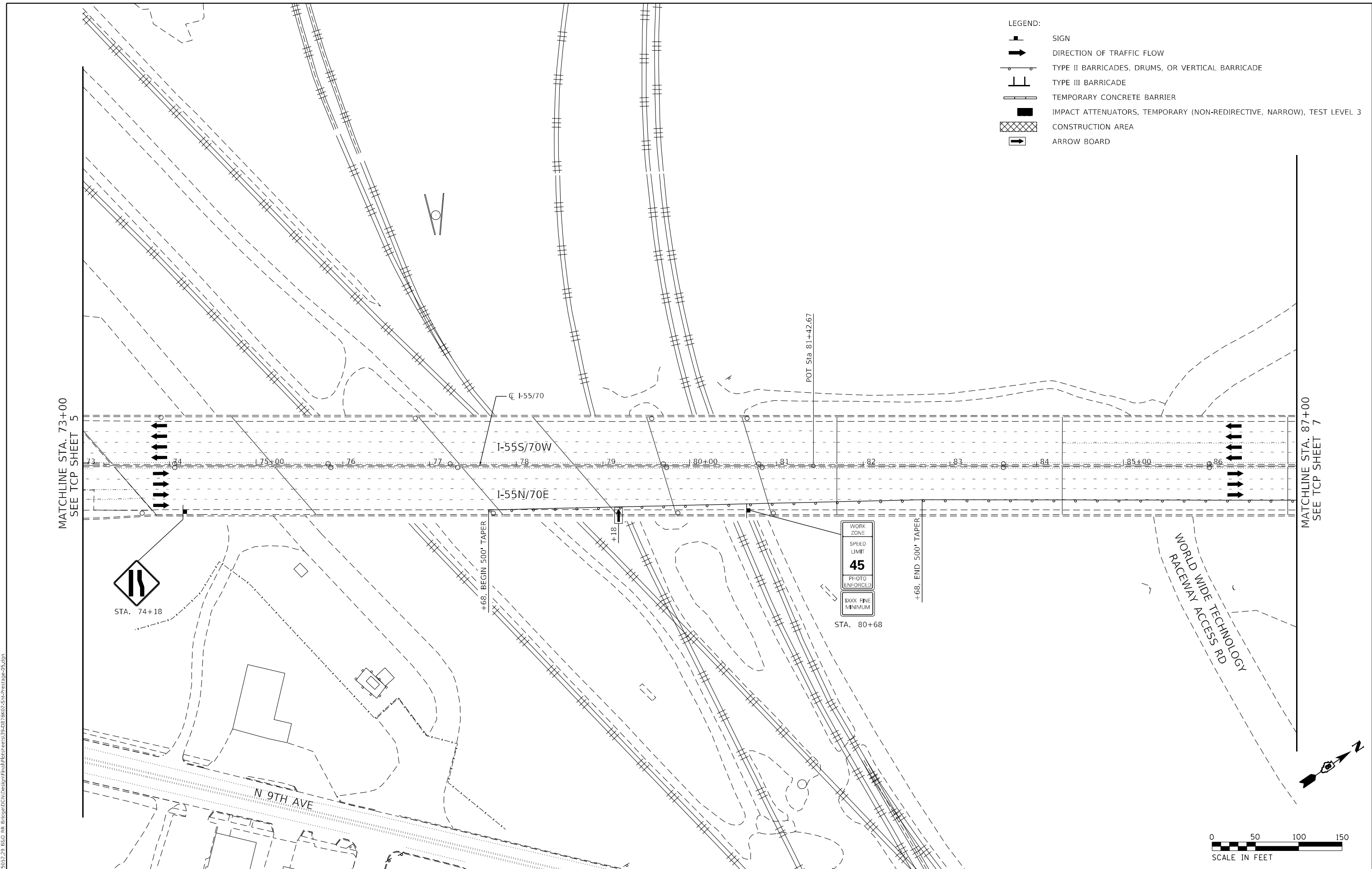

MODEL: 464611
 FILE NAME: Z:\13052229_B60_BR_Bridge\DC\Design\Final\Figures\3A\0876K02-Six-Prestage-05.dgn

EFK Moen
Civil Engineering Design

USER NAME = zWaters	DESIGNED - SJF	REVISED -
PLOT SCALE = 100,0000' / in.	DRAWN - SJF	REVISED -
PLOT DATE = 8/13/2024	CHECKED - SLD	REVISED -
	DATE - 8/13/2024	REVISED -









**STATE OF ILLINOIS
DEPARTMENT OF TRANSPORTATION**

**TRAFFIC CONTROL AND PROTECTION PLAN
PRESTAGE**

SCALE: 1"=50' SHEET 6 OF 5>TFC SHEETS STA. 73+00 TO STA. 87+00

F.A.I. RTE.	SECTION	COUNTY	TOTAL SHEETS	SHEET NO.
70	82-5V8-R-2	ST. CLAIR	254	40
CONTRACT NO. 76K02				
ILLINOIS FED. AID PROJECT				

LEGEND:

-  SIGN
-  DIRECTION OF TRAFFIC FLOW
-  TYPE II BARRICADES, DRUMS, OR VERTICAL BARRICADE
-  TYPE III BARRICADE
-  TEMPORARY CONCRETE BARRIER
-  IMPACT ATTENUATORS, TEMPORARY (NON-REDIRECTIVE, NARROW), TEST LEVEL 3
-  CONSTRUCTION AREA
-  ARROW BOARD

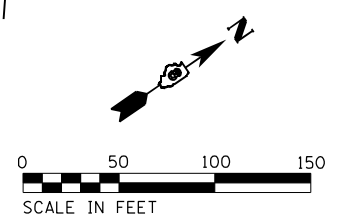
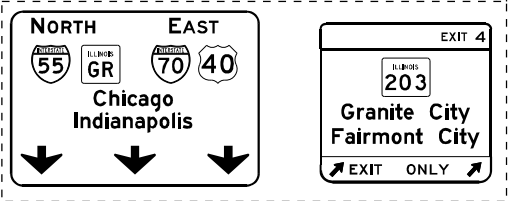
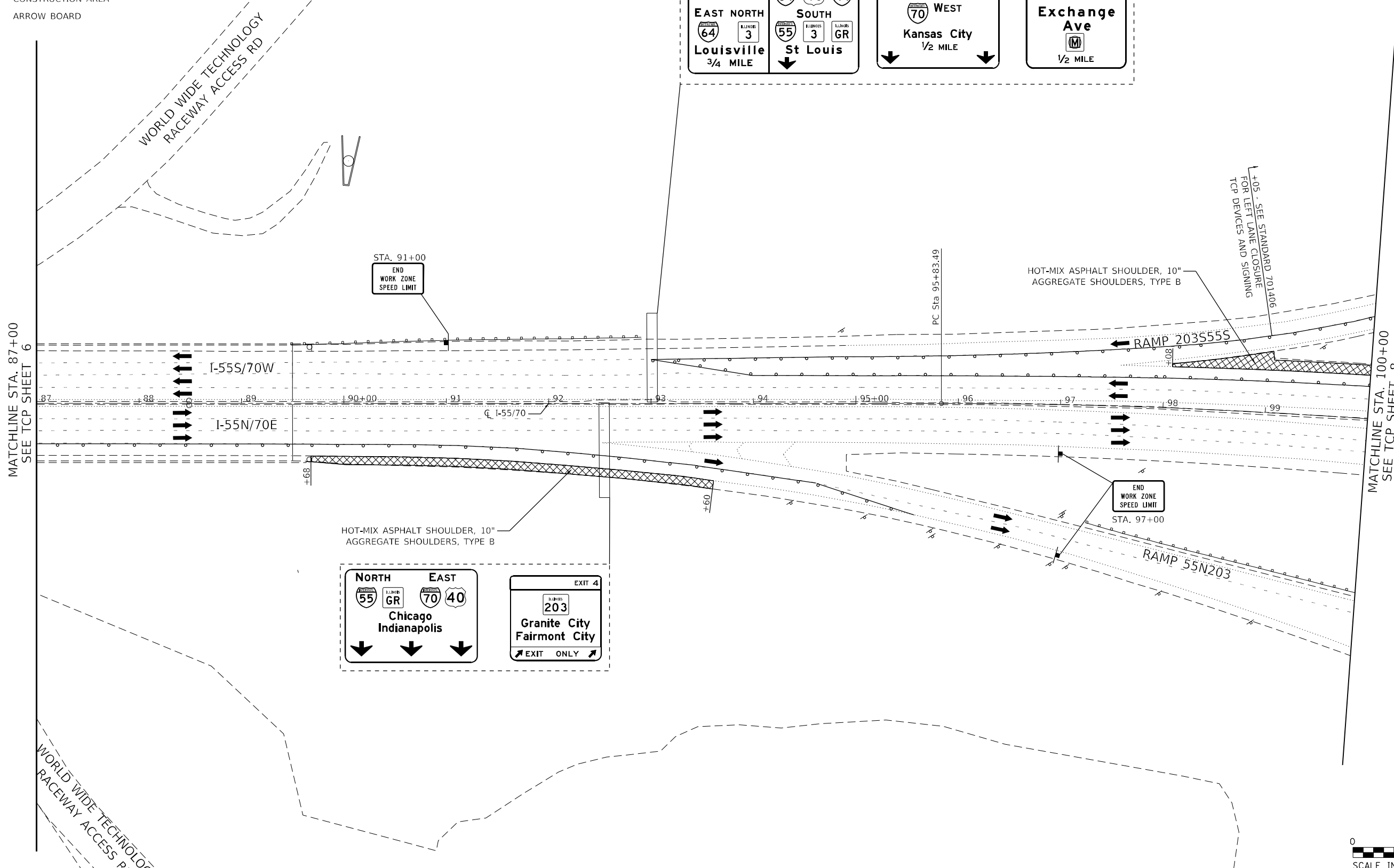
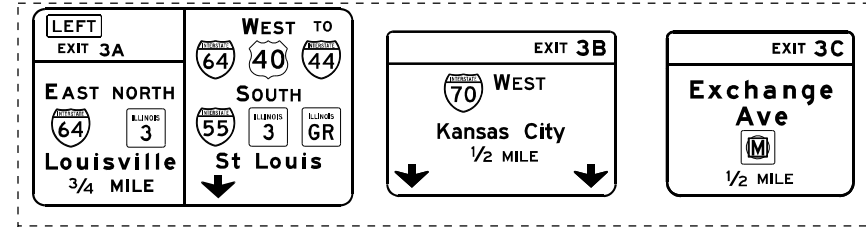

MODEL: 4646.dwg
 FILE NAME: Z:\130523-29_B&C_BR_Bridge\DCN\Design\Final\Final\Traffic\82-5V8-R-2\82-5V8-R-2-Prestage-06.dgn

EFK Moen
Civil Engineering Design

USER NAME = zWaters	DESIGNED - SJF	REVISED -
PLOT SCALE = 100,0000' / in.	DRAWN - SJF	REVISED -
PLOT DATE = 8/13/2024	CHECKED - SLD	REVISED -
	DATE - 8/13/2024	REVISED -









**STATE OF ILLINOIS
DEPARTMENT OF TRANSPORTATION**

**TRAFFIC CONTROL AND PROTECTION PLAN
PRESTAGE**

SCALE: 1"=50' SHEET 7 OF 5>TFC SHEETS STA. 87+00 TO STA. 100+00

F.A.I. RTE.	SECTION	COUNTY	TOTAL SHEETS	SHEET NO.
70	82-5V8-R-2	ST. CLAIR	254	41
CONTRACT NO. 76K02				
ILLINOIS FED. AID PROJECT				

LEGEND:

-  SIGN
-  DIRECTION OF TRAFFIC FLOW
-  TYPE II BARRICADES, DRUMS, OR VERTICAL BARRICADE
-  TYPE III BARRICADE
-  TEMPORARY CONCRETE BARRIER
-  IMPACT ATTENUATORS, TEMPORARY (NON-REDIRECTIVE, NARROW), TEST LEVEL 3
-  CONSTRUCTION AREA
-  ARROW BOARD

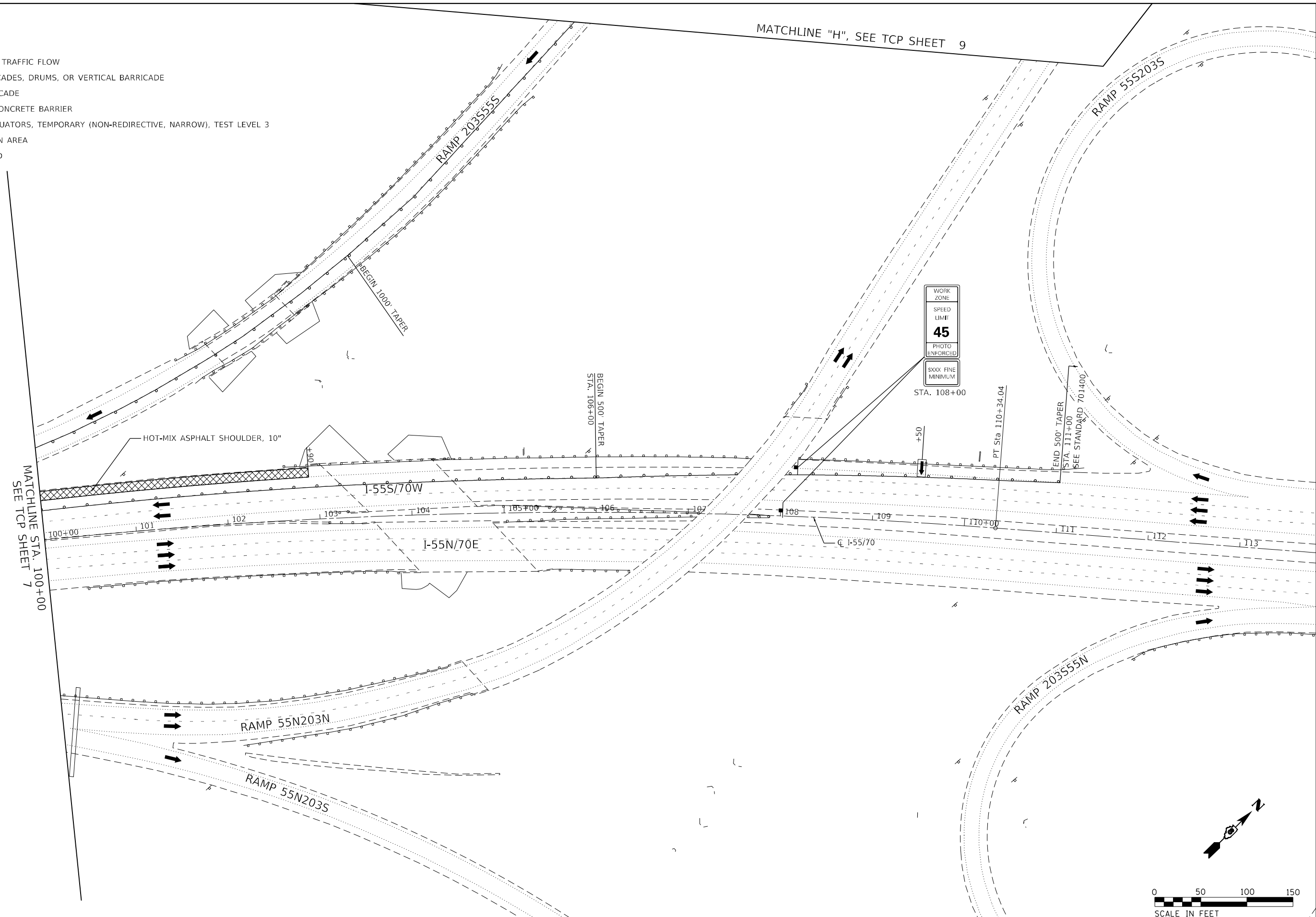

MODEL: 464641
 FILE NAME: Z:\130522\B60_BR_Bridge\DCN\Design\Final\B60-Prestage.dgn
 MODEL: 464641
 FILE NAME: Z:\130522\B60_BR_Bridge\DCN\Design\Final\B60-Prestage.dgn

EFK Moen
Civil Engineering Design

USER NAME = zWaters	DESIGNED - SJF	REVISED -
PLOT SCALE = 100,0000' / in.	DRAWN - SJF	REVISED -
PLOT DATE = 8/13/2024	CHECKED - SLD	REVISED -
	DATE - 8/13/2024	REVISED -

**STATE OF ILLINOIS
DEPARTMENT OF TRANSPORTATION**







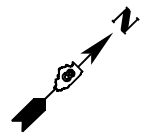
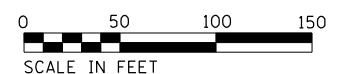

**TRAFFIC CONTROL AND PROTECTION PLAN
PRESTAGE**

SCALE: 1"=50' SHEET 8 OF 5>TFC SHEETS STA. 100+00 TO STA. 113+00

F.A.I. RTE.	SECTION	COUNTY	TOTAL SHEETS	SHEET NO.
70	82-5V8-R-2	ST. CLAIR	254	42
CONTRACT NO. 76K02				



LEGEND:

-  SIGN
-  DIRECTION OF TRAFFIC FLOW
-  TYPE II BARRICADES, DRUMS, OR VERTICAL BARRICADE
-  TYPE III BARRICADE
-  TEMPORARY CONCRETE BARRIER
-  IMPACT ATTENUATORS, TEMPORARY (NON-REDIRECTIVE, NARROW), TEST LEVEL 3
-  CONSTRUCTION AREA
-  ARROW BOARD

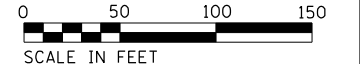
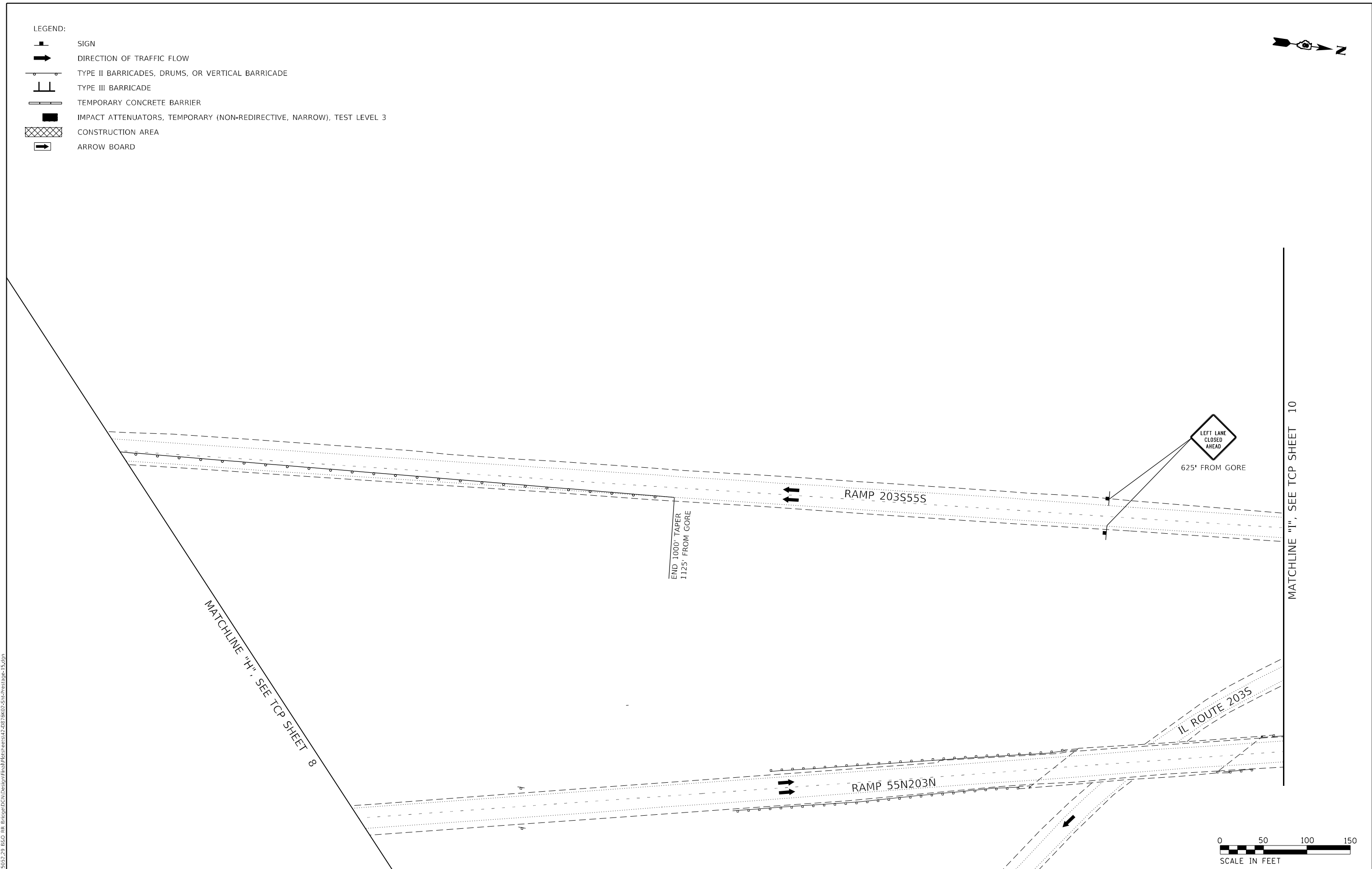

MODEL: d:\p\h
 FILE NAME: Z:\130522\BGO_BR_Bridge\DCN\Design\Final\Final\Sheet\13-0876K02-Site-Prestage-15.dgn

EFK Moen
Civil Engineering Design

USER NAME = zWaters	DESIGNED - SJF	REVISED -
PLOT SCALE = 100,0000 ' / in.	DRAWN - SJF	REVISED -
PLOT DATE = 8/13/2024	CHECKED - SLD	REVISED -
	DATE - 8/13/2024	REVISED -

DESIGNED - SJF	REVISED -
DRAWN - SJF	REVISED -
CHECKED - SLD	REVISED -
DATE - 8/13/2024	REVISED -









**STATE OF ILLINOIS
DEPARTMENT OF TRANSPORTATION**

**TRAFFIC CONTROL AND PROTECTION PLAN
PRESTAGE**

SCALE: 1"=50' SHEET 9 OF 5>TFC SHEETS STA. TO STA.

F.A.I. RTE.	SECTION	COUNTY	TOTAL SHEETS	SHEET NO.
70	82-5V8-R-2	ST. CLAIR	254	43
CONTRACT NO. 76K02				
ILLINOIS FED. AID PROJECT				

LEGEND:

-  SIGN
-  DIRECTION OF TRAFFIC FLOW
-  TYPE II BARRICADES, DRUMS, OR VERTICAL BARRICADE
-  TYPE III BARRICADE
-  TEMPORARY CONCRETE BARRIER
-  IMPACT ATTENUATORS, TEMPORARY (NON-REDIRECTIVE, NARROW), TEST LEVEL 3
-  CONSTRUCTION AREA
-  ARROW BOARD

MATCHLINE "I", SEE TCP SHEET 9

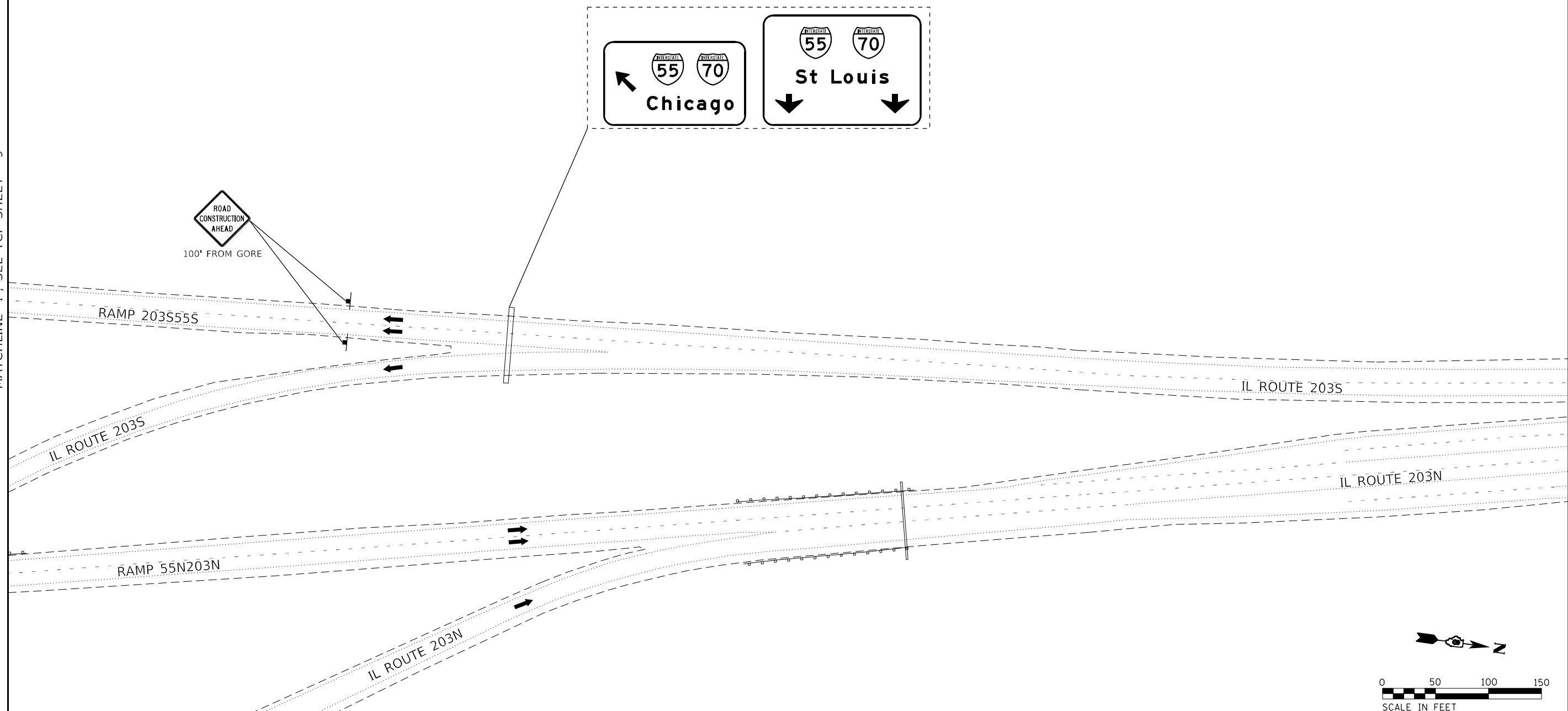

MODEL: 464646
FILE NAME: Z:\1305229 B&O BR Bridge\DCN\Design\Final\Bldg\Sheet13-076K02-Sub-Prestage-16.dgn

EFK Moen
Civil Engineering Design

USER NAME = zWaters	DESIGNED - SJF	REVISED -
PLOT SCALE = 100,0000' / in.	DRAWN - SJF	REVISED -
PLOT DATE = 8/13/2024	CHECKED - SLD	REVISED -
	DATE - 8/13/2024	REVISED -

**STATE OF ILLINOIS
DEPARTMENT OF TRANSPORTATION**

**TRAFFIC CONTROL AND PROTECTION PLAN
PRESTAGE**

SCALE: 1"=50' SHEET 10 OF 5>TFC SHEETS STA. TO STA.

F.A.I. RTE.	SECTION	COUNTY	TOTAL SHEETS	SHEET NO.
70	82-5V8-R-2	ST. CLAIR	254	44
CONTRACT NO. 76K02				
ILLINOIS FED. AID PROJECT				

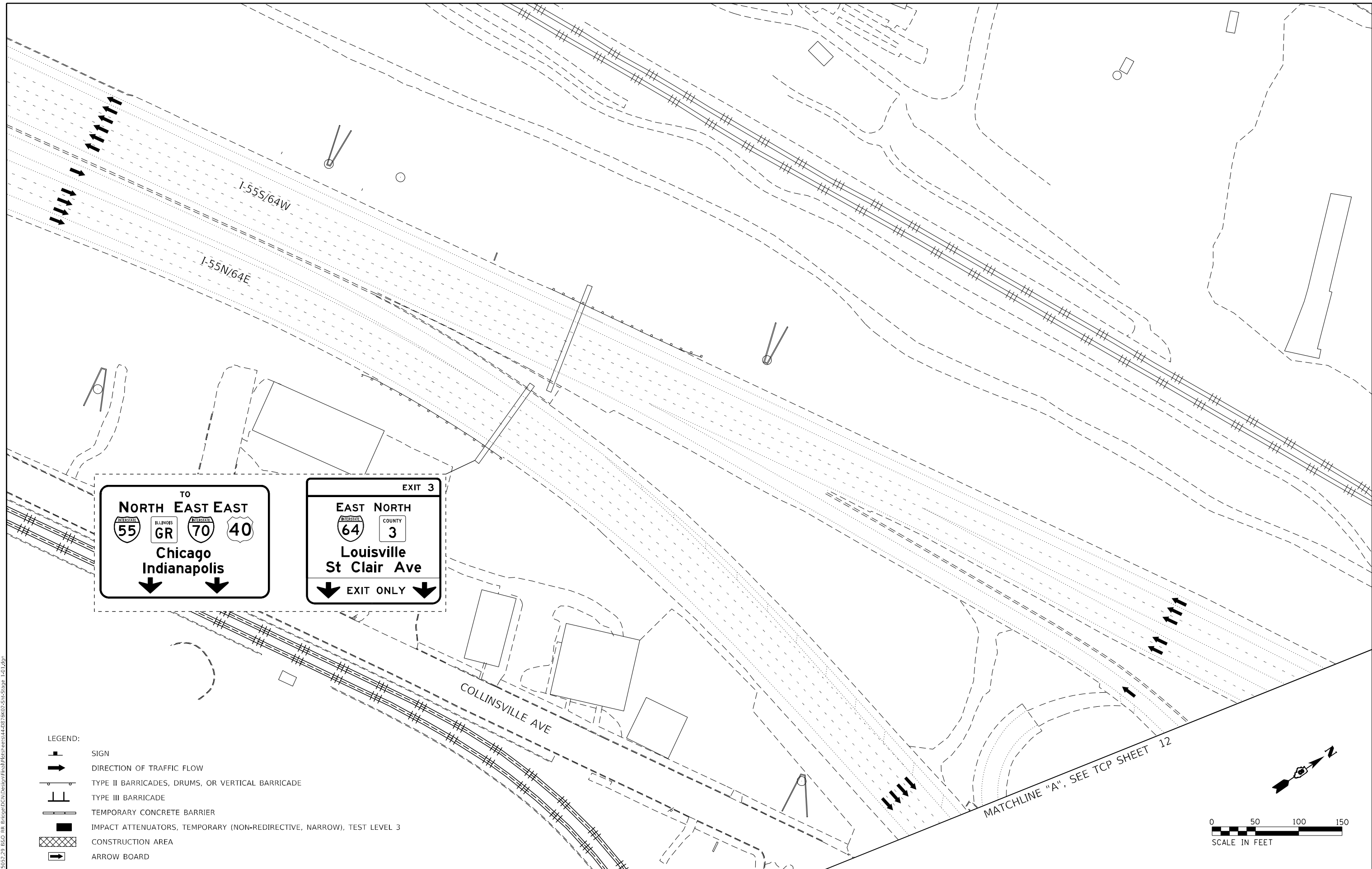

TO
NORTH EAST EAST
 ILLINOIS STATE ROUTE 55 GR ILLINOIS STATE ROUTE 70 40
Chicago Indianapolis

EXIT 3
 EAST NORTH
 ILLINOIS STATE ROUTE 64 COUNTY 3
Louisville St Clair Ave
 EXIT ONLY

- LEGEND:
- SIGN
 - DIRECTION OF TRAFFIC FLOW
 - TYPE II BARRICADES, DRUMS, OR VERTICAL BARRICADE
 - TYPE III BARRICADE
 - TEMPORARY CONCRETE BARRIER
 - IMPACT ATTENUATORS, TEMPORARY (NON-REDIRECTIVE, NARROW), TEST LEVEL 3
 - CONSTRUCTION AREA
 - ARROW BOARD

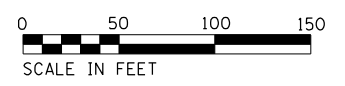

MODEL: 464611
 FILE NAME: Z:\1305229_B60_BR_Bridge\DCN\Design\Final\TFC\Sheet14.DWG
 USER: zlwaters
 DATE: 8/13/2024

EFK Moen
 Civil Engineering Design

USER NAME = zlwaters	DESIGNED - SJF	REVISED -
PLOT SCALE = 100,0000' / in.	DRAWN - SJF	REVISED -
PLOT DATE = 8/13/2024	CHECKED - SLD	REVISED -
	DATE - 8/13/2024	REVISED -

**STATE OF ILLINOIS
 DEPARTMENT OF TRANSPORTATION**









**TRAFFIC CONTROL AND PROTECTION PLAN
 STAGE 1**

SCALE: 1"=50' SHEET 11 OF 5>TFC SHEETS STA. TO STA.

F.A.I. RTE.	SECTION	COUNTY	TOTAL SHEETS	SHEET NO.
70	82-5V8-R-2	ST. CLAIR	254	45
CONTRACT NO. 76K02				

ILLINOIS FED. AID PROJECT

LEGEND:

-  SIGN
-  DIRECTION OF TRAFFIC FLOW
-  TYPE II BARRICADES, DRUMS, OR VERTICAL BARRICADE
-  TYPE III BARRICADE
-  TEMPORARY CONCRETE BARRIER
-  IMPACT ATTENUATORS, TEMPORARY (NON-REDIRECTIVE, NARROW), TEST LEVEL 3
-  CONSTRUCTION AREA
-  ARROW BOARD

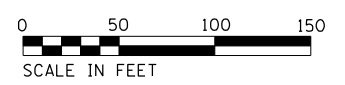
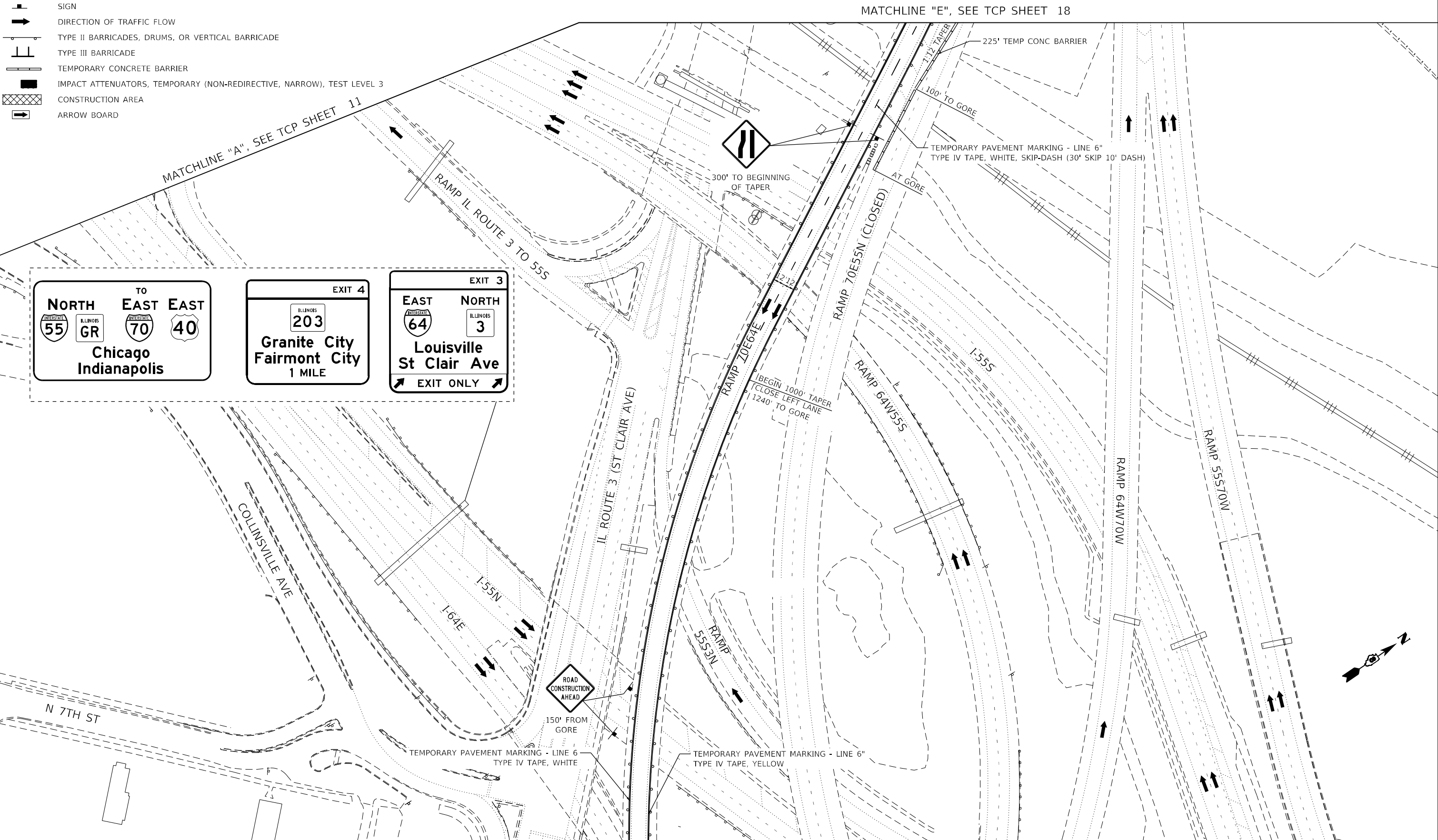

MODEL: 464611
 FILE NAME: Z:\2023\23_BCO_BR_Bldg\DC\Design\Final\Refer\23_0876K02_Sht-Stage_1.dwg

EFK Moen
Civil Engineering Design

USER NAME = zWaters	DESIGNED - SJF	REVISED -
PLOT SCALE = 100,000' / in.	DRAWN - SJF	REVISED -
PLOT DATE = 8/13/2024	CHECKED - SLD	REVISED -
	DATE - 8/13/2024	REVISED -

STATE OF ILLINOIS
DEPARTMENT OF TRANSPORTATION

TRAFFIC CONTROL AND PROTECTION PLAN
STAGE 1

SCALE: 1"=50' SHEET 12 OF 5>TFC SHEETS STA. TO STA.

F.A.I. RTE.	SECTION	COUNTY	TOTAL SHEETS	SHEET NO.
70	82-5V8-R-2	ST. CLAIR	254	46
CONTRACT NO. 76K02				
ILLINOIS FED. AID PROJECT				

MATCHLINE "B", SEE TCP SHEET 12

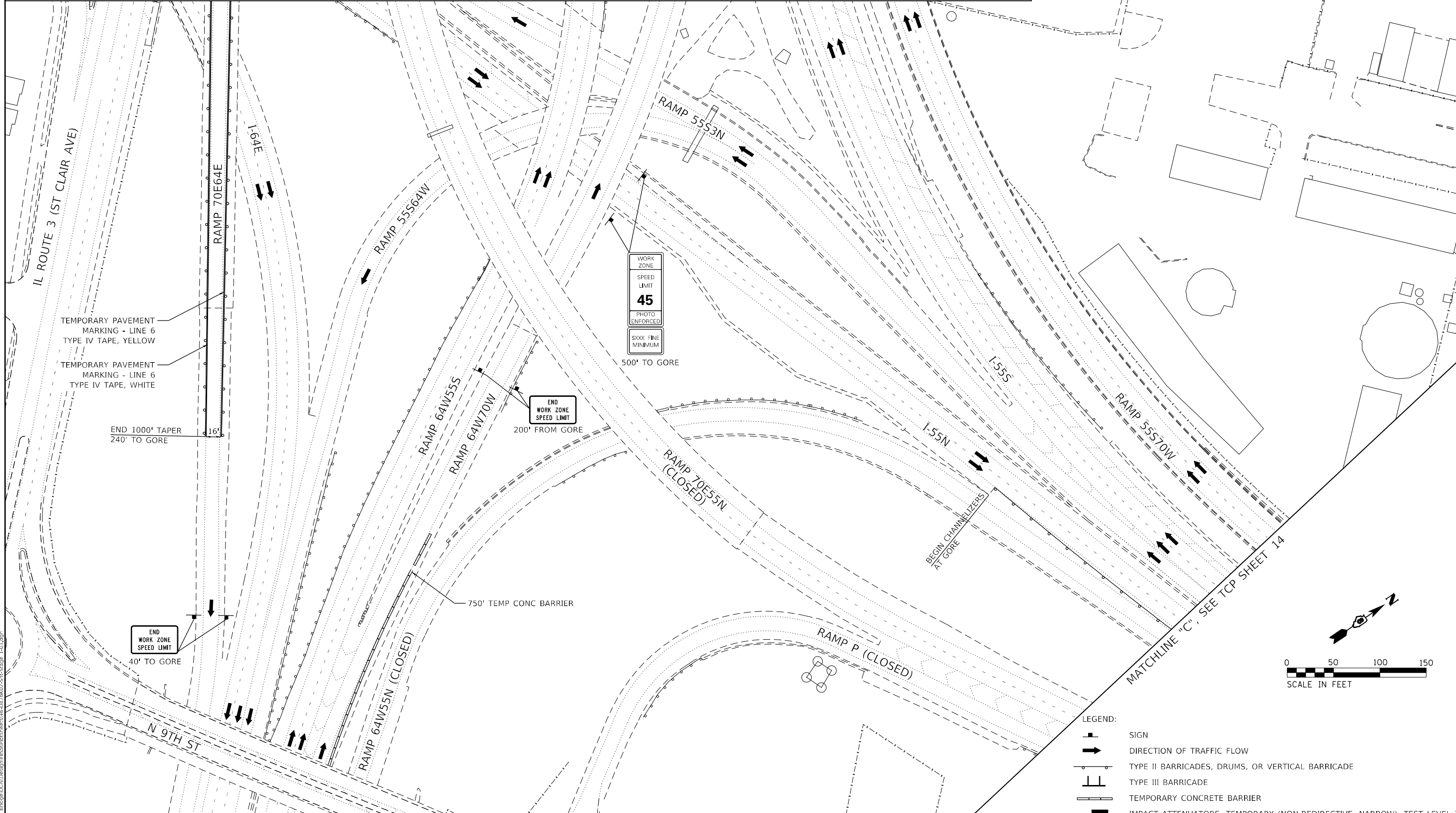

MATCHLINE "F", SEE TCP SHEET 19

- LEGEND:
- SIGN
 - DIRECTION OF TRAFFIC FLOW
 - TYPE II BARRICADES, DRUMS, OR VERTICAL BARRICADE
 - TYPE III BARRICADE
 - TEMPORARY CONCRETE BARRIER
 - IMPACT ATTENUATORS, TEMPORARY (NON-REDIRECTIVE, NARROW), TEST LEVEL 3
 - CONSTRUCTION AREA
 - ARROW BOARD

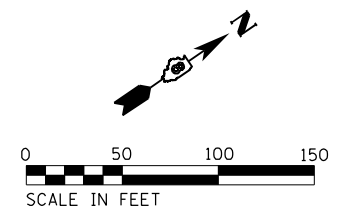

MODEL: 4646.dwg
 FILE NAME: Z:\13052.29 B60, B8, B66ge\DC\DC\Design\Plan\Traffic\82-5V8-R-2\82-5V8-R-2-Stage 1.dwg

EFK Moen
Civil Engineering Design

USER NAME = zWaters	DESIGNED - SJF	REVISED -
PLOT SCALE = 100,0000' / in.	DRAWN - SJF	REVISED -
PLOT DATE = 8/13/2024	CHECKED - SLD	REVISED -
	DATE - 8/13/2024	REVISED -

**STATE OF ILLINOIS
DEPARTMENT OF TRANSPORTATION**

**TRAFFIC CONTROL AND PROTECTION PLAN
STAGE 1**

SCALE: 1"=50' SHEET 13 OF 5>TFC SHEETS STA. TO STA.

F.A.I. RTE.	SECTION	COUNTY	TOTAL SHEETS	SHEET NO.
70	82-5V8-R-2	ST. CLAIR	254	47
CONTRACT NO. 76K02				
ILLINOIS FED. AID PROJECT				

- LEGEND:
- SIGN
 - DIRECTION OF TRAFFIC FLOW
 - TYPE II BARRICADES, DRUMS, OR VERTICAL BARRICADE
 - TYPE III BARRICADE
 - TEMPORARY CONCRETE BARRIER
 - IMPACT ATTENUATORS, TEMPORARY (NON-REDIRECTIVE, NARROW), TEST LEVEL 3
 - CONSTRUCTION AREA
 - ARROW BOARD

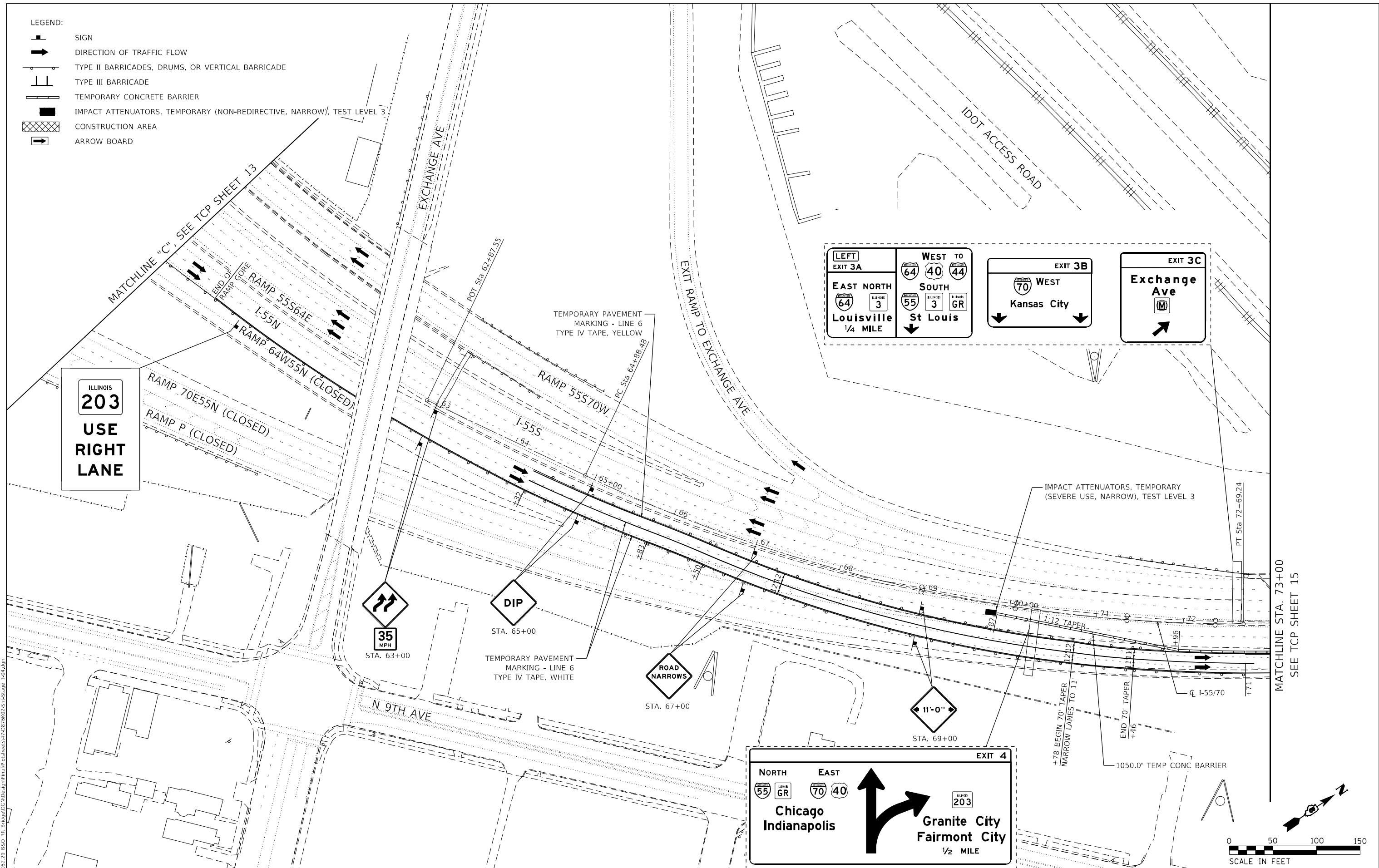

LEFT EXIT 3A	WEST TO 64 40 44	EXIT 3B	EXIT 3C
EAST NORTH 64 3	SOUTH 55 3 GR	WEST 70 Kansas City	Exchange Ave M
Louisville 1/4 MILE	St Louis		

NORTH 55 GR	EAST 70 40	EXIT 4
Chicago Indianapolis		Granite City Fairmont City 1/2 MILE

MATCHLINE STA. 73+00
SEE TCP SHEET 15

MODEL: 464641
 FILE NAME: Z:\13052239_B60_BR_B6464641\Design\Plan\Traffic\Stage 1\04.dwg
 USER: zWaters

EFK Moen
Civil Engineering Design









USER NAME = zWaters	DESIGNED - SJF	REVISED -
PLOT SCALE = 100,0000' / in.	DRAWN - SJF	REVISED -
PLOT DATE = 8/13/2024	CHECKED - SLD	REVISED -
	DATE - 8/13/2024	REVISED -

STATE OF ILLINOIS
DEPARTMENT OF TRANSPORTATION

TRAFFIC CONTROL AND PROTECTION PLAN
STAGE 1

SCALE: 1"=50' SHEET 14 OF 5>TFC SHEETS STA. TO STA. 73+00

F.A.I. RTE.	SECTION	COUNTY	TOTAL SHEETS	SHEET NO.
70	82-5V8-R-2	ST. CLAIR	254	48
CONTRACT NO. 76K02				
ILLINOIS FED. AID PROJECT				

- LEGEND:
-  SIGN
 -  DIRECTION OF TRAFFIC FLOW
 -  TYPE II BARRICADES, DRUMS, OR VERTICAL BARRICADE
 -  TYPE III BARRICADE
 -  TEMPORARY CONCRETE BARRIER
 -  IMPACT ATTENUATORS, TEMPORARY (NON-REDIRECTIVE, NARROW), TEST LEVEL 3
 -  CONSTRUCTION AREA
 -  ARROW BOARD

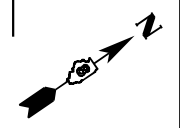
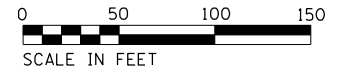
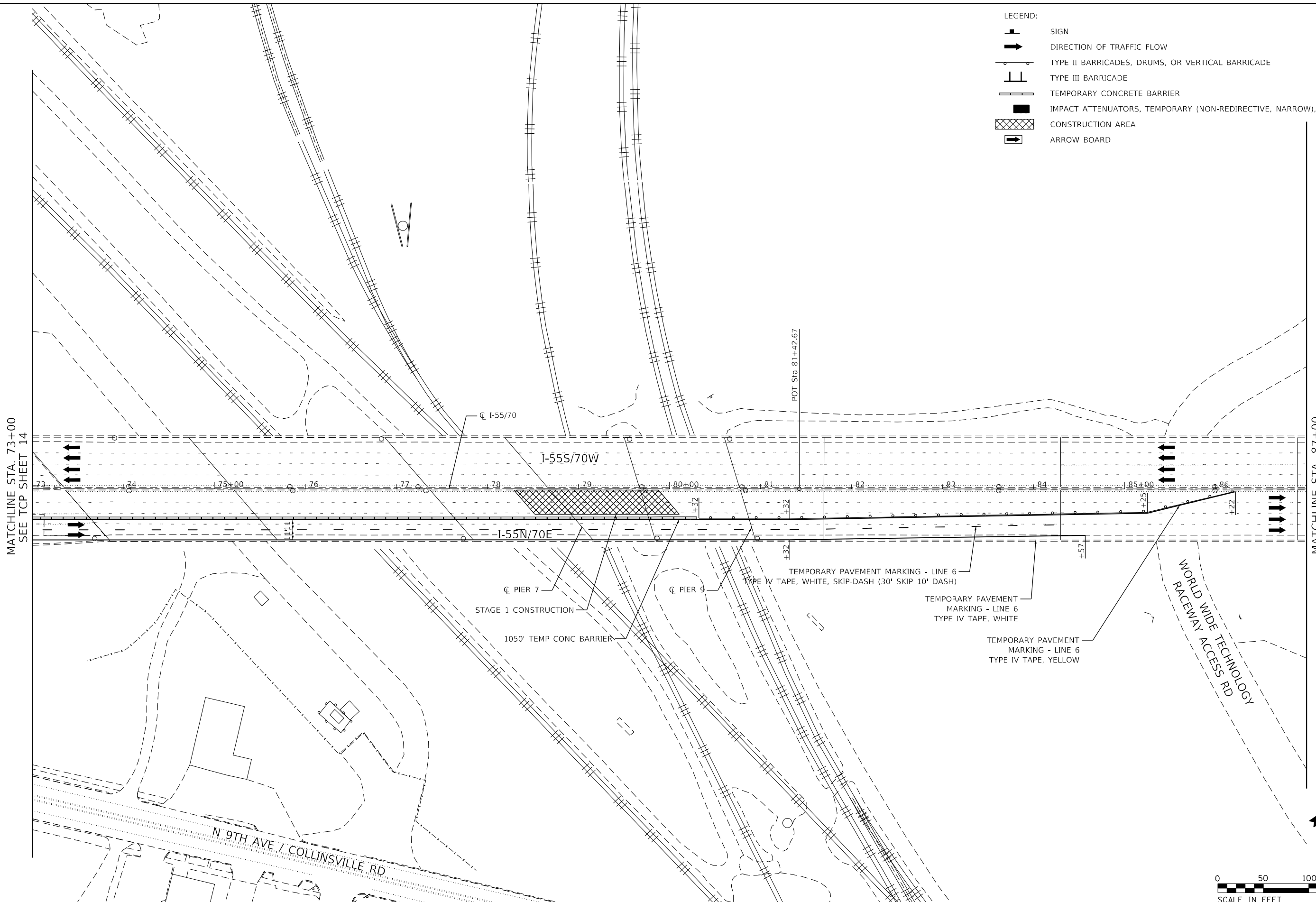

MODEL: 4646.dwg
 FILE NAME: Z:\13052-29_B60_BR_Bridge\DC\Design\Plan\Traffic\Sheet14-0876K02-Sub-Stage_1.dwg

EFK Moen
Civil Engineering Design

USER NAME = zWaters	DESIGNED - SJF	REVISED -
PLOT SCALE = 100,0000' / in.	DRAWN - SJF	REVISED -
PLOT DATE = 8/13/2024	CHECKED - SLD	REVISED -
	DATE - 8/13/2024	REVISED -









**STATE OF ILLINOIS
DEPARTMENT OF TRANSPORTATION**







**TRAFFIC CONTROL AND PROTECTION PLAN
STAGE 1**





SCALE: 1"=50' SHEET 15 OF 5>TFC SHEETS STA. 73+00 TO STA. 87+00

F.A.I. RTE.	SECTION	COUNTY	TOTAL SHEETS	SHEET NO.
70	82-5V8-R-2	ST. CLAIR	254	49
CONTRACT NO. 76K02				
ILLINOIS FED. AID PROJECT				

LEGEND:

-  SIGN
-  DIRECTION OF TRAFFIC FLOW
-  TYPE II BARRICADES, DRUMS, OR VERTICAL BARRICADE
-  TYPE III BARRICADE
-  TEMPORARY CONCRETE BARRIER
-  IMPACT ATTENUATORS, TEMPORARY (NON-REDIRECTIVE, NARROW), TEST LEVEL 3
-  CONSTRUCTION AREA
-  ARROW BOARD

LEFT EXIT 3A EAST NORTH  64 Louisville 3/4 MILE	WEST TO  64  40  44 SOUTH  55 St Louis 3/4 MILE	EXIT 3B  70 WEST Kansas City 1/2 MILE	EXIT 3C Exchange Ave  M 1/2 MILE
--	---	---	--

NORTH  55 Chicago Indianapolis	EAST  70  40 Granite City Fairmont City
EXIT 4  203 Granite City Fairmont City EXIT ONLY	

MATCHLINE STA. 87+00
SEE TCP SHEET 15

WORLD WIDE TECHNOLOGY
RACEWAY ACCESS RD

WORLD WIDE TECHNOLOGY
RACEWAY ACCESS RD

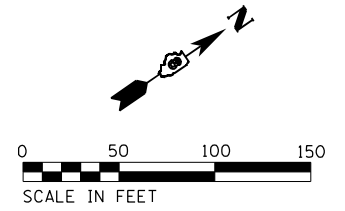
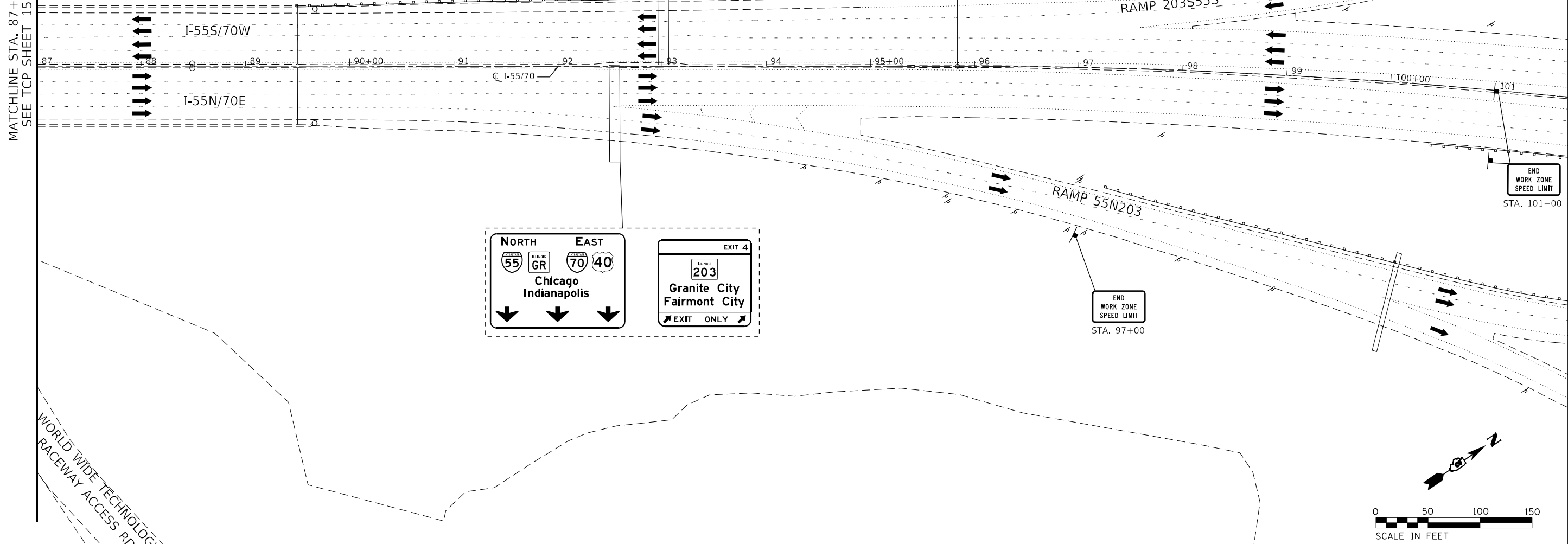

MODEL: d464h
FILE NAME: Z:\2024\29_BCO_BR_Bridge\DCN\Design\Final\Fetch\Sheet\82-5V8-R-2-Stage_1.dwg

EFK Moen
Civil Engineering Design

USER NAME = zWaters	DESIGNED - SJF	REVISED -
PLOT SCALE = 100,0000' / in.	DRAWN - SJF	REVISED -
PLOT DATE = 8/13/2024	CHECKED - SLD	REVISED -
	DATE - 8/13/2024	REVISED -

**STATE OF ILLINOIS
DEPARTMENT OF TRANSPORTATION**

**TRAFFIC CONTROL AND PROTECTION PLAN
STAGE 1**

SCALE: 1"=50' SHEET 16 OF 5>TFC SHEETS STA. 87+00 TO STA. 100+00

F.A.I. RTE.	SECTION	COUNTY	TOTAL SHEETS	SHEET NO.
70	82-5V8-R-2	ST. CLAIR	254	50
CONTRACT NO. 76K02				
ILLINOIS FED. AID PROJECT				

ADVANCED SIGNING ALONG I-70 (WESTBOUND)

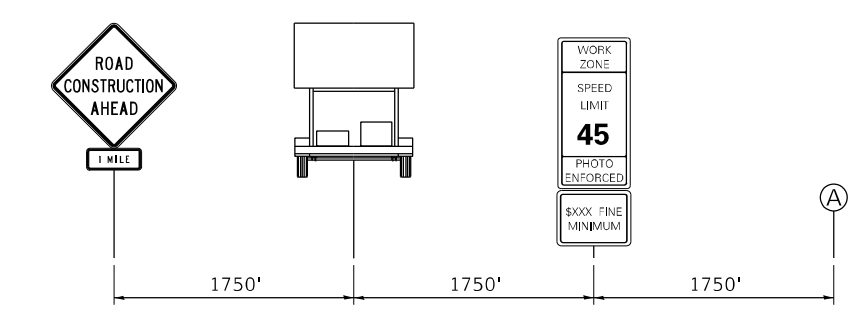

NOTE:
1. ADVANCED WARNING SIGNS SHALL BE PLACED ON EITHER SIDE OF WESTBOUND I-70.

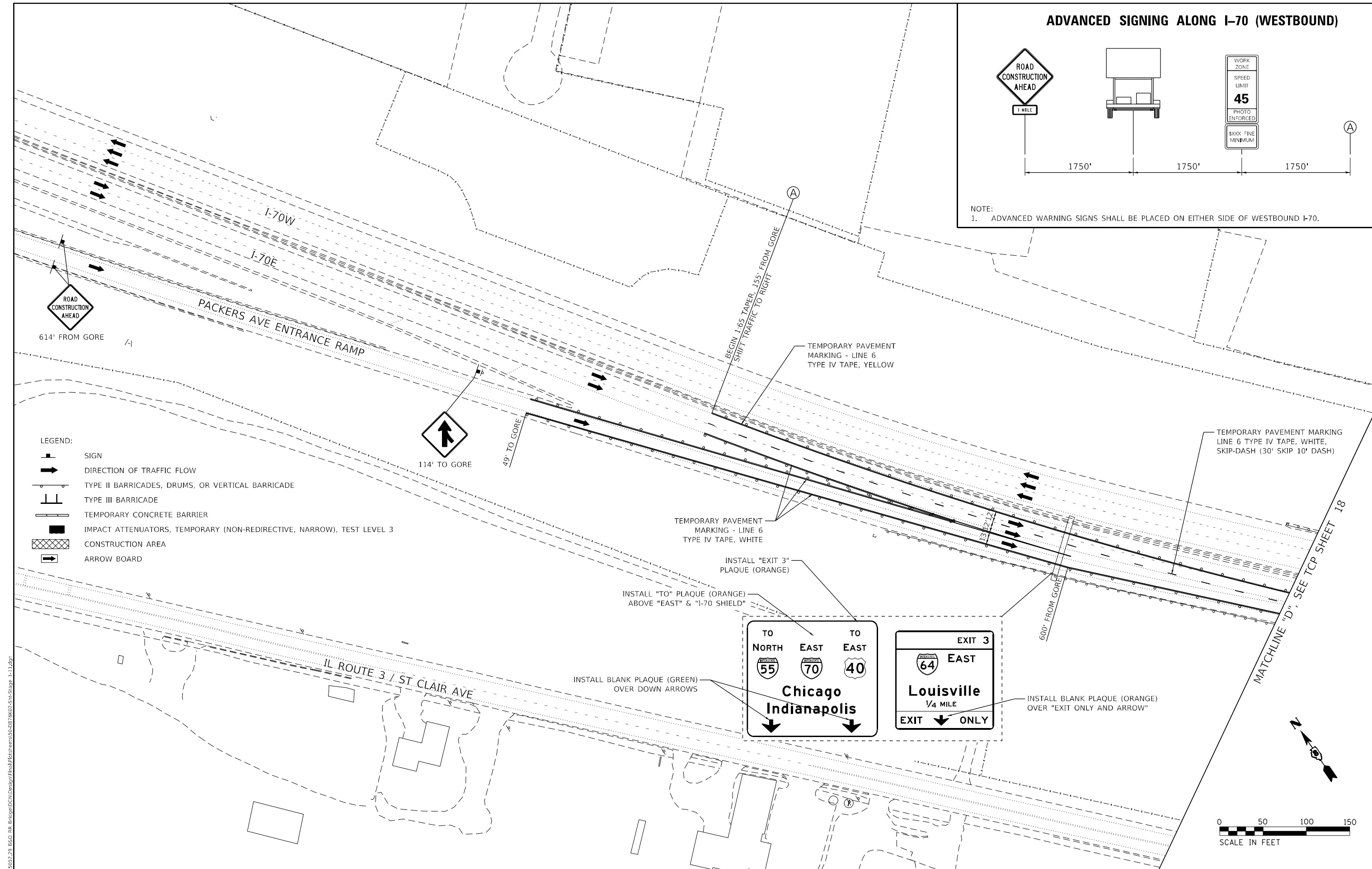

- LEGEND:**
- SIGN
 - DIRECTION OF TRAFFIC FLOW
 - TYPE II BARRICADES, DRUMS, OR VERTICAL BARRICADE
 - TYPE III BARRICADE
 - TEMPORARY CONCRETE BARRIER
 - IMPACT ATTENUATORS, TEMPORARY (NON-REDIRECTIVE, NARROW), TEST LEVEL 3
 - CONSTRUCTION AREA
 - ARROW BOARD

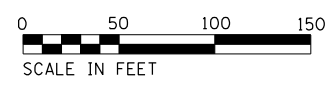
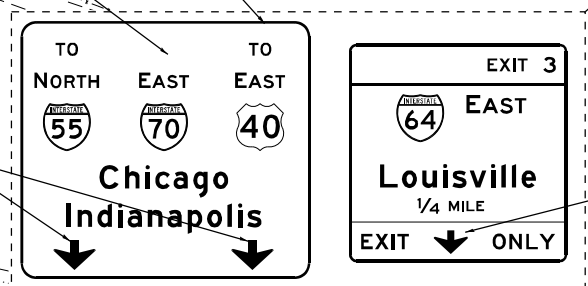

MODEL: 464611
 FILE NAME: Z:\2023\23_B60_BR_Bridge\DCN\Design\Final\Final\Sheet\50-076K02-Sub-Stage 1-1.dgn
 DATE: 8/13/2024

EFK Moen
Civil Engineering Design

USER NAME = zWaters	DESIGNED - SJF	REVISED -
PLOT SCALE = 100,0000' / in.	DRAWN - SJF	REVISED -
PLOT DATE = 8/13/2024	CHECKED - SLD	REVISED -
	DATE - 8/13/2024	REVISED -

**STATE OF ILLINOIS
DEPARTMENT OF TRANSPORTATION**

**TRAFFIC CONTROL AND PROTECTION PLAN
STAGE 1**

SCALE: 1"=50' SHEET 17 OF 5>TFC SHEETS STA. TO STA.

F.A.I. RTE.	SECTION	COUNTY	TOTAL SHEETS	SHEET NO.
70	82-5V8-R-2	ST. CLAIR	254	51
CONTRACT NO. 76K02			ILLINOIS FED. AID PROJECT	

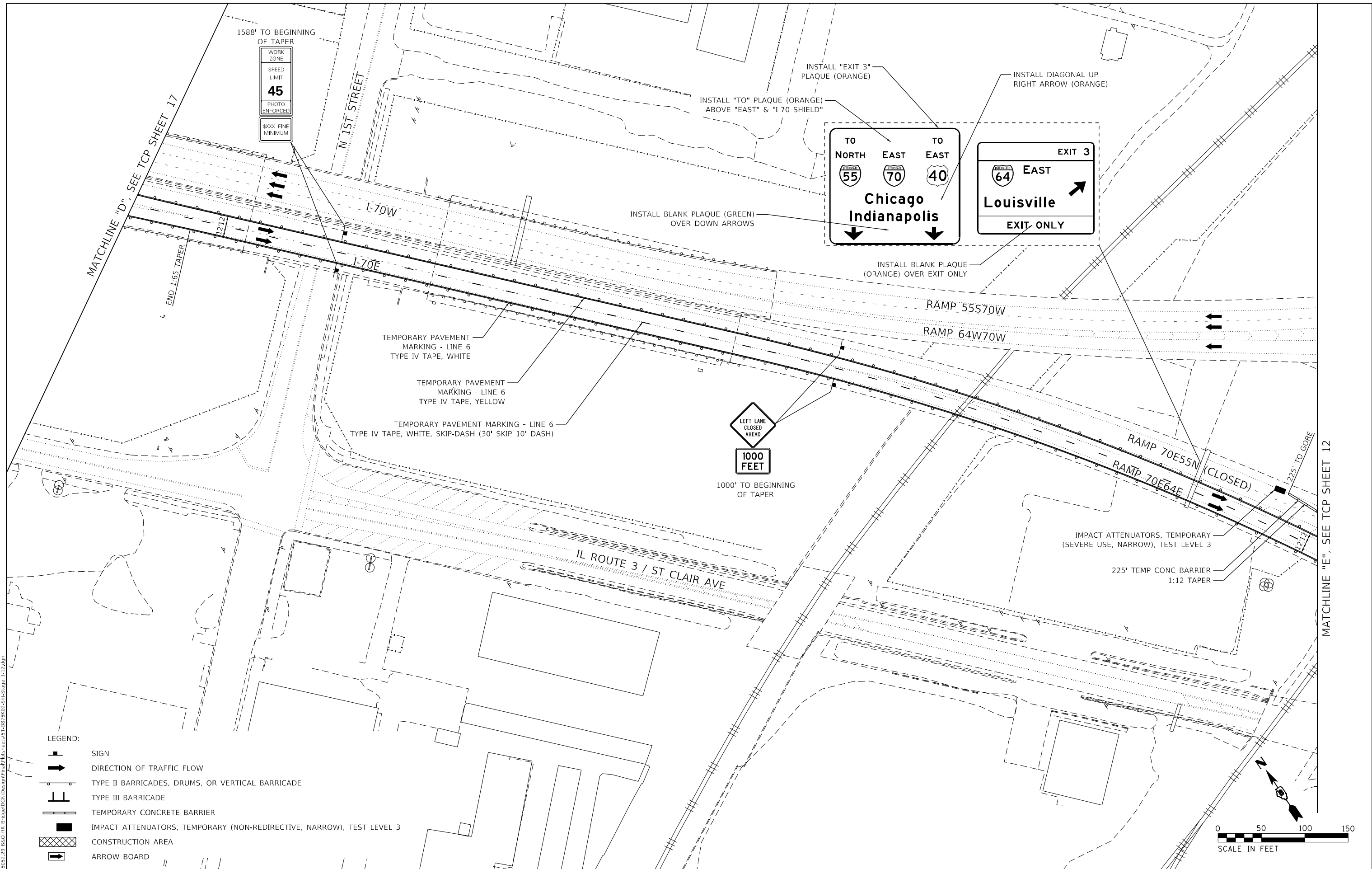

- LEGEND:**
- SIGN
 - DIRECTION OF TRAFFIC FLOW
 - TYPE II BARRICADES, DRUMS, OR VERTICAL BARRICADE
 - TYPE III BARRICADE
 - TEMPORARY CONCRETE BARRIER
 - IMPACT ATTENUATORS, TEMPORARY (NON-REDIRECTIVE, NARROW), TEST LEVEL 3
 - CONSTRUCTION AREA
 - ARROW BOARD



MODEL: 464611
 FILE NAME: Z:\13052229_B60_BR_Bridge\DCN\Design\Plan\Traffic\82-5V8-R-2-Stage 1-12.dwg
 USER: zWaters

EFK Moen
Civil Engineering Design

USER NAME = zWaters	DESIGNED - SJF	REVISED -
PLOT SCALE = 100,000' / in.	DRAWN - SJF	REVISED -
PLOT DATE = 8/13/2024	CHECKED - SLD	REVISED -
	DATE - 8/13/2024	REVISED -

**STATE OF ILLINOIS
DEPARTMENT OF TRANSPORTATION**

**TRAFFIC CONTROL AND PROTECTION PLAN
STAGE 1**

SCALE: 1"=50' SHEET 18 OF 5>TFC SHEETS STA. TO STA.

F.A.I. RTE.	SECTION	COUNTY	TOTAL SHEETS	SHEET NO.
70	82-5V8-R-2	ST. CLAIR	254	52
CONTRACT NO. 76K02				
ILLINOIS FED. AID PROJECT				

MATCHLINE "E", SEE TCP SHEET 12

MATCHLINE "F", SEE TCP SHEET 13

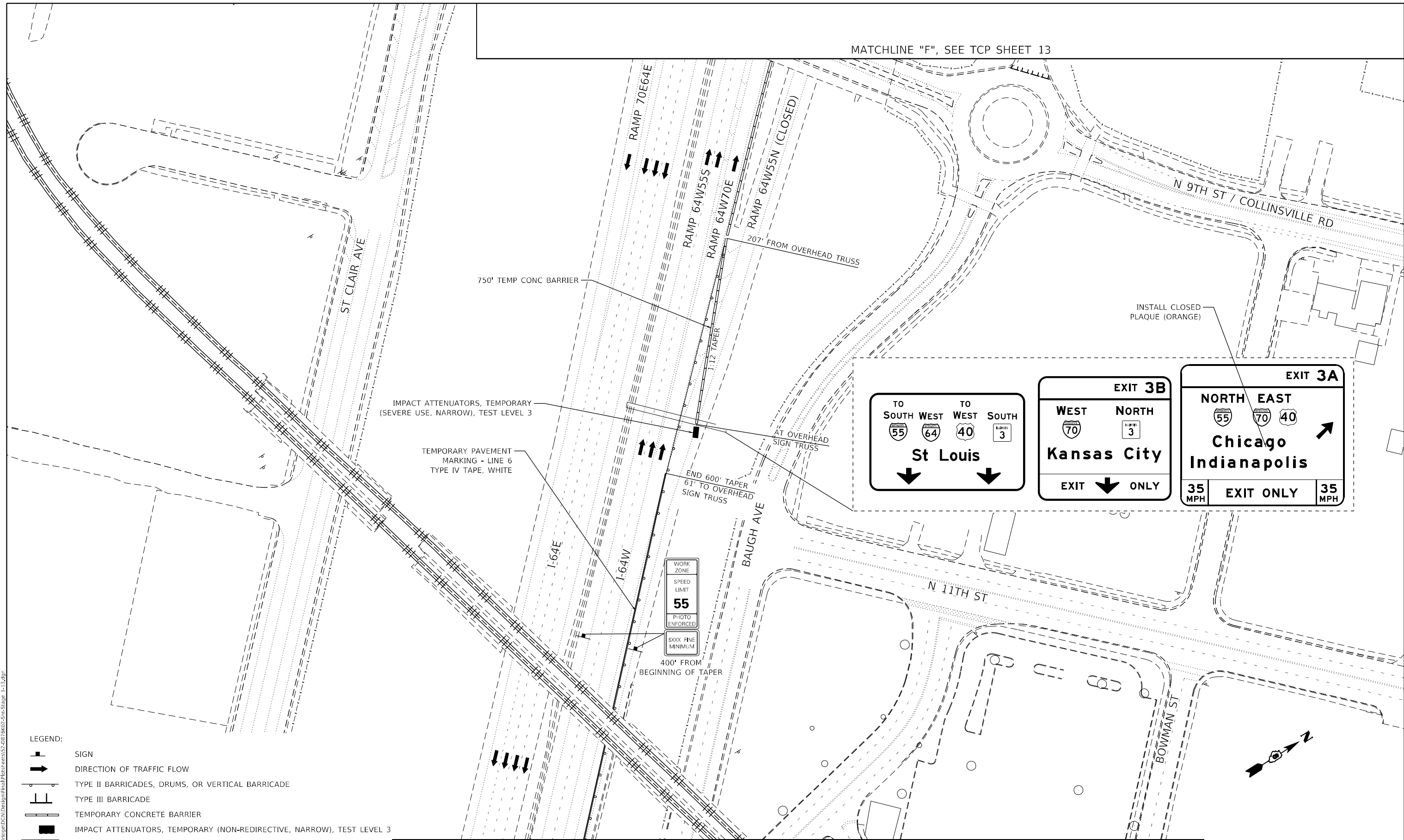

MATCHLINE "G", SEE TCP SHEET 20

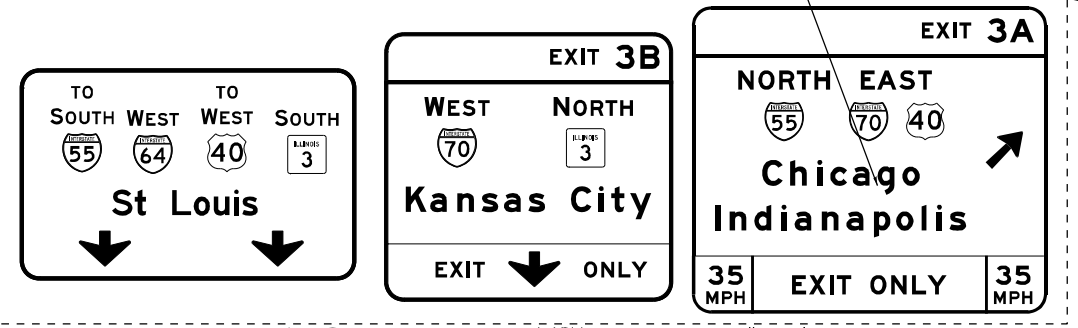

- LEGEND:**
- SIGN
 - DIRECTION OF TRAFFIC FLOW
 - TYPE II BARRICADES, DRUMS, OR VERTICAL BARRICADE
 - TYPE III BARRICADE
 - TEMPORARY CONCRETE BARRIER
 - IMPACT ATTENUATORS, TEMPORARY (NON-REDIRECTIVE, NARROW), TEST LEVEL 3
 - CONSTRUCTION AREA
 - ARROW BOARD

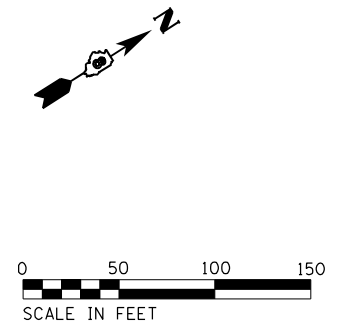

MODEL: 464611
 FILE NAME: 211305229_B60_BR_BridgeDCNDesignFinalReferences7-D878K02-Sht-Stage 1-13.dgn

EFK Moen
Civil Engineering Design

USER NAME = zWaters	DESIGNED - SJF	REVISED -
PLOT SCALE = 100,0000' / in.	DRAWN - SJF	REVISED -
PLOT DATE = 8/13/2024	CHECKED - SLD	REVISED -
	DATE - 8/13/2024	REVISED -









STATE OF ILLINOIS
DEPARTMENT OF TRANSPORTATION

TRAFFIC CONTROL AND PROTECTION PLAN
STAGE 1

SCALE: 1"=50' SHEET 19 OF 5>TFC SHEETS STA. TO STA.

F.A.I. RTE. 70	SECTION 82-5V8-R-2	COUNTY ST. CLAIR	TOTAL SHEETS 254	SHEET NO. 53
ILLINOIS FED. AID PROJECT			CONTRACT NO. 76K02	

LEGEND:

-  SIGN
-  DIRECTION OF TRAFFIC FLOW
-  TYPE II BARRICADES, DRUMS, OR VERTICAL BARRICADE
-  TYPE III BARRICADE
-  TEMPORARY CONCRETE BARRIER
-  IMPACT ATTENUATORS, TEMPORARY (NON-REDIRECTIVE, NARROW), TEST LEVEL 3
-  CONSTRUCTION AREA
-  ARROW BOARD

TEMPORARY PAVEMENT MARKING - LINE 6
TYPE IV TAPE, WHITE

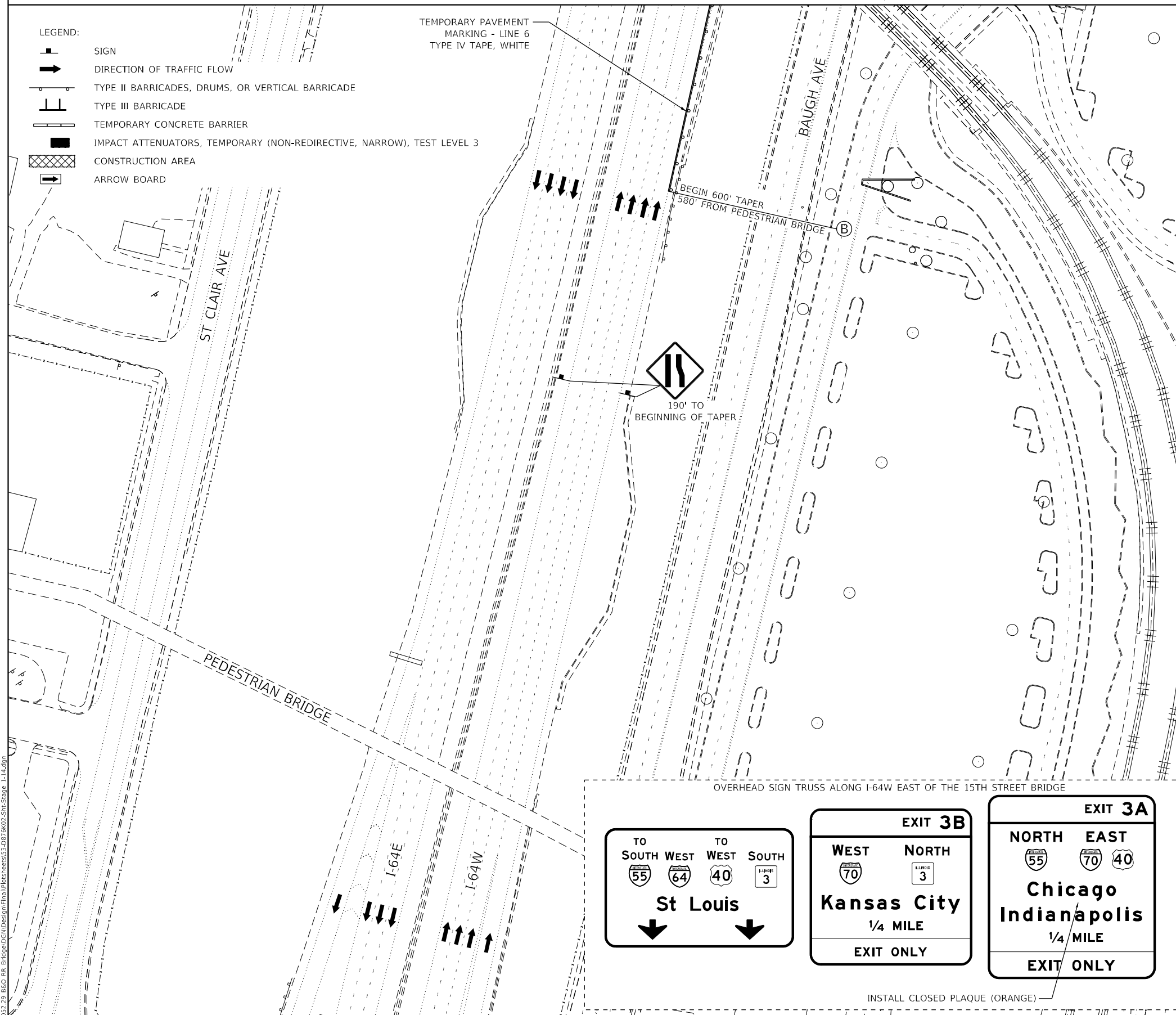

ADVANCED SIGNING ALONG I-64 (WESTBOUND)

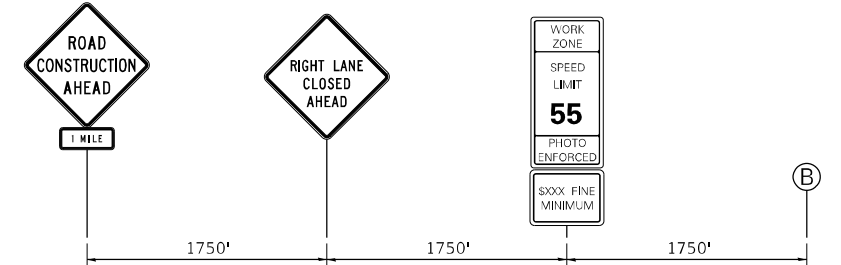

**ADVANCED SIGNING ALONG BAUGH AVE
ENTRANCE RAMP TO I-64W**

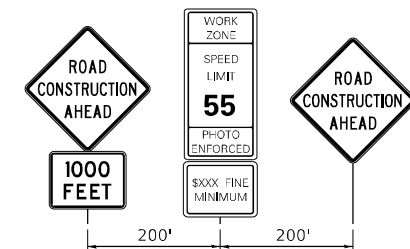

**ADVANCED SIGNING ALONG 25TH ST
ENTRANCE RAMP TO I-64W**

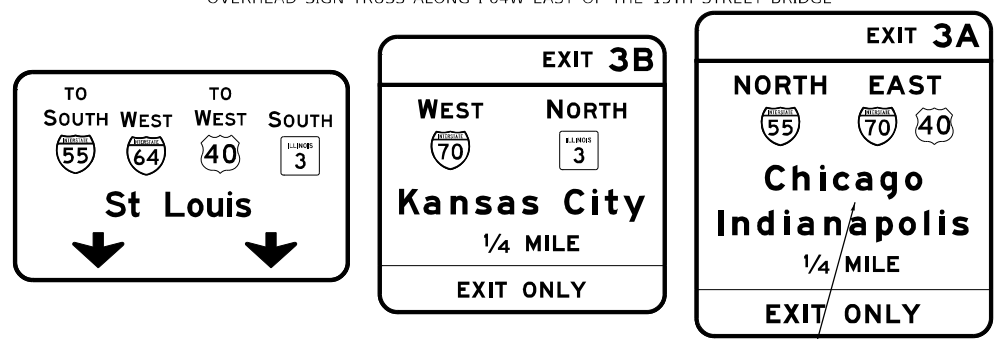
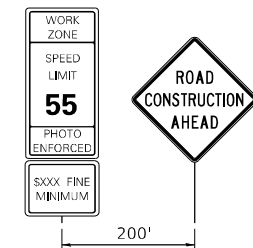

MODEL: 4/24/21
FILE NAME: 211003220_BCO_BR_BridgeDesign\Final\Revised\53-D078K02-Sht-Stage 1-14.dwg

EFK Moen
Civil Engineering Design

USER NAME = zWaters	DESIGNED - SJF	REVISED -
PLOT SCALE = 100,000' / in.	DRAWN - SJF	REVISED -
PLOT DATE = 8/13/2024	CHECKED - SLD	REVISED -
	DATE - 8/13/2024	REVISED -

**STATE OF ILLINOIS
DEPARTMENT OF TRANSPORTATION**

**TRAFFIC CONTROL AND PROTECTION PLAN
STAGE 1**

SCALE: 1"=50' SHEET 20 OF 5>TFC SHEETS STA. TO STA.

F.A.I. RTE.	SECTION	COUNTY	TOTAL SHEETS	SHEET NO.
70	82-5V8-R-2	ST. CLAIR	254	54
ILLINOIS FED. AID PROJECT			CONTRACT NO. 76K02	

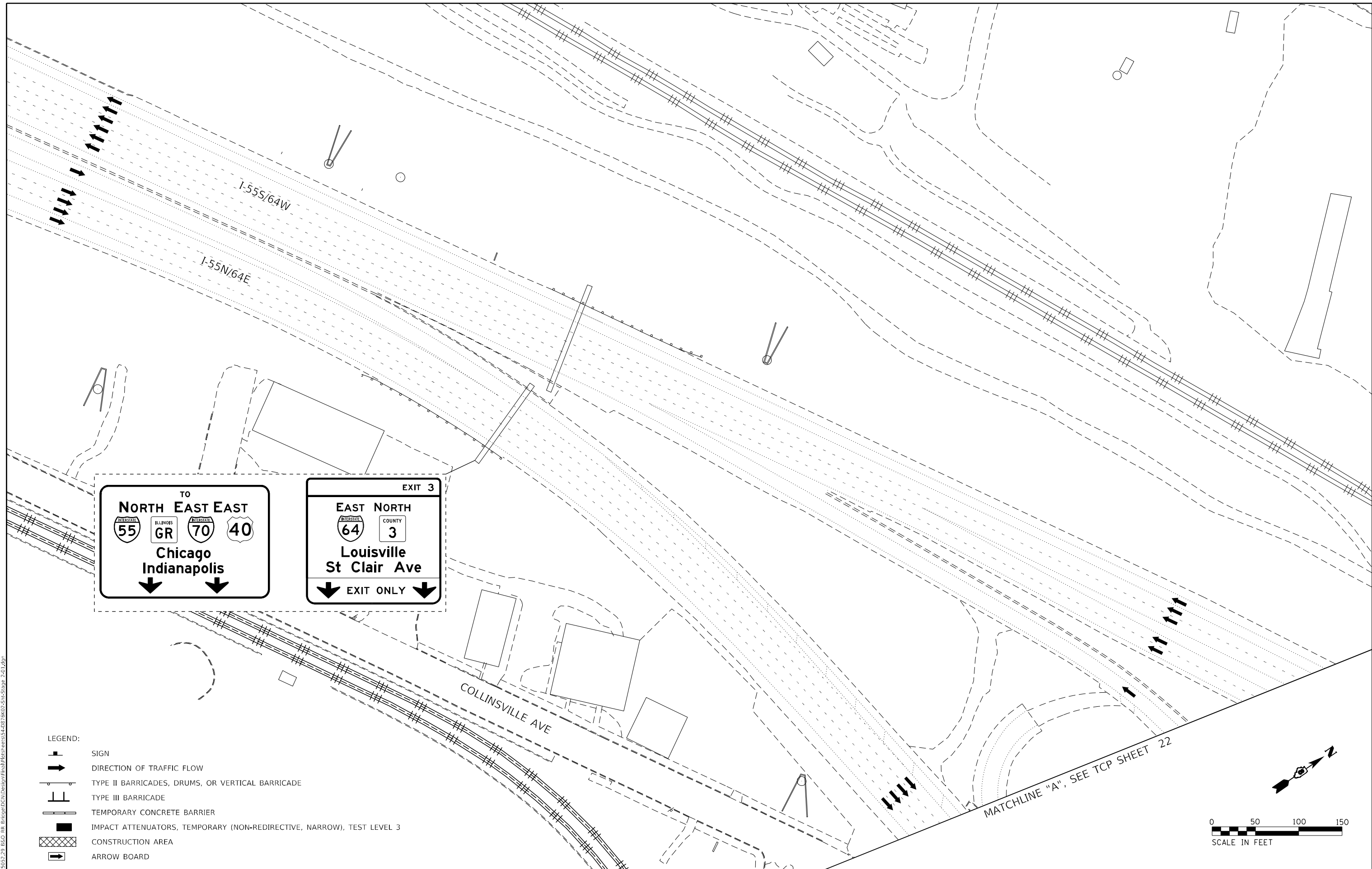

TO
NORTH EAST EAST
 I-55 ILLINOIS GR I-70 I-40
Chicago Indianapolis

EXIT 3
EAST NORTH
 I-64 COUNTY 3
Louisville St Clair Ave
 EXIT ONLY

- LEGEND:
- SIGN
 - DIRECTION OF TRAFFIC FLOW
 - TYPE II BARRICADES, DRUMS, OR VERTICAL BARRICADE
 - TYPE III BARRICADE
 - TEMPORARY CONCRETE BARRIER
 - IMPACT ATTENUATORS, TEMPORARY (NON-REDIRECTIVE, NARROW), TEST LEVEL 3
 - CONSTRUCTION AREA
 - ARROW BOARD

MODEL: 464611
 FILE NAME: 211305229_BEG_BR_BridgeDCN(Driver)FinalReferences54.DWG(800-514-514) 24.01.dwg

EFK Moen
 Civil Engineering Design

USER NAME = zWaters
 PLOT SCALE = 100,0000' / in.
 PLOT DATE = 8/13/2024

DESIGNED - SJF
 DRAWN - SJF
 CHECKED - SLD
 DATE - 8/13/2024

REVISED -
 REVISED -
 REVISED -
 REVISED -









**STATE OF ILLINOIS
 DEPARTMENT OF TRANSPORTATION**

**TRAFFIC CONTROL AND PROTECTION PLAN
 STAGE 2**

SCALE: 1"=50' SHEET 21 OF 5>TFC SHEETS STA. TO STA.

F.A.I. RTE.	SECTION	COUNTY	TOTAL SHEETS	SHEET NO.
70	82-5V8-R-2	ST. CLAIR	254	55
CONTRACT NO. 76K02				
ILLINOIS FED. AID PROJECT				

LEGEND:

-  SIGN
-  DIRECTION OF TRAFFIC FLOW
-  TYPE II BARRICADES, DRUMS, OR VERTICAL BARRICADE
-  TYPE III BARRICADE
-  TEMPORARY CONCRETE BARRIER
-  IMPACT ATTENUATORS, TEMPORARY (NON-REDIRECTIVE, NARROW), TEST LEVEL 3
-  CONSTRUCTION AREA
-  ARROW BOARD

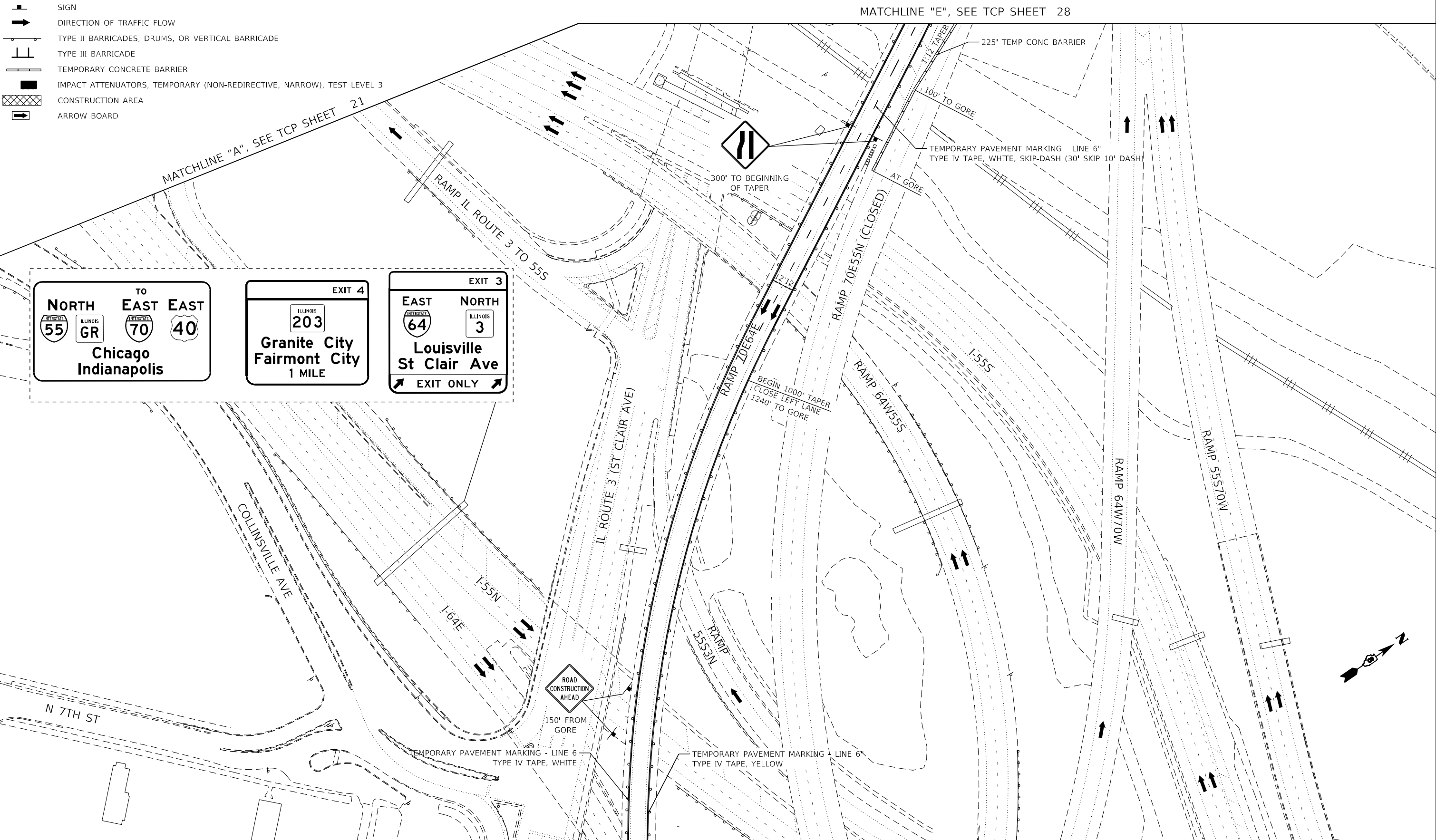

TO EAST EAST

NORTH **EAST**

55 GR 70 40

Chicago
Indianapolis

EXIT 4

ILLINOIS 203

Granite City
Fairmont City

1 MILE

EXIT 3

EAST NORTH

64 3

Louisville
St Clair Ave

EXIT ONLY

MODEL: 464611
 FILE NAME: Z:\13052229_BCO_BR_Bridge\DC\Design\Final\Revised\55-0876K02-Sub-Stage 2.dwg
 USER NAME = zWaters

EFK Moen
Civil Engineering Design

DESIGNED - SJF	REVISD -
DRAWN - SJF	REVISD -
CHECKED - SLD	REVISD -
DATE - 8/13/2024	REVISD -

STATE OF ILLINOIS
DEPARTMENT OF TRANSPORTATION

TRAFFIC CONTROL AND PROTECTION PLAN
STAGE 2

SCALE: 1"=50' SHEET 22 OF 5>TFC SHEETS STA. TO STA.

F.A.I. RTE.	SECTION	COUNTY	TOTAL SHEETS	SHEET NO.
70	82-5V8-R-2	ST. CLAIR	254	56
CONTRACT NO. 76K02				
ILLINOIS FED. AID PROJECT				



MATCHLINE "A", SEE TCP SHEET 21 MATCHLINE "B", SEE TCP SHEET 23 MATCHLINE "E", SEE TCP SHEET 28

MATCHLINE "B", SEE TCP SHEET 22

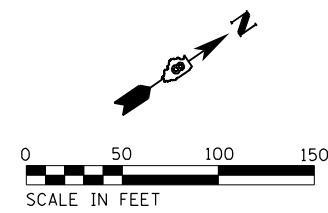
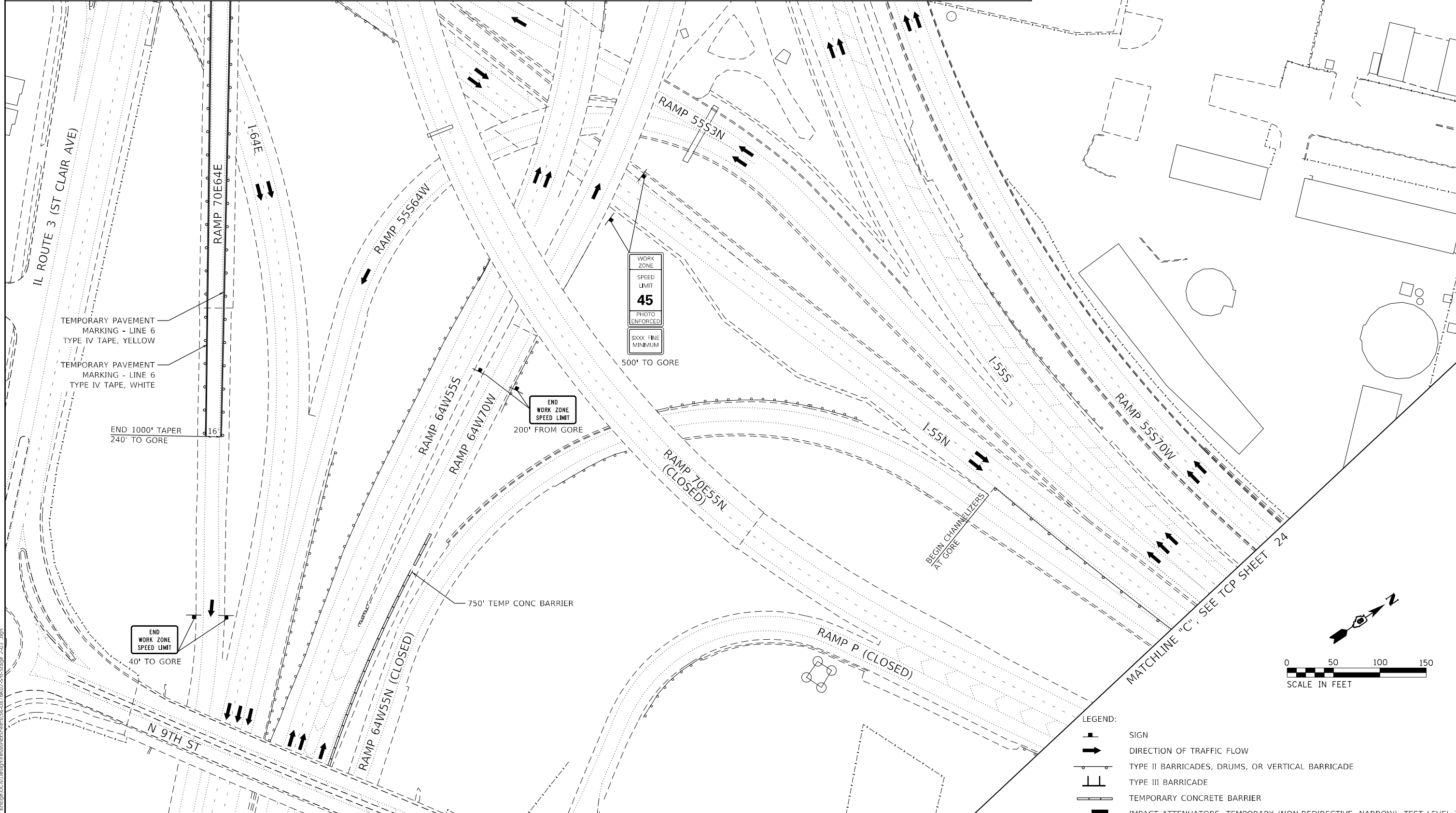

MATCHLINE "F", SEE TCP SHEET 29

MODEL: 4646.dwg
 FILE NAME: Z:\13052229.B60_BB_Bridge\DCN\Design\Final\Traffic\76K02-Stage 2.dwg
 DATE: 8/13/2024

EFK Moen
Civil Engineering Design

USER NAME = zWaters
 PLOT SCALE = 100,0000' / in.
 PLOT DATE = 8/13/2024

DESIGNED - SJF
 DRAWN - SJF
 CHECKED - SLD
 DATE - 8/13/2024









REVISED -
 REVISED -
 REVISED -
 REVISED -

**STATE OF ILLINOIS
 DEPARTMENT OF TRANSPORTATION**

**TRAFFIC CONTROL AND PROTECTION PLAN
 STAGE 2**

SCALE: 1"=50' SHEET 23 OF 5>TFC SHEETS STA. TO STA.

F.A.I. RTE.	SECTION	COUNTY	TOTAL SHEETS	SHEET NO.
70	82-5V8-R-2	ST. CLAIR	254	57
CONTRACT NO. 76K02			ILLINOIS FED. AID PROJECT	

- LEGEND:**
-  SIGN
 -  DIRECTION OF TRAFFIC FLOW
 -  TYPE II BARRICADES, DRUMS, OR VERTICAL BARRICADE
 -  TYPE III BARRICADE
 -  TEMPORARY CONCRETE BARRIER
 -  IMPACT ATTENUATORS, TEMPORARY (NON-REDIRECTIVE, NARROW), TEST LEVEL 3
 -  CONSTRUCTION AREA
 -  ARROW BOARD

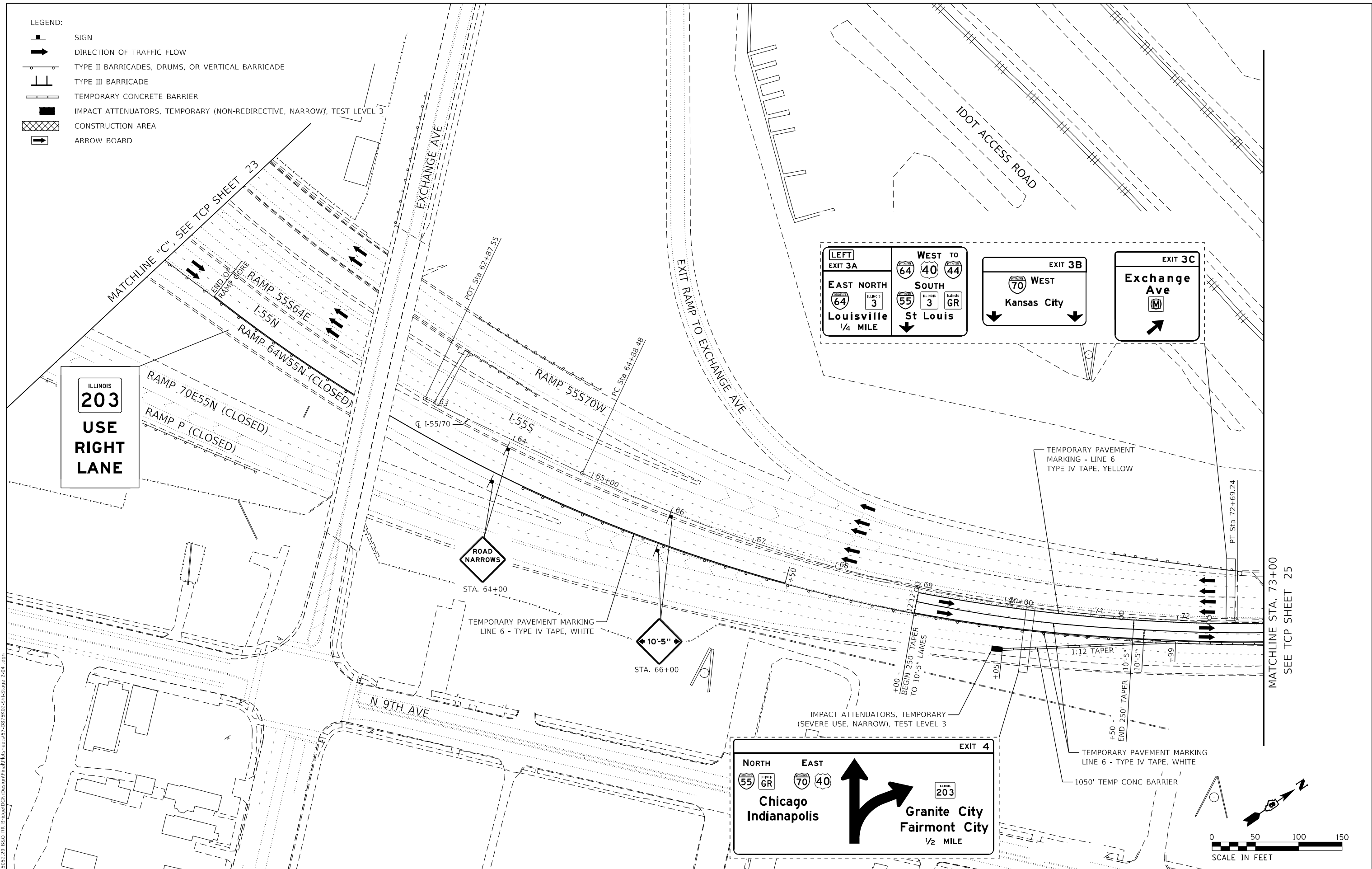

ILLINOIS
203
USE
RIGHT
LANE

LEFT EXIT 3A	WEST TO EXIT 3B	EXIT 3C

EXIT 4

NORTH EXIT 55 GR	EAST EXIT 70 40	EXIT 203
Chicago Indianapolis		Granite City Fairmont City
1/2 MILE		

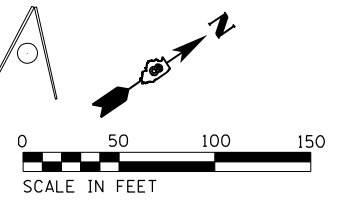

MODEL: 464611
 FILE NAME: Z:\130522-29_BCO_BR_Bldg\DC\Design\Plan\Traffic\Sheet57-D076K02-Sub-Stage 2-04.dgn
 DATE: 8/13/2024

EFK Moen
Civil Engineering Design

USER NAME = zWaters	DESIGNED - SJF	REVISED -
PLOT SCALE = 100,0000' / in.	DRAWN - SJF	REVISED -
PLOT DATE = 8/13/2024	CHECKED - SLD	REVISED -
	DATE - 8/13/2024	REVISED -

STATE OF ILLINOIS
DEPARTMENT OF TRANSPORTATION

TRAFFIC CONTROL AND PROTECTION PLAN
STAGE 2

SCALE: 1"=50' SHEET 24 OF 5>TFC SHEETS STA. 62+87.55 TO STA. 73+00

F.A.I. RTE.	SECTION	COUNTY	TOTAL SHEETS	SHEET NO.
70	82-5V8-R-2	ST. CLAIR	254	58
CONTRACT NO. 76K02				
ILLINOIS FED. AID PROJECT				

- LEGEND:
- SIGN
 - DIRECTION OF TRAFFIC FLOW
 - TYPE II BARRICADES, DRUMS, OR VERTICAL BARRICADE
 - TYPE III BARRICADE
 - TEMPORARY CONCRETE BARRIER
 - IMPACT ATTENUATORS, TEMPORARY (NON-REDIRECTIVE, NARROW), TEST LEVEL 3
 - CONSTRUCTION AREA
 - ARROW BOARD

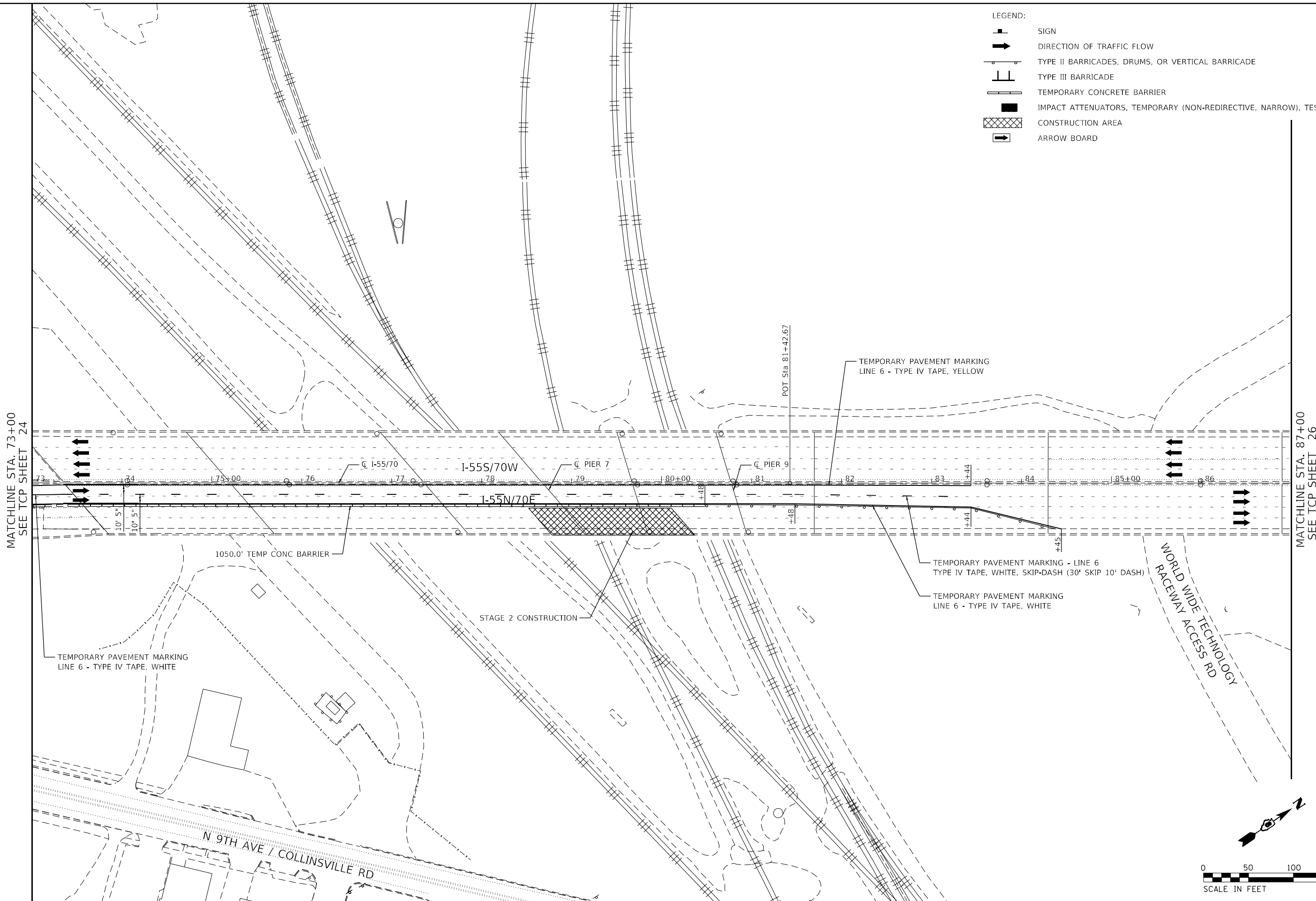

MATCHLINE STA. 73+00
SEE TCP SHEET 24

MATCHLINE STA. 87+00
SEE TCP SHEET 26

MODEL: 464611
 FILE NAME: Z:\13052229_BCO_BR_Bridge\DCN\Design\Final\Fetch\Sheet58.DWG\K02_Sht-Stage_2.dwg

EFK Moen
Civil Engineering Design

USER NAME = zWaters	DESIGNED - SJF	REVISED -
PLOT SCALE = 100,0000' / in.	DRAWN - SJF	REVISED -
PLOT DATE = 8/13/2024	CHECKED - SLD	REVISED -
	DATE - 8/13/2024	REVISED -

**STATE OF ILLINOIS
DEPARTMENT OF TRANSPORTATION**







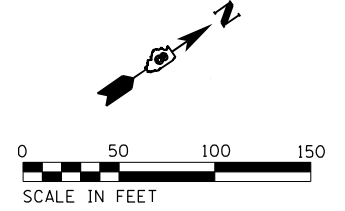

**TRAFFIC CONTROL AND PROTECTION PLAN
STAGE 2**

SCALE: 1"=50' SHEET 25 OF 5>TFC SHEETS STA. 73+00 TO STA. 87+00

F.A.I. RTE.	SECTION	COUNTY	TOTAL SHEETS	SHEET NO.
70	82-5V8-R-2	ST. CLAIR	254	59
CONTRACT NO. 76K02				
ILLINOIS FED. AID PROJECT				



LEGEND:

-  SIGN
-  DIRECTION OF TRAFFIC FLOW
-  TYPE II BARRICADES, DRUMS, OR VERTICAL BARRICADE
-  TYPE III BARRICADE
-  TEMPORARY CONCRETE BARRIER
-  IMPACT ATTENUATORS, TEMPORARY (NON-REDIRECTIVE, NARROW), TEST LEVEL 3
-  CONSTRUCTION AREA
-  ARROW BOARD

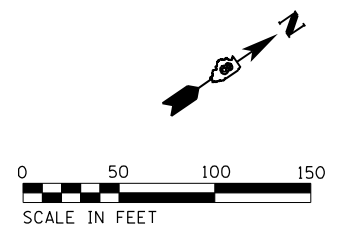
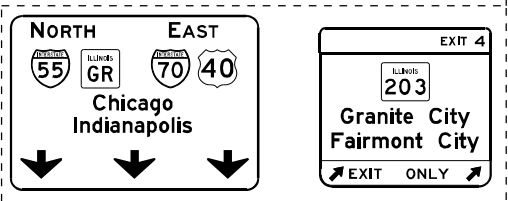
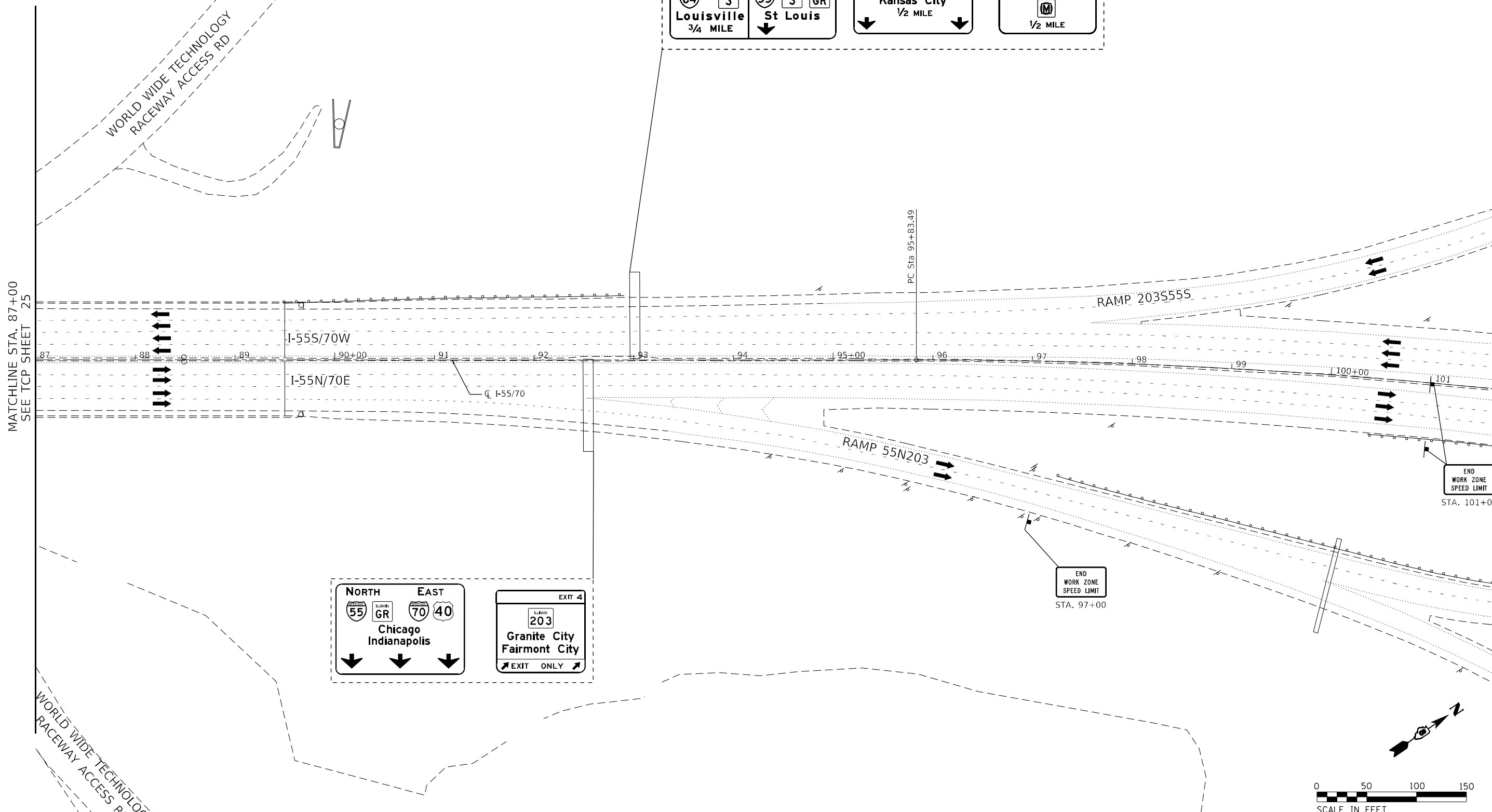
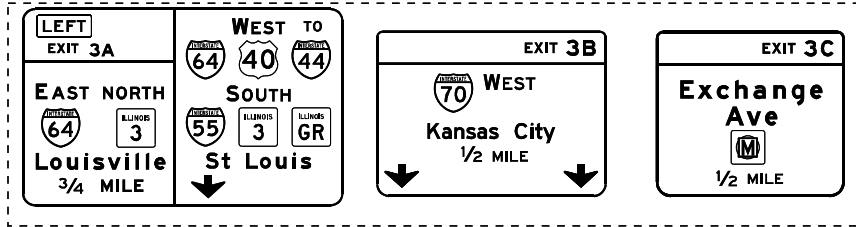

MODEL: d:\efk\h...
 FILE NAME: Z:\130522\29_B60_BR_Bridge\DCN\Design\Final\Fiber\Sheet\59\076K02_Sht-Stage_2_06.dgn

EFK Moen
Civil Engineering Design

USER NAME = zWaters	DESIGNED - SJF	REVISED -
PLOT SCALE = 100,0000' / in.	DRAWN - SJF	REVISED -
PLOT DATE = 8/13/2024	CHECKED - SLD	REVISED -
	DATE - 8/13/2024	REVISED -

**STATE OF ILLINOIS
DEPARTMENT OF TRANSPORTATION**

**TRAFFIC CONTROL AND PROTECTION PLAN
STAGE 2**

SCALE: 1"=50' SHEET 26 OF 5>TFC SHEETS STA. 87+00 TO STA. 100+00

F.A.I. RTE.	SECTION	COUNTY	TOTAL SHEETS	SHEET NO.
70	82-5V8-R-2	ST. CLAIR	254	60
CONTRACT NO. 76K02			ILLINOIS FED. AID PROJECT	

ADVANCED SIGNING ALONG I-70 (WESTBOUND)

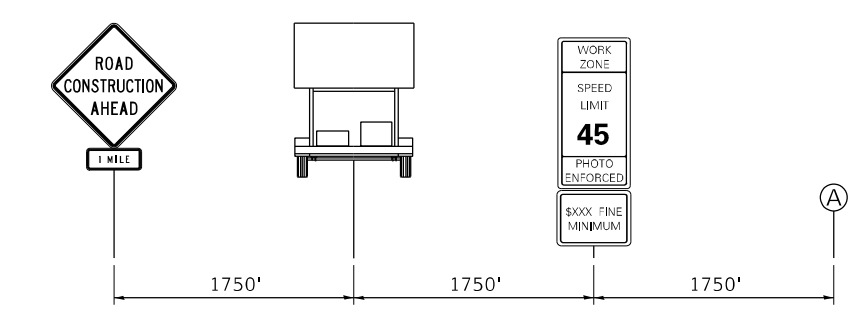

NOTE:
1. ADVANCED WARNING SIGNS SHALL BE PLACED ON EITHER SIDE OF WESTBOUND I-70.

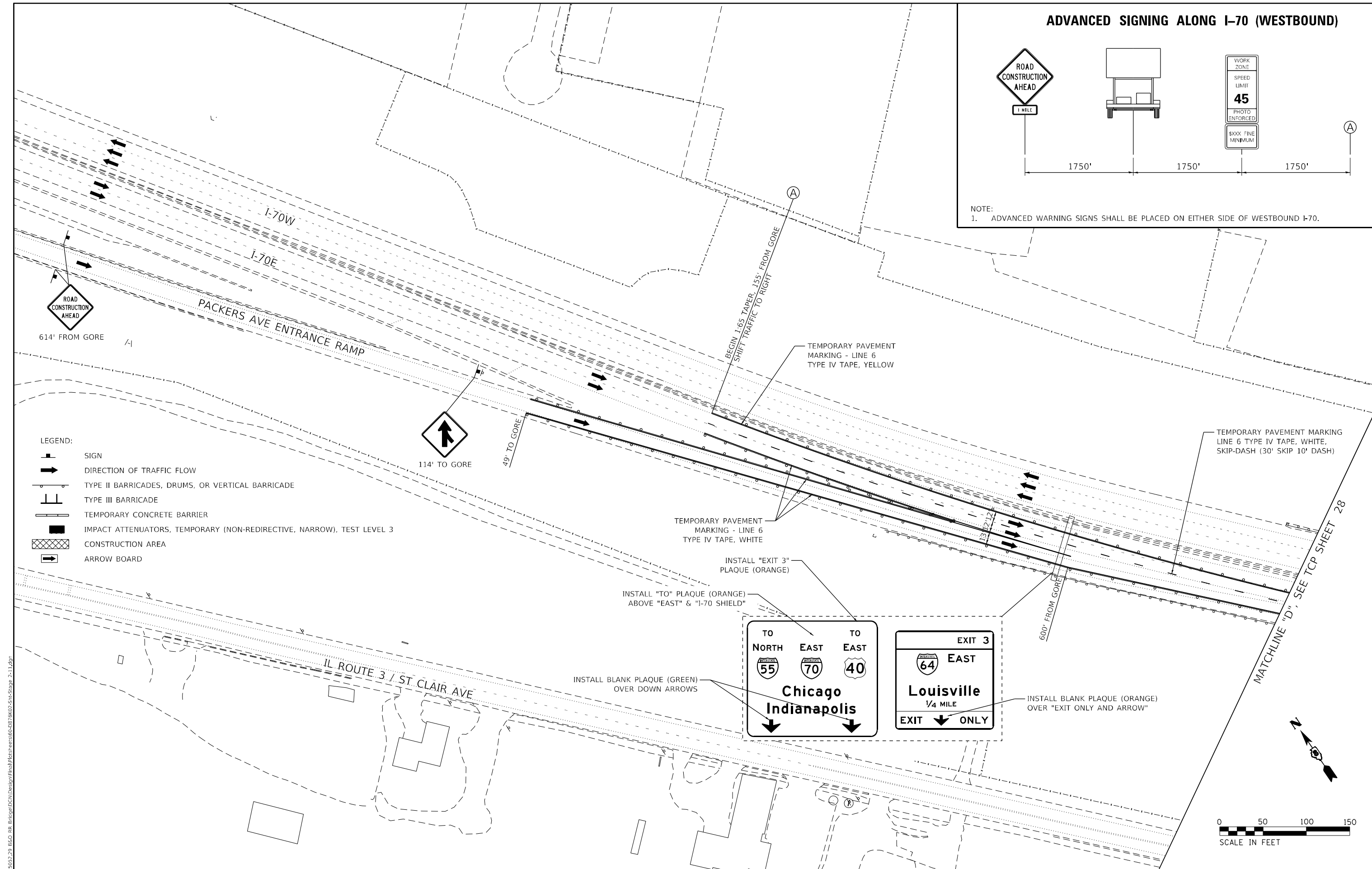

- LEGEND:**
- SIGN
 - DIRECTION OF TRAFFIC FLOW
 - TYPE II BARRICADES, DRUMS, OR VERTICAL BARRICADE
 - TYPE III BARRICADE
 - TEMPORARY CONCRETE BARRIER
 - IMPACT ATTENUATORS, TEMPORARY (NON-REDIRECTIVE, NARROW), TEST LEVEL 3
 - CONSTRUCTION AREA
 - ARROW BOARD

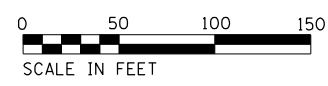
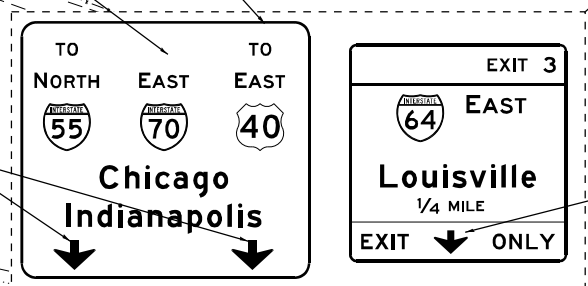

MODEL: 464611
 FILE NAME: Z:\2023\23_BCO_BR_Bridge\DCN\Design\Final\Final\Sheet\82-5V8-R-2-1.dgn
 USER: z2waters

EFK Moen
Civil Engineering Design

USER NAME = z2waters	DESIGNED - SJF	REVISED -
PLOT SCALE = 100,0000' / in.	DRAWN - SJF	REVISED -
PLOT DATE = 8/13/2024	CHECKED - SLD	REVISED -
	DATE - 8/13/2024	REVISED -

**STATE OF ILLINOIS
DEPARTMENT OF TRANSPORTATION**

**TRAFFIC CONTROL AND PROTECTION PLAN
STAGE 2**

F.A.I. RTE.	SECTION	COUNTY	TOTAL SHEETS	SHEET NO.
70	82-5V8-R-2	ST. CLAIR	254	61
CONTRACT NO. 76K02			ILLINOIS FED. AID PROJECT	

SCALE: 1"=50' SHEET 27 OF 5>TFC SHEETS STA. TO STA.

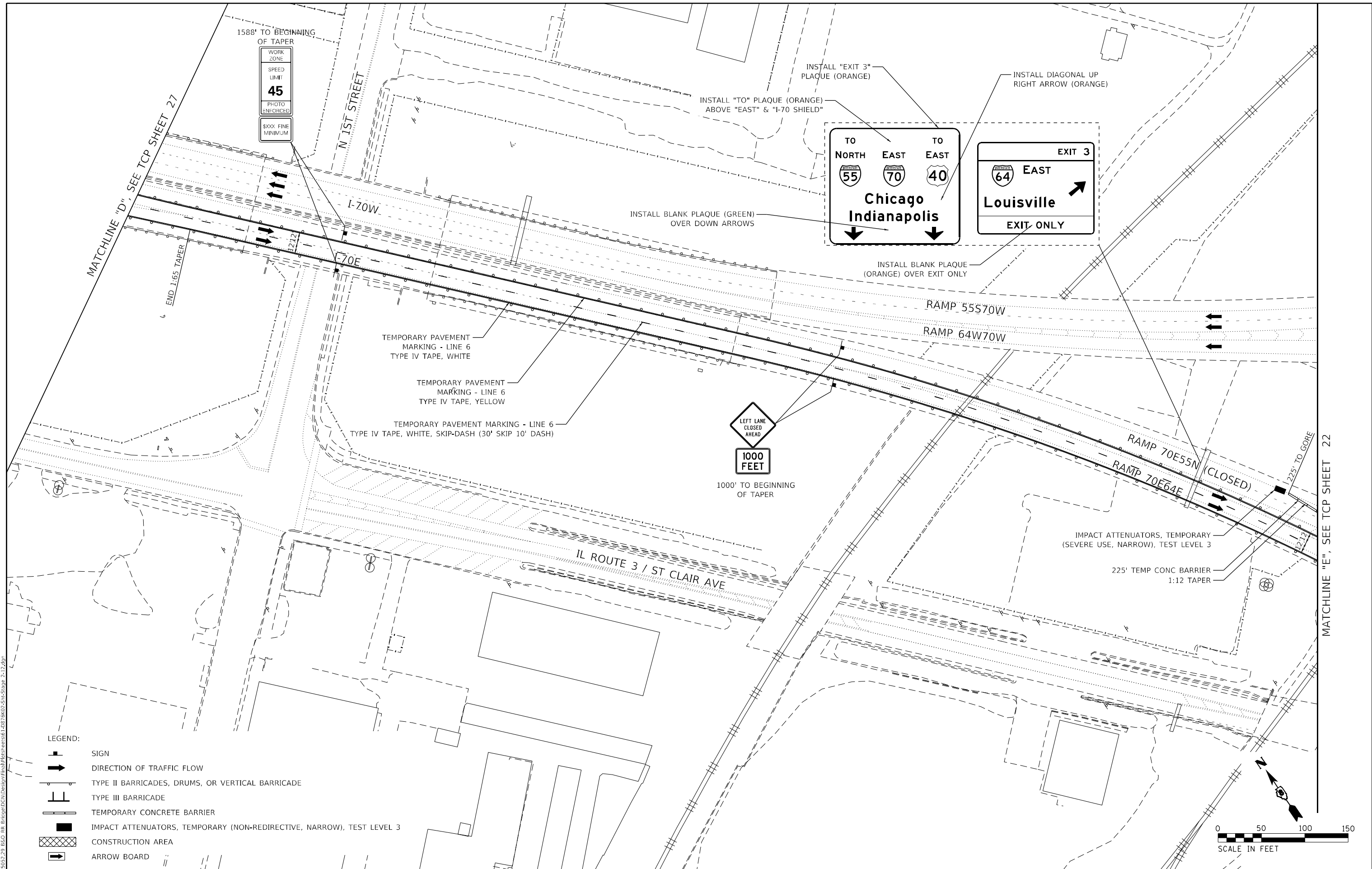

MATCHLINE "D", SEE TCP SHEET 27

1588' TO BEGINNING OF TAPER

WORK ZONE

SPEED LIMIT

45

PHOTO ENFORCED

\$300 FINE MINIMUM

N 1ST STREET

INSTALL "EXIT 3" PLAQUE (ORANGE)

INSTALL "TO" PLAQUE (ORANGE) ABOVE "EAST" & "I-70 SHIELD"

INSTALL DIAGONAL UP RIGHT ARROW (ORANGE)

TO NORTH 55

TO EAST 70

TO EAST 40

Chicago Indianapolis

EXIT 3

64 EAST

Louisville

EXIT ONLY

INSTALL BLANK PLAQUE (GREEN) OVER DOWN ARROWS

INSTALL BLANK PLAQUE (ORANGE) OVER EXIT ONLY

END 1:65 TAPER

TEMPORARY PAVEMENT MARKING - LINE 6 TYPE IV TAPE, WHITE

TEMPORARY PAVEMENT MARKING - LINE 6 TYPE IV TAPE, YELLOW

TEMPORARY PAVEMENT MARKING - LINE 6 TYPE IV TAPE, WHITE, SKIP-DASH (30' SKIP 10' DASH)

LEFT LANE CLOSED AHEAD

1000 FEET

1000' TO BEGINNING OF TAPER

RAMP 55S70W

RAMP 64W70W

RAMP 70E55N (CLOSED)

RAMP 70E64E

IL ROUTE 3 / ST CLAIR AVE

IMPACT ATTENUATORS, TEMPORARY (SEVERE USE, NARROW), TEST LEVEL 3

225' TEMP CONC BARRIER 1:12 TAPER

- LEGEND:
- SIGN
 - DIRECTION OF TRAFFIC FLOW
 - TYPE II BARRICADES, DRUMS, OR VERTICAL BARRICADE
 - TYPE III BARRICADE
 - TEMPORARY CONCRETE BARRIER
 - IMPACT ATTENUATORS, TEMPORARY (NON-REDIRECTIVE, NARROW), TEST LEVEL 3
 - CONSTRUCTION AREA
 - ARROW BOARD

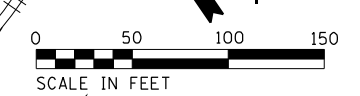

MODEL: 464611
FILE NAME: 211305229_B60_BR_BridgeDCNDesign\Final\Sheet\61-D878K02-Sub-Stage 2-12.dwg

EFK Moen
Civil Engineering Design

USER NAME = zWaters

DESIGNED - SJF

DRAWN - SJF

PLLOT SCALE = 100,0000' / in.

CHECKED - SLD

DATE - 8/13/2024

REVISED -

REVISED -

REVISED -

REVISED -

STATE OF ILLINOIS
DEPARTMENT OF TRANSPORTATION

TRAFFIC CONTROL AND PROTECTION PLAN
STAGE 2

SCALE: 1"=50' SHEET 28 OF 5>TFC SHEETS STA. TO STA.

F.A.I. RTE.	SECTION	COUNTY	TOTAL SHEETS	SHEET NO.
70	82-5V8-R-2	ST. CLAIR	254	62
CONTRACT NO. 76K02				

ILLINOIS FED. AID PROJECT

MATCHLINE "E", SEE TCP SHEET 22

MATCHLINE "F", SEE TCP SHEET 23

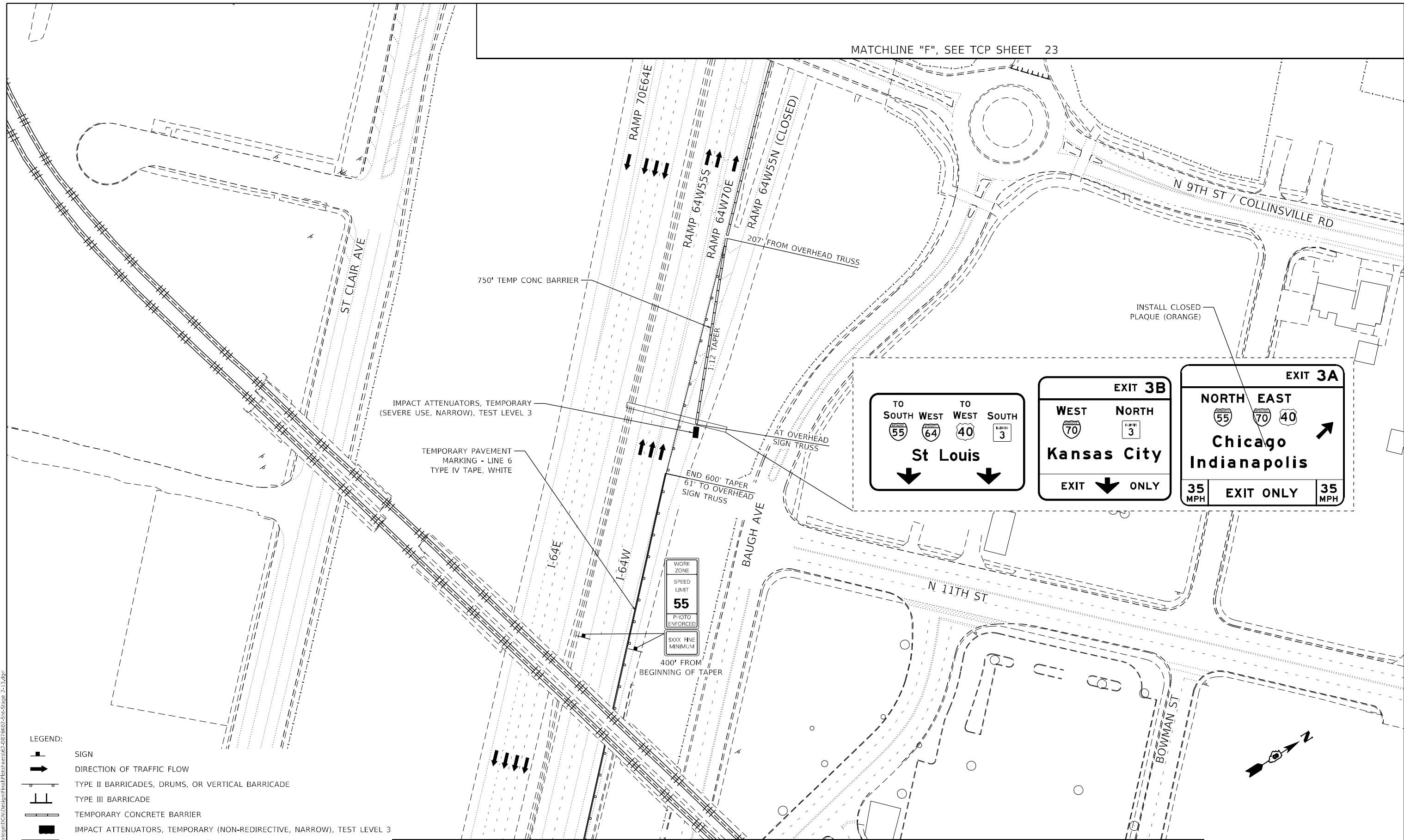

MATCHLINE "G", SEE TCP SHEET 30

- LEGEND:**
- SIGN
 - DIRECTION OF TRAFFIC FLOW
 - TYPE II BARRICADES, DRUMS, OR VERTICAL BARRICADE
 - TYPE III BARRICADE
 - TEMPORARY CONCRETE BARRIER
 - IMPACT ATTENUATORS, TEMPORARY (NON-REDIRECTIVE, NARROW), TEST LEVEL 3
 - CONSTRUCTION AREA
 - ARROW BOARD

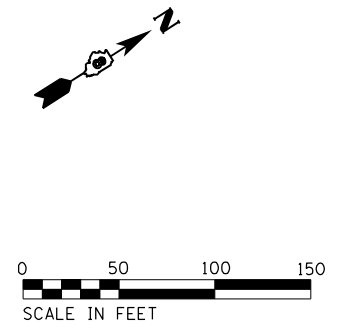
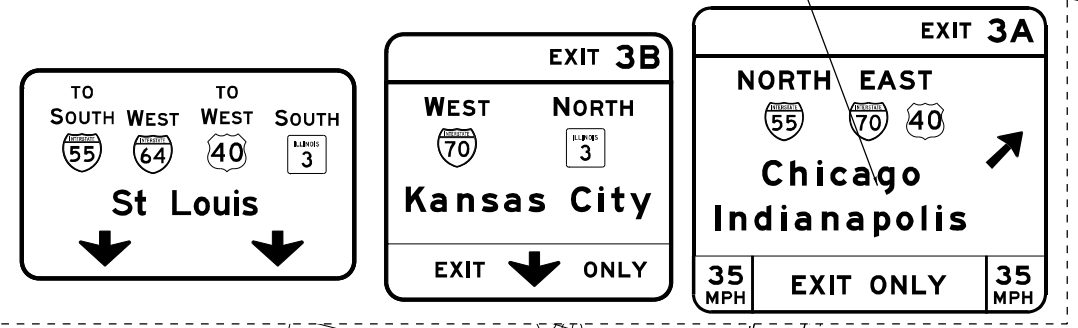

MODEL: 464611
 FILE NAME: 211305229_B60_BR_BridgeDCNDesignFinalRevised62-D878K02-Sht-Stage 2-13.dgn

EFK Moen
Civil Engineering Design

USER NAME = zWaters	DESIGNED - SJF	REVISED -
	DRAWN - SJF	REVISED -
PLOT SCALE = 100,0000' / in.	CHECKED - SLD	REVISED -
PLOT DATE = 8/13/2024	DATE - 8/13/2024	REVISED -

STATE OF ILLINOIS
DEPARTMENT OF TRANSPORTATION

TRAFFIC CONTROL AND PROTECTION PLAN
STAGE 2

SCALE: 1"=50' SHEET 29 OF 5>TFC SHEETS STA. TO STA.

F.A.I. RTE.	SECTION	COUNTY	TOTAL SHEETS	SHEET NO.
70	82-5V8-R-2	ST. CLAIR	254	63
CONTRACT NO. 76K02				
ILLINOIS FED. AID PROJECT				

LEGEND:

- SIGN
- DIRECTION OF TRAFFIC FLOW
- TYPE II BARRICADES, DRUMS, OR VERTICAL BARRICADE
- TYPE III BARRICADE
- TEMPORARY CONCRETE BARRIER
- IMPACT ATTENUATORS, TEMPORARY (NON-REDIRECTIVE, NARROW), TEST LEVEL 3
- CONSTRUCTION AREA
- ARROW BOARD

TEMPORARY PAVEMENT MARKING - LINE 6
TYPE IV TAPE, WHITE

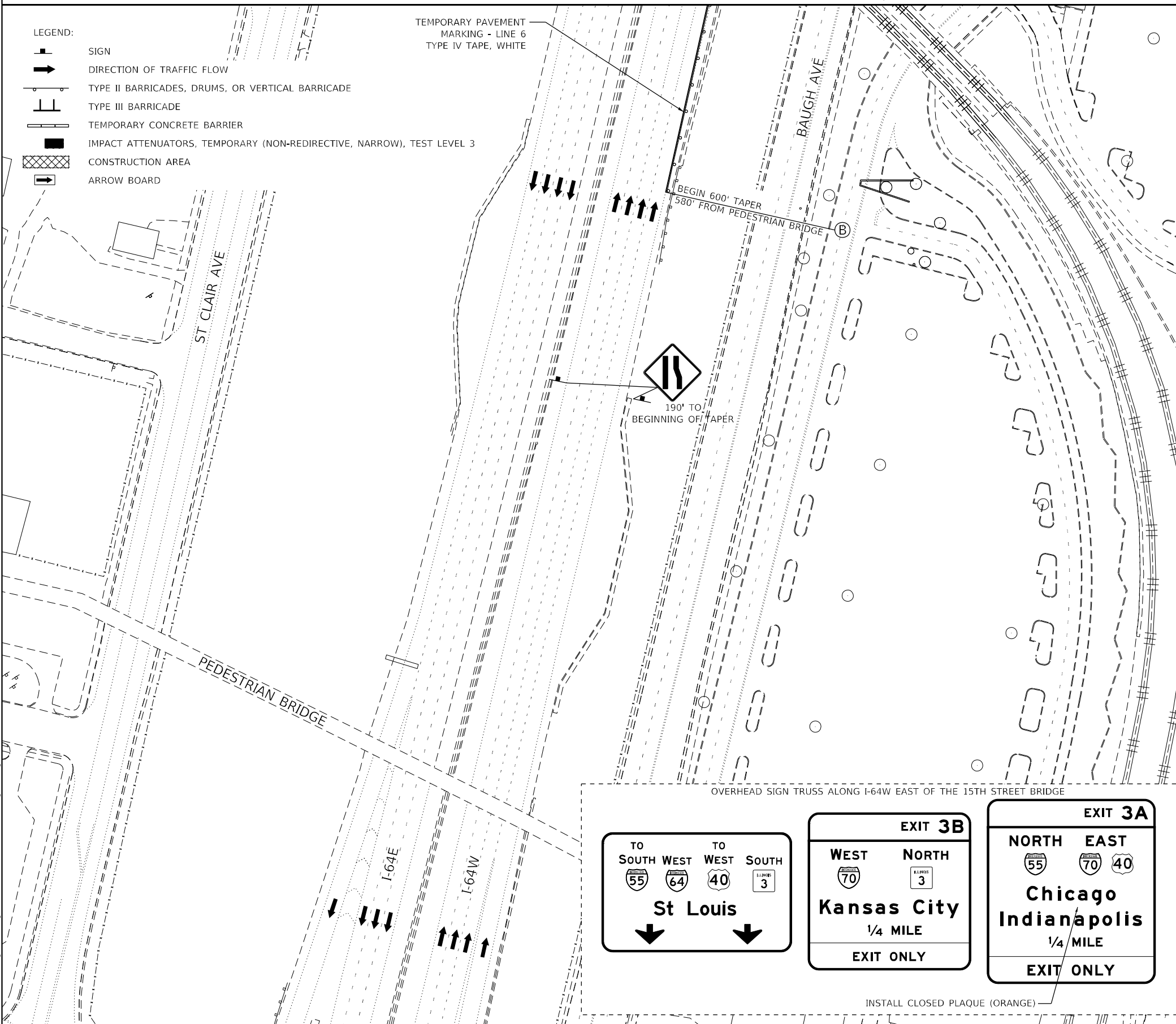

ADVANCED SIGNING ALONG I-64 (WESTBOUND)

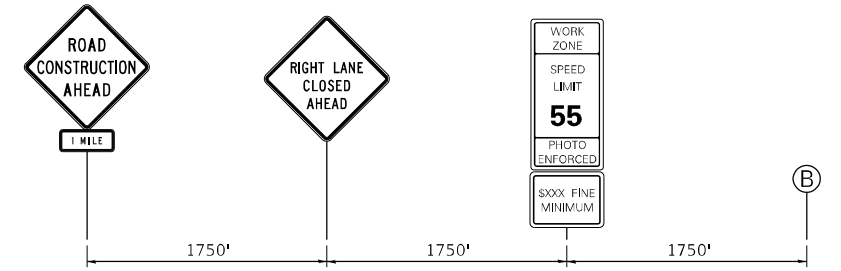

NOTE:
1. ALL ADVANCED WARNING SIGNS SHALL BE PLACED ON EITHER SIDE OF WESTBOUND I-64.

**ADVANCED SIGNING ALONG BAUGH AVE
ENTRANCE RAMP TO I-64W**

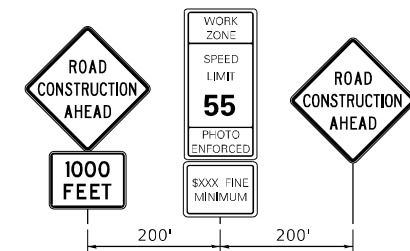

NOTE:
1. ALL ADVANCED WARNING SIGNS SHALL BE PLACED ON EITHER SIDE OF THE RAMP.

**ADVANCED SIGNING ALONG 25TH ST
ENTRANCE RAMP TO I-64W**

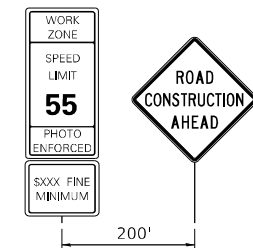

NOTE:
1. ALL ADVANCED WARNING SIGNS SHALL BE PLACED ON EITHER SIDE OF THE RAMP.

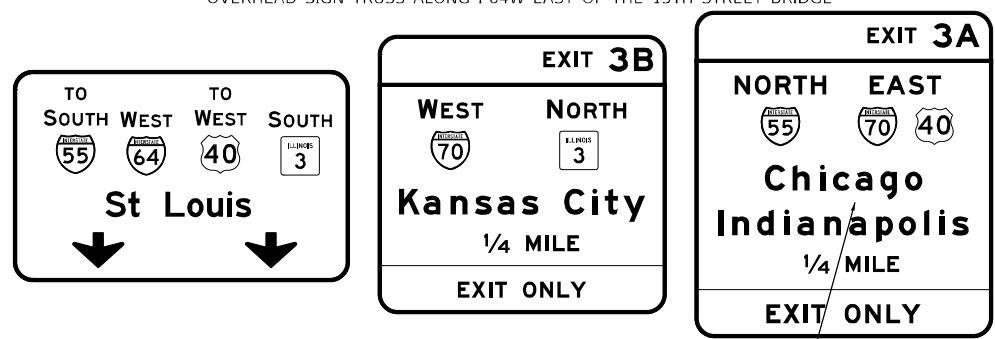

INSTALL CLOSED PLAQUE (ORANGE)

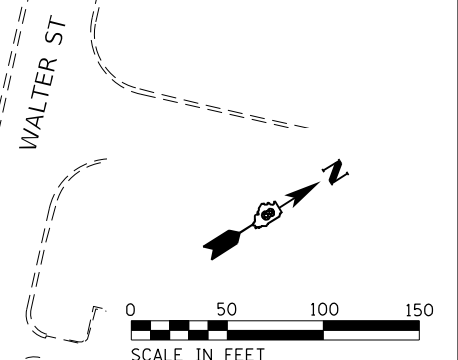

MODEL: 4/24/11
FILE NAME: 211030220_BCO_BR_BridgeDCNDesignFinal\Fiber\Sheet63-D078K02-Sht-Stage 2-14.dwg

EFK Moen
Civil Engineering Design

USER NAME = zWaters	DESIGNED - SJF	REVISED -
PLOT SCALE = 100,0000' / in.	DRAWN - SJF	REVISED -
PLOT DATE = 8/13/2024	CHECKED - SLD	REVISED -
	DATE - 8/13/2024	REVISED -

STATE OF ILLINOIS
DEPARTMENT OF TRANSPORTATION

TRAFFIC CONTROL AND PROTECTION PLAN
STAGE 2

SCALE: 1"=50' SHEET 30 OF 5>TFC SHEETS STA. TO STA.

F.A.I. RTE.	SECTION	COUNTY	TOTAL SHEETS	SHEET NO.
70	82-5V8-R-2	ST. CLAIR	254	64
CONTRACT NO. 76K02				
ILLINOIS FED. AID PROJECT				

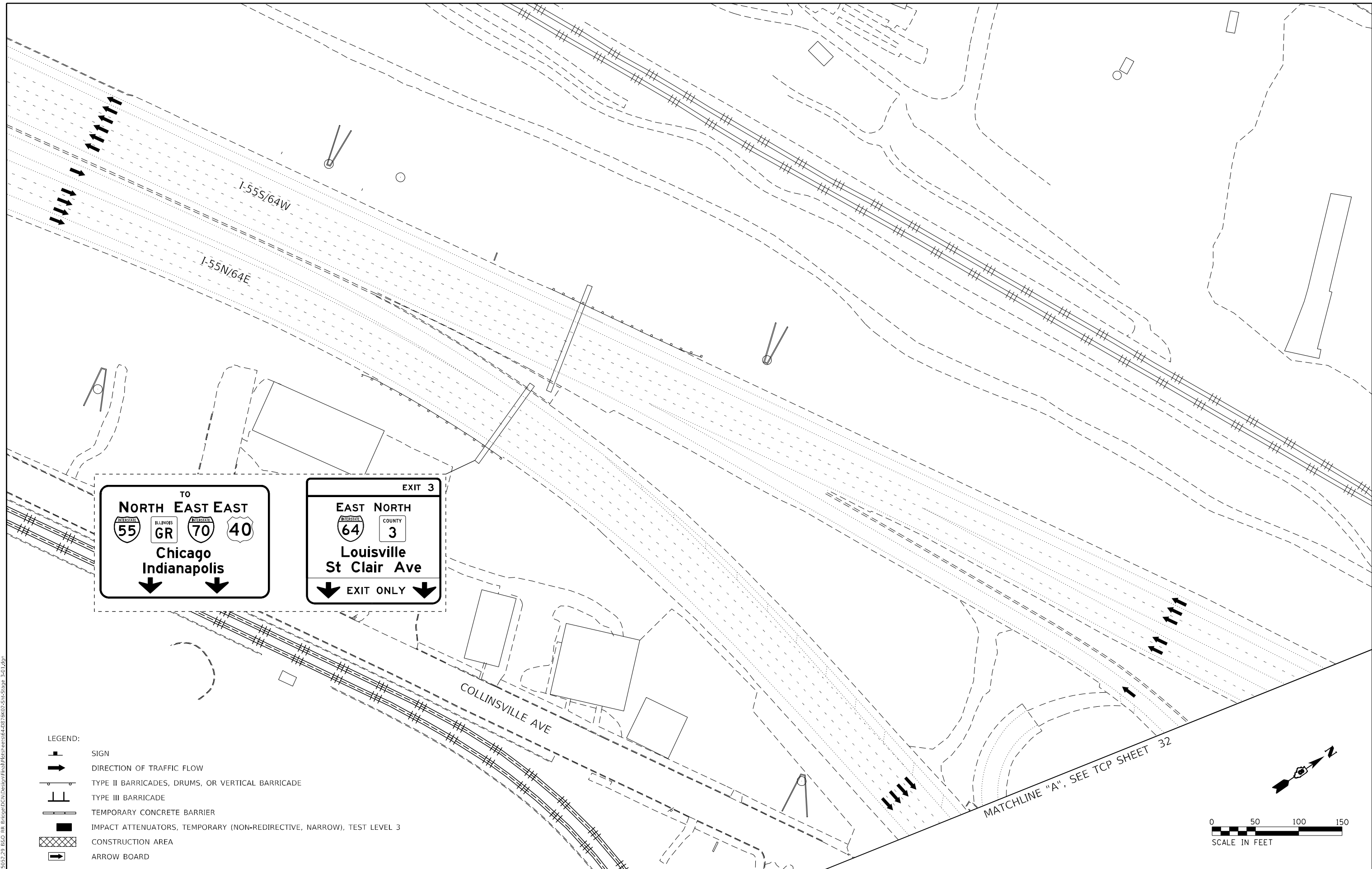

TO
NORTH EAST EAST
 ILLINOIS STATE ROUTE 55 GR ILLINOIS STATE ROUTE 70 40
Chicago Indianapolis

EXIT 3
EAST NORTH
 ILLINOIS STATE ROUTE 64 COUNTY 3
Louisville St Clair Ave
 EXIT ONLY

- LEGEND:**
- SIGN
 - DIRECTION OF TRAFFIC FLOW
 - TYPE II BARRICADES, DRUMS, OR VERTICAL BARRICADE
 - TYPE III BARRICADE
 - TEMPORARY CONCRETE BARRIER
 - IMPACT ATTENUATORS, TEMPORARY (NON-REDIRECTIVE, NARROW), TEST LEVEL 3
 - CONSTRUCTION AREA
 - ARROW BOARD

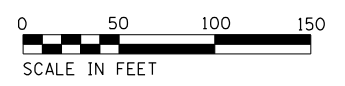

MODEL: 464611
 FILE NAME: Z:\1305229_BEG_BR_Bridge\DCN\Design\Plan\Traffic\82-5V8-R-2\82-5V8-R-2-Stage_3_01.dwg

EFK Moen
 Civil Engineering Design

USER NAME = zWaters	DESIGNED - SJF	REVISED -
PLOT SCALE = 100,0000' / in.	DRAWN - SJF	REVISED -
PLOT DATE = 8/13/2024	CHECKED - SLD	REVISED -
	DATE - 8/13/2024	REVISED -

**STATE OF ILLINOIS
 DEPARTMENT OF TRANSPORTATION**









**TRAFFIC CONTROL AND PROTECTION PLAN
 STAGE 3**

SCALE: 1"=50' SHEET 31 OF 5>TFC SHEETS STA. TO STA.

F.A.I. RTE.	SECTION	COUNTY	TOTAL SHEETS	SHEET NO.
70	82-5V8-R-2	ST. CLAIR	254	65
CONTRACT NO. 76K02				

ILLINOIS FED. AID PROJECT

LEGEND:

-  SIGN
-  DIRECTION OF TRAFFIC FLOW
-  TYPE II BARRICADES, DRUMS, OR VERTICAL BARRICADE
-  TYPE III BARRICADE
-  TEMPORARY CONCRETE BARRIER
-  IMPACT ATTENUATORS, TEMPORARY (NON-REDIRECTIVE, NARROW), TEST LEVEL 3
-  CONSTRUCTION AREA
-  ARROW BOARD

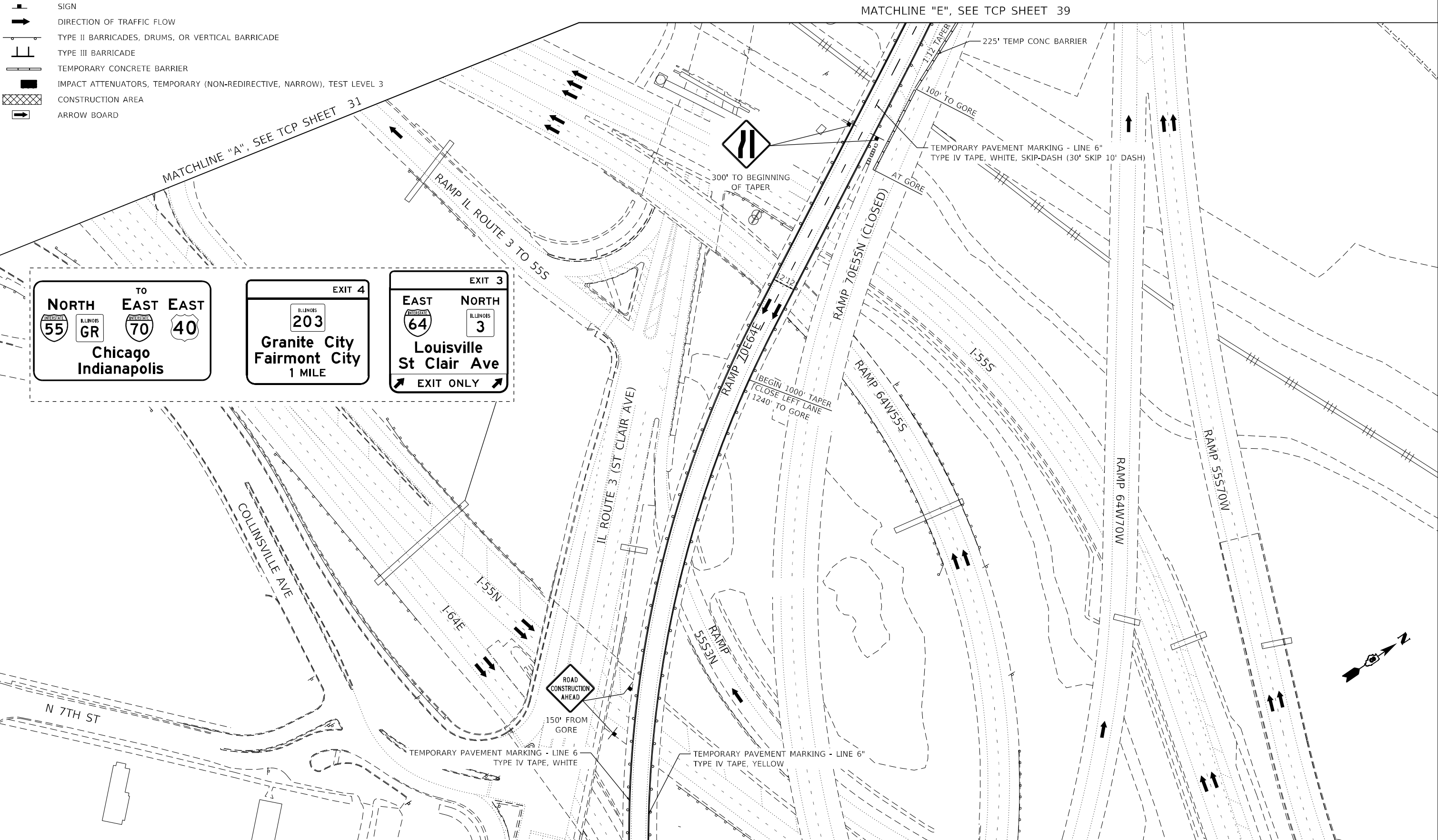

<p>NORTH TO EAST EAST 55 GR 70 40 Chicago Indianapolis</p>	<p>EXIT 4 ILLINOIS 203 Granite City Fairmont City 1 MILE</p>	<p>EXIT 3 EAST NORTH 64 3 Louisville St Clair Ave EXIT ONLY</p>
---	--	---

MODEL: 464611
 FILE NAME: Z:\13052239_B60_BR_B60ge\DC\Design\Plan\Traffic\82-5V8-R-2\82-5V8-R-2-Stage 3-02.dwg
 DATE: 8/13/2024

EFK Moen
Civil Engineering Design

USER NAME = zWaters	DESIGNED - SJF	REVISED -
PLOT SCALE = 100,0000' / in.	DRAWN - SJF	REVISED -
PLOT DATE = 8/13/2024	CHECKED - SLD	REVISED -
	DATE - 8/13/2024	REVISED -

**STATE OF ILLINOIS
DEPARTMENT OF TRANSPORTATION**

**TRAFFIC CONTROL AND PROTECTION PLAN
STAGE 3**

SCALE: 1"=50' SHEET 32 OF 5>TFC SHEETS STA. TO STA.

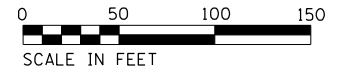

F.A.I. RTE.	SECTION	COUNTY	TOTAL SHEETS	SHEET NO.
70	82-5V8-R-2	ST. CLAIR	254	66
CONTRACT NO. 76K02				
ILLINOIS FED. AID PROJECT				

MATCHLINE "B", SEE TCP SHEET 32

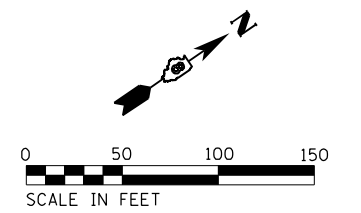
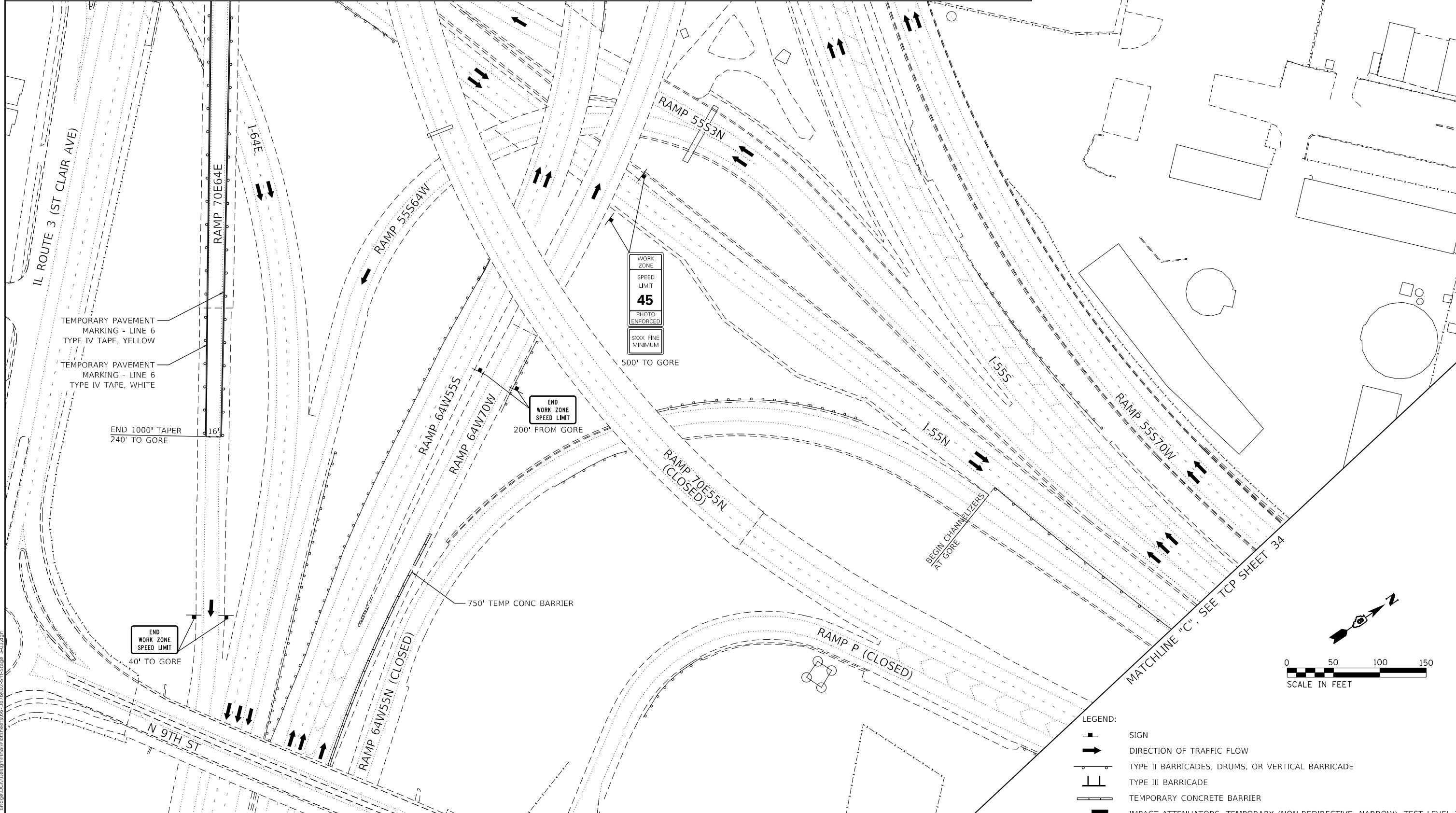

- LEGEND:
- SIGN
 - DIRECTION OF TRAFFIC FLOW
 - TYPE II BARRICADES, DRUMS, OR VERTICAL BARRICADE
 - TYPE III BARRICADE
 - TEMPORARY CONCRETE BARRIER
 - IMPACT ATTENUATORS, TEMPORARY (NON-REDIRECTIVE, NARROW), TEST LEVEL 3
 - CONSTRUCTION AREA
 - ARROW BOARD

MATCHLINE "F", SEE TCP SHEET 40

MODEL: 464611
 FILE NAME: 211305229_B60_BB_BridgeDCNDesign\Final\Revised\650878K02_S34_S34.dwg
 PLOT DATE = 8/13/2024

EFK Moen
Civil Engineering Design

USER NAME = zWaters	DESIGNED - SJF	REVISED -
PLOT SCALE = 100,0000' / in.	DRAWN - SJF	REVISED -
PLOT DATE = 8/13/2024	CHECKED - SLD	REVISED -
	DATE - 8/13/2024	REVISED -

STATE OF ILLINOIS
DEPARTMENT OF TRANSPORTATION

TRAFFIC CONTROL AND PROTECTION PLAN
STAGE 3

SCALE: 1"=50' SHEET 33 OF 5>TFC SHEETS STA. TO STA.

F.A.I. RTE.	SECTION	COUNTY	TOTAL SHEETS	SHEET NO.
70	82-5V8-R-2	ST. CLAIR	254	67
ILLINOIS FED. AID PROJECT			CONTRACT NO. 76K02	

- LEGEND:**
- SIGN
 - DIRECTION OF TRAFFIC FLOW
 - TYPE II BARRICADES, DRUMS, OR VERTICAL BARRICADE
 - TYPE III BARRICADE
 - TEMPORARY CONCRETE BARRIER
 - IMPACT ATTENUATORS, TEMPORARY (NON-REDIRECTIVE, NARROW), TEST LEVEL 3
 - CONSTRUCTION AREA
 - ARROW BOARD

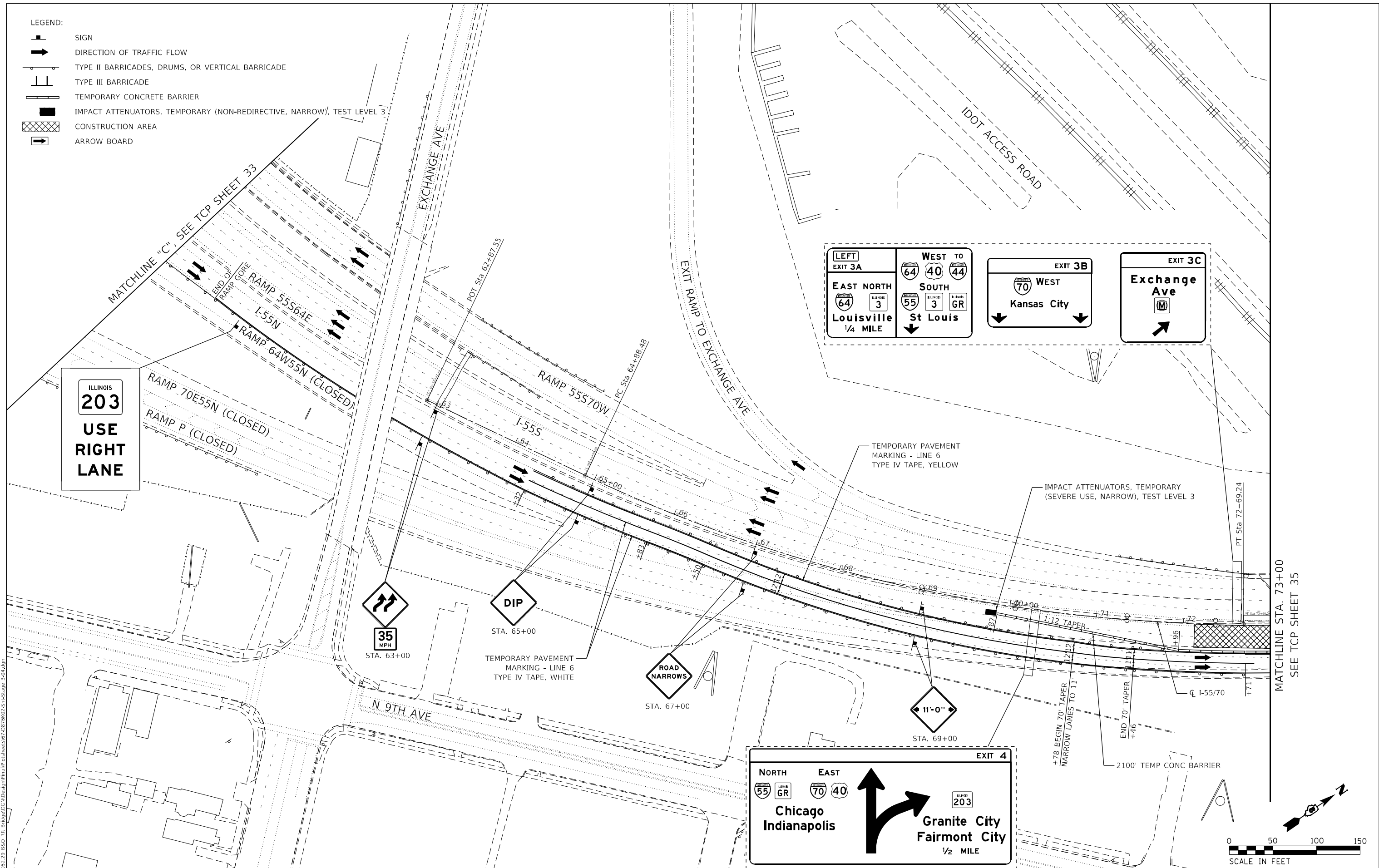

MODEL: 464611
 FILE NAME: Z:\13052239_B60_BR_B6460\DC\Design\Final\Revised\67_D878K02_Sht-Stage_3.dwg
 DATE: 8/13/2024

EFK Moen
Civil Engineering Design









USER NAME = zWaters	DESIGNED - SJF	REVISED -
DRAWN - SJF	REVISED -	
PLOT SCALE = 100,0000' / in.	CHECKED - SLD	REVISED -
PLOT DATE = 8/13/2024	DATE - 8/13/2024	REVISED -

**STATE OF ILLINOIS
DEPARTMENT OF TRANSPORTATION**

**TRAFFIC CONTROL AND PROTECTION PLAN
STAGE 3**

SCALE: 1"=50' SHEET 34 OF 5>TFC SHEETS STA. TO STA. 73+00

F.A.I. RTE.	SECTION	COUNTY	TOTAL SHEETS	SHEET NO.
70	82-5V8-R-2	ST. CLAIR	254	68
CONTRACT NO. 76K02				
ILLINOIS FED. AID PROJECT				

- LEGEND:
-  SIGN
 -  DIRECTION OF TRAFFIC FLOW
 -  TYPE II BARRICADES, DRUMS, OR VERTICAL BARRICADE
 -  TYPE III BARRICADE
 -  TEMPORARY CONCRETE BARRIER
 -  IMPACT ATTENUATORS, TEMPORARY (NON-REDIRECTIVE, NARROW), TEST LEVEL 3
 -  CONSTRUCTION AREA
 -  ARROW BOARD

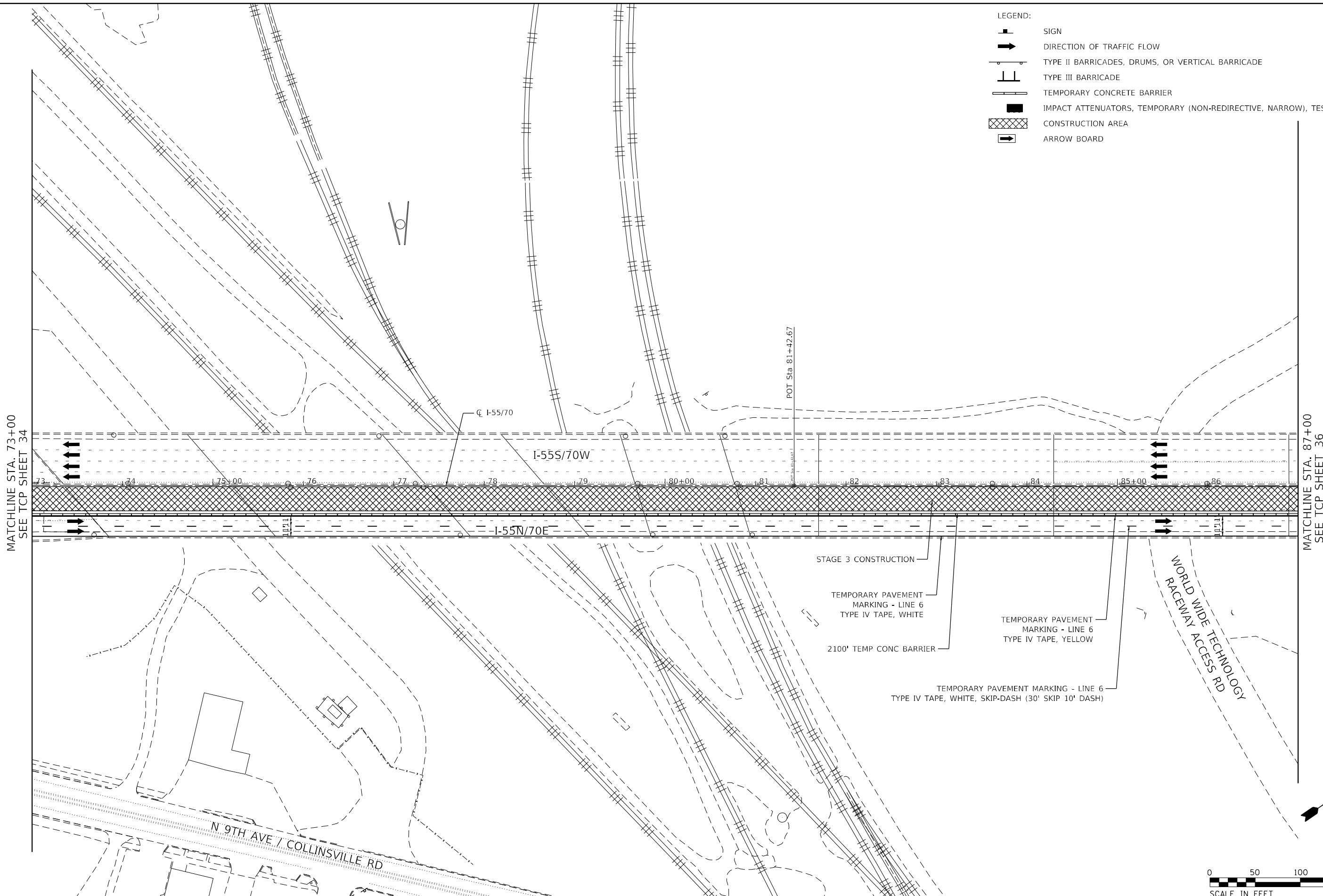

MATCHLINE STA. 73+00
SEE TCP SHEET 34

MATCHLINE STA. 87+00
SEE TCP SHEET 36

MODEL: 464641
FILE NAME: Z:\13052229_B60_BR_Bridge\DC\Design\Final\Revised\82-5V8-R-2\Stage 3_015.dgn

EFK Moen
Civil Engineering Design

USER NAME = zWaters	DESIGNED - SJF	REVISED -
PLOT SCALE = 100,0000' / in.	DRAWN - SJF	REVISED -
PLOT DATE = 8/13/2024	CHECKED - SLD	REVISED -
	DATE - 8/13/2024	REVISED -









STATE OF ILLINOIS
DEPARTMENT OF TRANSPORTATION

TRAFFIC CONTROL AND PROTECTION PLAN
STAGE 3

SCALE: 1"=50' SHEET 35 OF 5>TFC SHEETS STA. 73+00 TO STA. 87+00

F.A.I. RTE.	SECTION	COUNTY	TOTAL SHEETS	SHEET NO.
70	82-5V8-R-2	ST. CLAIR	254	69
CONTRACT NO. 76K02				
ILLINOIS FED. AID PROJECT				

LEGEND:

-  SIGN
-  DIRECTION OF TRAFFIC FLOW
-  TYPE II BARRICADES, DRUMS, OR VERTICAL BARRICADE
-  TYPE III BARRICADE
-  TEMPORARY CONCRETE BARRIER
-  IMPACT ATTENUATORS, TEMPORARY (NON-REDIRECTIVE, NARROW), TEST LEVEL 3
-  CONSTRUCTION AREA
-  ARROW BOARD

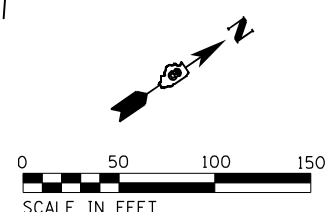
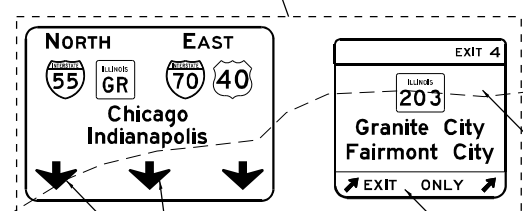
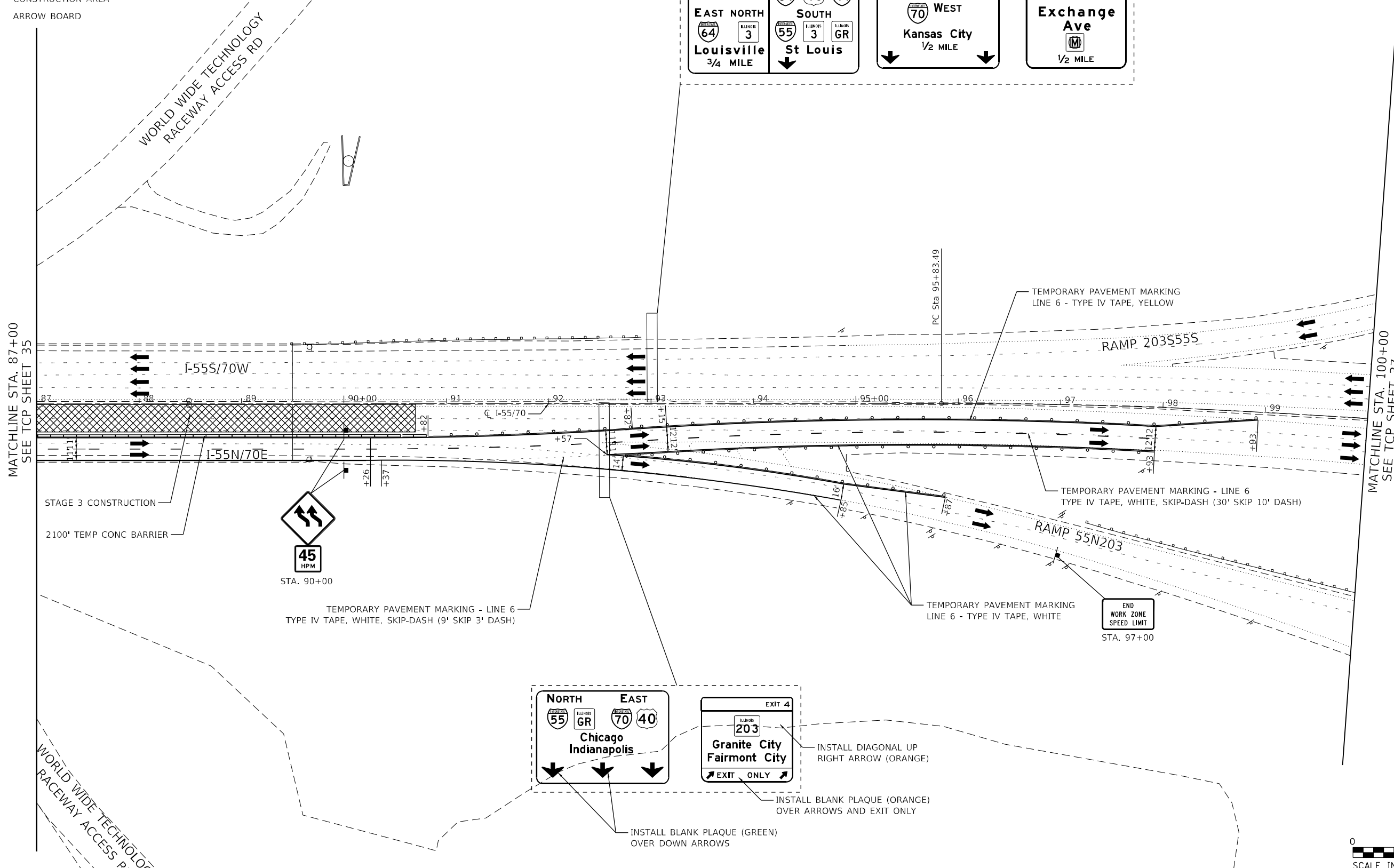
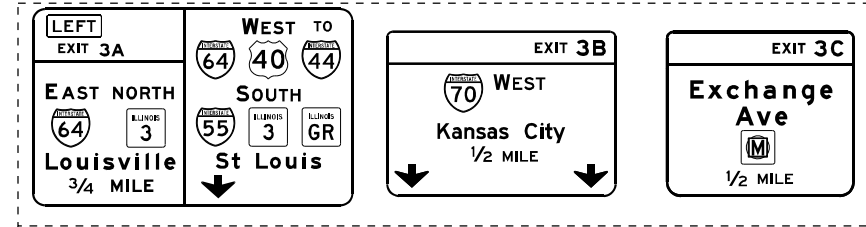

MODEL: 464646
 FILE NAME: Z:\13052229_B60_BR_Bridge\DCN\Design\Final\Fetch\Sheet\82-5V8-R-2-Stage 3-016.dgn

EFK Moen
Civil Engineering Design

USER NAME = zWaters	DESIGNED - SJF	REVISED -
PLOT SCALE = 100,0000' / in.	DRAWN - SJF	REVISED -
PLOT DATE = 8/13/2024	CHECKED - SLD	REVISED -
	DATE - 8/13/2024	REVISED -









**STATE OF ILLINOIS
DEPARTMENT OF TRANSPORTATION**

**TRAFFIC CONTROL AND PROTECTION PLAN
STAGE 3**

SCALE: 1"=50' SHEET 36 OF 5>TFC SHEETS STA. 87+00 TO STA. 100+00

F.A.I. RTE.	SECTION	COUNTY	TOTAL SHEETS	SHEET NO.
70	82-5V8-R-2	ST. CLAIR	254	70
CONTRACT NO. 76K02				
ILLINOIS FED. AID PROJECT				

LEGEND:

-  SIGN
-  DIRECTION OF TRAFFIC FLOW
-  TYPE II BARRICADES, DRUMS, OR VERTICAL BARRICADE
-  TYPE III BARRICADE
-  TEMPORARY CONCRETE BARRIER
-  IMPACT ATTENUATORS, TEMPORARY (NON-REDIRECTIVE, NARROW), TEST LEVEL 3
-  CONSTRUCTION AREA
-  ARROW BOARD

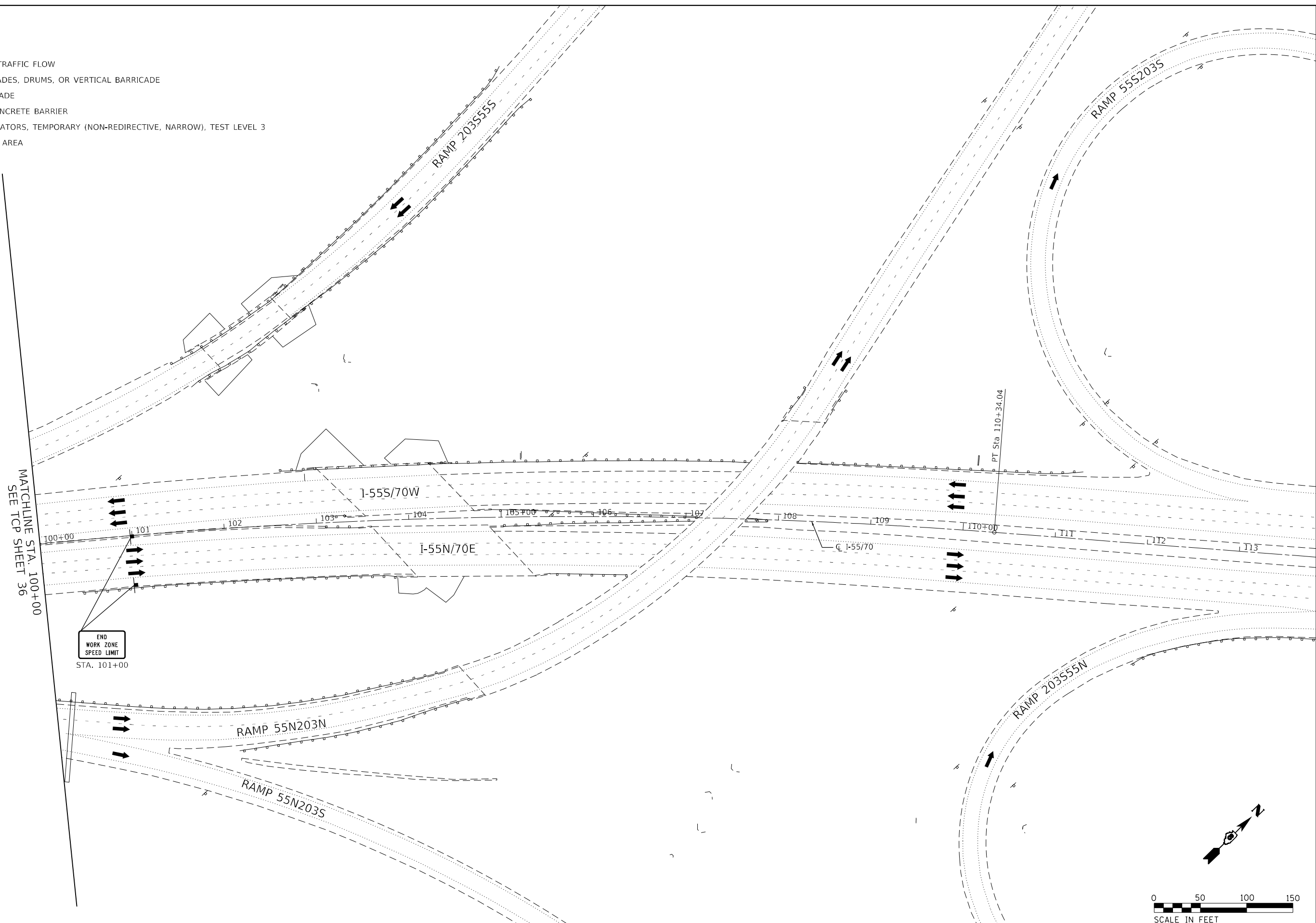

MODEL: d464h
 FILE NAME: Z:\13052-29_B&O_BR_Bridge\DCN\Design\Final\Fiber\Sheet\76K02-Sht-Stage_3.dwg
 DATE: 8/13/2024

EFK Moen
Civil Engineering Design

USER NAME = zWaters	DESIGNED - SJF	REVISED -
DRAWN - SJF	REVISIONS -	
PLOT SCALE = 100,0000' / in.	CHECKED - SLD	REVISIONS -
PLOT DATE = 8/13/2024	DATE - 8/13/2024	REVISIONS -

**STATE OF ILLINOIS
DEPARTMENT OF TRANSPORTATION**

**TRAFFIC CONTROL AND PROTECTION PLAN
STAGE 3**

SCALE: 1"=50' SHEET 37 OF 5>TFC SHEETS STA. 100+00 TO STA. 112+00

F.A.I. RTE.	SECTION	COUNTY	TOTAL SHEETS	SHEET NO.
70	82-5V8-R-2	ST. CLAIR	254	71
CONTRACT NO. 76K02				
ILLINOIS FED. AID PROJECT				

ADVANCED SIGNING ALONG I-70 (WESTBOUND)

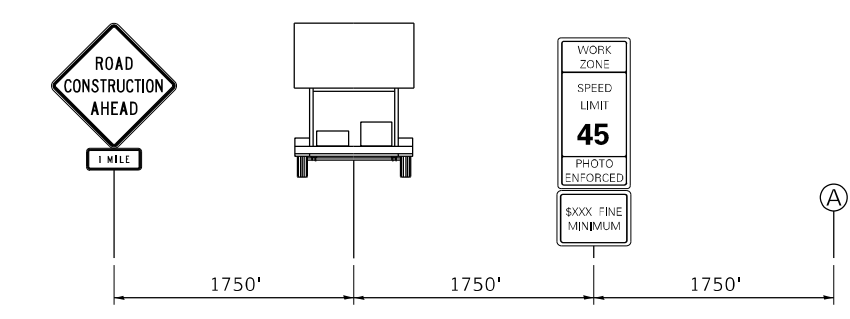

NOTE:
1. ADVANCED WARNING SIGNS SHALL BE PLACED ON EITHER SIDE OF WESTBOUND I-70.

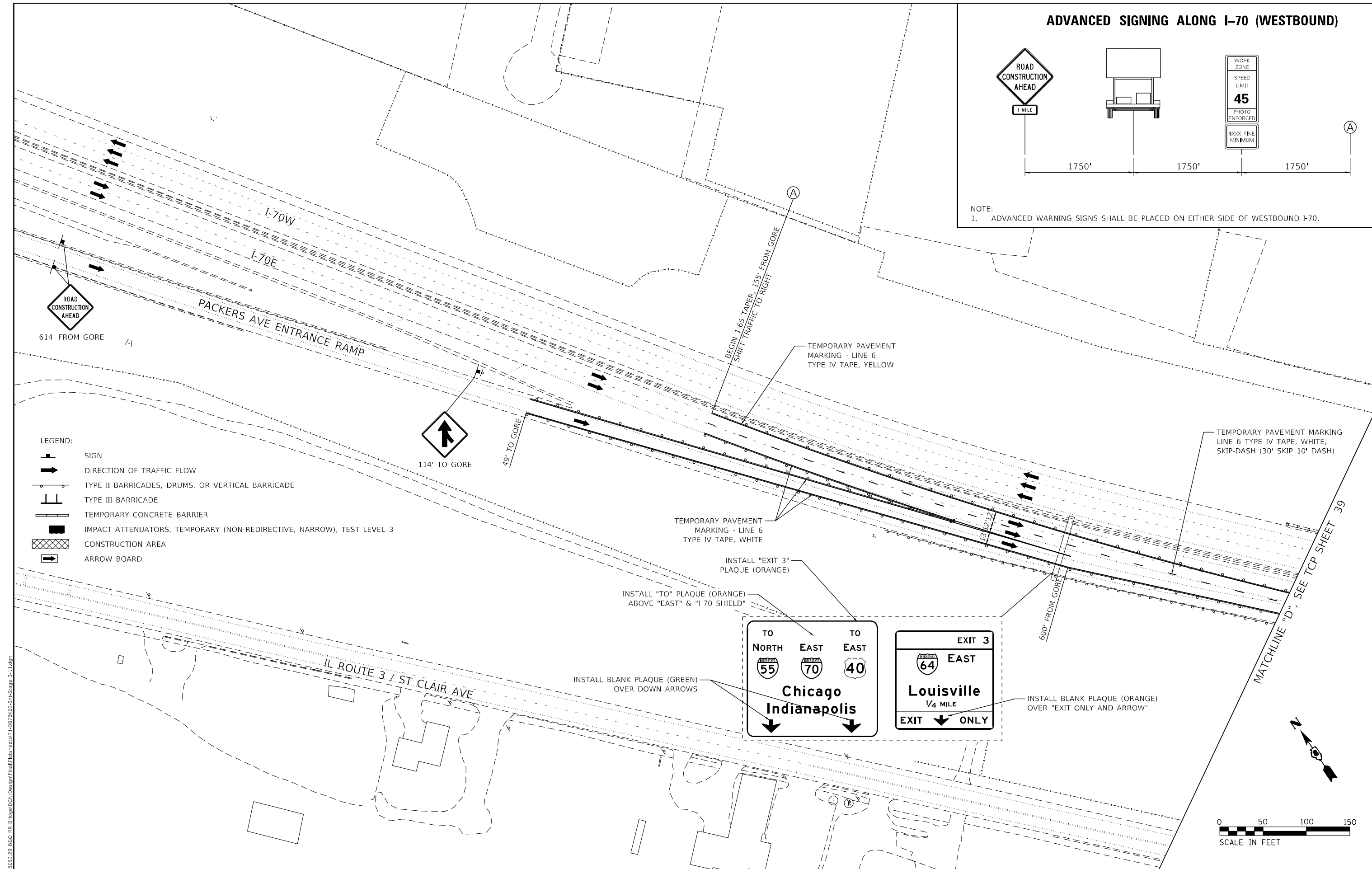

- LEGEND:**
- SIGN
 - DIRECTION OF TRAFFIC FLOW
 - TYPE II BARRICADES, DRUMS, OR VERTICAL BARRICADE
 - TYPE III BARRICADE
 - TEMPORARY CONCRETE BARRIER
 - IMPACT ATTENUATORS, TEMPORARY (NON-REDIRECTIVE, NARROW), TEST LEVEL 3
 - CONSTRUCTION AREA
 - ARROW BOARD

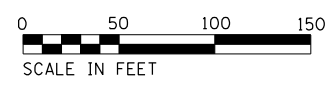
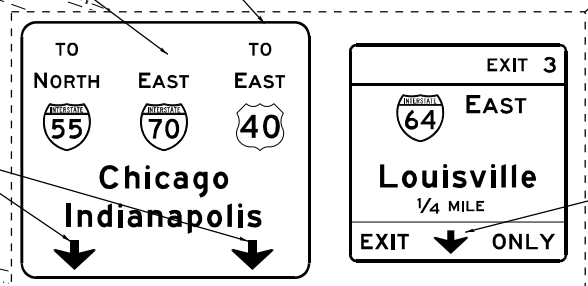

MODEL: 464611
 FILE NAME: 211305229_B60_BR_BridgeDCNDesign\Final\FinalSheet38-1.dgn
 USER: zWaters

EFK Moen
Civil Engineering Design

USER NAME = zWaters	DESIGNED - SJF	REVISED -
PLOT SCALE = 100,0000' / in.	DRAWN - SJF	REVISED -
PLOT DATE = 8/13/2024	CHECKED - SLD	REVISED -
	DATE - 8/13/2024	REVISED -

**STATE OF ILLINOIS
DEPARTMENT OF TRANSPORTATION**

**TRAFFIC CONTROL AND PROTECTION PLAN
STAGE 3**

SCALE: 1"=50' SHEET 38 OF 5>TFC SHEETS STA. TO STA.

F.A.I. RTE.	SECTION	COUNTY	TOTAL SHEETS	SHEET NO.
70	82-5V8-R-2	ST. CLAIR	254	72
CONTRACT NO. 76K02			ILLINOIS FED. AID PROJECT	

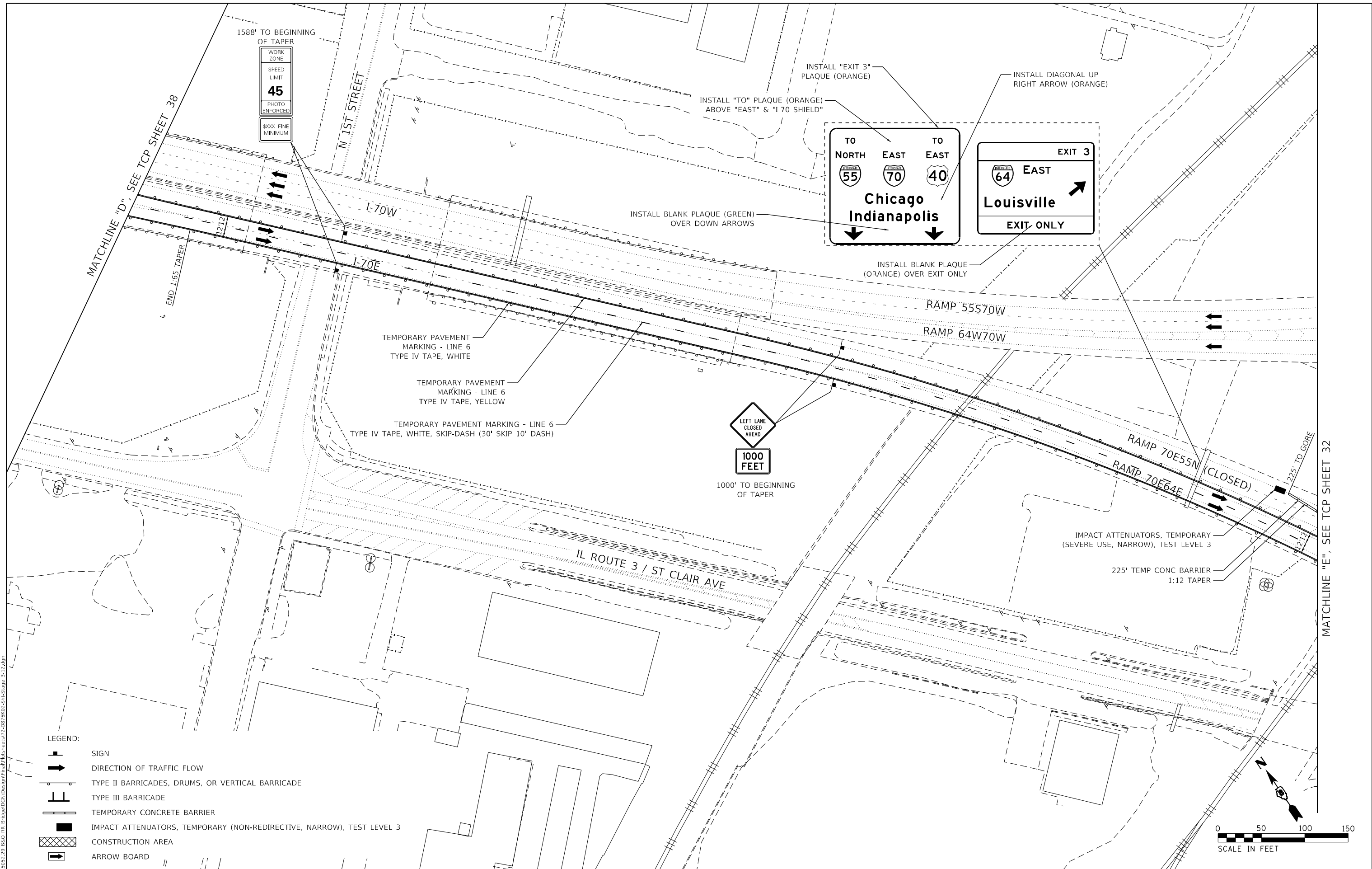

MATCHLINE "D", SEE TCP SHEET 38

1588' TO BEGINNING OF TAPER

WORK ZONE

SPEED LIMIT

45

PHOTO ENFORCED

\$300 FINE MINIMUM

N 1ST STREET

INSTALL "EXIT 3" PLAQUE (ORANGE)

INSTALL DIAGONAL UP RIGHT ARROW (ORANGE)

INSTALL "TO" PLAQUE (ORANGE) ABOVE "EAST" & "I-70 SHIELD"

TO NORTH **55** TO EAST **70** TO EAST **40**

Chicago Indianapolis

EXIT 3

64 EAST

Louisville

EXIT ONLY

INSTALL BLANK PLAQUE (GREEN) OVER DOWN ARROWS

INSTALL BLANK PLAQUE (ORANGE) OVER EXIT ONLY

TEMPORARY PAVEMENT MARKING - LINE 6 TYPE IV TAPE, WHITE

TEMPORARY PAVEMENT MARKING - LINE 6 TYPE IV TAPE, YELLOW

TEMPORARY PAVEMENT MARKING - LINE 6 TYPE IV TAPE, WHITE, SKIP-DASH (30' SKIP 10' DASH)

LEFT LANE CLOSED AHEAD

1000 FEET

1000' TO BEGINNING OF TAPER

RAMP 55S70W

RAMP 64W70W

RAMP 70E55N (CLOSED)

RAMP 70E64E

IL ROUTE 3 / ST CLAIR AVE

IMPACT ATTENUATORS, TEMPORARY (SEVERE USE, NARROW), TEST LEVEL 3

225' TEMP CONC BARRIER 1:12 TAPER

MATCHLINE "E", SEE TCP SHEET 32

LEGEND:

- SIGN
- DIRECTION OF TRAFFIC FLOW
- TYPE II BARRICADES, DRUMS, OR VERTICAL BARRICADE
- TYPE III BARRICADE
- TEMPORARY CONCRETE BARRIER
- IMPACT ATTENUATORS, TEMPORARY (NON-REDIRECTIVE, NARROW), TEST LEVEL 3
- CONSTRUCTION AREA
- ARROW BOARD

MODEL: 464611
FILE NAME: 2113052239_B60_BR_BridgeDCNDesignPlanSheet172.D876K02-Stk-Stage_3-12.dwg

EFK Moen
Civil Engineering Design

USER NAME = zWaters

DESIGNED - SJF

DRAWN - SJF

REVISOR - SLD

CHECKED - SLD

DATE - 8/13/2024

REVISIONS:

REVISIONS	NO.	DESCRIPTION

STATE OF ILLINOIS
DEPARTMENT OF TRANSPORTATION

TRAFFIC CONTROL AND PROTECTION PLAN
STAGE 3

SCALE: 1"=50' SHEET 39 OF 5>TFC SHEETS STA. TO STA.

F.A.I. RTE.	SECTION	COUNTY	TOTAL SHEETS	SHEET NO.
70	82-5V8-R-2	ST. CLAIR	254	73
CONTRACT NO. 76K02			ILLINOIS FED. AID PROJECT	

MATCHLINE "F", SEE TCP SHEET 33

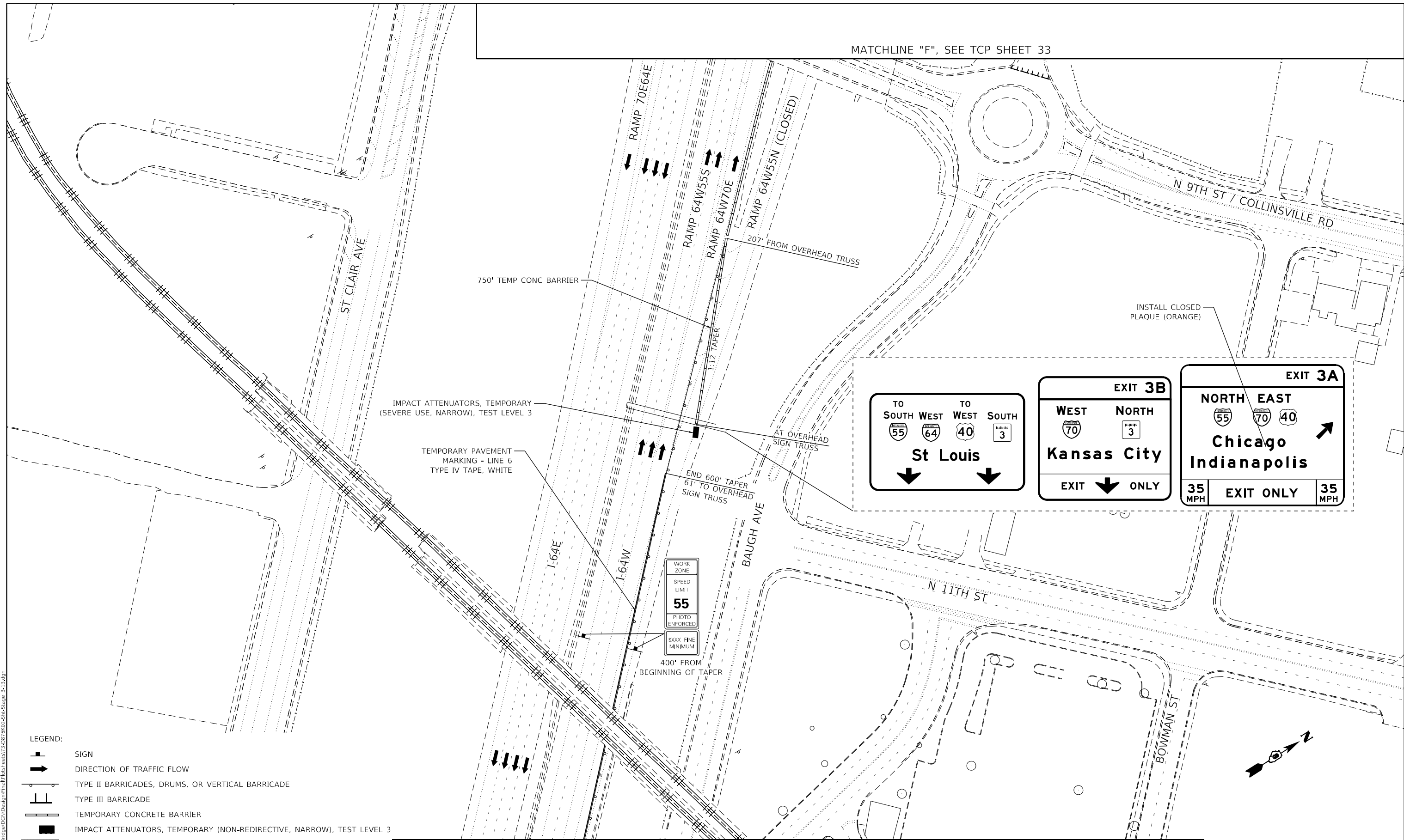

MATCHLINE "G", SEE TCP SHEET 41

- LEGEND:
- SIGN
 - DIRECTION OF TRAFFIC FLOW
 - TYPE II BARRICADES, DRUMS, OR VERTICAL BARRICADE
 - TYPE III BARRICADE
 - TEMPORARY CONCRETE BARRIER
 - IMPACT ATTENUATORS, TEMPORARY (NON-REDIRECTIVE, NARROW), TEST LEVEL 3
 - CONSTRUCTION AREA
 - ARROW BOARD

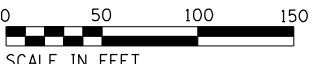
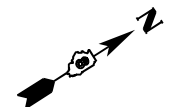

MODEL: 464611
 FILE NAME: 211305229_B60_BR_BridgeDCNDesignFinalRevised173-0878K02-Sub-Stage_3-13.dgn

EFK Moen
Civil Engineering Design

USER NAME = zWaters	DESIGNED - SJF	REVISED -
PLOT SCALE = 100,0000' / in.	DRAWN - SJF	REVISED -
PLOT DATE = 8/13/2024	CHECKED - SLD	REVISED -
	DATE - 8/13/2024	REVISED -

STATE OF ILLINOIS
DEPARTMENT OF TRANSPORTATION

TRAFFIC CONTROL AND PROTECTION PLAN
STAGE 3

SCALE: 1"=50' SHEET 40 OF 5>TFC SHEETS STA. TO STA.

F.A.I. RTE.	SECTION	COUNTY	TOTAL SHEETS	SHEET NO.
70	82-5V8-R-2	ST. CLAIR	254	74
CONTRACT NO. 76K02				
ILLINOIS FED. AID PROJECT				

LEGEND:

- SIGN
- DIRECTION OF TRAFFIC FLOW
- TYPE II BARRICADES, DRUMS, OR VERTICAL BARRICADE
- TYPE III BARRICADE
- TEMPORARY CONCRETE BARRIER
- IMPACT ATTENUATORS, TEMPORARY (NON-REDIRECTIVE, NARROW), TEST LEVEL 3
- CONSTRUCTION AREA
- ARROW BOARD

TEMPORARY PAVEMENT MARKING - LINE 6
TYPE IV TAPE, WHITE

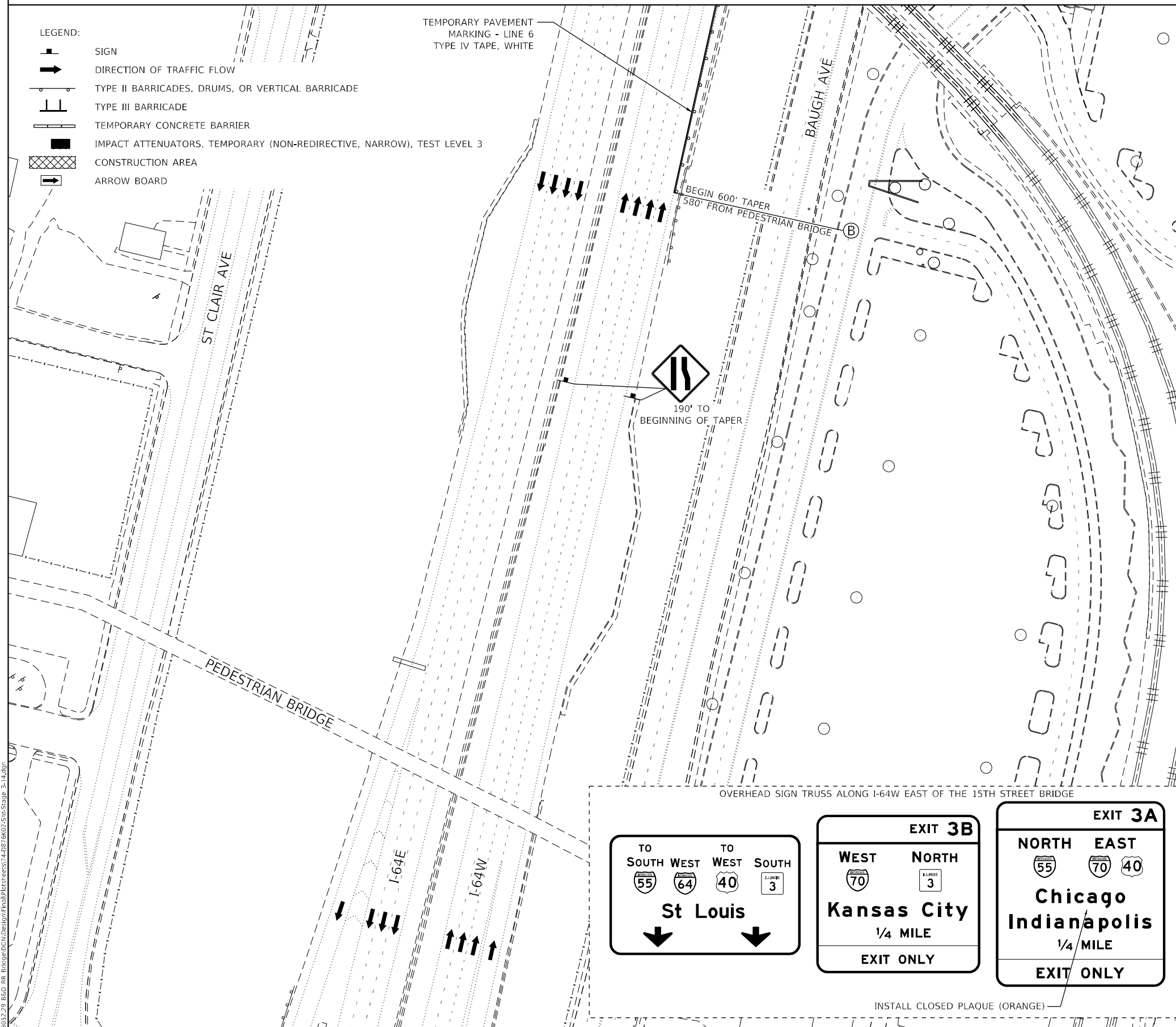

ADVANCED SIGNING ALONG I-64 (WESTBOUND)

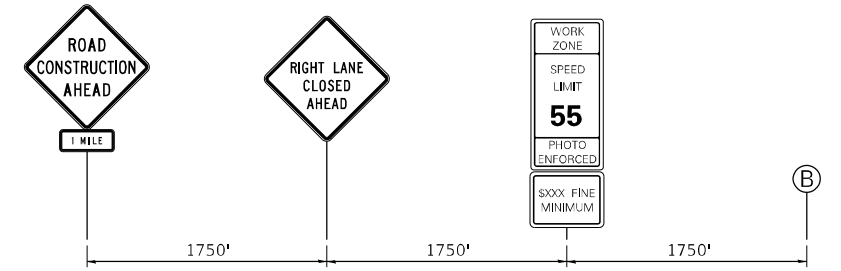

NOTE:
1. ALL ADVANCED WARNING SIGNS SHALL BE PLACED ON EITHER SIDE OF WESTBOUND I-64.

**ADVANCED SIGNING ALONG BAUGH AVE
ENTRANCE RAMP TO I-64W**

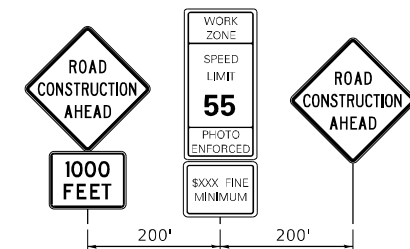

NOTE:
1. ALL ADVANCED WARNING SIGNS SHALL BE PLACED ON EITHER SIDE OF THE RAMP.

**ADVANCED SIGNING ALONG 25TH ST
ENTRANCE RAMP TO I-64W**

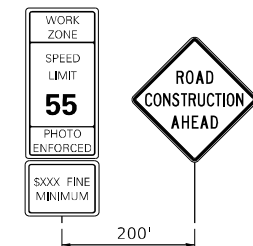

NOTE:
1. ALL ADVANCED WARNING SIGNS SHALL BE PLACED ON EITHER SIDE OF THE RAMP.

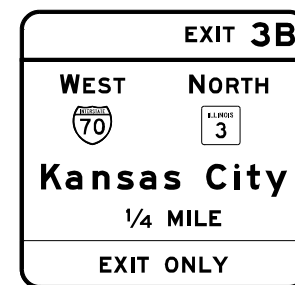
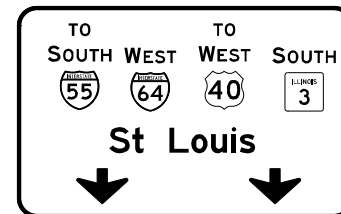

INSTALL CLOSED PLAQUE (ORANGE)

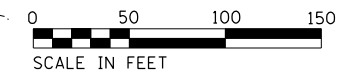

MODEL: 464611
FILE NAME: 211030220_B60_BR_BridgeDesignFinalRevised74.DWG
DATE: 8/13/2024

EFK Moen
Civil Engineering Design

USER NAME = zWaters	DESIGNED - SJF	REVISED -
PLOT SCALE = 100,000' / in.	DRAWN - SJF	REVISED -
PLOT DATE = 8/13/2024	CHECKED - SLD	REVISED -
	DATE - 8/13/2024	REVISED -

STATE OF ILLINOIS
DEPARTMENT OF TRANSPORTATION

TRAFFIC CONTROL AND PROTECTION PLAN
STAGE 3

SCALE: 1"=50' SHEET 41 OF 5>TFC SHEETS STA. TO STA.

F.A.I. RTE.	SECTION	COUNTY	TOTAL SHEETS	SHEET NO.
70	82-5V8-R-2	ST. CLAIR	254	75
ILLINOIS FED. AID PROJECT			CONTRACT NO. 76K02	

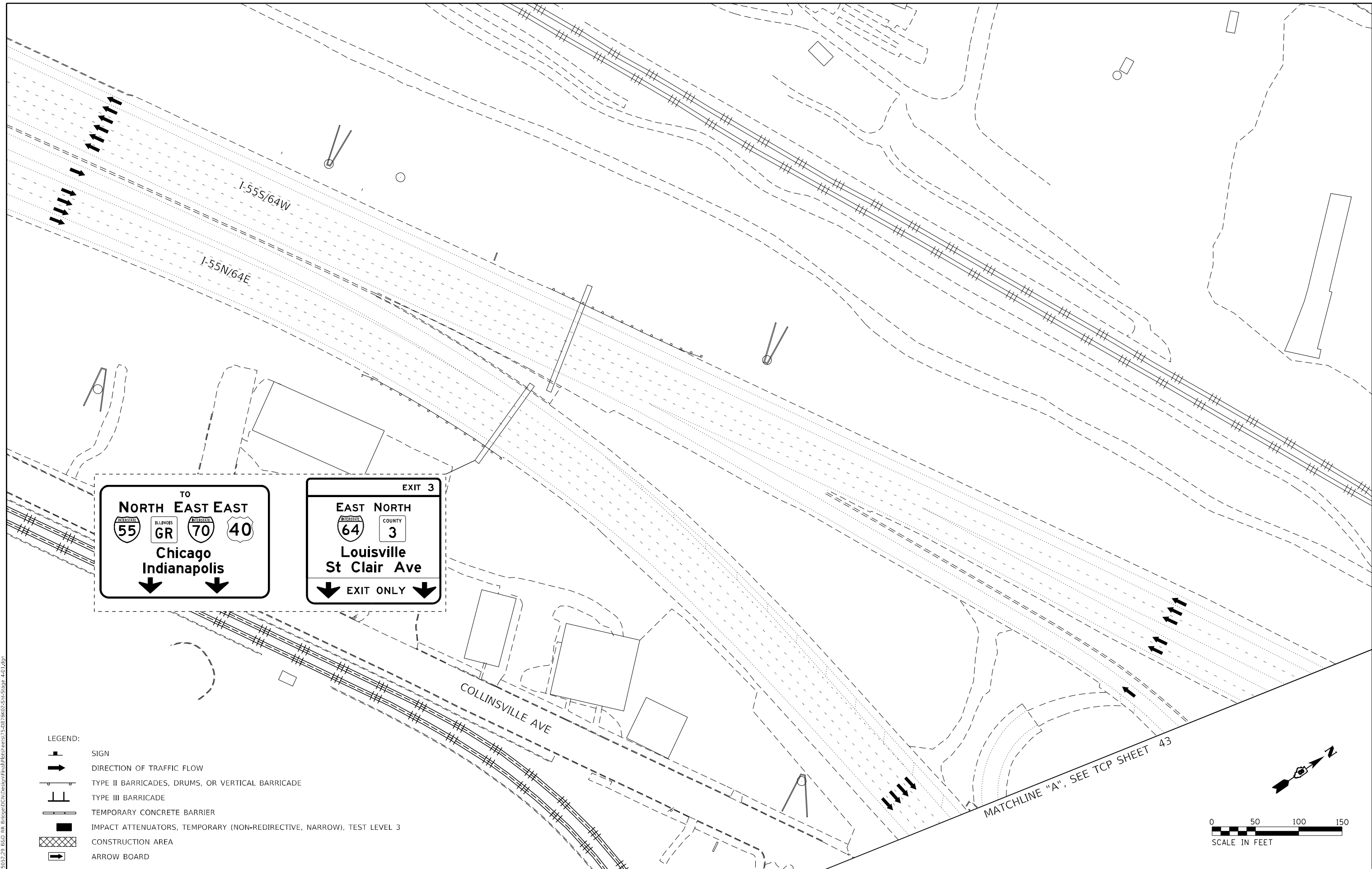

TO
NORTH EAST EAST
 ILLINOIS STATE ROUTE 55 GR ILLINOIS STATE ROUTE 70 40
Chicago Indianapolis

EXIT 3
EAST NORTH
 ILLINOIS STATE ROUTE 64 COUNTY 3
Louisville St Clair Ave
 EXIT ONLY

- LEGEND:
- SIGN
 - DIRECTION OF TRAFFIC FLOW
 - TYPE II BARRICADES, DRUMS, OR VERTICAL BARRICADE
 - TYPE III BARRICADE
 - TEMPORARY CONCRETE BARRIER
 - IMPACT ATTENUATORS, TEMPORARY (NON-REDIRECTIVE, NARROW), TEST LEVEL 3
 - CONSTRUCTION AREA
 - ARROW BOARD



MODEL: 464611
 FILE NAME: Z:\1505229_B60_BR_Bridge\DCN\Design\Plan\Traffic\75-D876K02-Sub-Stage_4.dwg

EFK Moen
 Civil Engineering Design

USER NAME = zWaters	DESIGNED - SJF	REVISED -
PLOT SCALE = 100,0000' / in.	DRAWN - SJF	REVISED -
PLOT DATE = 8/13/2024	CHECKED - SLD	REVISED -
	DATE - 8/13/2024	REVISED -









STATE OF ILLINOIS
DEPARTMENT OF TRANSPORTATION

TRAFFIC CONTROL AND PROTECTION PLAN
STAGE 4

SCALE: 1"=50' SHEET 42 OF 5>TFC SHEETS STA. TO STA.

F.A.I. RTE.	SECTION	COUNTY	TOTAL SHEETS	SHEET NO.
70	82-5V8-R-2	ST. CLAIR	254	76
CONTRACT NO. 76K02				
ILLINOIS FED. AID PROJECT				

LEGEND:

-  SIGN
-  DIRECTION OF TRAFFIC FLOW
-  TYPE II BARRICADES, DRUMS, OR VERTICAL BARRICADE
-  TYPE III BARRICADE
-  TEMPORARY CONCRETE BARRIER
-  IMPACT ATTENUATORS, TEMPORARY (NON-REDIRECTIVE, NARROW), TEST LEVEL 3
-  CONSTRUCTION AREA
-  ARROW BOARD

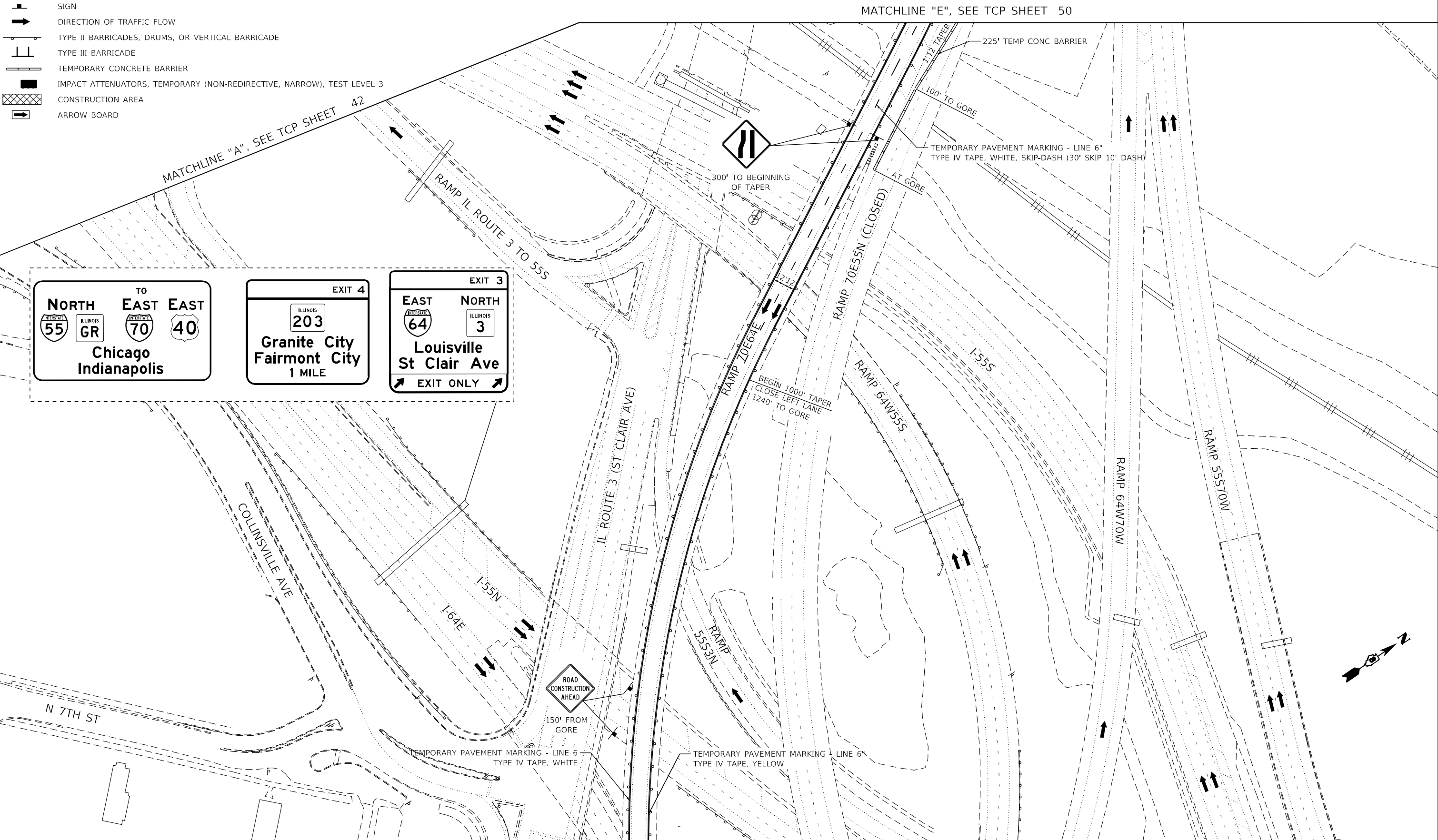

MATCHLINE "A", SEE TCP SHEET 42

MATCHLINE "E", SEE TCP SHEET 50

MATCHLINE "B", SEE TCP SHEET 44

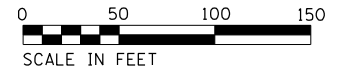

MODEL: 464611
 FILE NAME: Z:\13052.29_BCO_BR_Bldg\DC\Design\Final\Revised\75.0878K02.Sta-Stage 4.dwg
 USER NAME = zWaters

EFK Moen
Civil Engineering Design

DESIGNED - SJF	REVISD -
DRAWN - SJF	REVISD -
CHECKED - SLD	REVISD -
DATE - 8/13/2024	REVISD -

USER NAME = zWaters
PLOT SCALE = 100,000' / in.
PLOT DATE = 8/13/2024

STATE OF ILLINOIS
DEPARTMENT OF TRANSPORTATION

TRAFFIC CONTROL AND PROTECTION PLAN
STAGE 4

SCALE: 1"=50' SHEET 43 OF 5>TFC SHEETS STA. TO STA.

F.A.I. RTE.	SECTION	COUNTY	TOTAL SHEETS	SHEET NO.
70	82-5V8-R-2	ST. CLAIR	254	77
CONTRACT NO. 76K02				
ILLINOIS FED. AID PROJECT				

MATCHLINE "B", SEE TCP SHEET 43

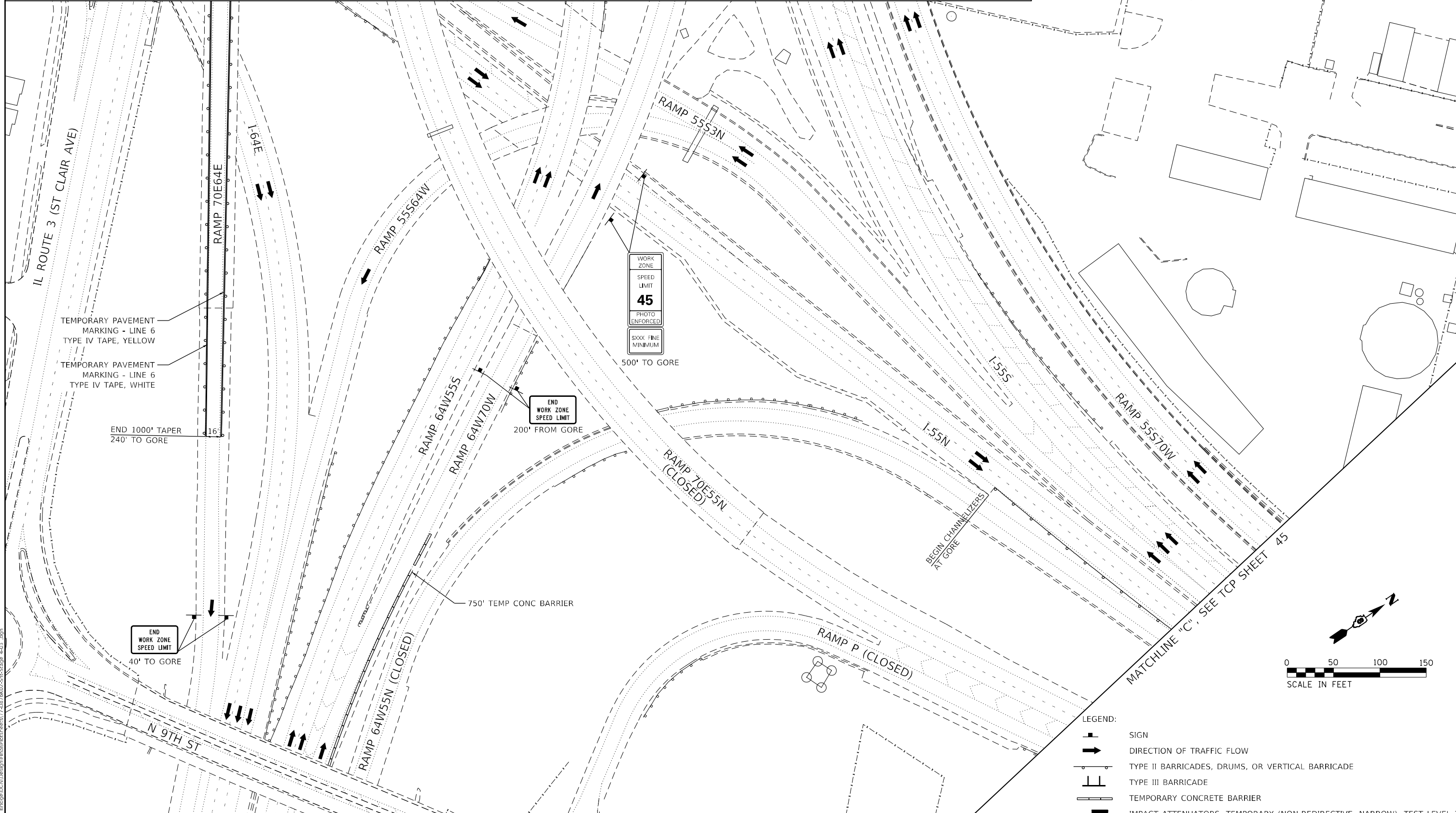

MATCHLINE "F", SEE TCP SHEET 51

- LEGEND:**
- SIGN
 - DIRECTION OF TRAFFIC FLOW
 - TYPE II BARRICADES, DRUMS, OR VERTICAL BARRICADE
 - TYPE III BARRICADE
 - TEMPORARY CONCRETE BARRIER
 - IMPACT ATTENUATORS, TEMPORARY (NON-REDIRECTIVE, NARROW), TEST LEVEL 3
 - CONSTRUCTION AREA
 - ARROW BOARD

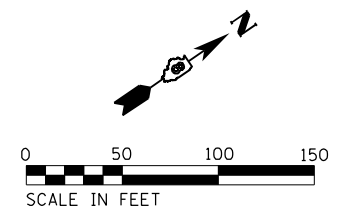

MODEL: 464641
 FILE NAME: Z:\13052.29 B60 BR Bridge\DCN\Design\Final\Revised\70E64W-Side-Stage-4.dgn
 PLOT SCALE = 100,0000' / in.
 PLOT DATE = 8/13/2024

EFK Moen
Civil Engineering Design

USER NAME = zWaters	DESIGNED - SJF	REVISED -
DRAWN - SJF	REVISIONS -	
CHECKED - SLD	REVISIONS -	
DATE - 8/13/2024	REVISIONS -	

**STATE OF ILLINOIS
DEPARTMENT OF TRANSPORTATION**

**TRAFFIC CONTROL AND PROTECTION PLAN
STAGE 4**

SCALE: 1"=50' SHEET 44 OF 5>TFC SHEETS STA. TO STA.

F.A.I. RTE.	SECTION	COUNTY	TOTAL SHEETS	SHEET NO.
70	82-5V8-R-2	ST. CLAIR	254	78
CONTRACT NO. 76K02				
ILLINOIS FED. AID PROJECT				

- LEGEND:**
- SIGN
 - DIRECTION OF TRAFFIC FLOW
 - TYPE II BARRICADES, DRUMS, OR VERTICAL BARRICADE
 - TYPE III BARRICADE
 - TEMPORARY CONCRETE BARRIER
 - IMPACT ATTENUATORS, TEMPORARY (NON-REDIRECTIVE, NARROW), TEST LEVEL 3
 - CONSTRUCTION AREA
 - ARROW BOARD

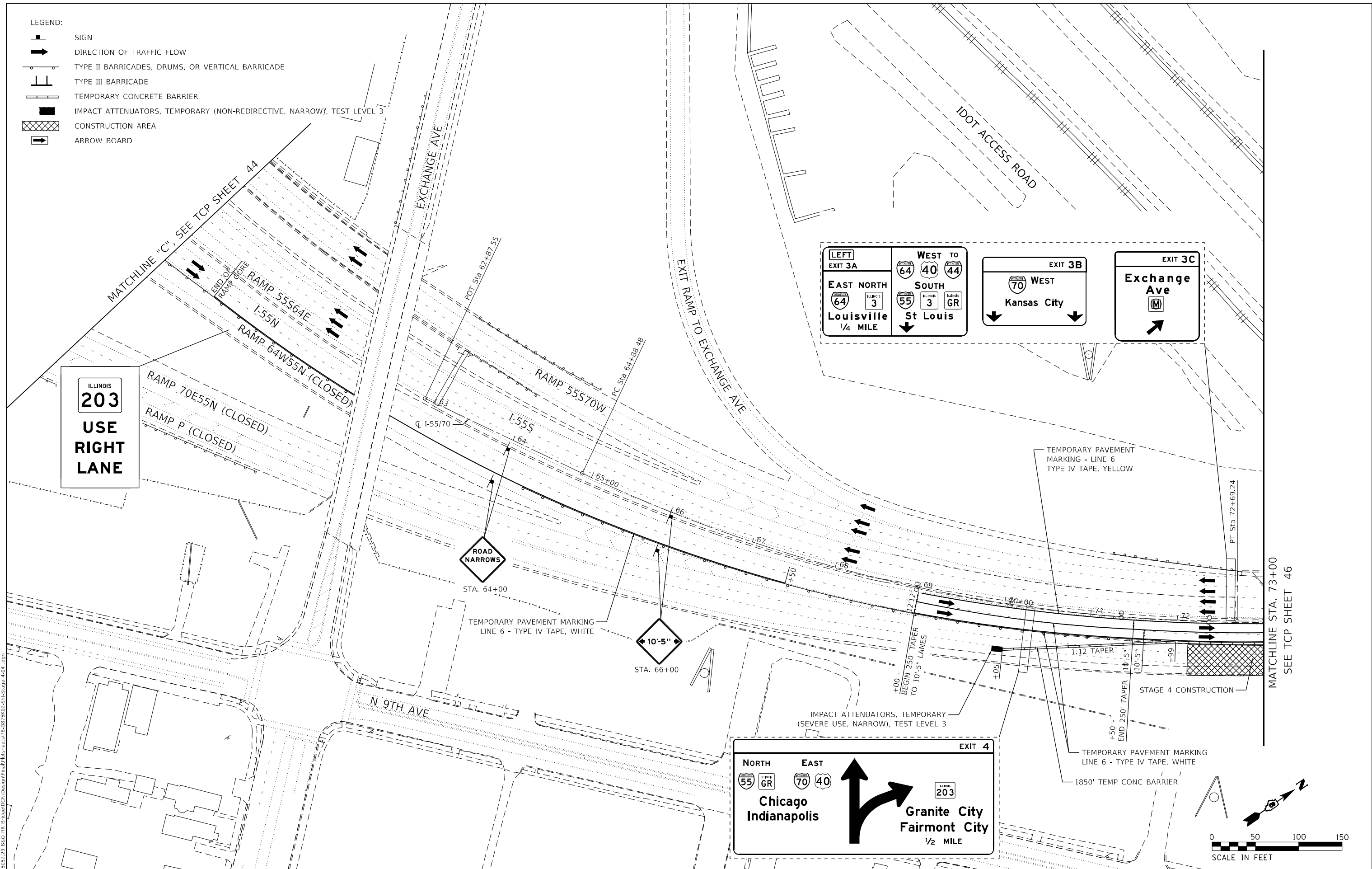

ILLINOIS
203
USE
RIGHT
LANE

LEFT EXIT 3A	WEST TO EXIT 3B	EXIT 3C

EXIT 4

NORTH EXIT 55 GR	EAST EXIT 70 40	EXIT 203
Chicago Indianapolis		Granite City Fairmont City
1/2 MILE		

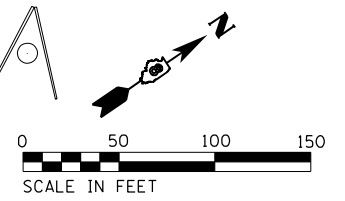

MODEL: 464611
 FILE NAME: Z:\13052-29_B60_BR_B6460\DC\Design\Plan\Refer\Sheet\76K02-5V8-R-2.dwg
 MODEL: 464611
 FILE NAME: Z:\13052-29_B60_BR_B6460\DC\Design\Plan\Refer\Sheet\76K02-5V8-R-2.dwg

EFK Moen
Civil Engineering Design









USER NAME = zWaters	DESIGNED - SJF	REVISED -
PLOT SCALE = 100,0000' / in.	DRAWN - SJF	REVISED -
PLOT DATE = 8/13/2024	CHECKED - SLD	REVISED -
	DATE - 8/13/2024	REVISED -

STATE OF ILLINOIS
DEPARTMENT OF TRANSPORTATION

TRAFFIC CONTROL AND PROTECTION PLAN
STAGE 4

SCALE: 1"=50' SHEET 45 OF 5>TFC SHEETS STA. 62+87.55 TO STA. 73+00

F.A.I. RTE.	SECTION	COUNTY	TOTAL SHEETS	SHEET NO.
70	82-5V8-R-2	ST. CLAIR	254	79
CONTRACT NO. 76K02				
ILLINOIS FED. AID PROJECT				

- LEGEND:
-  SIGN
 -  DIRECTION OF TRAFFIC FLOW
 -  TYPE II BARRICADES, DRUMS, OR VERTICAL BARRICADE
 -  TYPE III BARRICADE
 -  TEMPORARY CONCRETE BARRIER
 -  IMPACT ATTENUATORS, TEMPORARY (NON-REDIRECTIVE, NARROW), TEST LEVEL 3
 -  CONSTRUCTION AREA
 -  ARROW BOARD

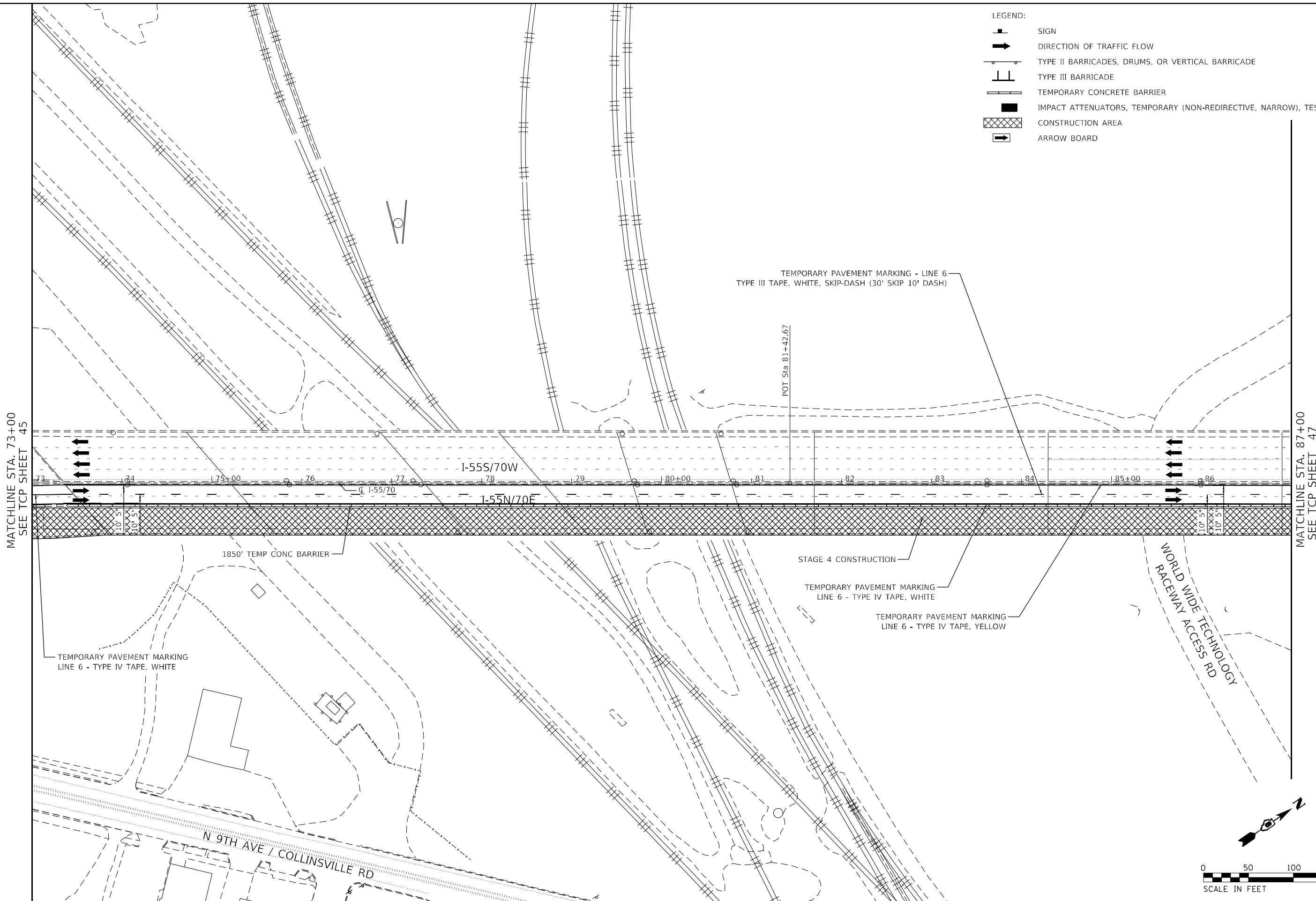

MATCHLINE STA. 73+00
SEE TCP SHEET 45

MATCHLINE STA. 87+00
SEE TCP SHEET 47

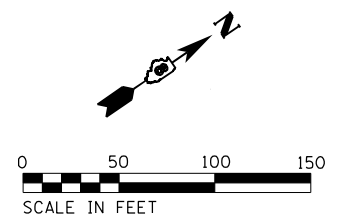

MODEL: 4646.rvt
 FILE NAME: Z:\13052229_B60_BR_Bridge\DC\Design\Plan\Traffic\76K02-Sub-Stage_4.dwg

EFK Moen
Civil Engineering Design

USER NAME = zWaters	DESIGNED - SJF	REVISED -
PLOT SCALE = 100,0000' / in.	DRAWN - SJF	REVISED -
PLOT DATE = 8/13/2024	CHECKED - SLD	REVISED -
	DATE - 8/13/2024	REVISED -









**STATE OF ILLINOIS
DEPARTMENT OF TRANSPORTATION**

**TRAFFIC CONTROL AND PROTECTION PLAN
STAGE 4**

SCALE: 1"=50' SHEET 46 OF 5>TFC SHEETS STA. 73+00 TO STA. 87+00

F.A.I. RTE.	SECTION	COUNTY	TOTAL SHEETS	SHEET NO.
70	82-5V8-R-2	ST. CLAIR	254	80
CONTRACT NO. 76K02				
ILLINOIS FED. AID PROJECT				

LEGEND:

-  SIGN
-  DIRECTION OF TRAFFIC FLOW
-  TYPE II BARRICADES, DRUMS, OR VERTICAL BARRICADE
-  TYPE III BARRICADE
-  TEMPORARY CONCRETE BARRIER
-  IMPACT ATTENUATORS, TEMPORARY (NON-REDIRECTIVE, NARROW), TEST LEVEL 3
-  CONSTRUCTION AREA
-  ARROW BOARD

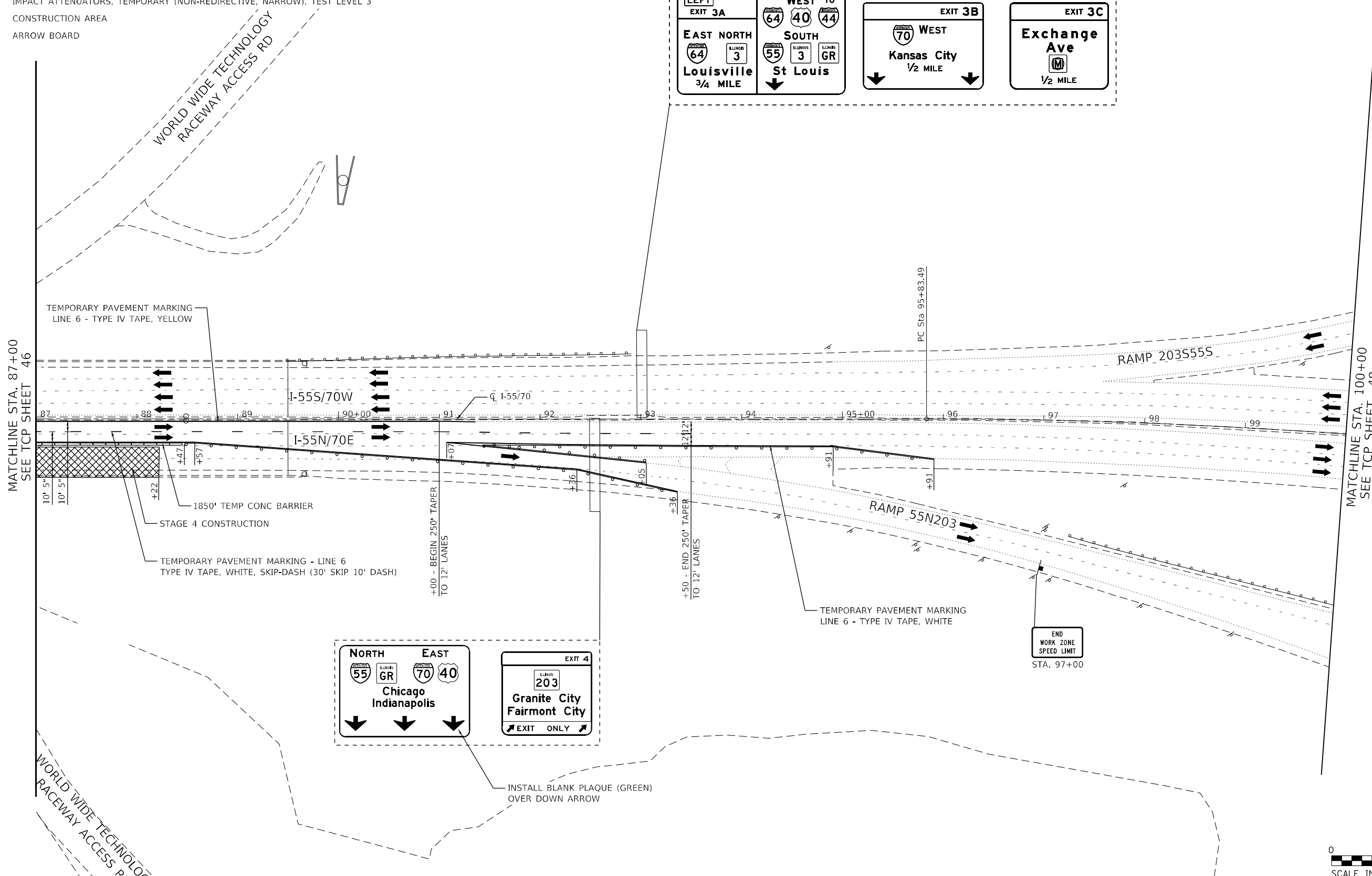
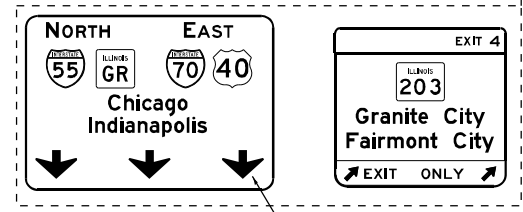
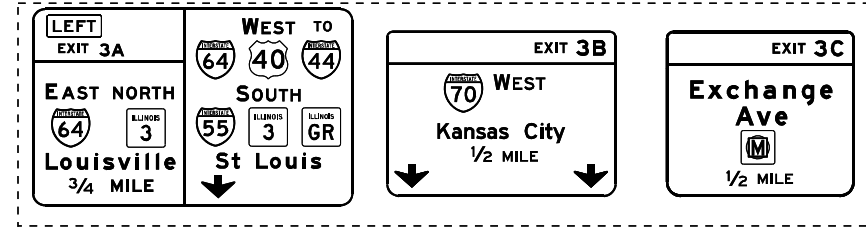

MATCHLINE STA. 87+00
SEE TCP SHEET 46

MATCHLINE STA. 100+00
SEE TCP SHEET 48

WORLD WIDE TECHNOLOGY
RACEWAY ACCESS RD

WORLD WIDE TECHNOLOGY
RACEWAY ACCESS RD

END
WORK ZONE
SPEED LIMIT
STA. 97+00

INSTALL BLANK PLAQUE (GREEN)
OVER DOWN ARROW

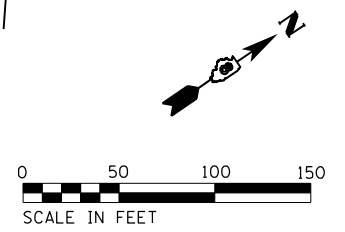

MODEL: 4646.rvt
 FILE NAME: Z:\13052229_B60_BR_Bridge\DCN\Design\Final\Fetch\Sheet\80\076K02-514-Stage 4.dwg

EFK Moen
Civil Engineering Design

USER NAME = zWaters	DESIGNED - SJF	REVISED -
PLOT SCALE = 100,0000' / in.	DRAWN - SJF	REVISED -
PLOT DATE = 8/13/2024	CHECKED - SLD	REVISED -
	DATE - 8/13/2024	REVISED -









STATE OF ILLINOIS
DEPARTMENT OF TRANSPORTATION

TRAFFIC CONTROL AND PROTECTION PLAN
STAGE 4

SCALE: 1"=50' SHEET 47 OF 5>TFC SHEETS STA. 87+00 TO STA. 100+00

F.A.I. RTE.	SECTION	COUNTY	TOTAL SHEETS	SHEET NO.
70	82-5V8-R-2	ST. CLAIR	254	81
CONTRACT NO. 76K02				
ILLINOIS FED. AID PROJECT				

LEGEND:

-  SIGN
-  DIRECTION OF TRAFFIC FLOW
-  TYPE II BARRICADES, DRUMS, OR VERTICAL BARRICADE
-  TYPE III BARRICADE
-  TEMPORARY CONCRETE BARRIER
-  IMPACT ATTENUATORS, TEMPORARY (NON-REDIRECTIVE, NARROW), TEST LEVEL 3
-  CONSTRUCTION AREA
-  ARROW BOARD

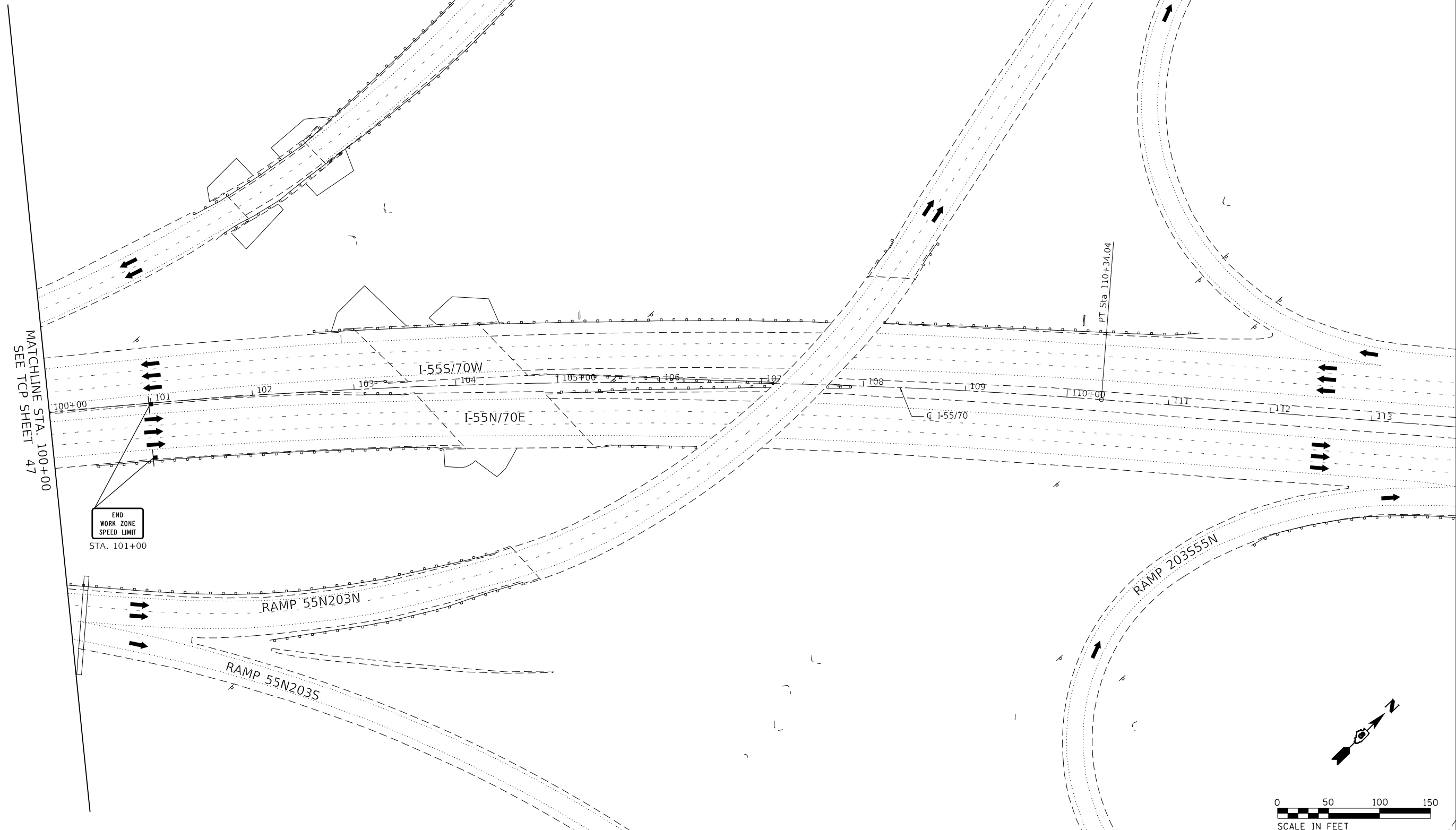

END
WORK ZONE
SPEED LIMIT
STA. 101+00

MATCHLINE STA. 100+00
SEE TOP SHEET 47

PT Sta 110+34.04

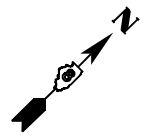
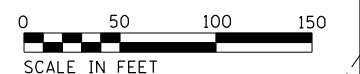

MODEL: 4646.dwg
 FILE NAME: Z:\130522\9_BGO_BR_Bridge\DCN\Design\Final\Fiber\Sheet81.DWG\K02_Sht-Stage_4.dwg

EFK Moen
Civil Engineering Design

USER NAME = zWaters	DESIGNED - SJF	REVISED -
PLOT SCALE = 100,0000' / in.	DRAWN - SJF	REVISED -
PLOT DATE = 8/13/2024	CHECKED - SLD	REVISED -
	DATE - 8/13/2024	REVISED -

**STATE OF ILLINOIS
DEPARTMENT OF TRANSPORTATION**

**TRAFFIC CONTROL AND PROTECTION PLAN
STAGE 4**

SCALE: 1"=50' SHEET 48 OF 5>TFC SHEETS STA. 100+00 TO STA. 112+00

F.A.I. RTE.	SECTION	COUNTY	TOTAL SHEETS	SHEET NO.
70	82-5V8-R-2	ST. CLAIR	254	82
CONTRACT NO. 76K02			ILLINOIS FED. AID PROJECT	

ADVANCED SIGNING ALONG I-70 (WESTBOUND)

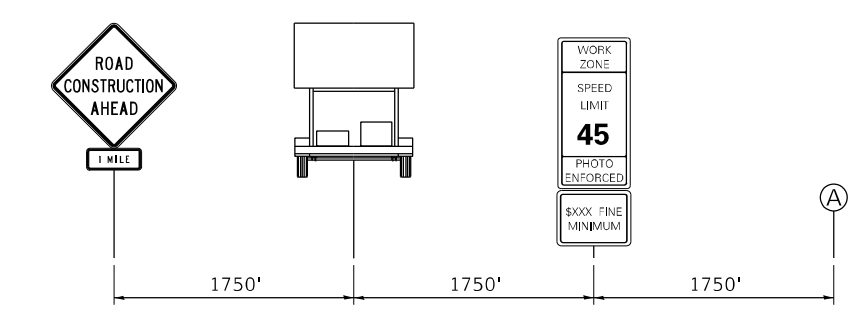

NOTE:
1. ADVANCED WARNING SIGNS SHALL BE PLACED ON EITHER SIDE OF WESTBOUND I-70.

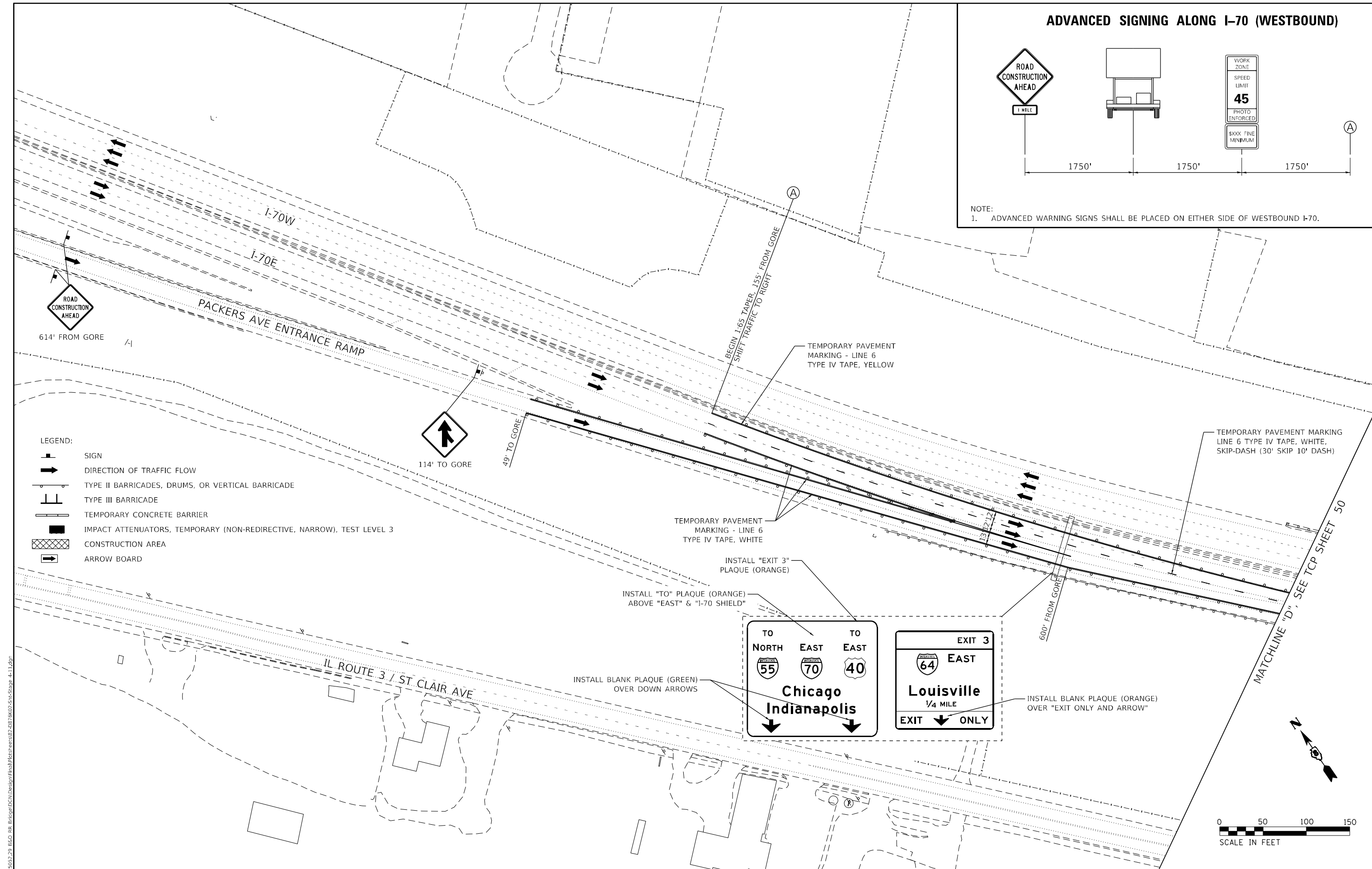

- LEGEND:**
- SIGN
 - DIRECTION OF TRAFFIC FLOW
 - TYPE II BARRICADES, DRUMS, OR VERTICAL BARRICADE
 - TYPE III BARRICADE
 - TEMPORARY CONCRETE BARRIER
 - IMPACT ATTENUATORS, TEMPORARY (NON-REDIRECTIVE, NARROW), TEST LEVEL 3
 - CONSTRUCTION AREA
 - ARROW BOARD

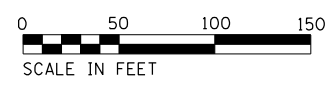
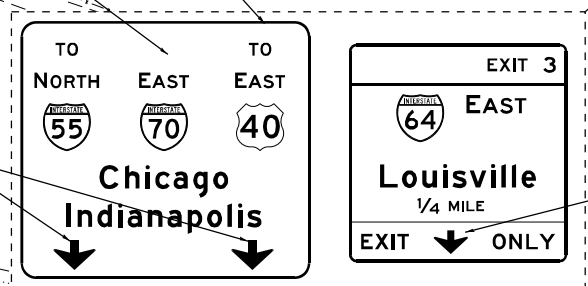

MODEL: 464611
 FILE NAME: Z:\2023\23_B60_BR_Bridge\DCN\Design\Final\Final\Sheet\82-5V8-R-2-CP-Traffic-Stage 4-1.dgn
 DATE: 8/13/2024

EFK Moen
Civil Engineering Design

USER NAME = zWaters	DESIGNED - SJF	REVISED -
PLOT SCALE = 100,0000' / in.	DRAWN - SJF	REVISED -
PLOT DATE = 8/13/2024	CHECKED - SLD	REVISED -
	DATE - 8/13/2024	REVISED -

**STATE OF ILLINOIS
DEPARTMENT OF TRANSPORTATION**

**TRAFFIC CONTROL AND PROTECTION PLAN
STAGE 4**

SCALE: 1"=50' SHEET 49 OF 5>TFC SHEETS STA. TO STA.

F.A.I. RTE.	SECTION	COUNTY	TOTAL SHEETS	SHEET NO.
70	82-5V8-R-2	ST. CLAIR	254	83
ILLINOIS FED. AID PROJECT			CONTRACT NO. 76K02	

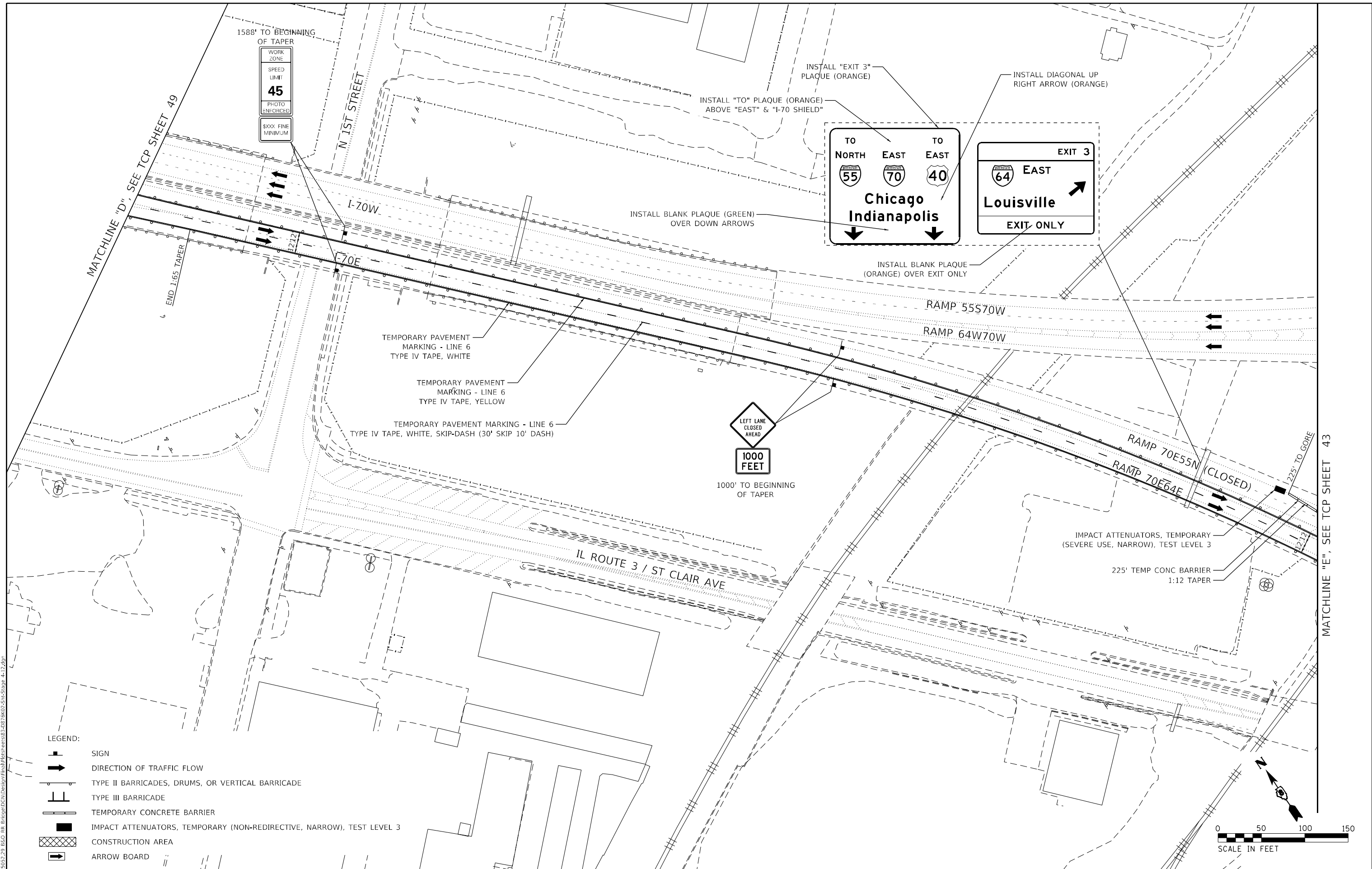

MATCHLINE "D", SEE TCP SHEET 49

1588' TO BEGINNING OF TAPER

WORK ZONE

SPEED LIMIT

45

PHOTO ENFORCED

\$300 FINE MINIMUM

N 1ST STREET

I-70W

I-70E

END 1:65 TAPER

TEMPORARY PAVEMENT MARKING - LINE 6
TYPE IV TAPE, WHITE

TEMPORARY PAVEMENT MARKING - LINE 6
TYPE IV TAPE, YELLOW

TEMPORARY PAVEMENT MARKING - LINE 6
TYPE IV TAPE, WHITE, SKIP-DASH (30' SKIP 10' DASH)

LEFT LANE CLOSED AHEAD

1000 FEET

1000' TO BEGINNING OF TAPER

IL ROUTE 3 / ST CLAIR AVE

RAMP 55S70W

RAMP 64W70W

RAMP 70E55N (CLOSED)

RAMP 70E64E

IMPACT ATTENUATORS, TEMPORARY (SEVERE USE, NARROW), TEST LEVEL 3

225' TEMP CONC BARRIER 1:12 TAPER

MATCHLINE "E", SEE TCP SHEET 43

- LEGEND:
- SIGN
 - DIRECTION OF TRAFFIC FLOW
 - TYPE II BARRICADES, DRUMS, OR VERTICAL BARRICADE
 - TYPE III BARRICADE
 - TEMPORARY CONCRETE BARRIER
 - IMPACT ATTENUATORS, TEMPORARY (NON-REDIRECTIVE, NARROW), TEST LEVEL 3
 - CONSTRUCTION AREA
 - ARROW BOARD



MODEL: 464611
 FILE NAME: Z:\13052229_B60_BR_Bridge\DCN\Design\Plan\Traffic\82-5V8-R-2-Stage 4-12.dwg
 USER: zWaters

EFK Moen
Civil Engineering Design

USER NAME = zWaters	DESIGNED - SJF	REVISED -
PLOT SCALE = 100,000' / in.	DRAWN - SJF	REVISED -
PLOT DATE = 8/13/2024	CHECKED - SLD	REVISED -
	DATE - 8/13/2024	REVISED -

STATE OF ILLINOIS
DEPARTMENT OF TRANSPORTATION

TRAFFIC CONTROL AND PROTECTION PLAN
STAGE 4

SCALE: 1"=50' SHEET 50 OF 5>TFC SHEETS STA. TO STA.

F.A.I. RTE.	SECTION	COUNTY	TOTAL SHEETS	SHEET NO.
70	82-5V8-R-2	ST. CLAIR	254	84
CONTRACT NO. 76K02			ILLINOIS FED. AID PROJECT	

MATCHLINE "F", SEE TCP SHEET 44

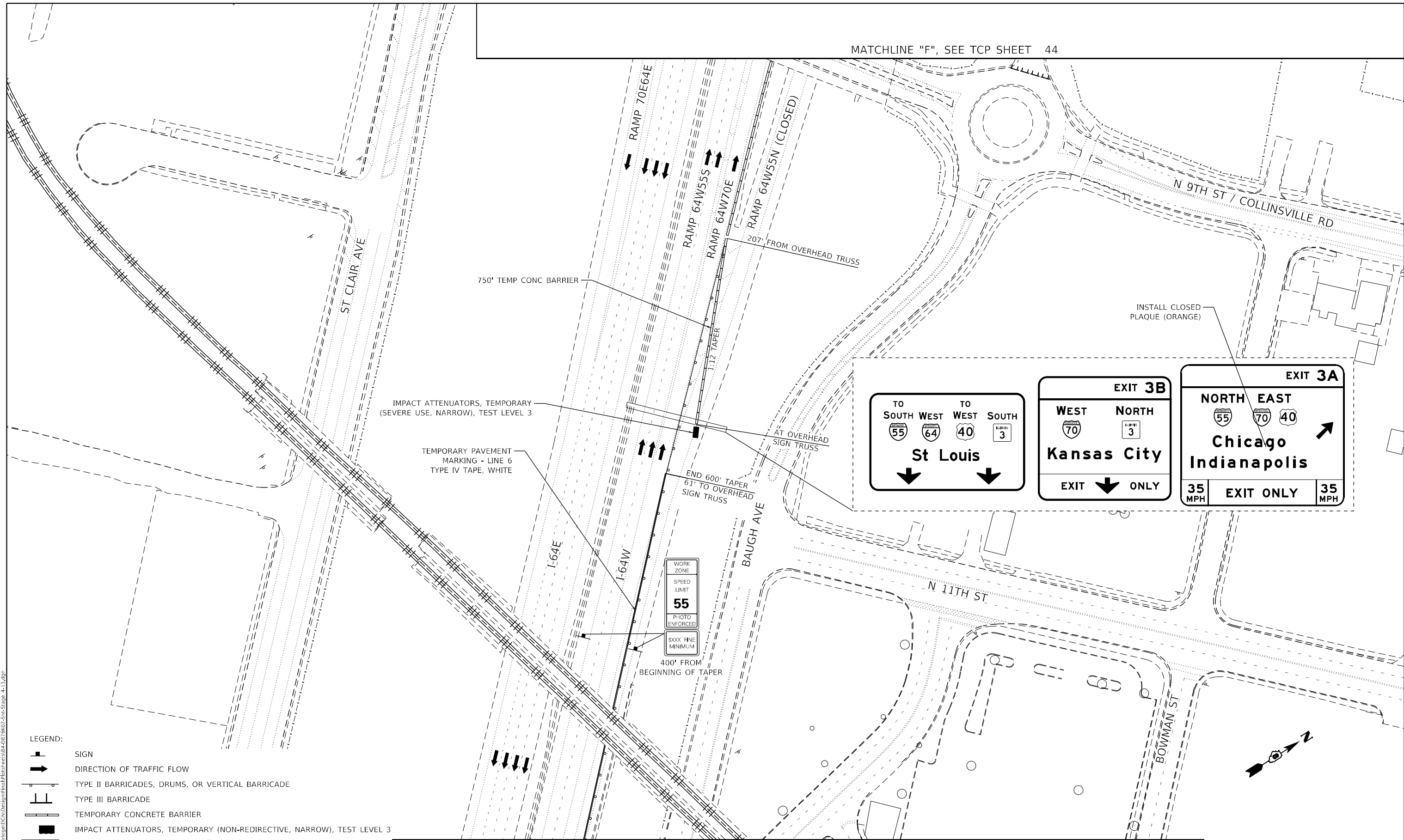

MATCHLINE "G", SEE TCP SHEET 52

- LEGEND:**
- SIGN
 - DIRECTION OF TRAFFIC FLOW
 - TYPE II BARRICADES, DRUMS, OR VERTICAL BARRICADE
 - TYPE III BARRICADE
 - TEMPORARY CONCRETE BARRIER
 - IMPACT ATTENUATORS, TEMPORARY (NON-REDIRECTIVE, NARROW), TEST LEVEL 3
 - CONSTRUCTION AREA
 - ARROW BOARD

EXIT 3A

NORTH EAST

Chicago Indianapolis

35 MPH EXIT ONLY 35 MPH

EXIT 3B

WEST NORTH

Kansas City

EXIT ONLY

TO SOUTH WEST TO WEST SOUTH

St Louis

WORK ZONE
 SPEED LIMIT
55
 PHOTO ENFORCED
 \$300 FINE MINIMUM
 400' FROM BEGINNING OF TAPER

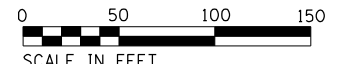
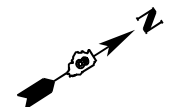

MODEL: 464611
 FILE NAME: 211305229_B60_BR_BridgeDCNDesignFinalReferences844078K02-Sub-Stage_4-13.dgn

EFK Moen
 Civil Engineering Design

USER NAME = zWaters	DESIGNED - SJF	REVISED -
PLOT SCALE = 100,0000' / in.	DRAWN - SJF	REVISED -
PLOT DATE = 8/13/2024	CHECKED - SLD	REVISED -
	DATE - 8/13/2024	REVISED -

**STATE OF ILLINOIS
 DEPARTMENT OF TRANSPORTATION**

**TRAFFIC CONTROL AND PROTECTION PLAN
 STAGE 4**

SCALE: 1"=50' SHEET 51 OF 5>TFC SHEETS STA. TO STA.

F.A.I. RTE.	SECTION	COUNTY	TOTAL SHEETS	SHEET NO.
70	82-5V8-R-2	ST. CLAIR	254	85
ILLINOIS FED. AID PROJECT			CONTRACT NO. 76K02	

LEGEND:

- SIGN
- DIRECTION OF TRAFFIC FLOW
- TYPE II BARRICADES, DRUMS, OR VERTICAL BARRICADE
- TYPE III BARRICADE
- TEMPORARY CONCRETE BARRIER
- IMPACT ATTENUATORS, TEMPORARY (NON-REDIRECTIVE, NARROW), TEST LEVEL 3
- CONSTRUCTION AREA
- ARROW BOARD

TEMPORARY PAVEMENT MARKING - LINE 6
TYPE IV TAPE, WHITE

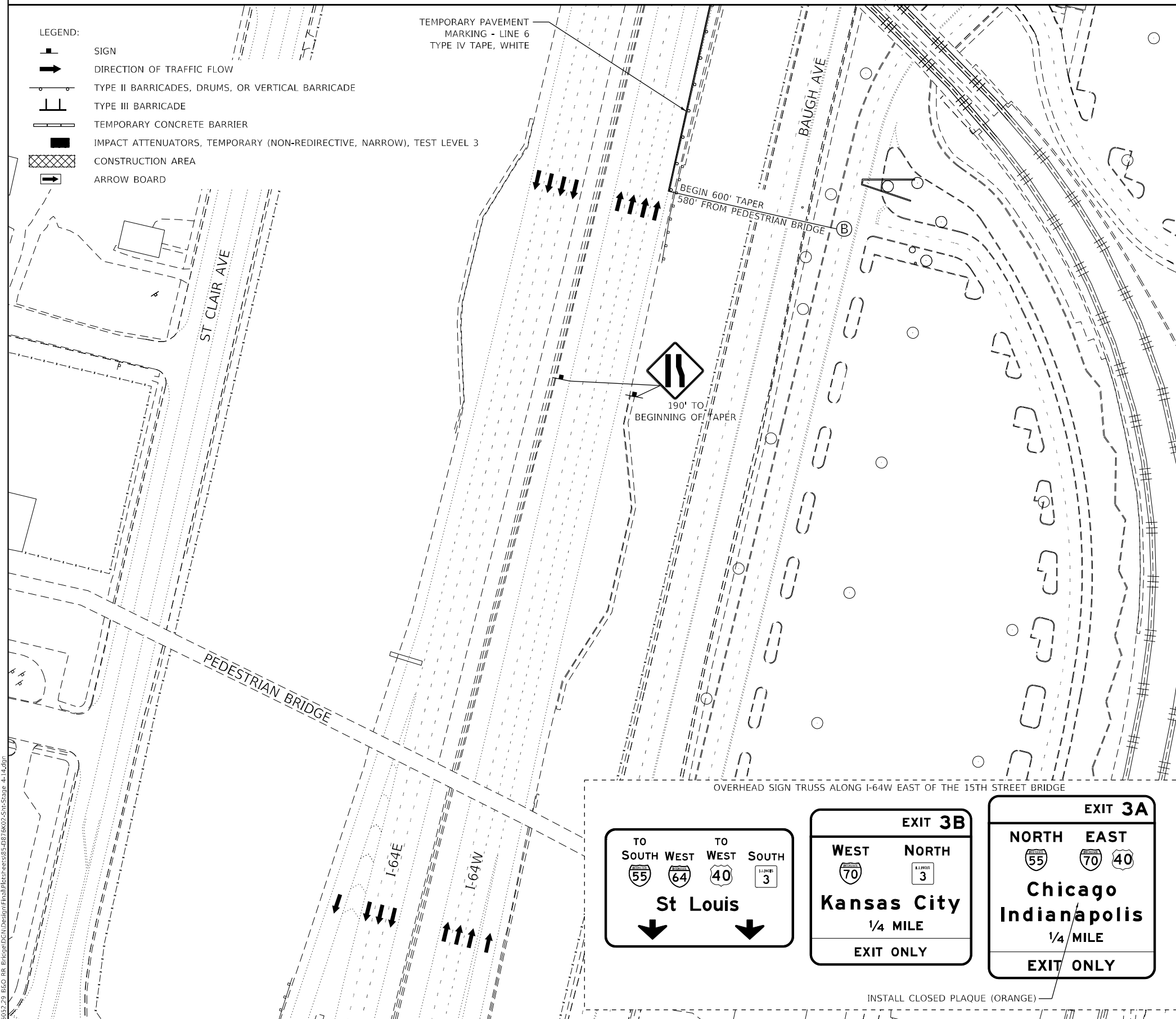

ADVANCED SIGNING ALONG I-64 (WESTBOUND)

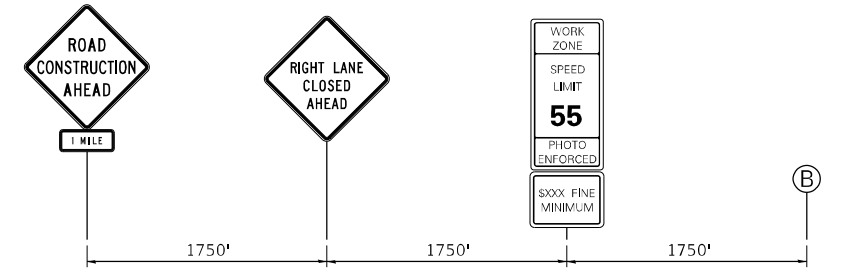

NOTE:
1. ALL ADVANCED WARNING SIGNS SHALL BE PLACED ON EITHER SIDE OF WESTBOUND I-64.

**ADVANCED SIGNING ALONG BAUGH AVE
ENTRANCE RAMP TO I-64W**

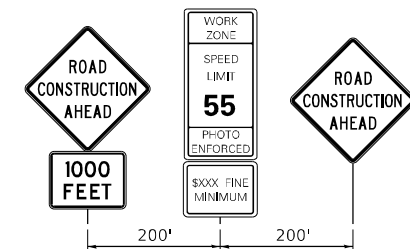

NOTE:
1. ALL ADVANCED WARNING SIGNS SHALL BE PLACED ON EITHER SIDE OF THE RAMP.

**ADVANCED SIGNING ALONG 25TH ST
ENTRANCE RAMP TO I-64W**

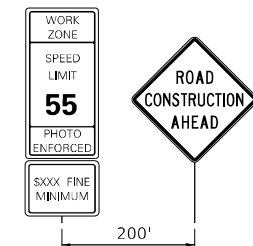

NOTE:
1. ALL ADVANCED WARNING SIGNS SHALL BE PLACED ON EITHER SIDE OF THE RAMP.

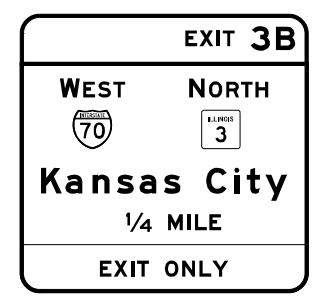
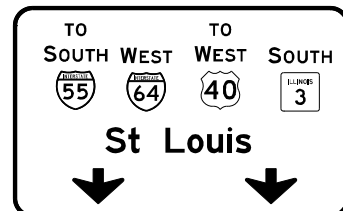

INSTALL CLOSED PLAQUE (ORANGE)



MODEL: 4/24/11
FILE NAME: 211030220_B60_BR_BridgeDesignFinal\Fiber\Sheet85-D078K02-Sht-52.dwg

EFK Moen
Civil Engineering Design

USER NAME = zWaters	DESIGNED - SJF	REVISED -
PLOT SCALE = 100,000' / in.	DRAWN - SJF	REVISED -
PLOT DATE = 8/13/2024	CHECKED - SLD	REVISED -
	DATE - 8/13/2024	REVISED -









STATE OF ILLINOIS
DEPARTMENT OF TRANSPORTATION

TRAFFIC CONTROL AND PROTECTION PLAN
STAGE 4

SCALE: 1"=50' SHEET 52 OF 5>TFC SHEETS STA. TO STA.

F.A.I. RTE.	SECTION	COUNTY	TOTAL SHEETS	SHEET NO.
70	82-5V8-R-2	ST. CLAIR	254	86
ILLINOIS FED. AID PROJECT			CONTRACT NO. 76K02	

LEGEND:

-  SIGN
-  DIRECTION OF TRAFFIC FLOW
-  TYPE II BARRICADES, DRUMS, OR VERTICAL BARRICADE
-  TYPE III BARRICADE
-  TEMPORARY CONCRETE BARRIER
-  IMPACT ATTENUATORS, TEMPORARY (NON-REDIRECTIVE, NARROW), TEST LEVEL 3
-  CONSTRUCTION AREA
-  ARROW BOARD

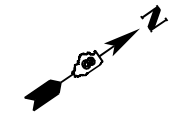
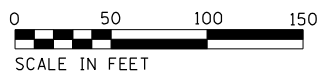
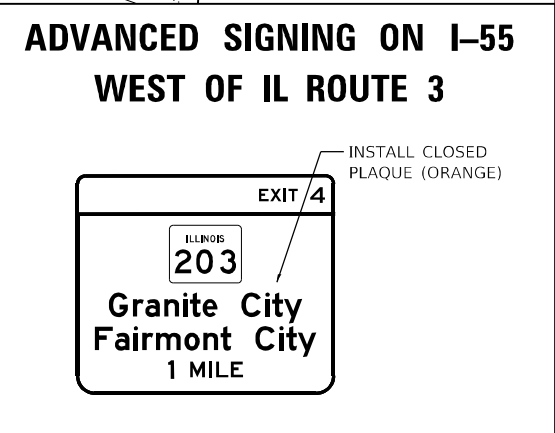
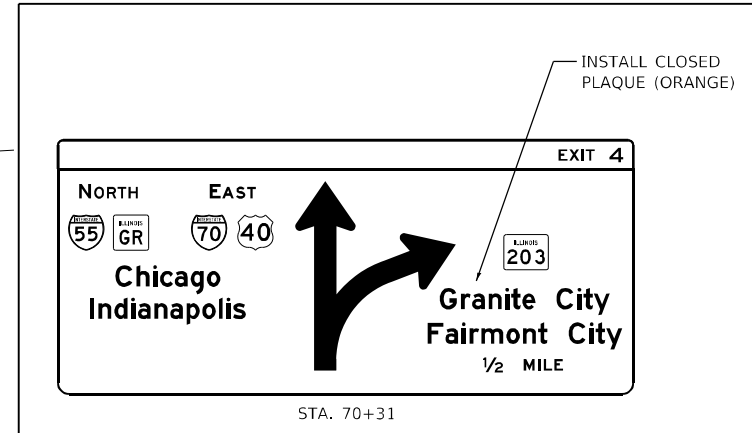
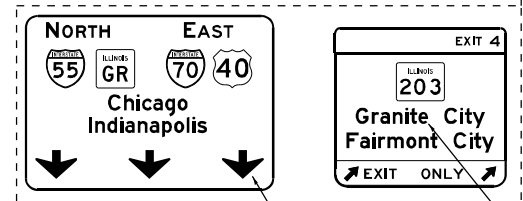
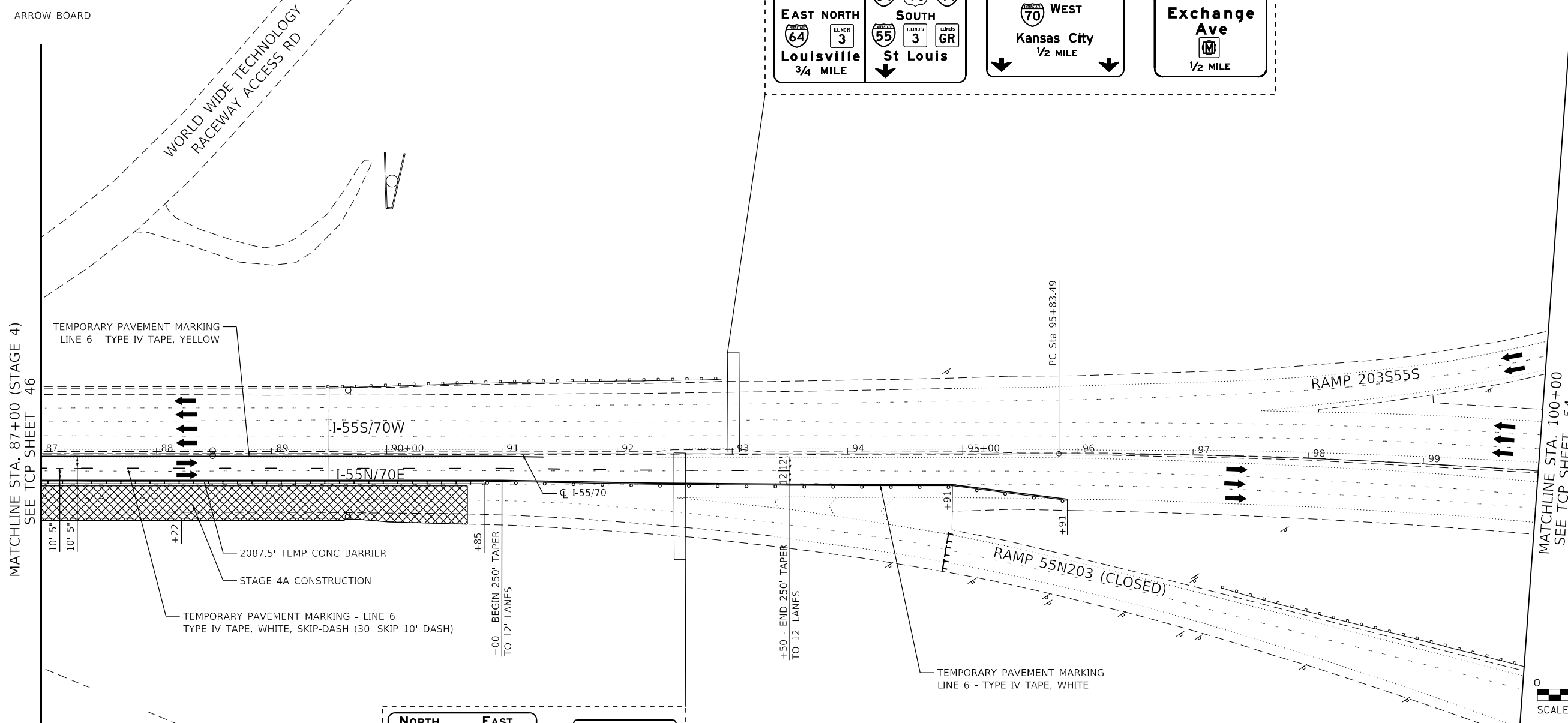
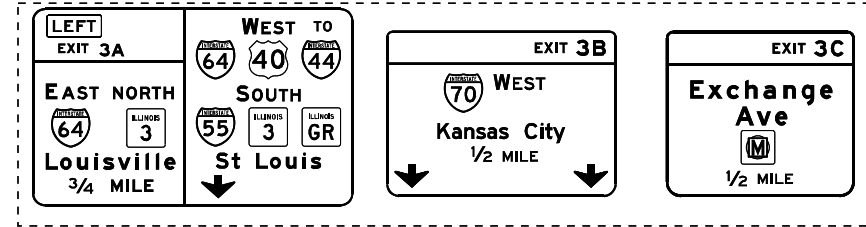

MODEL: 4464.dwg
 FILE NAME: Z:\13052229_B60_BR_Bridge\DCN\Design\Final\Final\82-5V8-R-2\Stage 4A-06.dgn

EFK Moen
Civil Engineering Design

USER NAME = zWaters	DESIGNED - SJF	REVISED -
PLOT SCALE = 100,0000' / in.	DRAWN - SJF	REVISED -
PLOT DATE = 8/13/2024	CHECKED - SLD	REVISED -
	DATE - 8/13/2024	REVISED -









**STATE OF ILLINOIS
DEPARTMENT OF TRANSPORTATION**

**TRAFFIC CONTROL AND PROTECTION PLAN
STAGE 4A**

SCALE: 1"=50' SHEET 53 OF 5>TFC SHEETS STA. 87+00 TO STA. 100+00

F.A.I. RTE.	SECTION	COUNTY	TOTAL SHEETS	SHEET NO.
70	82-5V8-R-2	ST. CLAIR	254	87
CONTRACT NO. 76K02				
ILLINOIS FED. AID PROJECT				

LEGEND:

-  SIGN
-  DIRECTION OF TRAFFIC FLOW
-  TYPE II BARRICADES, DRUMS, OR VERTICAL BARRICADE
-  TYPE III BARRICADE
-  TEMPORARY CONCRETE BARRIER
-  IMPACT ATTENUATORS, TEMPORARY (NON-REDIRECTIVE, NARROW), TEST LEVEL 3
-  CONSTRUCTION AREA
-  ARROW BOARD

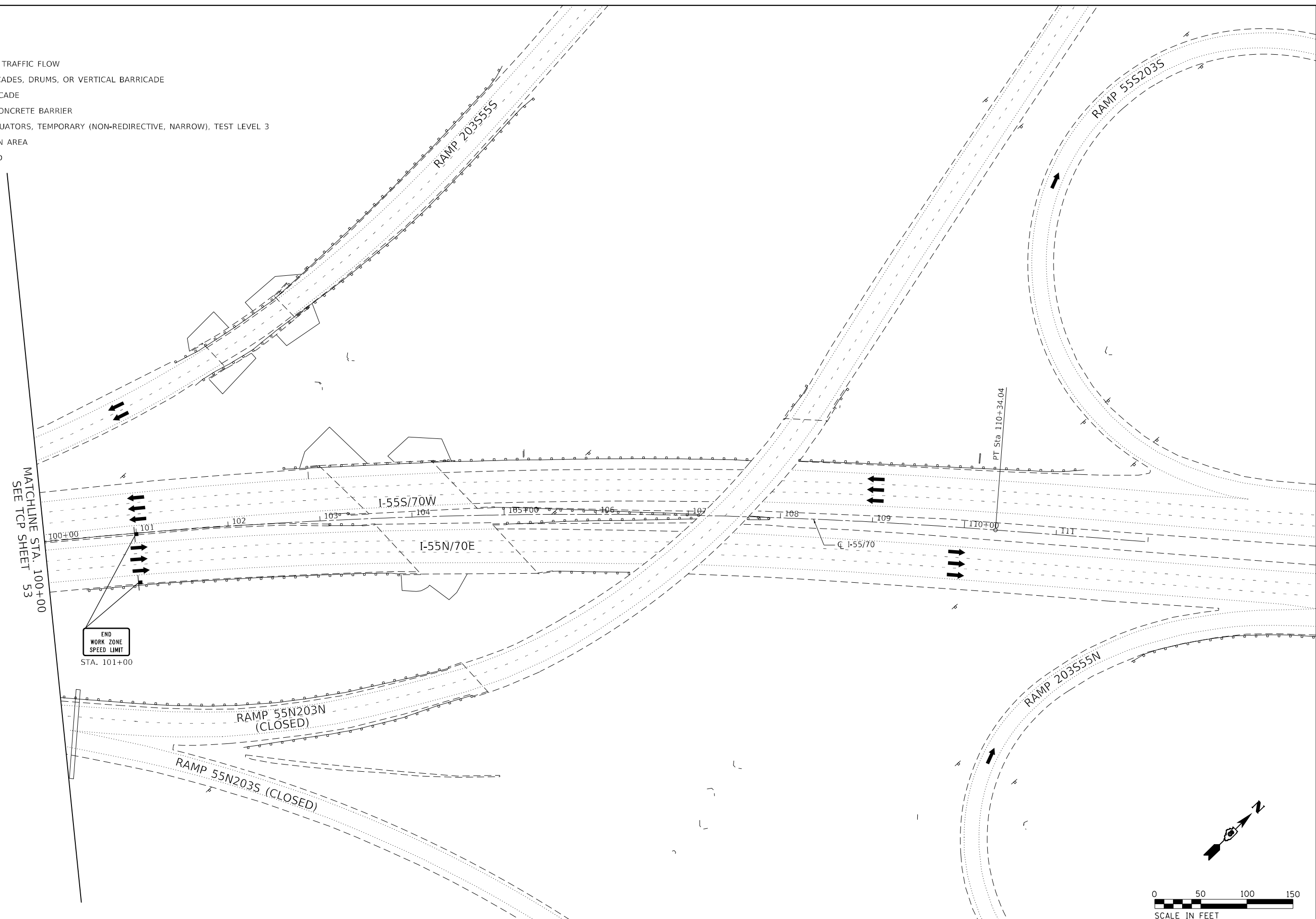

MODEL: 444444
 FILE NAME: Z:\130522\9_B&O_BR_Bridge\DCN\Design\Final\Final\Sheet\87.DWG\K02_Sht-Stage_4A-07.dwg

EFK Moen
Civil Engineering Design

USER NAME = zWaters	DESIGNED - SJF	REVISED -
PLOT SCALE = 100,0000' / in.	DRAWN - SJF	REVISED -
PLOT DATE = 8/13/2024	CHECKED - SLD	REVISED -
	DATE - 8/13/2024	REVISED -









**STATE OF ILLINOIS
DEPARTMENT OF TRANSPORTATION**

**TRAFFIC CONTROL AND PROTECTION PLAN
STAGE 4A**

SCALE: 1"=50' SHEET 54 OF 5>TFC SHEETS STA. 100+00 TO STA. 112+00

F.A.I. RTE.	SECTION	COUNTY	TOTAL SHEETS	SHEET NO.
70	82-5V8-R-2	ST. CLAIR	254	88
CONTRACT NO. 76K02			ILLINOIS FED. AID PROJECT	

LEGEND:

-  SIGN
-  DIRECTION OF TRAFFIC FLOW
-  TYPE II BARRICADES, DRUMS, OR VERTICAL BARRICADE
-  TYPE III BARRICADE
-  TEMPORARY CONCRETE BARRIER
-  IMPACT ATTENUATORS, TEMPORARY (NON-REDIRECTIVE, NARROW), TEST LEVEL 3
-  CONSTRUCTION AREA
-  ARROW BOARD

INSTALL TYPE III BARRICADES AT THE EXIT TERMINAL INTERSECTION OF THE EXCHANGE AVENUE EXIT RAMP

END WORK ZONE SPEED LIMIT
SIGN A
STA. 63+00

35 HPM
SIGN B
STA. 71+00

TEMPORARY PAVEMENT MARKING - LINE 6
TYPE IV TAPE, YELLOW

END WORK ZONE SPEED LIMIT
STA. 63+00

LEFT EXIT 3A EAST NORTH 64 1/4 MILE Louisville	WEST TO 64 40 44 3 3 GR St Louis	EXIT 3B 70 WEST Kansas City	EXIT 3C Exchange Ave M
---	---	-----------------------------------	------------------------------

INSTALL CLOSED PLAQUE (ORANGE)

INSTALL BLANK PLAQUE (GREEN) OVER DOWN ARROW

TEMPORARY PAVEMENT MARKING
LINE 6 - TYPE IV TAPE, WHITE

TEMPORARY PAVEMENT MARKING - LINE 6
TYPE IV TAPE, WHITE, SKIP-DASH (30' SKIP 10' DASH)

TEMPORARY PAVEMENT MARKING - LINE 6
TYPE IV TAPE, WHITE, SKIP-DASH (9' SKIP 3' DASH)

STAGE 6 CONSTRUCTION
2200' TEMP CONC BARRIER
SIGN B

NORTH 55 GR Chicago Indianapolis	EAST 70 40 203 Granite City Fairmont City 1/2 MILE
---	---

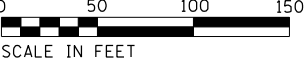

MATCHLINE STA. 73+00
SEE TCP SHEET 56

MODEL: 464611
FILE NAME: Z:\13052-29_BCO_BR_Bldg\DC\Design\Plan\Refer\825-D878K02-Sht-Stage 6-04.dwg

EFK Moen
Civil Engineering Design









USER NAME = zWaters	DESIGNED - SJF	REVISED -	
	DRAWN - SJF	REVISED -	
PLOT SCALE = 100,0000' / in.	CHECKED - SLD	REVISED -	
PLOT DATE = 8/13/2024	DATE - 8/13/2024	REVISED -	

**STATE OF ILLINOIS
DEPARTMENT OF TRANSPORTATION**

**TRAFFIC CONTROL AND PROTECTION PLAN
STAGE 6**

SCALE: 1"=50' SHEET 55 OF 5>TFC SHEETS STA. TO STA. 73+00

F.A.I. RTE.	SECTION	COUNTY	TOTAL SHEETS	SHEET NO.
70	82-5V8-R-2	ST. CLAIR	254	89
CONTRACT NO. 76K02				
ILLINOIS FED. AID PROJECT				

- LEGEND:
-  SIGN
 -  DIRECTION OF TRAFFIC FLOW
 -  TYPE II BARRICADES, DRUMS, OR VERTICAL BARRICADE
 -  TYPE III BARRICADE
 -  TEMPORARY CONCRETE BARRIER
 -  IMPACT ATTENUATORS, TEMPORARY (NON-REDIRECTIVE, NARROW), TEST LEVEL 3
 -  CONSTRUCTION AREA
 -  ARROW BOARD

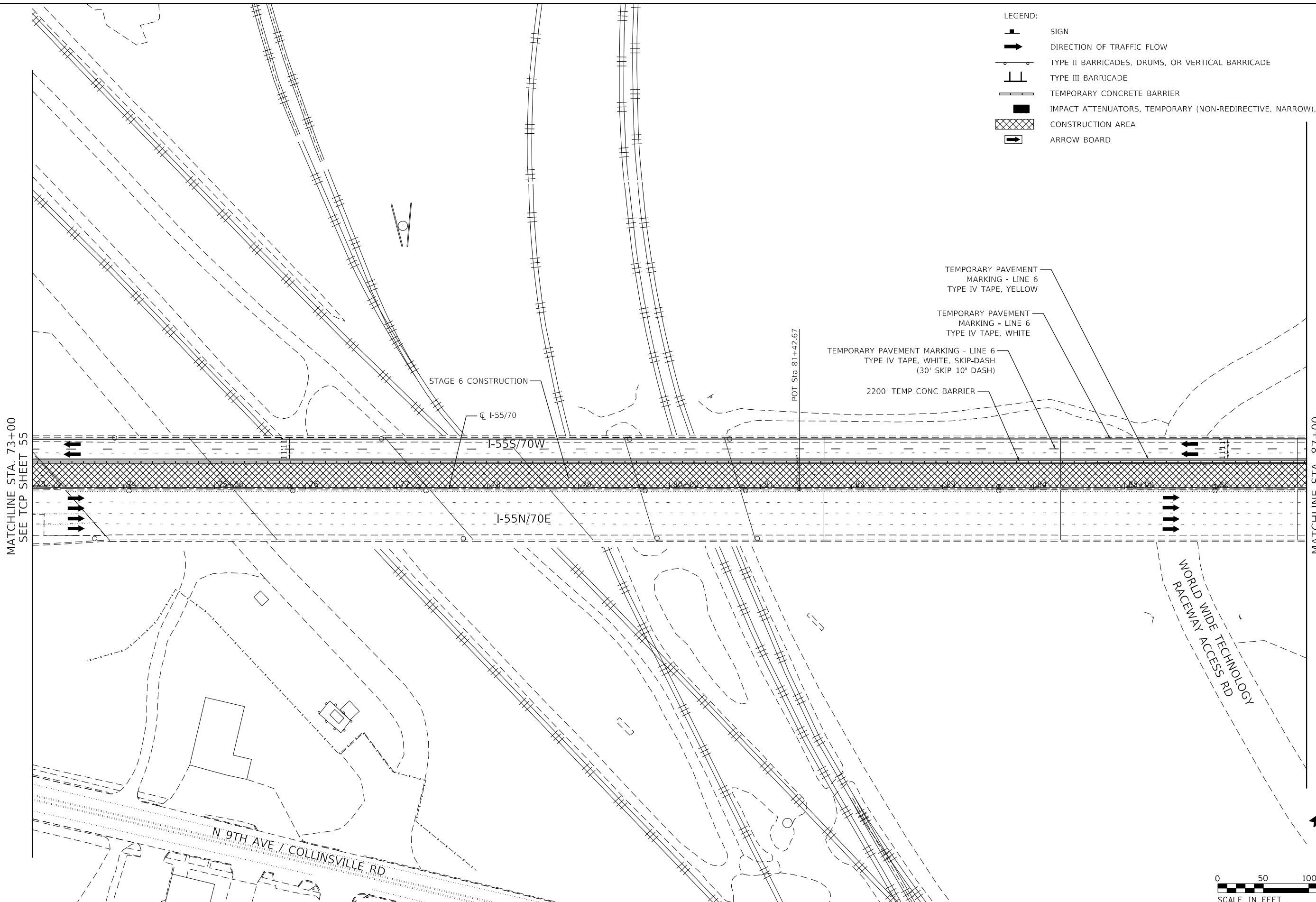

MATCHLINE STA. 73+00
SEE TCP SHEET 55

MATCHLINE STA. 87+00
SEE TCP SHEET 57

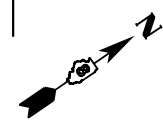
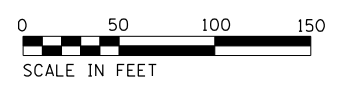

MODEL: 464611
 FILE NAME: Z:\1305229_B60_BR_Bridge\DC\Design\Final\Revised\82-5V8-R-2-CP-56-Stage 6-01.dwg

EFK Moen
Civil Engineering Design

USER NAME = zWaters	DESIGNED - SJF	REVISED -
PLOT SCALE = 100,0000' / in.	DRAWN - SJF	REVISED -
PLOT DATE = 8/13/2024	CHECKED - SLD	REVISED -
	DATE - 8/13/2024	REVISED -









**STATE OF ILLINOIS
DEPARTMENT OF TRANSPORTATION**

**TRAFFIC CONTROL AND PROTECTION PLAN
STAGE 6**

SCALE: 1"=50' SHEET 56 OF 5>TFC SHEETS STA. 73+00 TO STA. 87+00

F.A.I. RTE.	SECTION	COUNTY	TOTAL SHEETS	SHEET NO.
70	82-5V8-R-2	ST. CLAIR	254	90
CONTRACT NO. 76K02				
ILLINOIS FED. AID PROJECT				

LEGEND:

-  SIGN
-  DIRECTION OF TRAFFIC FLOW
-  TYPE II BARRICADES, DRUMS, OR VERTICAL BARRICADE
-  TYPE III BARRICADE
-  TEMPORARY CONCRETE BARRIER
-  IMPACT ATTENUATORS, TEMPORARY (NON-REDIRECTIVE, NARROW), TEST LEVEL 3
-  CONSTRUCTION AREA
-  ARROW BOARD

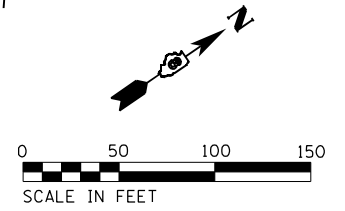
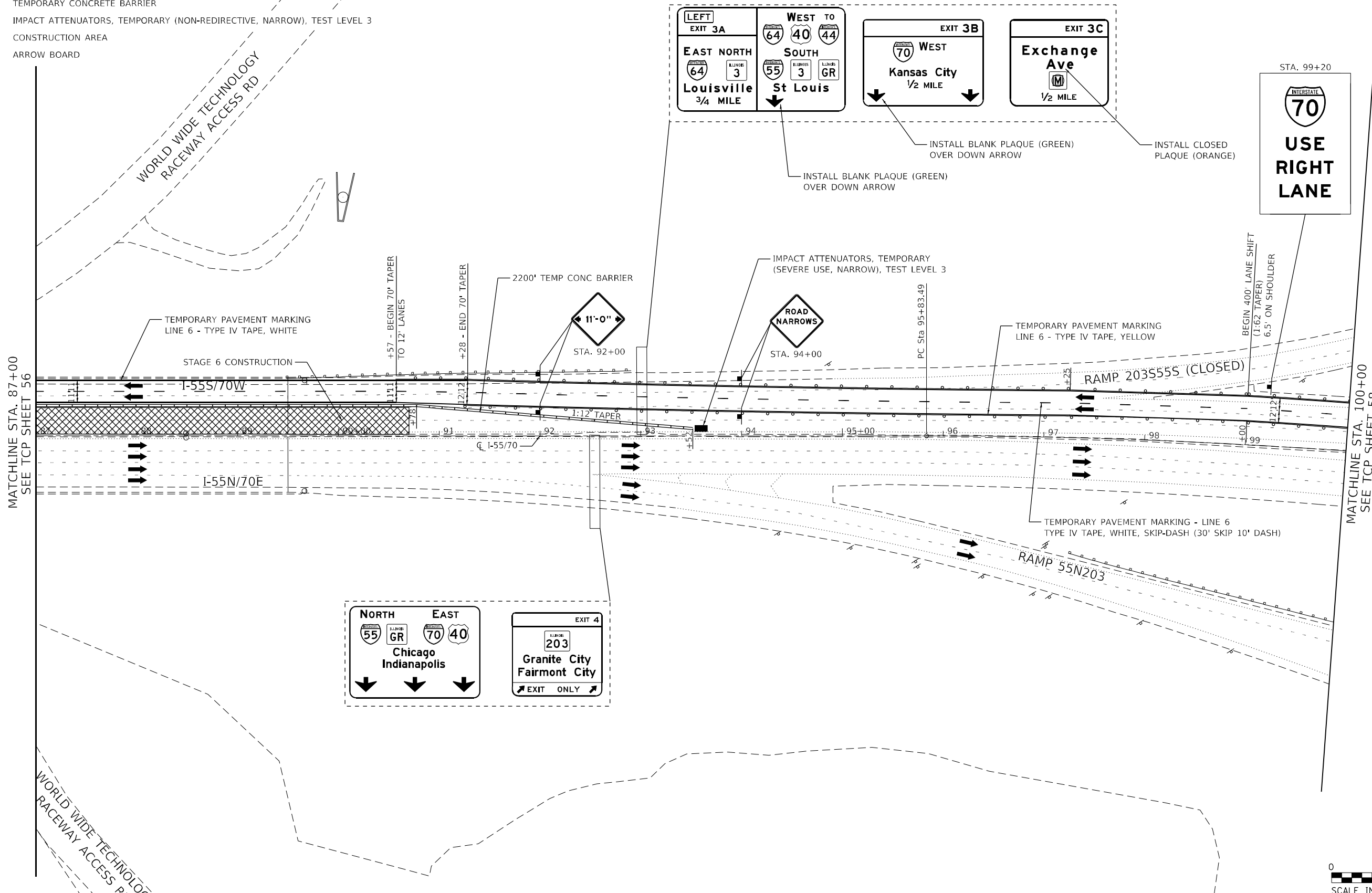

MODEL: 464641
 FILE NAME: Z:\13052229_B60_BR_Bridge\DCN\Design\Final\Fetch\Sheet\90A076K02-Sub-Stage-6-06.dgn

EFK Moen
Civil Engineering Design

USER NAME = zWaters	DESIGNED - SJF	REVISED -
DRAWN - SJF	REVISED -	
PLOT SCALE = 100,0000' / in.	CHECKED - SLD	REVISED -
PLOT DATE = 8/13/2024	DATE - 8/13/2024	REVISED -









**STATE OF ILLINOIS
DEPARTMENT OF TRANSPORTATION**

**TRAFFIC CONTROL AND PROTECTION PLAN
STAGE 6**

SCALE: 1"=50' SHEET 57 OF 5>TFC SHEETS STA. 87+00 TO STA. 100+00

F.A.I. RTE.	SECTION	COUNTY	TOTAL SHEETS	SHEET NO.
70	82-5V8-R-2	ST. CLAIR	254	91
CONTRACT NO. 76K02				
ILLINOIS FED. AID PROJECT				

LEGEND:

-  SIGN
-  DIRECTION OF TRAFFIC FLOW
-  TYPE II BARRICADES, DRUMS, OR VERTICAL BARRICADE
-  TYPE III BARRICADE
-  TEMPORARY CONCRETE BARRIER
-  IMPACT ATTENUATORS, TEMPORARY (NON-REDIRECTIVE, NARROW), TEST LEVEL 3
-  CONSTRUCTION AREA
-  ARROW BOARD

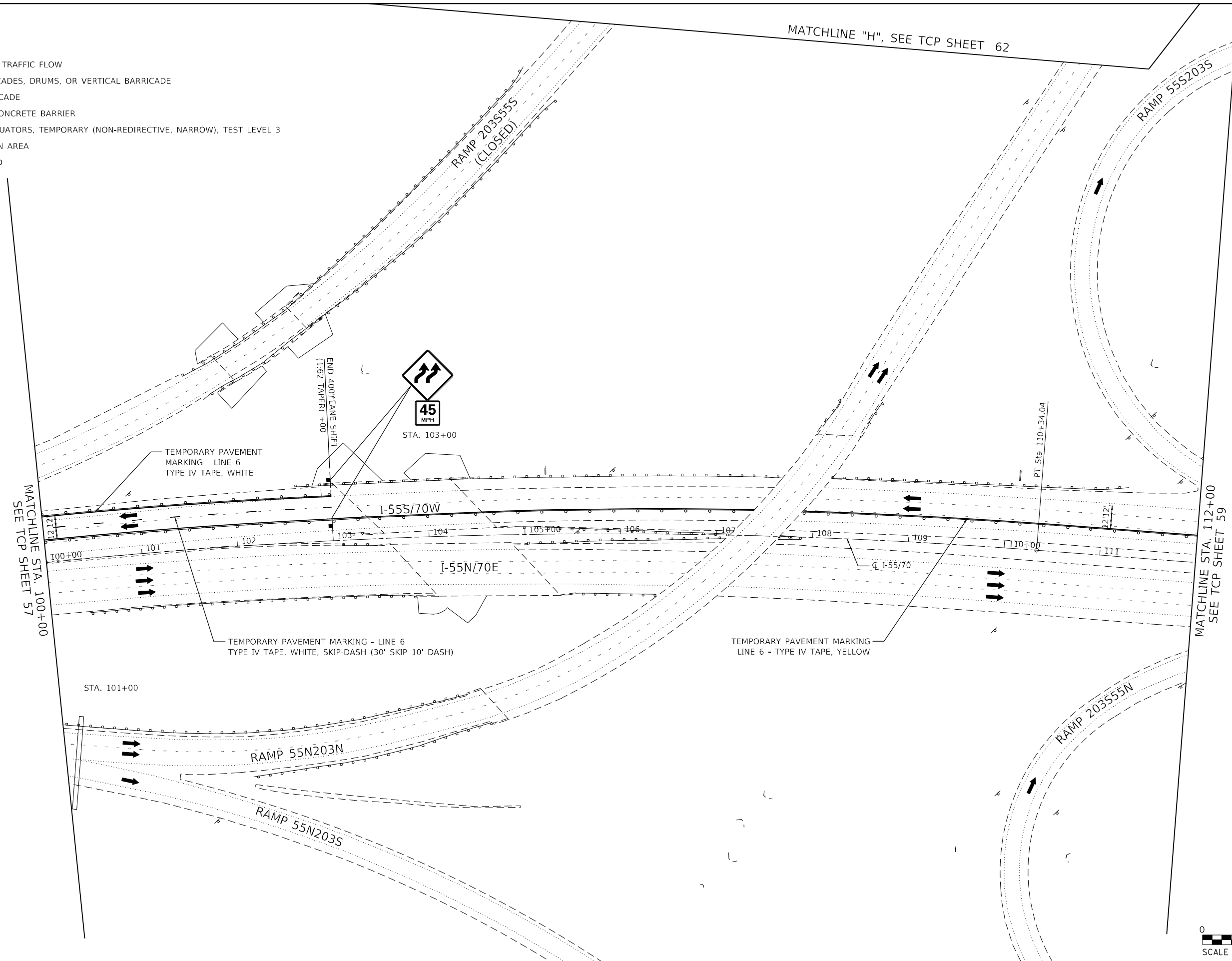

MODEL: 464641
 FILE NAME: Z:\13052229_B60_BR_Bridge\DCN\Design\Final\Fiber\Sheet914078K02-Sht-Stage 6-02.dgn

EFK Moen
Civil Engineering Design

USER NAME = zWaters	DESIGNED - SJF	REVISED -
PLOT SCALE = 100,0000' / in.	DRAWN - SJF	REVISED -
PLOT DATE = 8/13/2024	CHECKED - SLD	REVISED -
	DATE - 8/13/2024	REVISED -

**STATE OF ILLINOIS
DEPARTMENT OF TRANSPORTATION**

**TRAFFIC CONTROL AND PROTECTION PLAN
STAGE 6**

SCALE: 1"=50' SHEET 58 OF 5>TFC SHEETS STA. 100+00 TO STA. 112+00

F.A.I. RTE.	SECTION	COUNTY	TOTAL SHEETS	SHEET NO.
70	82-5V8-R-2	ST. CLAIR	254	92
CONTRACT NO. 76K02				
ILLINOIS FED. AID PROJECT				

- LEGEND:**
- SIGN
 - DIRECTION OF TRAFFIC FLOW
 - TYPE II BARRICADES, DRUMS, OR VERTICAL BARRICADE
 - TYPE III BARRICADE
 - TEMPORARY CONCRETE BARRIER
 - IMPACT ATTENUATORS, TEMPORARY (NON-REDIRECTIVE, NARROW), TEST LEVEL 3
 - CONSTRUCTION AREA
 - ARROW BOARD

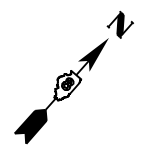
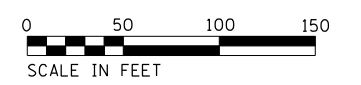
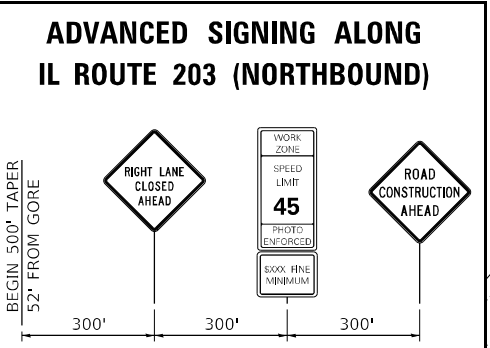
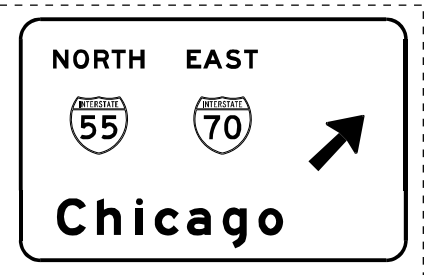
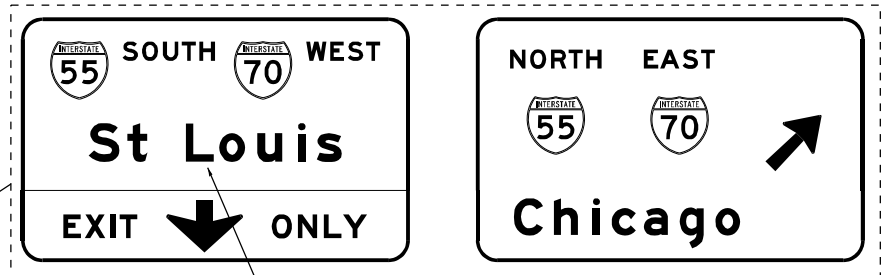
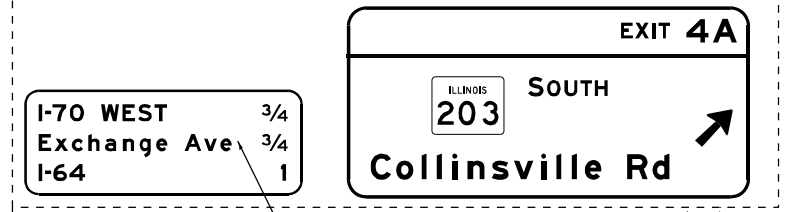

MODEL: 464641
 FILE NAME: Z:\13052239_B60_BR_Bridge\DCN\Design\Final\Revised\82-5V8-R-2-0876K02-5-Stage 6-08.dgn

EFK Moen
Civil Engineering Design

USER NAME = zWaters
 DESIGNED - SJF
 DRAWN - SJF
 CHECKED - SLD
 DATE - 8/13/2024
 PLOT SCALE = 1/8" = 100,000' / in.
 PLOT DATE = 8/13/2024

REVISED -
 REVISED -
 REVISED -
 REVISED -

STATE OF ILLINOIS
DEPARTMENT OF TRANSPORTATION









TRAFFIC CONTROL AND PROTECTION PLAN
STAGE 6
 SCALE: 1"=50'
 SHEET 59 OF 5>TFC SHEETS
 STA. 112+00 TO STA. 126+00

F.A.I. RTE.	SECTION	COUNTY	TOTAL SHEETS	SHEET NO.
70	82-5V8-R-2	ST. CLAIR	254	93
CONTRACT NO. 76K02				
ILLINOIS FED. AID PROJECT				

MATCHLINE STA. 112+00
SEE TCP SHEET 58

MATCHLINE STA. 126+00
SEE TCP SHEET 60

LEGEND:

-  SIGN
-  DIRECTION OF TRAFFIC FLOW
-  TYPE II BARRICADES, DRUMS, OR VERTICAL BARRICADE
-  TYPE III BARRICADE
-  TEMPORARY CONCRETE BARRIER
-  IMPACT ATTENUATORS, TEMPORARY (NON-REDIRECTIVE, NARROW), TEST LEVEL 3
-  CONSTRUCTION AREA
-  ARROW BOARD

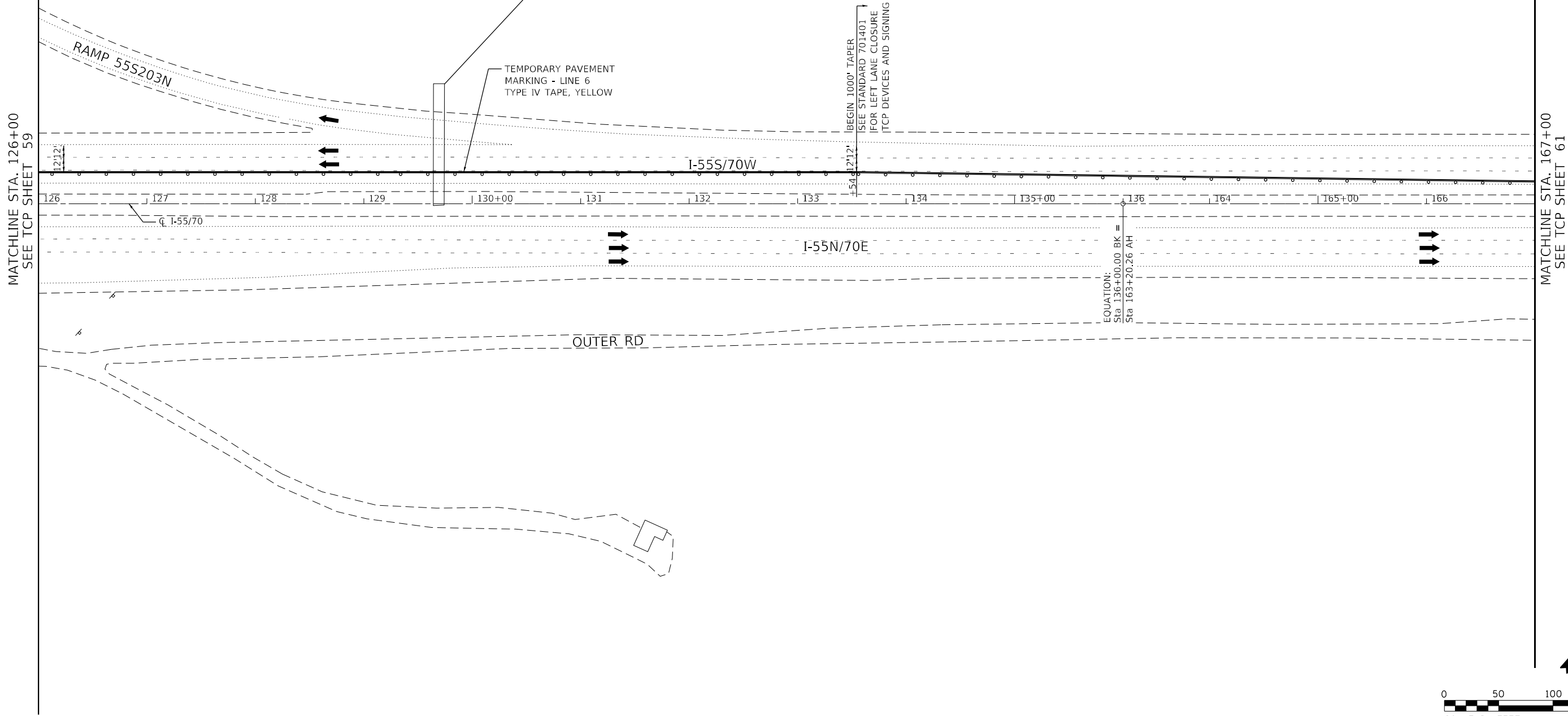
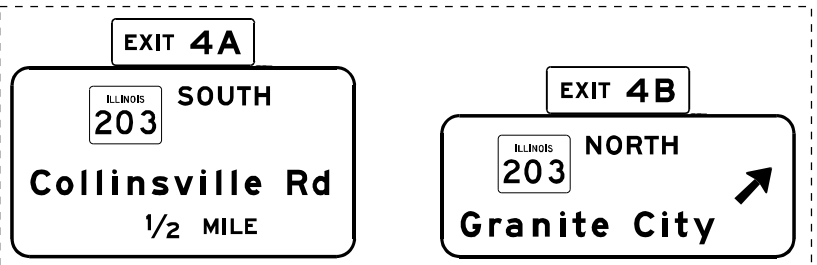

MATCHLINE STA. 126+00
SEE TCP SHEET 59

MATCHLINE STA. 167+00
SEE TCP SHEET 61

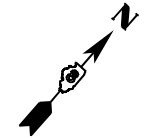
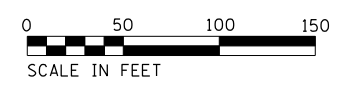

MODEL: 4646.dwg
 FILE NAME: Z:\1305229 B&O BR Bridge\DCN\Design\Final\Fetch\Sheet93-D878K02-Sht-Stage 6-09.dwg

EFK Moen
Civil Engineering Design

USER NAME = zWaters	DESIGNED - SJF	REVISED -
DRAWN - SJF	REVISOR -	
PLOT SCALE = 100,0000' / in.	CHECKED - SLD	REVISED -
PLOT DATE = 8/13/2024	DATE - 8/13/2024	REVISED -









**STATE OF ILLINOIS
DEPARTMENT OF TRANSPORTATION**

**TRAFFIC CONTROL AND PROTECTION PLAN
STAGE 6**

SCALE: 1"=50' SHEET 60 OF 5>TFC SHEETS STA. 126+00 TO STA. 167+00

F.A.I. RTE.	SECTION	COUNTY	TOTAL SHEETS	SHEET NO.
70	82-5V8-R-2	ST. CLAIR	254	94
CONTRACT NO. 76K02			ILLINOIS FED. AID PROJECT	

LEGEND:

-  SIGN
-  DIRECTION OF TRAFFIC FLOW
-  TYPE II BARRICADES, DRUMS, OR VERTICAL BARRICADE
-  TYPE III BARRICADE
-  TEMPORARY CONCRETE BARRIER
-  IMPACT ATTENUATORS, TEMPORARY (NON-REDIRECTIVE, NARROW), TEST LEVEL 3
-  CONSTRUCTION AREA
-  ARROW BOARD

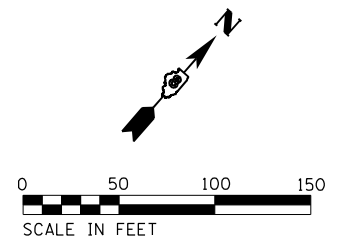
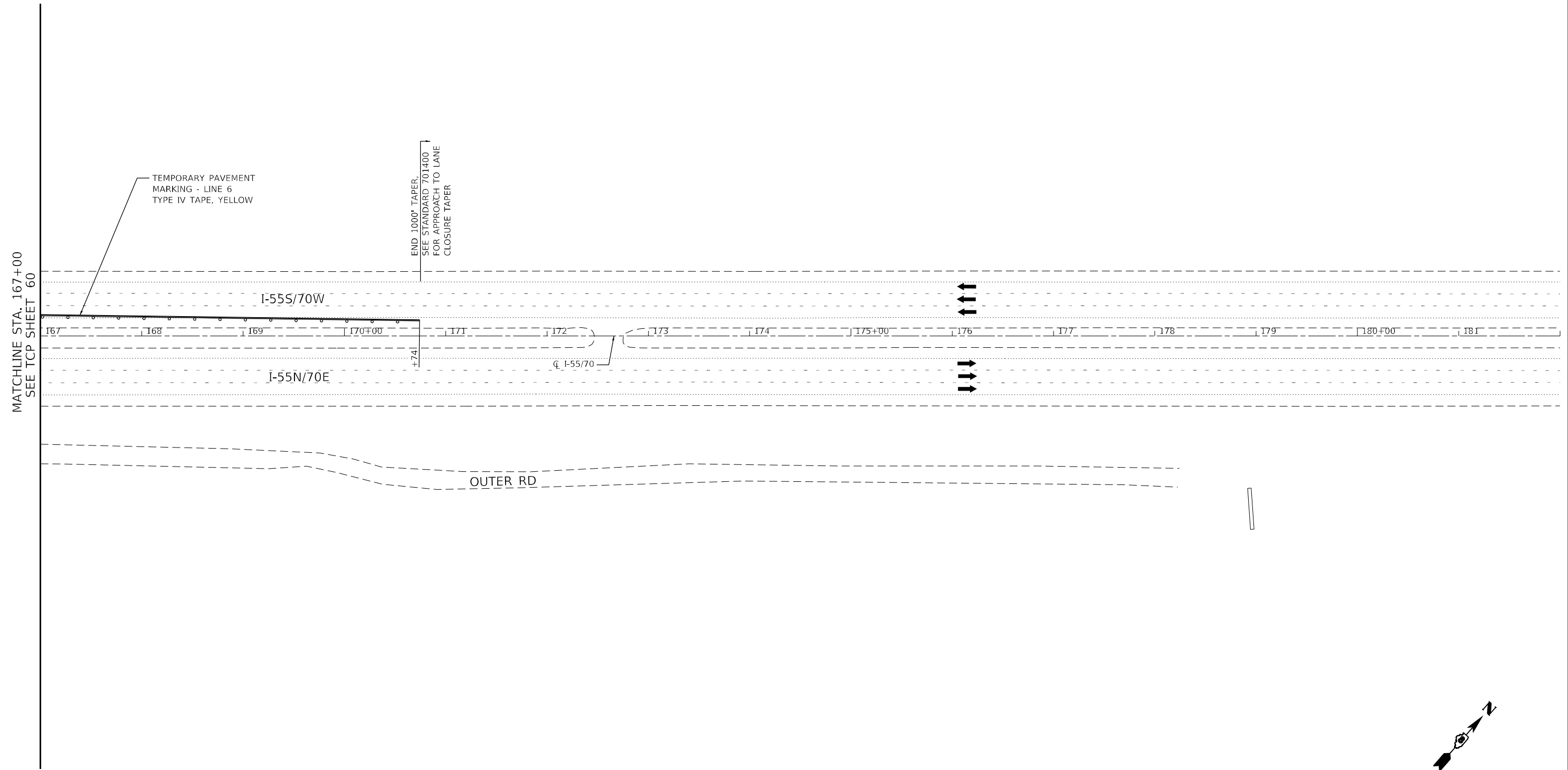

MODEL: 464611
 FILE NAME: Z:\1305229 B&O BR Bridge\DCN\Design\Final\Figures\94-0876K02-Sht-Stage 6-10.dgn

EFK Moen
Civil Engineering Design

USER NAME = zWaters	DESIGNED - SJF	REVISED -
PLOT SCALE = 100,0000' / in.	DRAWN - SJF	REVISED -
PLOT DATE = 8/13/2024	CHECKED - SLD	REVISED -
	DATE - 8/13/2024	REVISED -









**STATE OF ILLINOIS
DEPARTMENT OF TRANSPORTATION**

**TRAFFIC CONTROL AND PROTECTION PLAN
STAGE 6**

SCALE: 1"=50' SHEET 61 OF 5>TFC SHEETS STA. 167+00 TO STA. 182+00

F.A.I. RTE.	SECTION	COUNTY	TOTAL SHEETS	SHEET NO.
70	82-5V8-R-2	ST. CLAIR	254	95
ILLINOIS FED. AID PROJECT			CONTRACT NO. 76K02	

LEGEND:

-  SIGN
-  DIRECTION OF TRAFFIC FLOW
-  TYPE II BARRICADES, DRUMS, OR VERTICAL BARRICADE
-  TYPE III BARRICADE
-  TEMPORARY CONCRETE BARRIER
-  IMPACT ATTENUATORS, TEMPORARY (NON-REDIRECTIVE, NARROW), TEST LEVEL 3
-  CONSTRUCTION AREA
-  ARROW BOARD

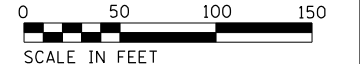
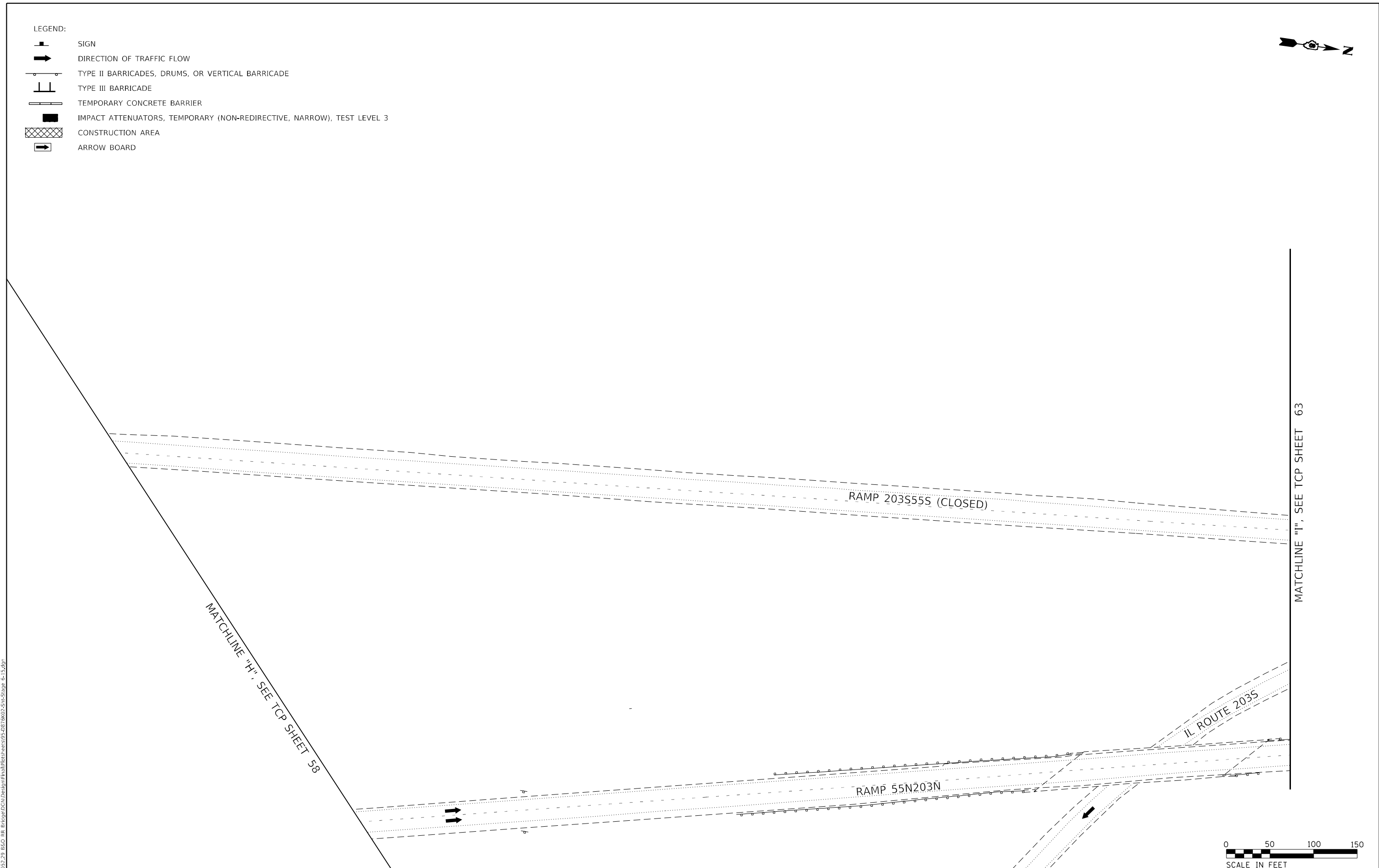

MODEL: d:\464\h
 FILE NAME: Z:\130522\9_B&O_BR_Bridge\DCN\Design\Final\Fetch\Sheet\95-0876K02-Sht-Stage 6-15.dgn

EFK Moen
Civil Engineering Design

USER NAME = zWaters	DESIGNED - SJF	REVISED -
DRAWN - SJF	REVISOR -	
PLOT SCALE = 100,0000' / in.	CHECKED - SLD	REVISED -
PLOT DATE = 8/13/2024	DATE - 8/13/2024	REVISED -









DESIGNED - SJF	REVISED -
DRAWN - SJF	REVISOR -
CHECKED - SLD	REVISED -
DATE - 8/13/2024	REVISED -

**STATE OF ILLINOIS
DEPARTMENT OF TRANSPORTATION**

**TRAFFIC CONTROL AND PROTECTION PLAN
STAGE 6**

SCALE: 1"=50' SHEET 62 OF 5>TFC SHEETS STA. TO STA.

F.A.I. RTE.	SECTION	COUNTY	TOTAL SHEETS	SHEET NO.
70	82-5V8-R-2	ST. CLAIR	254	96
CONTRACT NO. 76K02				
ILLINOIS FED. AID PROJECT				

- LEGEND:
-  SIGN
 -  DIRECTION OF TRAFFIC FLOW
 -  TYPE II BARRICADES, DRUMS, OR VERTICAL BARRICADE
 -  TYPE III BARRICADE
 -  TEMPORARY CONCRETE BARRIER
 -  IMPACT ATTENUATORS, TEMPORARY (NON-REDIRECTIVE, NARROW), TEST LEVEL 3
 -  CONSTRUCTION AREA
 -  ARROW BOARD

ADVANCED SIGNING ALONG IL ROUTE 203 (SOUTHBOUND)

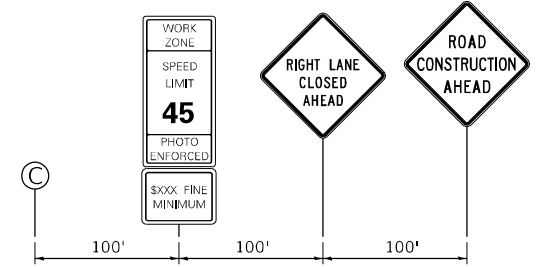

NOTE:
1. ADVANCED WARNING SIGNS SHALL BE PLACED ON EITHER SIDE OF SOUTHBOUND IL ROUTE 203.

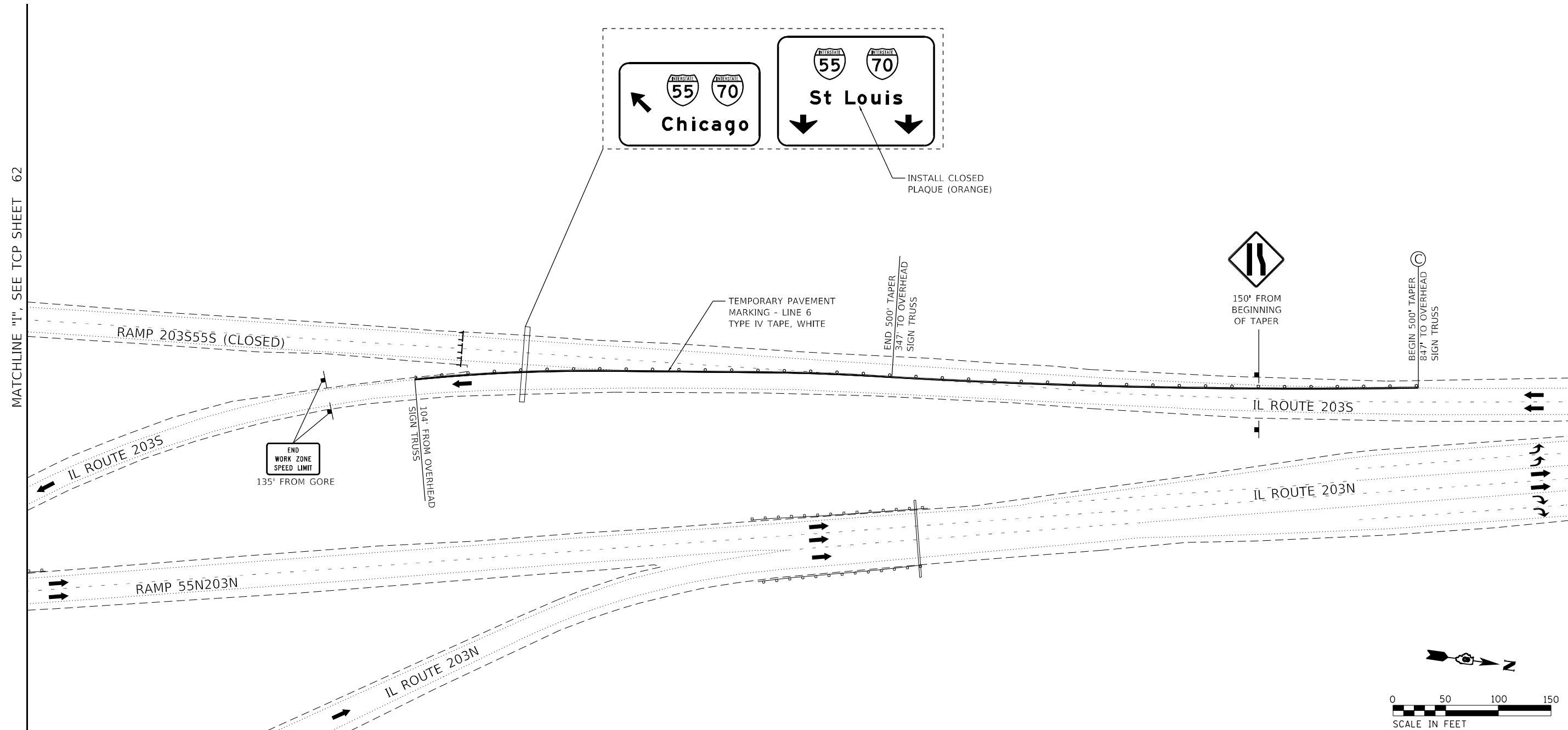

MODEL: 4646.dwg
 FILE NAME: Z:\1305229 B&O BR Bridge\DCN\Design\Final\Sheet\95-0876K02-Sht-Stage 6-16.dgn

EFK Moen
Civil Engineering Design

USER NAME = zWaters	DESIGNED - SJF	REVISED -
PLOT SCALE = 100,000' / in.	DRAWN - SJF	REVISED -
PLOT DATE = 8/13/2024	CHECKED - SLD	REVISED -
	DATE - 8/13/2024	REVISED -

**STATE OF ILLINOIS
DEPARTMENT OF TRANSPORTATION**

**TRAFFIC CONTROL AND PROTECTION PLAN
STAGE 6**

SCALE: 1"=50' SHEET 63 OF 5>TFC SHEETS STA. TO STA.

F.A.I. RTE.	SECTION	COUNTY	TOTAL SHEETS	SHEET NO.
70	82-5V8-R-2	ST. CLAIR	254	97
			CONTRACT NO. 76K02	
ILLINOIS FED. AID PROJECT				

- LEGEND:**
- SIGN
 - DIRECTION OF TRAFFIC FLOW
 - TYPE II BARRICADES, DRUMS, OR VERTICAL BARRICADE
 - TYPE III BARRICADE
 - TEMPORARY CONCRETE BARRIER
 - IMPACT ATTENUATORS, TEMPORARY (NON-REDIRECTIVE, NARROW), TEST LEVEL 3
 - CONSTRUCTION AREA
 - ARROW BOARD

INSTALL TYPE III BARRICADES AT THE EXIT TERMINAL INTERSECTION OF THE EXCHANGE AVENUE EXIT RAMP

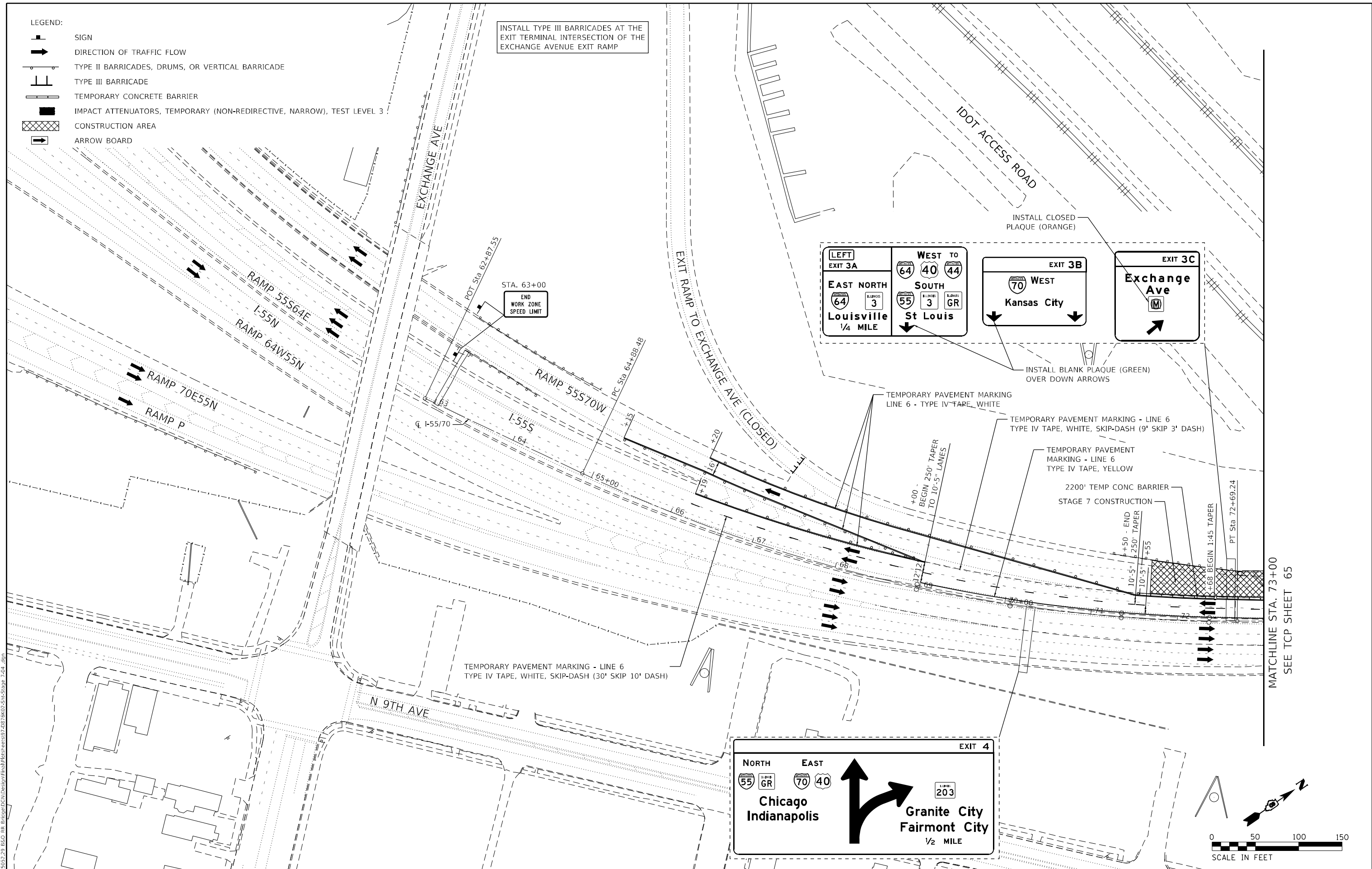

EXIT 3A: LEFT, EAST NORTH Louisville 1/4 MILE

EXIT 3B: WEST Kansas City

EXIT 3C: Exchange Ave

EXIT 4: NORTH Chicago Indianapolis, EAST Granite City Fairmont City 1/2 MILE

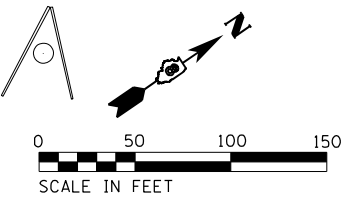

MATCHLINE STA. 73+00
SEE TCP SHEET 65

MODEL: 464611
FILE NAME: 211305229_B60_BR_B646611.dgn
PROJECT: 211305229_B60_BR_B646611.dgn

EFK Moen
Civil Engineering Design

USER NAME = zWaters	DESIGNED - SJF	REVISED -
PLOT SCALE = 100,0000' / in.	DRAWN - SJF	REVISED -
PLOT DATE = 8/13/2024	CHECKED - SLD	REVISED -
	DATE - 8/13/2024	REVISED -

**STATE OF ILLINOIS
DEPARTMENT OF TRANSPORTATION**

**TRAFFIC CONTROL AND PROTECTION PLAN
STAGE 7**

SCALE: 1"=50' SHEET 64 OF 5>TFC SHEETS STA. 62+87.55 TO STA. 73+00

F.A.I. RTE.	SECTION	COUNTY	TOTAL SHEETS	SHEET NO.
70	82-5V8-R-2	ST. CLAIR	254	98
CONTRACT NO. 76K02				
ILLINOIS FED. AID PROJECT				

- LEGEND:
- SIGN
 - DIRECTION OF TRAFFIC FLOW
 - TYPE II BARRICADES, DRUMS, OR VERTICAL BARRICADE
 - TYPE III BARRICADE
 - TEMPORARY CONCRETE BARRIER
 - IMPACT ATTENUATORS, TEMPORARY (NON-REDIRECTIVE, NARROW), TEST LEVEL 3
 - CONSTRUCTION AREA
 - ARROW BOARD

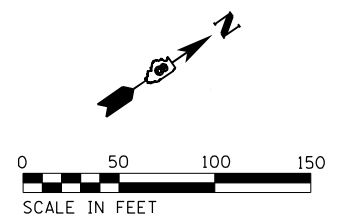
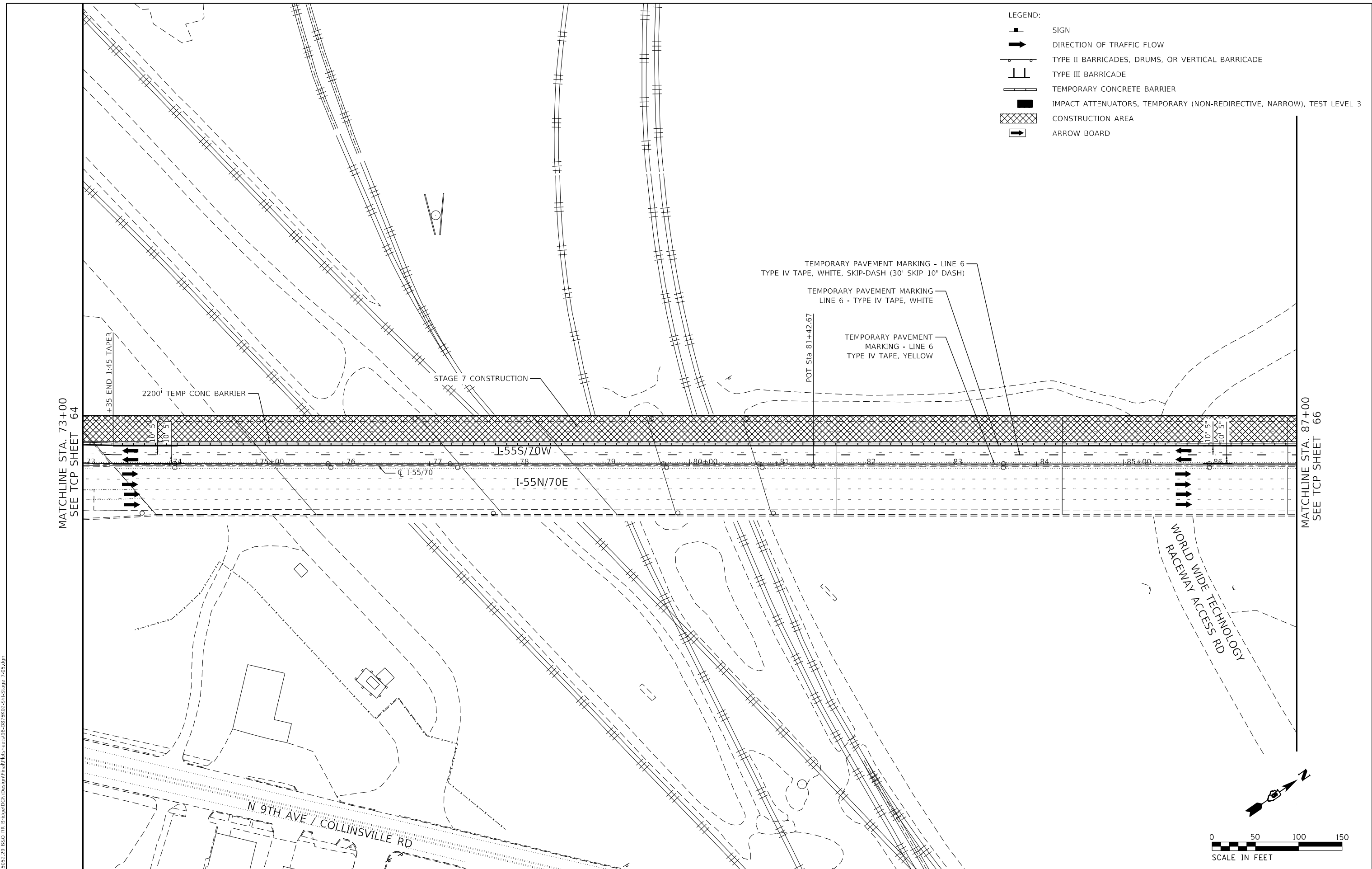

MODEL: 4646.dwg
 FILE NAME: Z:\13052.29 B60 BR Bridge\DC\Design\Plan\Traffic\82-5V8-R-2\Stage 7.dwg

EFK Moen
Civil Engineering Design

USER NAME = zWaters	DESIGNED - SJF	REVISED -
PLOT SCALE = 100,0000' / in.	DRAWN - SJF	REVISED -
PLOT DATE = 8/13/2024	CHECKED - SLD	REVISED -
	DATE - 8/13/2024	REVISED -









**STATE OF ILLINOIS
DEPARTMENT OF TRANSPORTATION**

**TRAFFIC CONTROL AND PROTECTION PLAN
STAGE 7**

SCALE: 1"=50' SHEET 65 OF 5>TFC SHEETS STA. 73+00 TO STA. 87+00

F.A.I. RTE.	SECTION	COUNTY	TOTAL SHEETS	SHEET NO.
70	82-5V8-R-2	ST. CLAIR	254	99
CONTRACT NO. 76K02			ILLINOIS FED. AID PROJECT	

LEGEND:

-  SIGN
-  DIRECTION OF TRAFFIC FLOW
-  TYPE II BARRICADES, DRUMS, OR VERTICAL BARRICADE
-  TYPE III BARRICADE
-  TEMPORARY CONCRETE BARRIER
-  IMPACT ATTENUATORS, TEMPORARY (NON-REDIRECTIVE, NARROW), TEST LEVEL 3
-  CONSTRUCTION AREA
-  ARROW BOARD

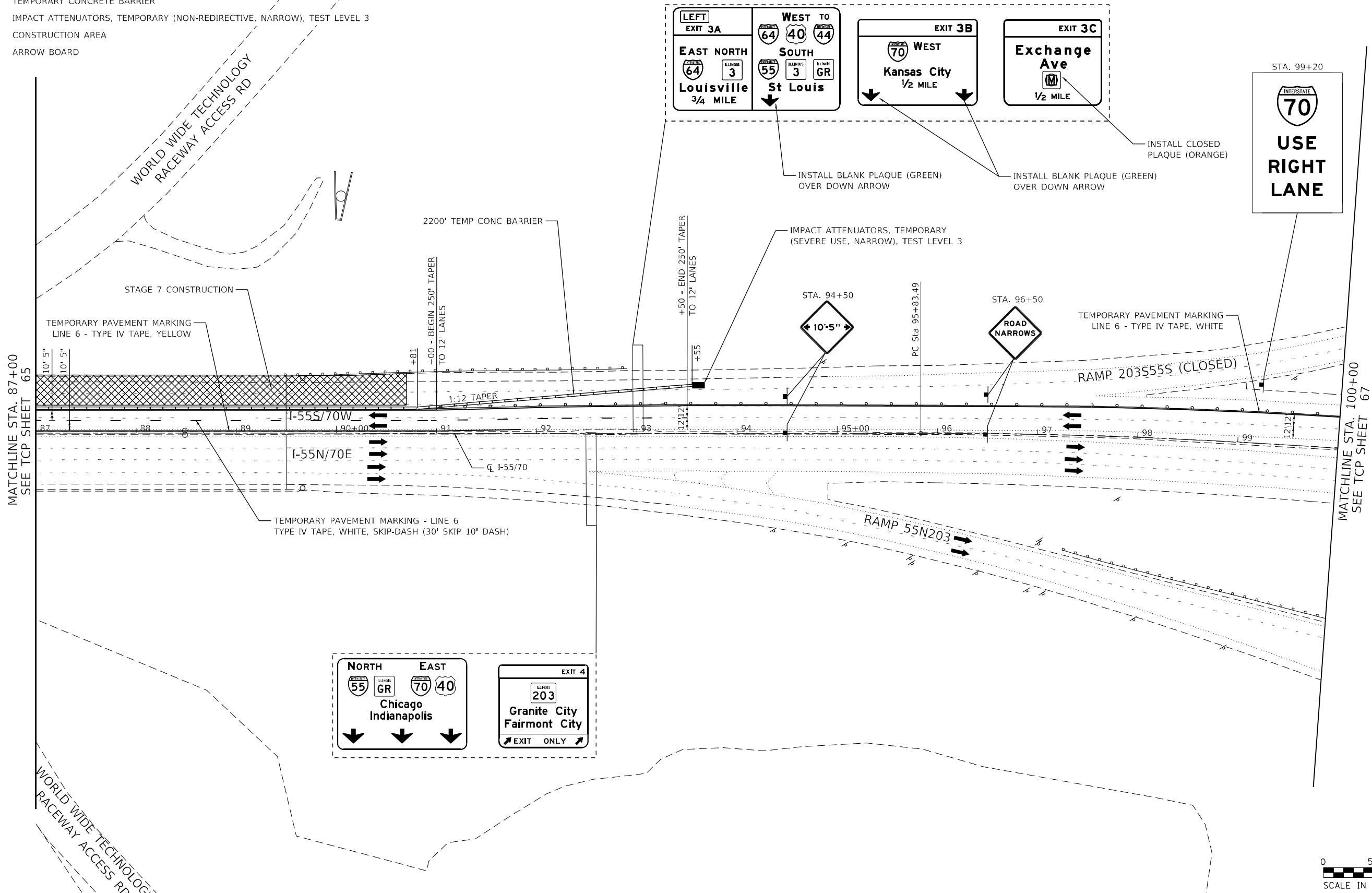

MODEL: d4646h
 FILE NAME: Z:\13052229_B60_BR_Bridge\DCN\Design\Final\Fetch\99-0876K02-Sht-Stage 7-06.dgn

EFK Moen
Civil Engineering Design

USER NAME = zWaters	DESIGNED - SJF	REVISED -
DRAWN - SJF	REVISOR -	
PLOT SCALE = 100,0000' / in.	CHECKED - SLD	REVISED -
PLOT DATE = 8/13/2024	DATE - 8/13/2024	REVISED -

**STATE OF ILLINOIS
DEPARTMENT OF TRANSPORTATION**





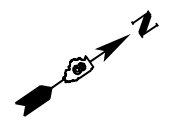
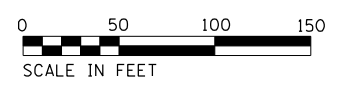

**TRAFFIC CONTROL AND PROTECTION PLAN
STAGE 7**

SCALE: 1"=50' SHEET 66 OF 5>TFC SHEETS STA. 87+00 TO STA. 100+00

F.A.I. RTE.	SECTION	COUNTY	TOTAL SHEETS	SHEET NO.
70	82-5V8-R-2	ST. CLAIR	254	100
CONTRACT NO. 76K02				
ILLINOIS FED. AID PROJECT				



LEGEND:

-  SIGN
-  DIRECTION OF TRAFFIC FLOW
-  TYPE II BARRICADES, DRUMS, OR VERTICAL BARRICADE
-  TYPE III BARRICADE
-  TEMPORARY CONCRETE BARRIER
-  IMPACT ATTENUATORS, TEMPORARY (NON-REDIRECTIVE, NARROW), TEST LEVEL 3
-  CONSTRUCTION AREA
-  ARROW BOARD

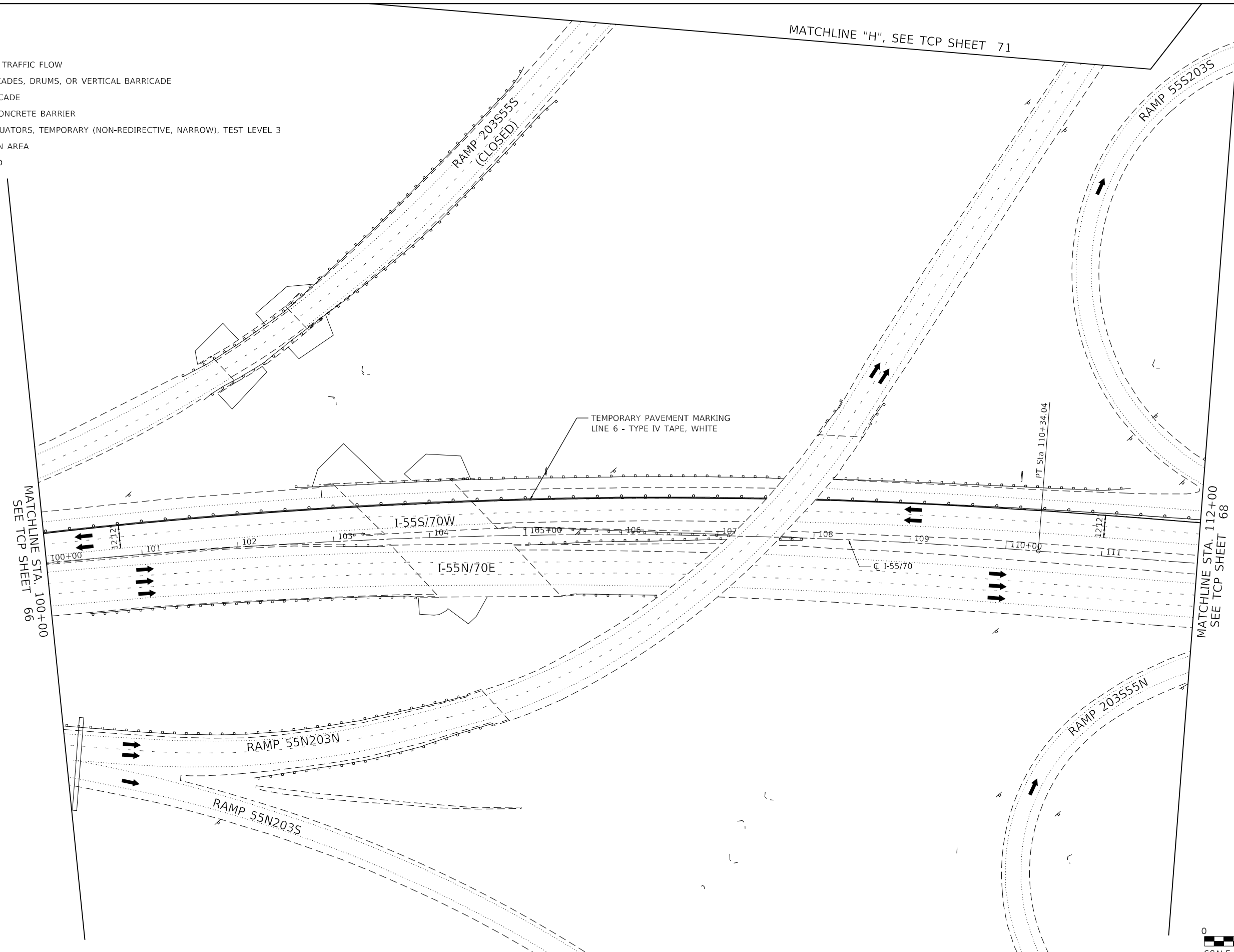

MODEL: 444444
 FILE NAME: Z:\130522\B60_BR_Bridge\DCN\Design\Final\Fetch\Sheet1100\0376K02-Sht-Stage_7.rvt.dgn

EFK Moen
Civil Engineering Design

USER NAME = zWaters	DESIGNED - SJF	REVISED -
PLOT SCALE = 100,0000' / in.	DRAWN - SJF	REVISED -
PLOT DATE = 8/13/2024	CHECKED - SLD	REVISED -
	DATE - 8/13/2024	REVISED -

**STATE OF ILLINOIS
DEPARTMENT OF TRANSPORTATION**









**TRAFFIC CONTROL AND PROTECTION PLAN
STAGE 7**

SCALE: 1"=50' SHEET 67 OF 5>TFC SHEETS STA. 100+00 TO STA. 112+00

F.A.I. RTE.	SECTION	COUNTY	TOTAL SHEETS	SHEET NO.
70	82-5V8-R-2	ST. CLAIR	254	101
CONTRACT NO. 76K02				

ILLINOIS FED. AID PROJECT

LEGEND:

-  SIGN
-  DIRECTION OF TRAFFIC FLOW
-  TYPE II BARRICADES, DRUMS, OR VERTICAL BARRICADE
-  TYPE III BARRICADE
-  TEMPORARY CONCRETE BARRIER
-  IMPACT ATTENUATORS, TEMPORARY (NON-REDIRECTIVE, NARROW), TEST LEVEL 3
-  CONSTRUCTION AREA
-  ARROW BOARD

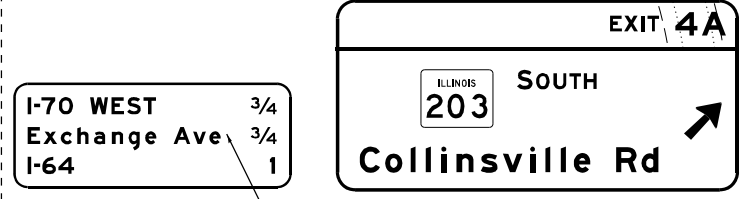
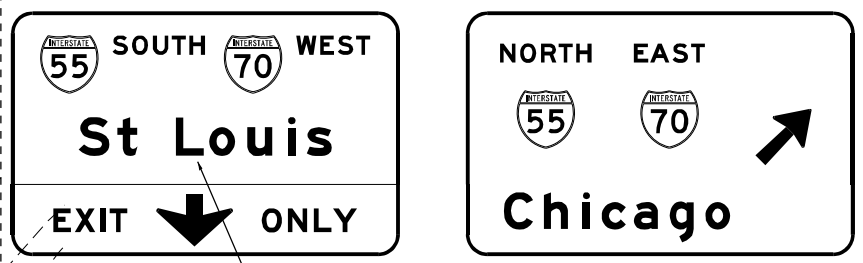

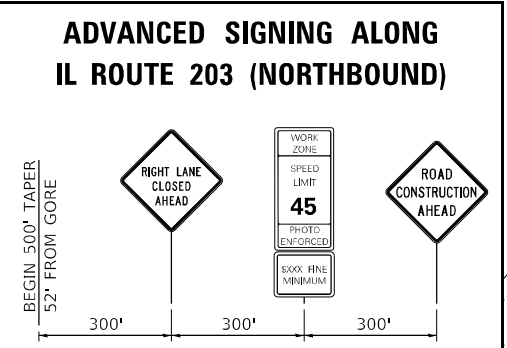

ADVANCED SIGNING ALONG IL ROUTE 203 (NORTHBOUND)

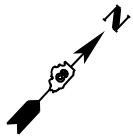
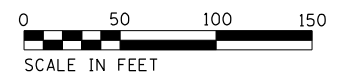

MATCHLINE STA. 112+00
SEE TCP SHEET 67

MATCHLINE STA. 126+00
SEE TCP SHEET 69



MODEL: 4646411
FILE NAME: 211305229_B60_BR_BridgeDesignFinalRevised101-037602-Sht-Stage_7-08.dgn

EFK Moen
Civil Engineering Design

USER NAME = zWaters	DESIGNED - SJF	REVISED -
PLOT SCALE = 100,000' / in.	DRAWN - SJF	REVISED -
PLOT DATE = 8/13/2024	CHECKED - SLD	REVISED -
	DATE - 8/13/2024	REVISED -

**STATE OF ILLINOIS
DEPARTMENT OF TRANSPORTATION**

**TRAFFIC CONTROL AND PROTECTION PLAN
STAGE 7**

SCALE: 1"=50' SHEET 68 OF 5>TFC SHEETS STA. 112+00 TO STA. 126+00

F.A.I. RTE.	SECTION	COUNTY	TOTAL SHEETS	SHEET NO.
70	82-5V8-R-2	ST. CLAIR	254	102
CONTRACT NO. 76K02				
ILLINOIS FED. AID PROJECT				

- LEGEND:
- SIGN
 - DIRECTION OF TRAFFIC FLOW
 - TYPE II BARRICADES, DRUMS, OR VERTICAL BARRICADE
 - TYPE III BARRICADE
 - TEMPORARY CONCRETE BARRIER
 - IMPACT ATTENUATORS, TEMPORARY (NON-REDIRECTIVE, NARROW), TEST LEVEL 3
 - CONSTRUCTION AREA
 - ARROW BOARD

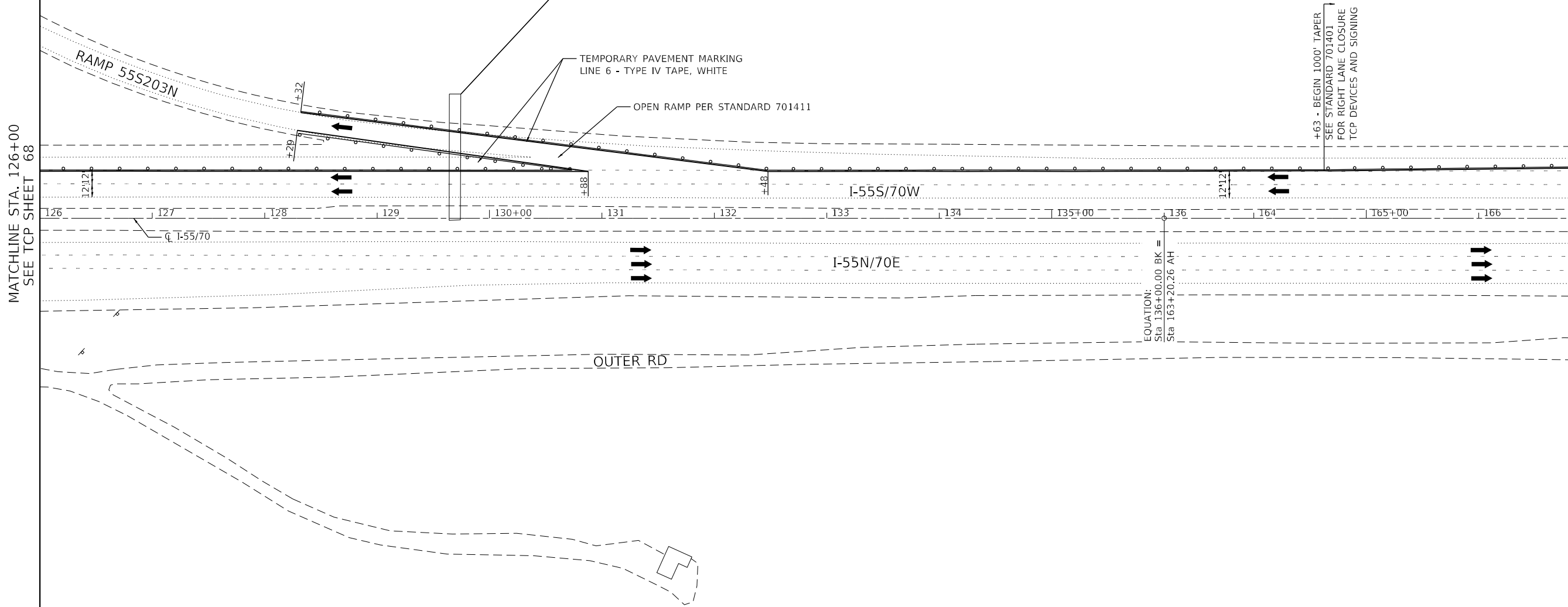
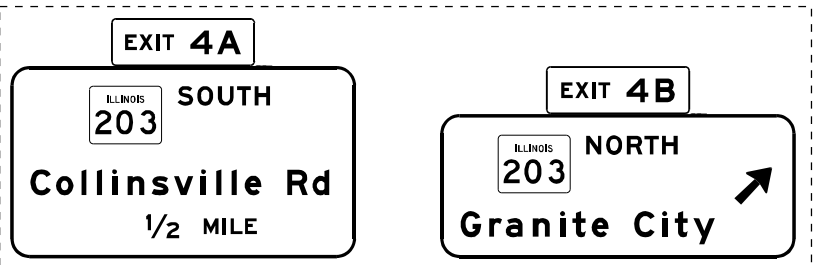

MATCHLINE STA. 126+00
SEE TCP SHEET 68

MATCHLINE STA. 167+00
SEE TCP SHEET 70

EQUATION:
Sta 136+00.00 BK =
Sta 163+20.26 AH

+63 - BEGIN 1000' TAPER
SEE STANDARD 701401
FOR RIGHT LANE CLOSURE
TCP DEVICES AND SIGNING

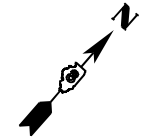
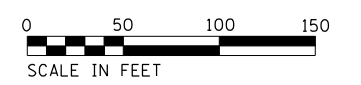

MODEL: 4464.dwg
 FILE NAME: Z:\13052229 B&O BR Bridge\DCN\Design\Final\BldgSheet\102-08376K02-Sht-Stage 7-09.dgn

EFK Moen
Civil Engineering Design

USER NAME = zWaters	DESIGNED - SJF	REVISED -
DRAWN - SJF	REVISIONS -	
PLOT SCALE = 100,0000' / in.	CHECKED - SLD	REVISED -
PLOT DATE = 8/13/2024	DATE - 8/13/2024	REVISED -









**STATE OF ILLINOIS
DEPARTMENT OF TRANSPORTATION**

**TRAFFIC CONTROL AND PROTECTION PLAN
STAGE 7**

SCALE: 1"=50' SHEET 69 OF 5>TFC SHEETS STA. 126+00 TO STA. 167+00

F.A.I. RTE.	SECTION	COUNTY	TOTAL SHEETS	SHEET NO.
70	82-5V8-R-2	ST. CLAIR	254	103
CONTRACT NO. 76K02			ILLINOIS FED. AID PROJECT	

LEGEND:

-  SIGN
-  DIRECTION OF TRAFFIC FLOW
-  TYPE II BARRICADES, DRUMS, OR VERTICAL BARRICADE
-  TYPE III BARRICADE
-  TEMPORARY CONCRETE BARRIER
-  IMPACT ATTENUATORS, TEMPORARY (NON-REDIRECTIVE, NARROW), TEST LEVEL 3
-  CONSTRUCTION AREA
-  ARROW BOARD

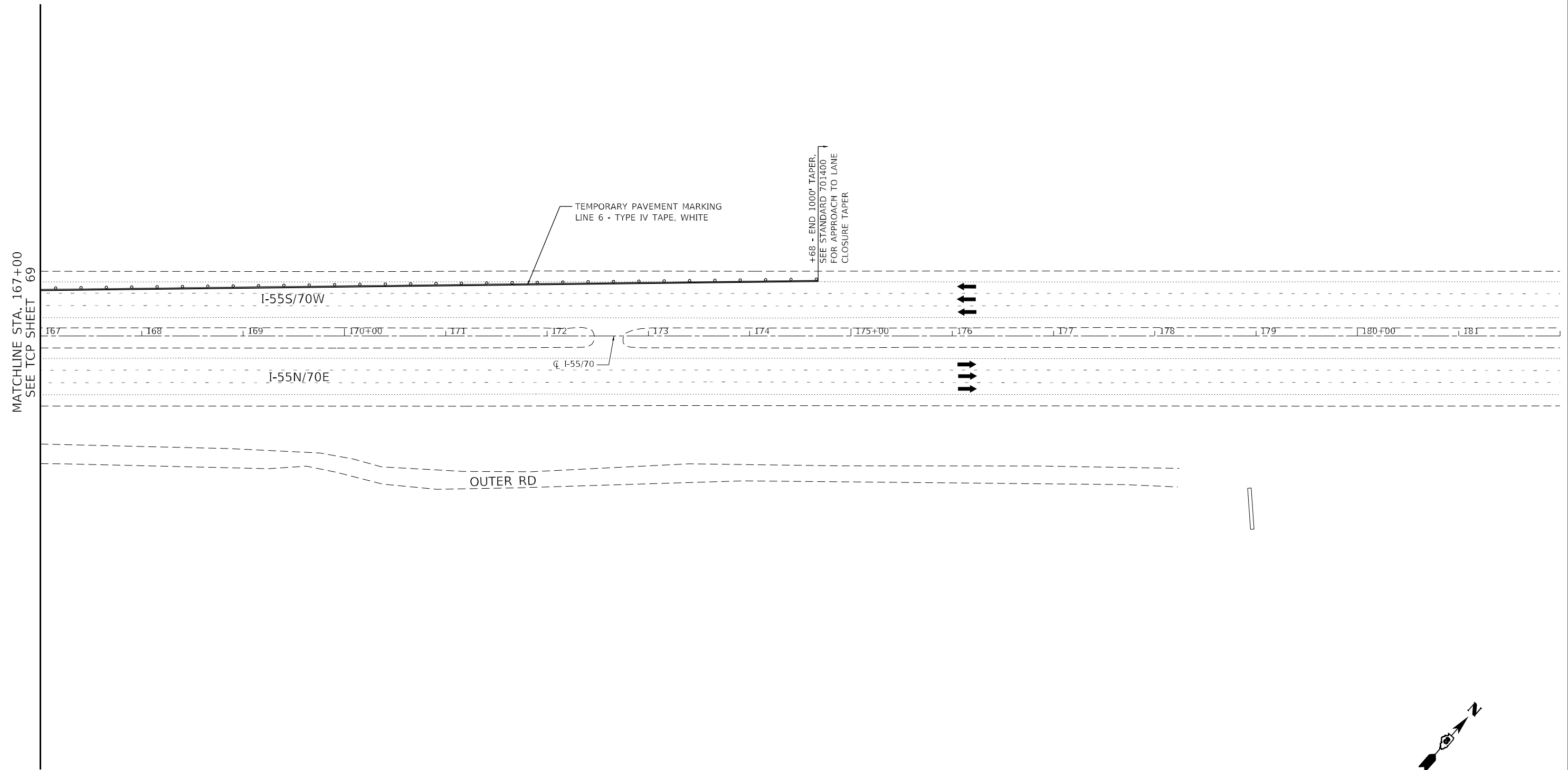

MODEL: d:\4\4\1
 FILE NAME: Z:\1305229 B&O BR Bridge\DCN\Design\Final\FinalSheet1103-0376K02-Sht-Stage 7-10.dgn

EFK Moen
Civil Engineering Design

USER NAME = zWaters	DESIGNED - SJF	REVISED -
DRAWN - SJF	REVISED -	
PLOT SCALE = 100,0000' / in.	CHECKED - SLD	REVISED -
PLOT DATE = 8/13/2024	DATE - 8/13/2024	REVISED -









**STATE OF ILLINOIS
DEPARTMENT OF TRANSPORTATION**

**TRAFFIC CONTROL AND PROTECTION PLAN
STAGE 7**

SCALE: 1"=50' SHEET 70 OF 5>TFC SHEETS STA. 167+00 TO STA. 182+00

F.A.I. RTE.	SECTION	COUNTY	TOTAL SHEETS	SHEET NO.
70	82-5V8-R-2	ST. CLAIR	254	104
CONTRACT NO. 76K02				
ILLINOIS FED. AID PROJECT				

LEGEND:

-  SIGN
-  DIRECTION OF TRAFFIC FLOW
-  TYPE II BARRICADES, DRUMS, OR VERTICAL BARRICADE
-  TYPE III BARRICADE
-  TEMPORARY CONCRETE BARRIER
-  IMPACT ATTENUATORS, TEMPORARY (NON-REDIRECTIVE, NARROW), TEST LEVEL 3
-  CONSTRUCTION AREA
-  ARROW BOARD

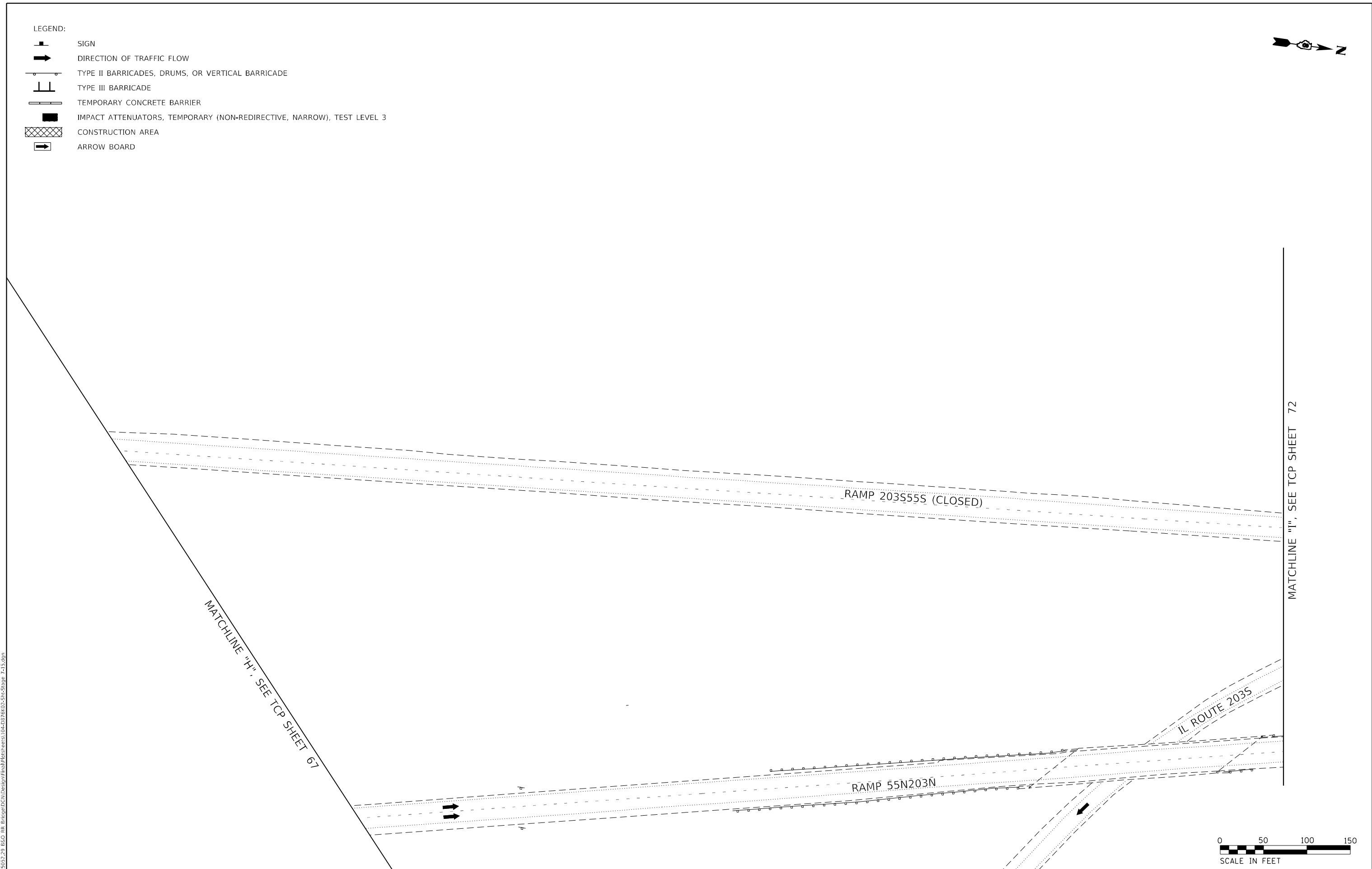

MATCHLINE "I", SEE TCP SHEET 72

MATCHLINE "H", SEE TCP SHEET 67



MODEL: d:\p4\h... FILE NAME: Z:\13052219_B&O_BR_Bridge\DCN\Design\Final\Fetch\Sheet1\04-0376K02-Sht-Stage_7-15.dgn

EFK Moen
Civil Engineering Design









USER NAME = zWaters	DESIGNED - SJF	REVISED -
DRAWN - SJF	REVISOR -	
PLOT SCALE = 100,0000' / in.	CHECKED - SLD	REVISED -
PLOT DATE = 8/13/2024	DATE - 8/13/2024	REVISED -

**STATE OF ILLINOIS
DEPARTMENT OF TRANSPORTATION**

**TRAFFIC CONTROL AND PROTECTION PLAN
STAGE 7**

SCALE: 1"=50' SHEET 71 OF 5>TFC SHEETS STA. TO STA.

F.A.I. RTE.	SECTION	COUNTY	TOTAL SHEETS	SHEET NO.
70	82-5V8-R-2	ST. CLAIR	254	105
CONTRACT NO. 76K02				
ILLINOIS FED. AID PROJECT				

- LEGEND:
-  SIGN
 -  DIRECTION OF TRAFFIC FLOW
 -  TYPE II BARRICADES, DRUMS, OR VERTICAL BARRICADE
 -  TYPE III BARRICADE
 -  TEMPORARY CONCRETE BARRIER
 -  IMPACT ATTENUATORS, TEMPORARY (NON-REDIRECTIVE, NARROW), TEST LEVEL 3
 -  CONSTRUCTION AREA
 -  ARROW BOARD

ADVANCED SIGNING ALONG IL ROUTE 203 (SOUTHBOUND)

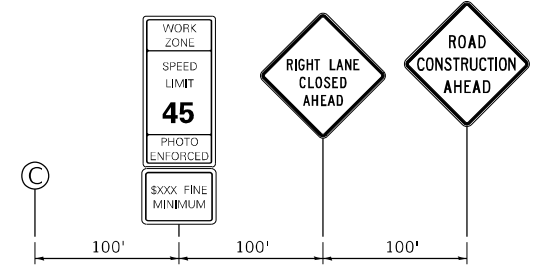

NOTE:
1. ADVANCED WARNING SIGNS SHALL BE PLACED ON EITHER SIDE OF SOUTHBOUND IL ROUTE 203.

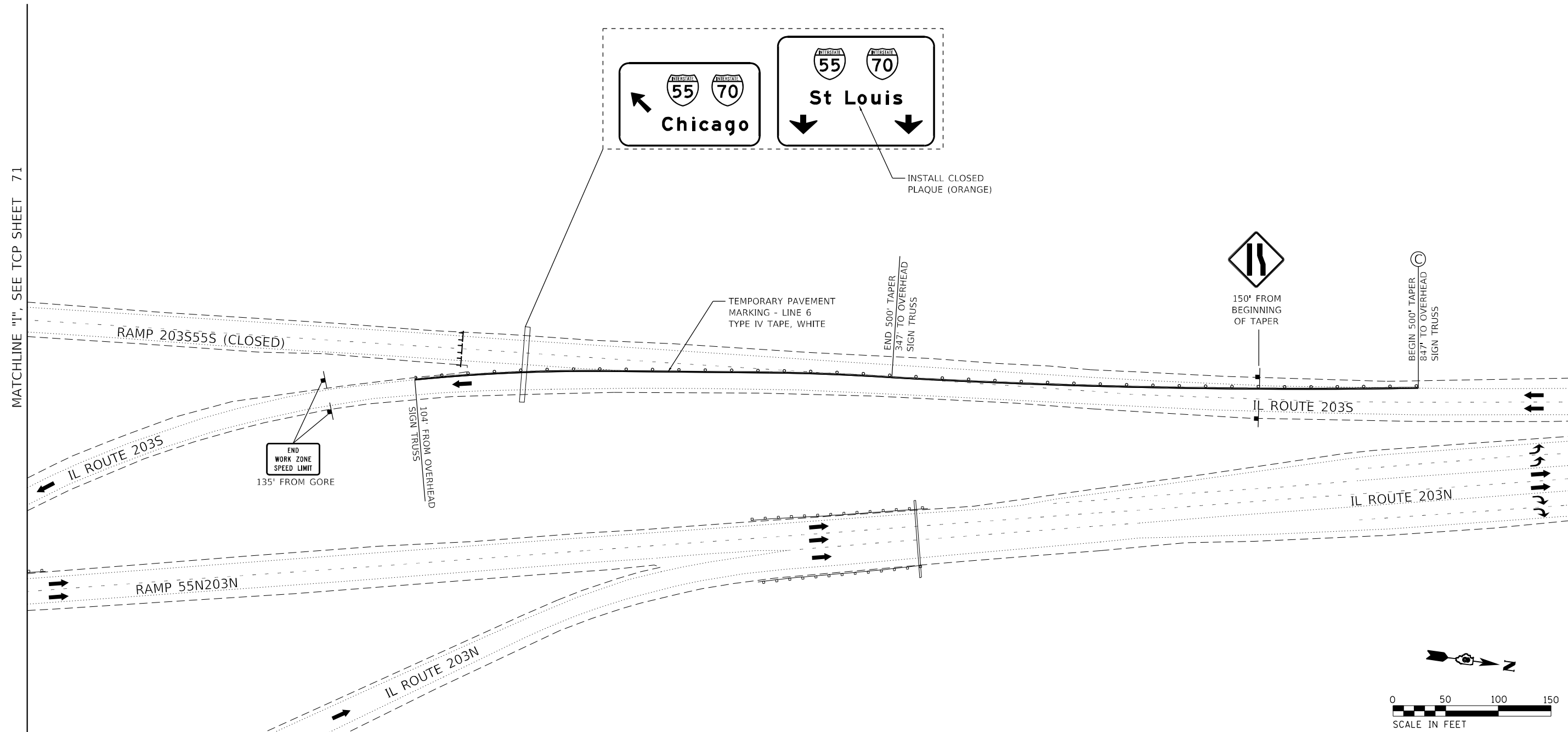

MODEL: d:\464\h
 FILE NAME: 211203229 B&O BR Bridge\DCN\Design\Final\Sheet\105-0376K02-Sht-Stage 7-16.dgn

EFK Moen
Civil Engineering Design

USER NAME = zWaters	DESIGNED - SJF	REVISED -
PLOT SCALE = 100,0000' / in.	DRAWN - SJF	REVISED -
PLOT DATE = 8/13/2024	CHECKED - SLD	REVISED -
	DATE - 8/13/2024	REVISED -

STATE OF ILLINOIS
DEPARTMENT OF TRANSPORTATION

TRAFFIC CONTROL AND PROTECTION PLAN
STAGE 7

SCALE: 1"=50' SHEET 72 OF 5>TFC SHEETS STA. TO STA.

F.A.I. RTE.	SECTION	COUNTY	TOTAL SHEETS	SHEET NO.
70	82-5V8-R-2	ST. CLAIR	254	106
ILLINOIS FED. AID PROJECT			CONTRACT NO. 76K02	

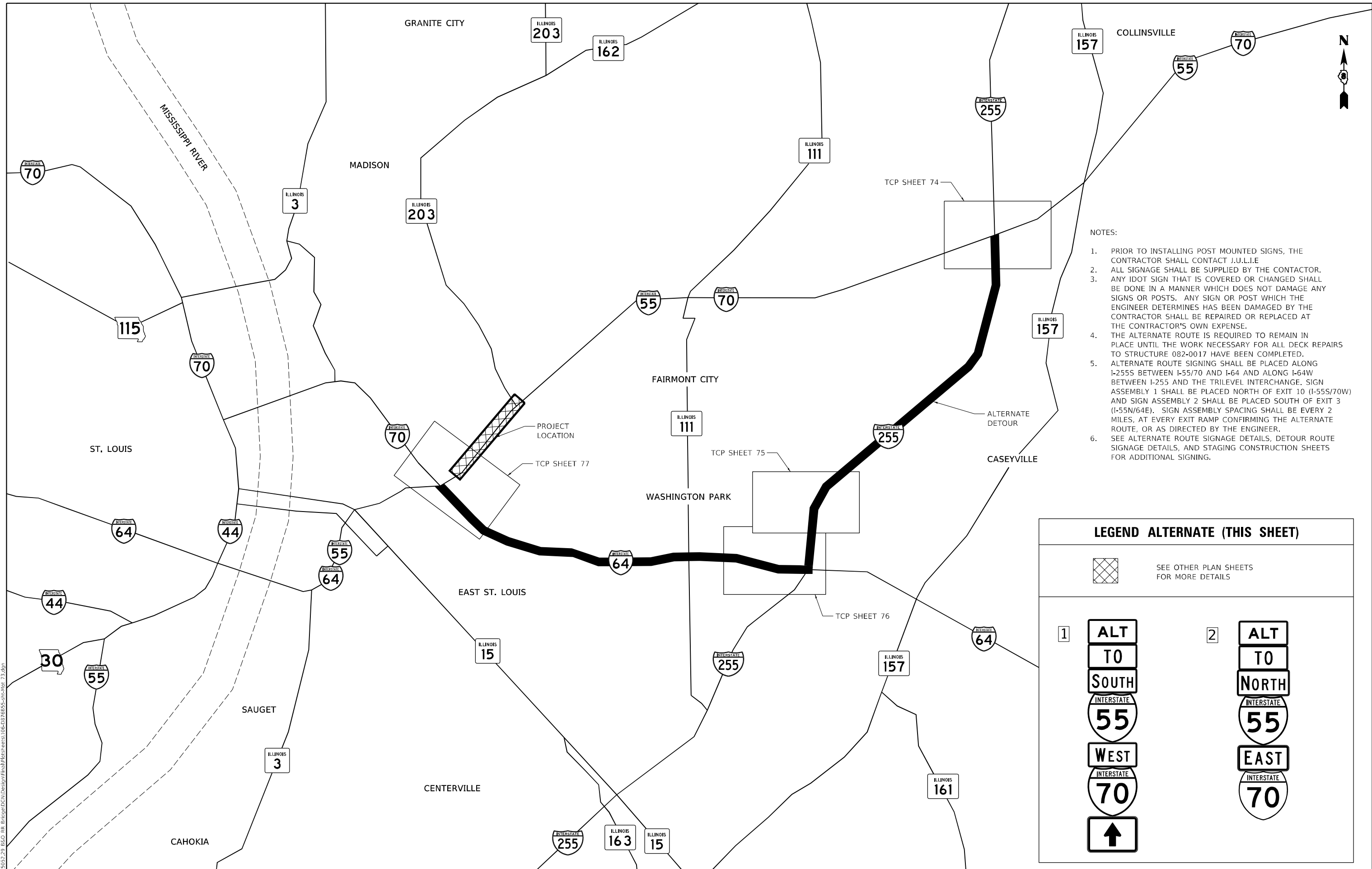

- NOTES:
1. PRIOR TO INSTALLING POST MOUNTED SIGNS, THE CONTRACTOR SHALL CONTACT J.U.L.I.E
 2. ALL SIGNAGE SHALL BE SUPPLIED BY THE CONTRACTOR.
 3. ANY IDOT SIGN THAT IS COVERED OR CHANGED SHALL BE DONE IN A MANNER WHICH DOES NOT DAMAGE ANY SIGNS OR POSTS. ANY SIGN OR POST WHICH THE ENGINEER DETERMINES HAS BEEN DAMAGED BY THE CONTRACTOR SHALL BE REPAIRED OR REPLACED AT THE CONTRACTOR'S OWN EXPENSE.
 4. THE ALTERNATE ROUTE IS REQUIRED TO REMAIN IN PLACE UNTIL THE WORK NECESSARY FOR ALL DECK REPAIRS TO STRUCTURE 082-0017 HAVE BEEN COMPLETED.
 5. ALTERNATE ROUTE SIGNING SHALL BE PLACED ALONG I-255S BETWEEN I-55/70 AND I-64 AND ALONG I-64W BETWEEN I-255 AND THE TRILEVEL INTERCHANGE. SIGN ASSEMBLY 1 SHALL BE PLACED NORTH OF EXIT 10 (I-55S/70W) AND SIGN ASSEMBLY 2 SHALL BE PLACED SOUTH OF EXIT 3 (I-55N/64E). SIGN ASSEMBLY SPACING SHALL BE EVERY 2 MILES, AT EVERY EXIT RAMP CONFIRMING THE ALTERNATE ROUTE, OR AS DIRECTED BY THE ENGINEER.
 6. SEE ALTERNATE ROUTE SIGNAGE DETAILS, DETOUR ROUTE SIGNAGE DETAILS, AND STAGING CONSTRUCTION SHEETS FOR ADDITIONAL SIGNING.

LEGEND ALTERNATE (THIS SHEET)

SEE OTHER PLAN SHEETS FOR MORE DETAILS

1

2

EFK Moen
Civil Engineering Design

USER NAME = zWaters	DESIGNED - SJF	REVISED -
	DRAWN - SJF	REVISED -
PLOT SCALE = 20,0000 * / in.	CHECKED - SLD	REVISED -
PLOT DATE = 8/13/2024	DATE - 8/13/2024	REVISED -

**STATE OF ILLINOIS
DEPARTMENT OF TRANSPORTATION**

**TRAFFIC CONTROL AND PROTECTION PLAN
ALTERNATE ROUTE SIGNAGE DETAIL AND KEY SHEET**

F.A.I. RTE.	SECTION	COUNTY	TOTAL SHEETS	SHEET NO.
70	82-5V8-R-2	ST. CLAIR	254	107
CONTRACT NO. 76K02				
ILLINOIS FED. AID PROJECT				

SCALE: 1"=200' SHEET 73 OF 5>TFC SHEETS STA. TO STA.

MODEL: D:\efk\h... FILE NAME: 2413052-29_B60_BR_Bridge\DCN\Design\Final\FiberSheet3106-0376655-shd-Mat-73.dgn



MODEL: D:\efk\...
 FILE NAME: 2413052.29_B&O_BR_Bridge\DC\Design\Plan\Traffic\74.dgn

EFK Moen
Civil Engineering Design

USER NAME = zWaters	DESIGNED - SJF	REVISED -
DRAWN - SJF	REVISOR -	
PLOT SCALE = 400,000' / in.	CHECKED - SLD	REVISOR -
PLOT DATE = 8/13/2024	DATE - 8/13/2024	REVISOR -

**STATE OF ILLINOIS
DEPARTMENT OF TRANSPORTATION**

**TRAFFIC CONTROL AND PROTECTION PLAN
ALTERNATE ROUTE SIGNAGE DETAIL**

F.A.I. RTE.	SECTION	COUNTY	TOTAL SHEETS	SHEET NO.
70	82-5V8-R-2	ST. CLAIR	254	108
CONTRACT NO. 76K02			ILLINOIS FED. AID PROJECT	

SCALE: 1"=200' SHEET 74 OF 5>TFC SHEETS STA. TO STA.





I 255S
I 255N

N 81 ST

I 255S C-D LANE
I 255S
I 255N C-D LANE
I 255N

MATCHLINE "AA", SEE TCP SHEET 76

- LEGEND:
-  SIGN
 -  TYPE III BARRICADE
 -  TRAFFIC FLOW

MODEL: D:\efk\h
FILE NAME: Z:\1305229 B&O BR Bridge\DCN\Design\Final\Fetch\sheet1108-0376855-eh-Mbr-75.dgn



USER NAME = zWaters	DESIGNED - SJF	REVISED -
	DRAWN - SJF	REVISED -
PLOT SCALE = 400,0000' / in.	CHECKED - SLD	REVISED -
PLOT DATE = 8/13/2024	DATE - 8/13/2024	REVISED -

STATE OF ILLINOIS
DEPARTMENT OF TRANSPORTATION

TRAFFIC CONTROL AND PROTECTION PLAN
ALTERNATE ROUTE SIGNAGE DETAIL

SCALE: 1"=200' SHEET 75 OF 5>TFC SHEETS STA. TO STA.

F.A.I. RTE.	SECTION	COUNTY	TOTAL SHEETS	SHEET NO.
70	82-5V8-R-2	ST. CLAIR	254	109
CONTRACT NO. 76K02				
ILLINOIS FED. AID PROJECT				

MATCHLINE "AA", SEE TCP SHEET 75

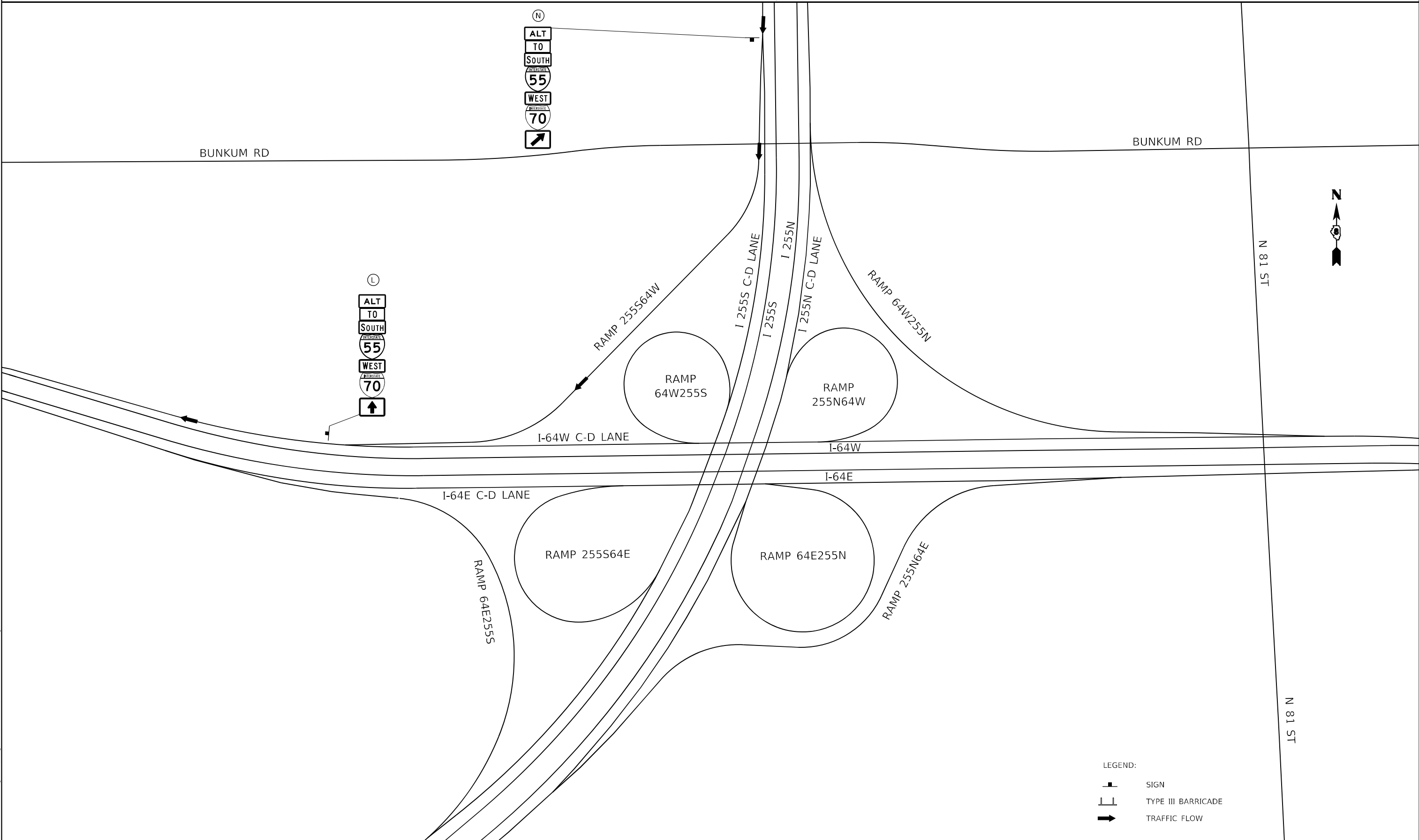

- LEGEND:
- SIGN
 - TYPE III BARRICADE
 - TRAFFIC FLOW

MODEL: D:\efk\h
 FILE NAME: Z:\1305229_B60_BR_Bridge\DCN\Design\Final\FetchSheet1109-0376855.dwg-Mat_75.dgn

EFK Moen
Civil Engineering Design



USER NAME = zWaters	DESIGNED - SJF	REVISED -
	DRAWN - SJF	REVISED -
PLOT SCALE = 400,0000' / in.	CHECKED - SLD	REVISED -
PLOT DATE = 8/13/2024	DATE - 8/13/2024	REVISED -

**STATE OF ILLINOIS
DEPARTMENT OF TRANSPORTATION**

**TRAFFIC CONTROL AND PROTECTION PLAN
ALTERNATE ROUTE SIGNAGE DETAIL**

SCALE: 1"=200' SHEET 76 OF 5>TFC SHEETS STA. TO STA.

F.A.I. RTE.	SECTION	COUNTY	TOTAL SHEETS	SHEET NO.
70	82-5V8-R-2	ST. CLAIR	254	110
ILLINOIS FED. AID PROJECT			CONTRACT NO. 76K02	

- LEGEND:
-  SIGN
 -  TYPE III BARRICADE
 -  TRAFFIC FLOW

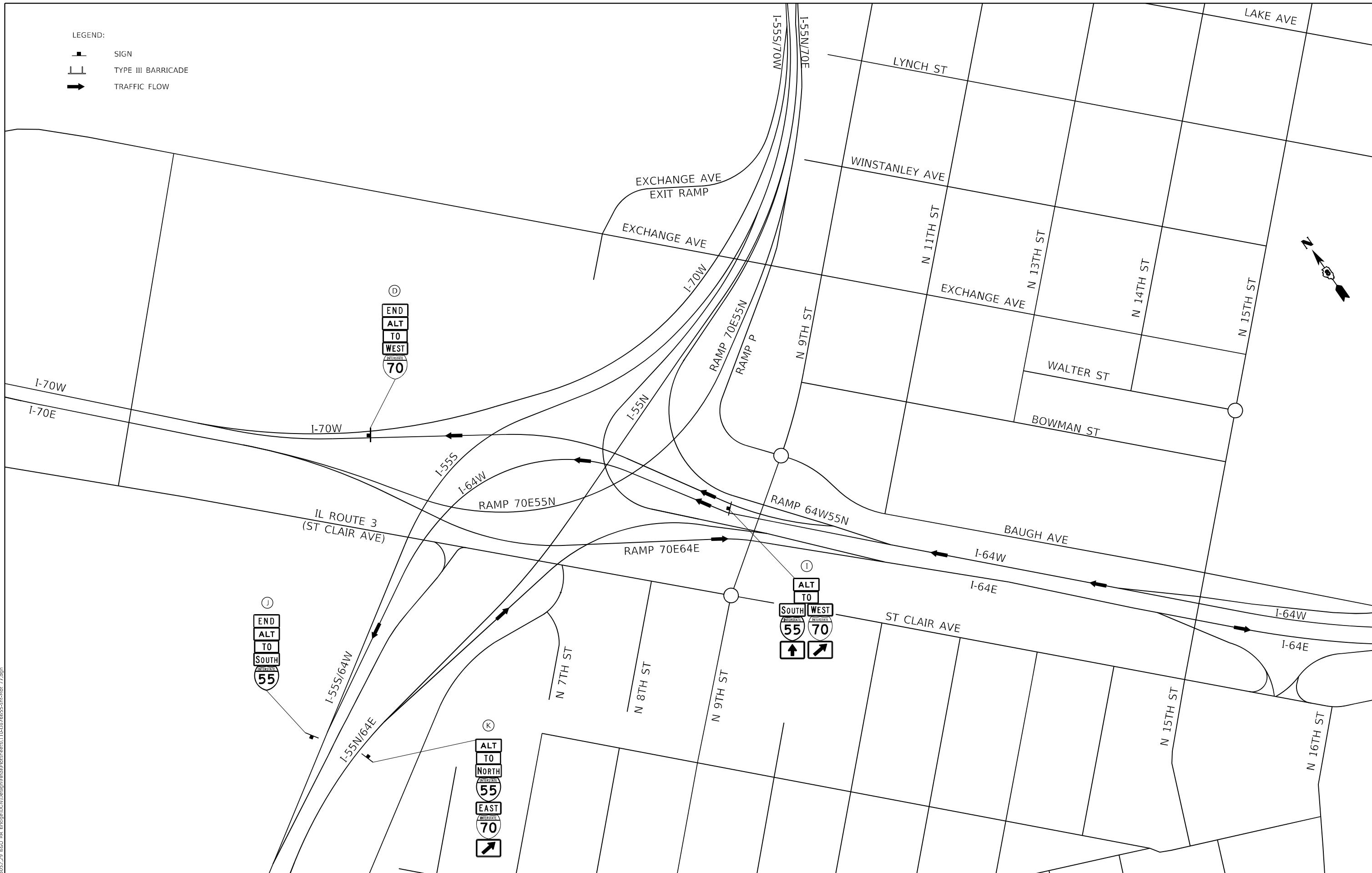

MODEL: D:\efk\h
 FILE NAME: Z:\13052-29_B&O_BR_Bridge\DCN\Design\Final\Fiber\Sheet110.dwg
 8/13/2024 10:03:55 AM zWaters 77.dgn

EFK Moen
Civil Engineering Design

USER NAME = zWaters	DESIGNED - SJF	REVISED -
	DRAWN - SJF	REVISED -
PLOT SCALE = 400,0000' / in.	CHECKED - SLD	REVISED -
PLOT DATE = 8/13/2024	DATE - 8/13/2024	REVISED -

**STATE OF ILLINOIS
DEPARTMENT OF TRANSPORTATION**

**TRAFFIC CONTROL AND PROTECTION PLAN
ALTERNATE ROUTE SIGNAGE DETAIL**

SCALE: 1"=200' SHEET 77 OF 5>TFC SHEETS STA. TO STA.

F.A.I. RTE.	SECTION	COUNTY	TOTAL SHEETS	SHEET NO.
70	82-5V8-R-2	ST. CLAIR	254	111
CONTRACT NO. 76K02				
ILLINOIS FED. AID PROJECT				

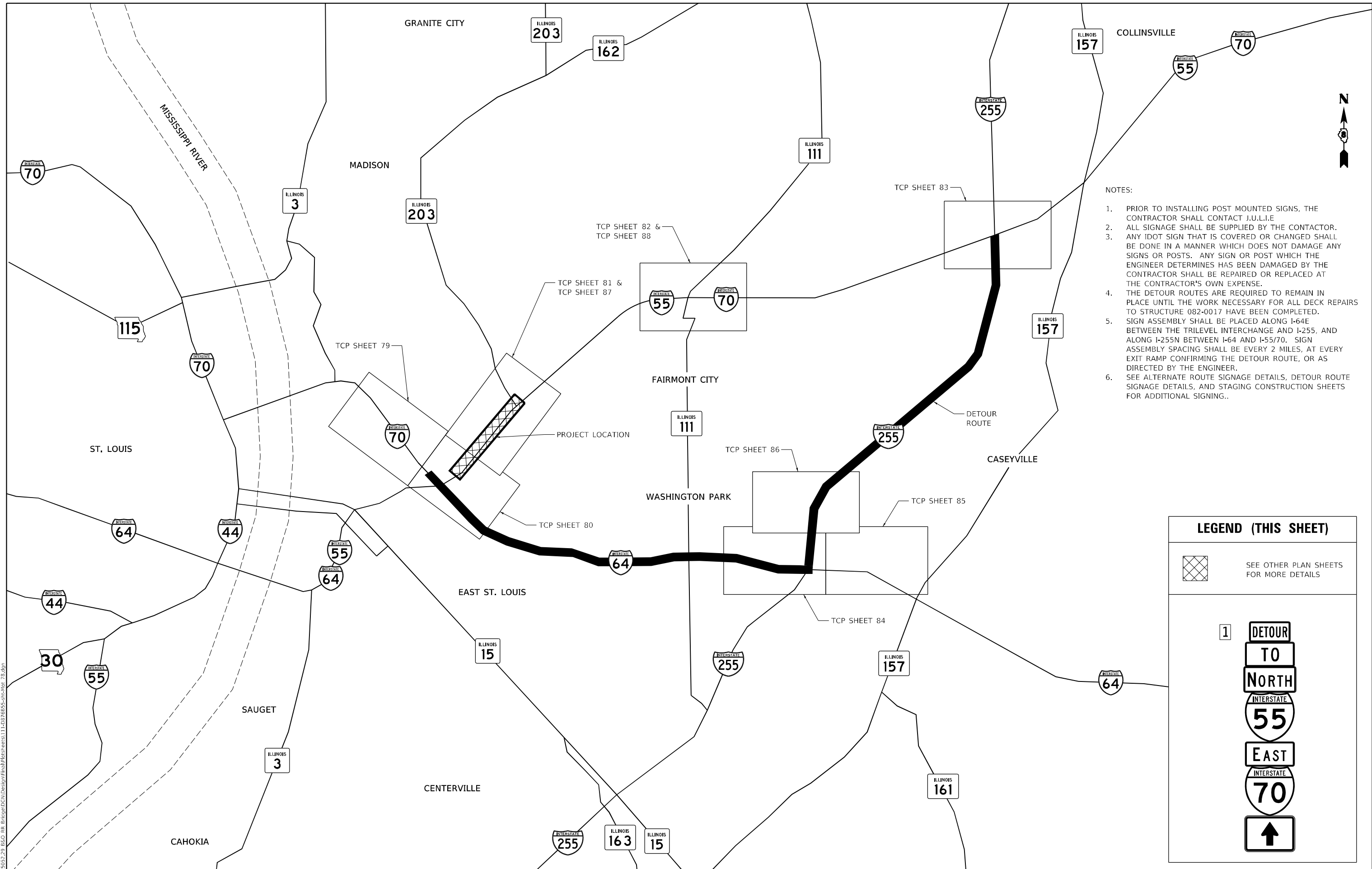

- NOTES:
1. PRIOR TO INSTALLING POST MOUNTED SIGNS, THE CONTRACTOR SHALL CONTACT J.U.L.I.E
 2. ALL SIGNAGE SHALL BE SUPPLIED BY THE CONTRACTOR.
 3. ANY IDOT SIGN THAT IS COVERED OR CHANGED SHALL BE DONE IN A MANNER WHICH DOES NOT DAMAGE ANY SIGNS OR POSTS. ANY SIGN OR POST WHICH THE ENGINEER DETERMINES HAS BEEN DAMAGED BY THE CONTRACTOR SHALL BE REPAIRED OR REPLACED AT THE CONTRACTOR'S OWN EXPENSE.
 4. THE DETOUR ROUTES ARE REQUIRED TO REMAIN IN PLACE UNTIL THE WORK NECESSARY FOR ALL DECK REPAIRS TO STRUCTURE 082-0017 HAVE BEEN COMPLETED.
 5. SIGN ASSEMBLY SHALL BE PLACED ALONG I-64 BETWEEN THE TRILEVEL INTERCHANGE AND I-255, AND ALONG I-255N BETWEEN I-64 AND I-55/70. SIGN ASSEMBLY SPACING SHALL BE EVERY 2 MILES, AT EVERY EXIT RAMP CONFIRMING THE DETOUR ROUTE, OR AS DIRECTED BY THE ENGINEER.
 6. SEE ALTERNATE ROUTE SIGNAGE DETAILS, DETOUR ROUTE SIGNAGE DETAILS, AND STAGING CONSTRUCTION SHEETS FOR ADDITIONAL SIGNING..

LEGEND (THIS SHEET)

 SEE OTHER PLAN SHEETS FOR MORE DETAILS

1 

MODEL Path: \\...
 FILE NAME: 20130522_09_B60_BR_BridgeDCNDesign\Final\FetchSheet111-08376655.dwg; Mod: 78.dwg

EFK Moen
Civil Engineering Design

USER NAME = zWaters	DESIGNED - SJF	REVISED -
	DRAWN - SJF	REVISED -
PLOT SCALE = 20,0000 * / in.	CHECKED - SLD	REVISED -
PLOT DATE = 8/13/2024	DATE - 8/13/2024	REVISED -

**STATE OF ILLINOIS
DEPARTMENT OF TRANSPORTATION**



**TRAFFIC CONTROL AND PROTECTION PLAN
DETOUR ROUTE SIGNAGE DETAIL & KEY SHEET FOR STAGES 1 - 4A**

SCALE: 1"=200' SHEET 78 OF 5>TFC SHEETS STA. TO STA.

F.A.I. RTE.	SECTION	COUNTY	TOTAL SHEETS	SHEET NO.
70	82-5V8-R-2	ST. CLAIR	254	112
CONTRACT NO. 76K02				
ILLINOIS FED. AID PROJECT				

MATCHLINE "CC", SEE TCP SHEET 81



- LEGEND:
-  SIGN
 -  TYPE III BARRICADE
 -  TRAFFIC FLOW

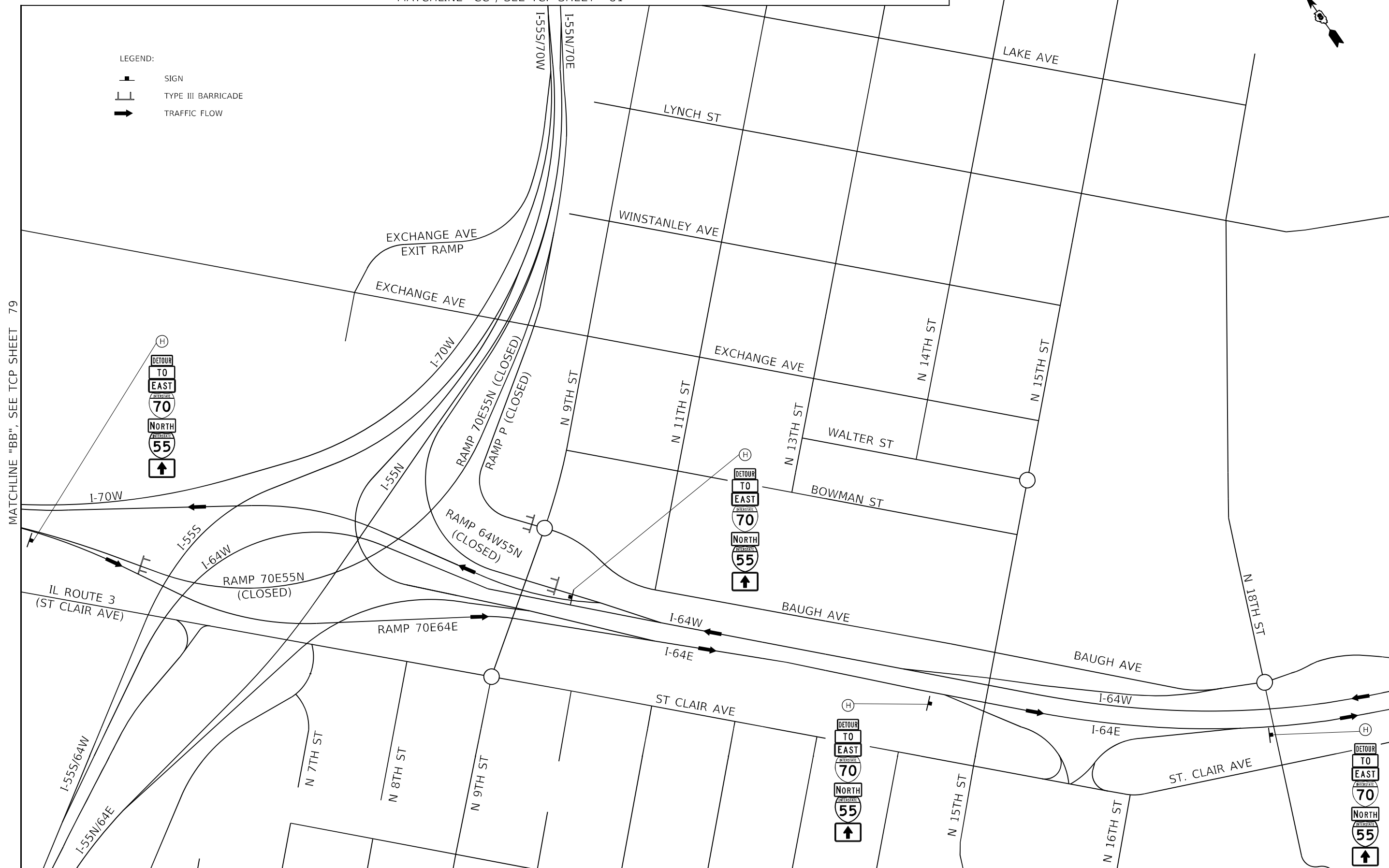

MATCHLINE "BB", SEE TCP SHEET 79

MODEL: D:\p\h\...
FILE NAME: 2113032-29_B&O_BR_Bridge\DCN\Design\Final\FB\TFC\Sheet113-20376655.dwg-Mat_80.dgn

EFK Moen
Civil Engineering Design

USER NAME = zWaters	DESIGNED - SJF	REVISED -
	DRAWN - SJF	REVISED -
PLOT SCALE = 400,0000' / in.	CHECKED - SLD	REVISED -
PLOT DATE = 8/13/2024	DATE - 8/13/2024	REVISED -

STATE OF ILLINOIS
DEPARTMENT OF TRANSPORTATION

TRAFFIC CONTROL AND PROTECTION PLAN
STAGES 1 - 4A DETOUR SIGNAGE DETAIL

SCALE: 1"=200'
SHEET 80 OF 5>TFC SHEETS STA. TO STA.

F.A.I. RTE.	SECTION	COUNTY	TOTAL SHEETS	SHEET NO.
70	82-5V8-R-2	ST. CLAIR	254	114
CONTRACT NO. 76K02				
ILLINOIS FED. AID PROJECT				

LEGEND:

-  SIGN
-  TYPE III BARRICADE
-  TRAFFIC FLOW

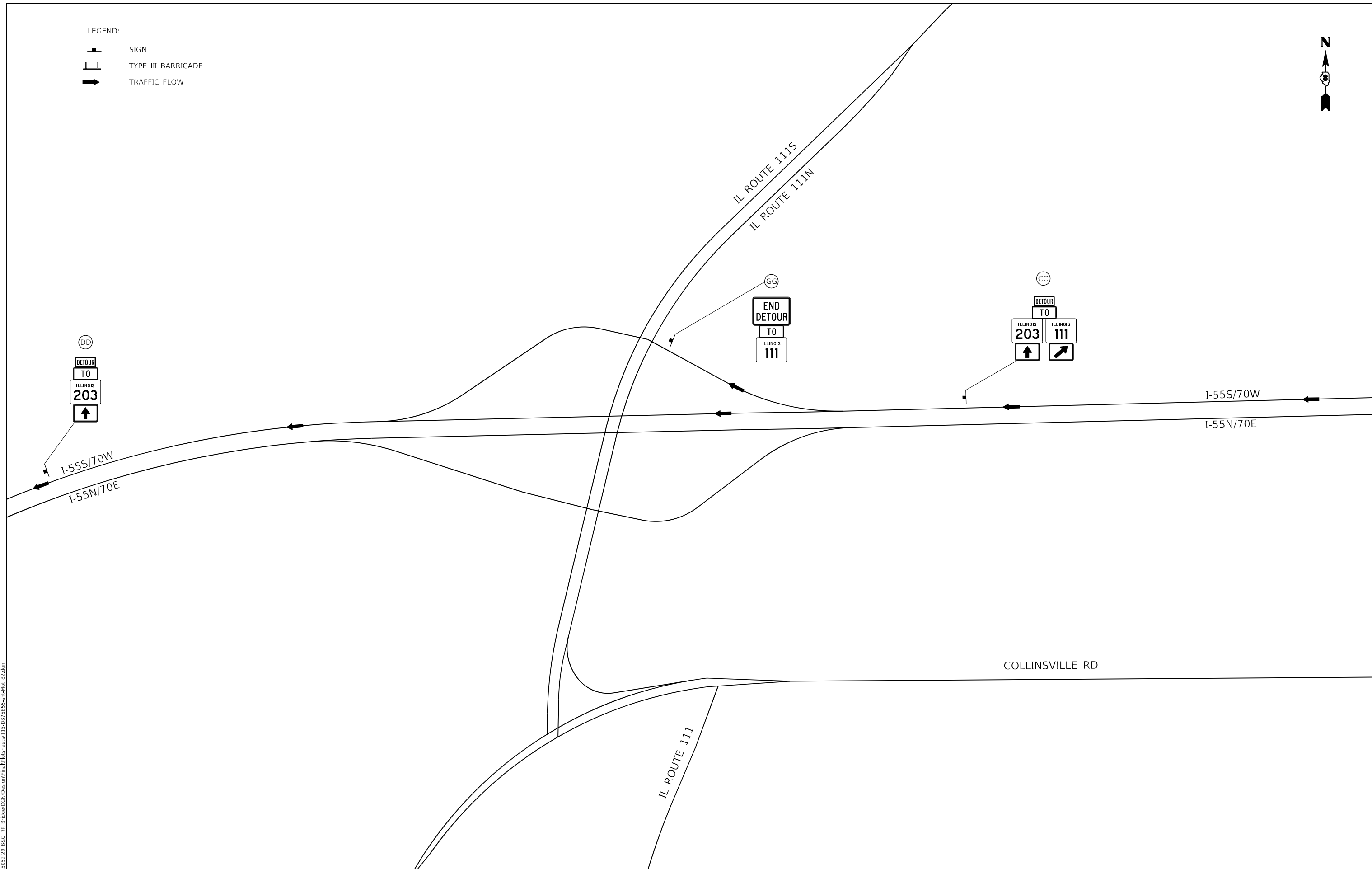

MODEL: D:\efk\h
 FILE NAME: Z:\13052.29 B&O BR Bridge\DCN\Design\Final\Fetch\Sheet115-00376855.dwg-Mat 82.dgn

EFK Moen
Civil Engineering Design

USER NAME = zWaters	DESIGNED - SJF	REVISED -
DRAWN - SJF	CHECKED - SLD	REVISED -
PLOT SCALE = 400,0000' / in.	DATE - 8/13/2024	REVISED -
PLOT DATE = 8/13/2024		



**STATE OF ILLINOIS
DEPARTMENT OF TRANSPORTATION**

**TRAFFIC CONTROL AND PROTECTION PLAN
STAGES 1 - 4A DETOUR SIGNAGE DETAIL**

SCALE: 1"=200' SHEET 82 OF 82 TFC SHEETS STA. TO STA.

F.A.I. RTE.	SECTION	COUNTY	TOTAL SHEETS	SHEET NO.
70	82-5V8-R-2	ST. CLAIR	254	116
CONTRACT NO. 76K02			ILLINOIS FED. AID PROJECT	



- LEGEND:
-  SIGN
 -  TYPE III BARRICADE
 -  TRAFFIC FLOW

MODEL: D:\efk\moen\civil\76k02\29_B&C_BR_Bridge\DCN\Design\Final\Fetch\sheet116.dwg
 FILE NAME: 20240813_29_B&C_BR_Bridge\DCN\Design\Final\Fetch\sheet116.dwg

EFK Moen
Civil Engineering Design

USER NAME = zWaters	DESIGNED - SJF	REVISED -
	DRAWN - SJF	REVISED -
PLOT SCALE = 400,0000' / in.	CHECKED - SLD	REVISED -
PLOT DATE = 8/13/2024	DATE - 8/13/2024	REVISED -

**STATE OF ILLINOIS
DEPARTMENT OF TRANSPORTATION**

**TRAFFIC CONTROL AND PROTECTION PLAN
STAGES 1 - 4A DETOUR SIGNAGE DETAIL**

SCALE: 1"=200' SHEET 83 OF S>TFC SHEETS STA. TO STA.

F.A.I. RTE.	SECTION	COUNTY	TOTAL SHEETS	SHEET NO.
70	82-5V8-R-2	ST. CLAIR	254	117
CONTRACT NO. 76K02				
ILLINOIS FED. AID PROJECT				



MATCHLINE "EE", SEE TCP SHEET 86

BUNKUM RD

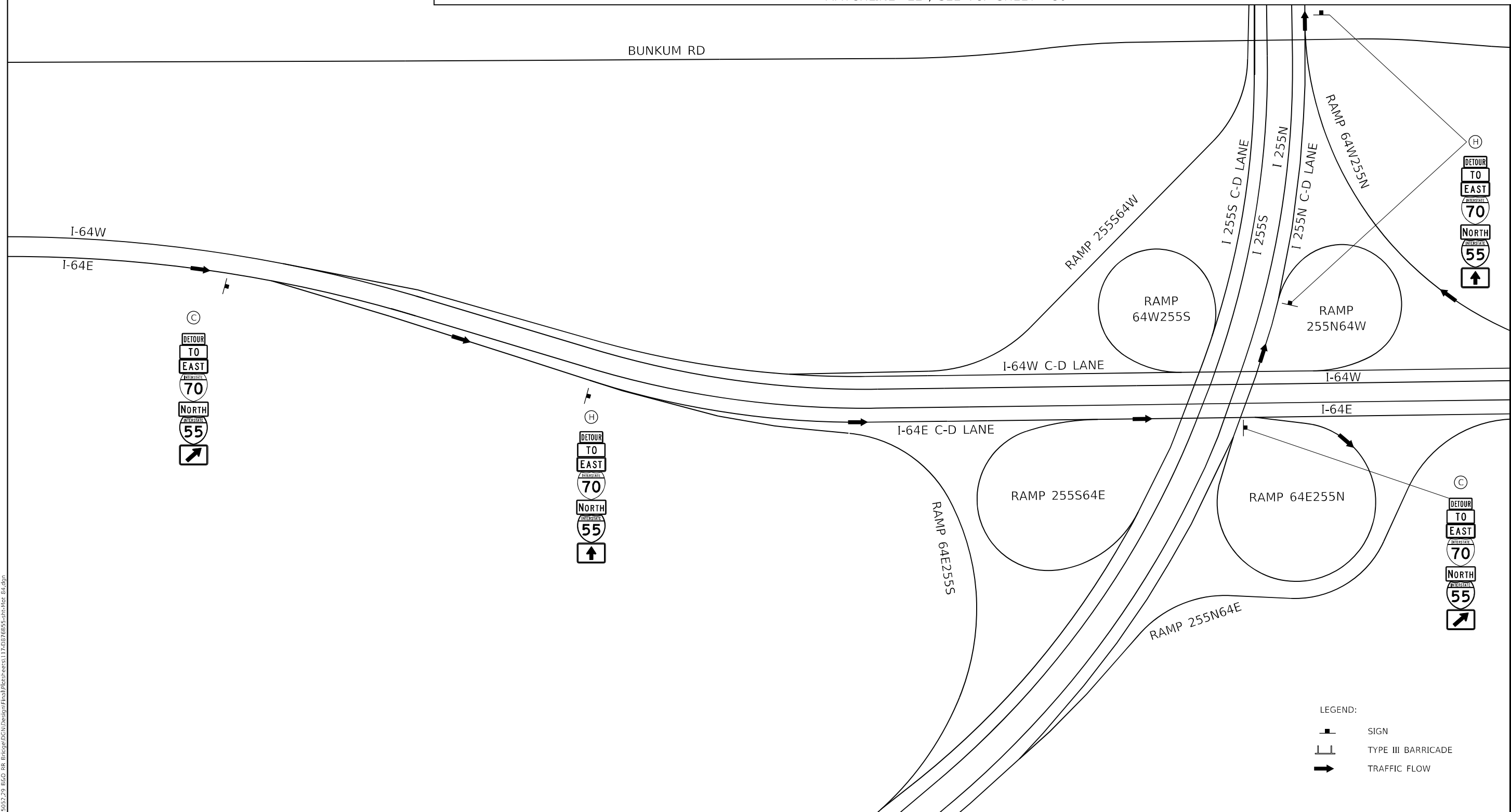

MATCHLINE "DD", SEE TCP SHEET 85

- LEGEND:
- SIGN
 - TYPE III BARRICADE
 - TRAFFIC FLOW

MODEL: D:\efk\1173052-29_B&O_BR_Bridge\DCN\Design\Final\Fetch\Sheet11730526855.dwg-Mat_B4.dgn
 FILE NAME: 2113052-29_B&O_BR_Bridge\DCN\Design\Final\Fetch\Sheet11730526855.dwg-Mat_B4.dgn

EFK Moen
Civil Engineering Design

USER NAME = zWaters	DESIGNED - SJF	REVISED -
	DRAWN - SJF	REVISED -
PLOT SCALE = 400,0000' / in.	CHECKED - SLD	REVISED -
PLOT DATE = 8/13/2024	DATE - 8/13/2024	REVISED -

STATE OF ILLINOIS
DEPARTMENT OF TRANSPORTATION

TRAFFIC CONTROL AND PROTECTION PLAN
STAGES 1 - 4A DETOUR SIGNAGE DETAIL

SCALE: 1"=200' SHEET 84 OF 5>TFC SHEETS STA. TO STA.

F.A.I. RTE.	SECTION	COUNTY	TOTAL SHEETS	SHEET NO.
70	82-5V8-R-2	ST. CLAIR	254	118
CONTRACT NO. 76K02			ILLINOIS FED. AID PROJECT	



BLACK LN

MATCHLINE "EE", SEE TCP SHEET 86
BUNKUM RD

BUNKUM RD

N 81ST ST

MATCHLINE "DD", SEE TCP SHEET 84

I-64W C-D LANE

RAMP 64W255N

I-64W
I-64E

RAMP 255N64E

I-64E C-D LANE

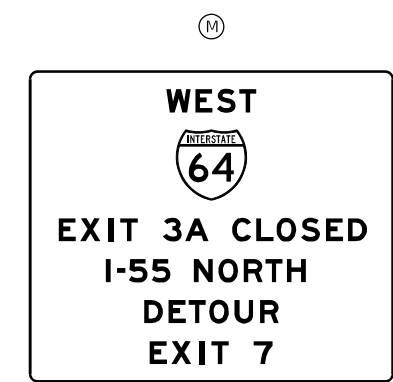

- LEGEND:
- SIGN
 - TYPE III BARRICADE
 - TRAFFIC FLOW

MODEL: D:\efk\h
FILE NAME: Z:\1305229_B&O_BR_Bridge\DCN\Design\Final\FetchSheet118_00376855.dwg-Mat_85.dgn

EFK Moen
Civil Engineering Design

USER NAME = zWaters	DESIGNED - SJF	REVISED -
	DRAWN - SJF	REVISED -
PLOT SCALE = 400,0000' / in.	CHECKED - SLD	REVISED -
PLOT DATE = 8/13/2024	DATE - 8/13/2024	REVISED -

STATE OF ILLINOIS
DEPARTMENT OF TRANSPORTATION

TRAFFIC CONTROL AND PROTECTION PLAN
STAGES 1 - 4A DETOUR SIGNAGE DETAIL

SCALE: 1"=200' SHEET 85 OF S>TFC SHEETS STA. TO STA.

F.A.I. RTE.	SECTION	COUNTY	TOTAL SHEETS	SHEET NO.
70	82-5V8-R-2	ST. CLAIR	254	119
ILLINOIS FED. AID PROJECT			CONTRACT NO. 76K02	

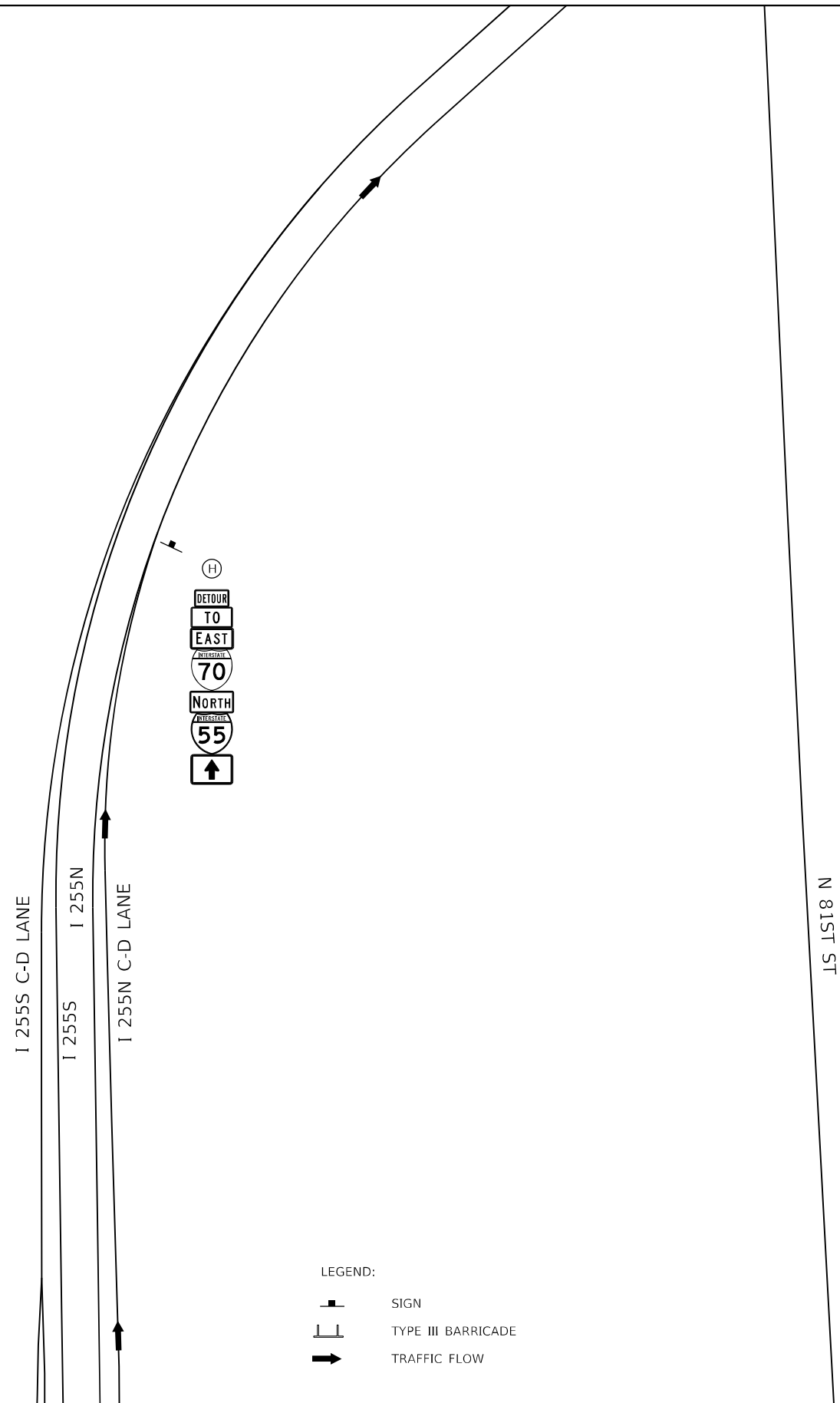

MATCHLINE "EE", SEE TCP SHEET 84 & 85

MODEL Path: \\...
 FILE NAME: Z:\13052-29 B&C RR Bridge\DCN\Design\Final\Fetch\sheet119\0376855-cht-Mat 86.dgn

EFK Moen
Civil Engineering Design

USER NAME = zWaters	DESIGNED - SJF	REVISED -
	DRAWN - SJF	REVISED -
PLOT SCALE = 400,0000' / in.	CHECKED - SLD	REVISED -
PLOT DATE = 8/13/2024	DATE - 8/13/2024	REVISED -



**STATE OF ILLINOIS
DEPARTMENT OF TRANSPORTATION**

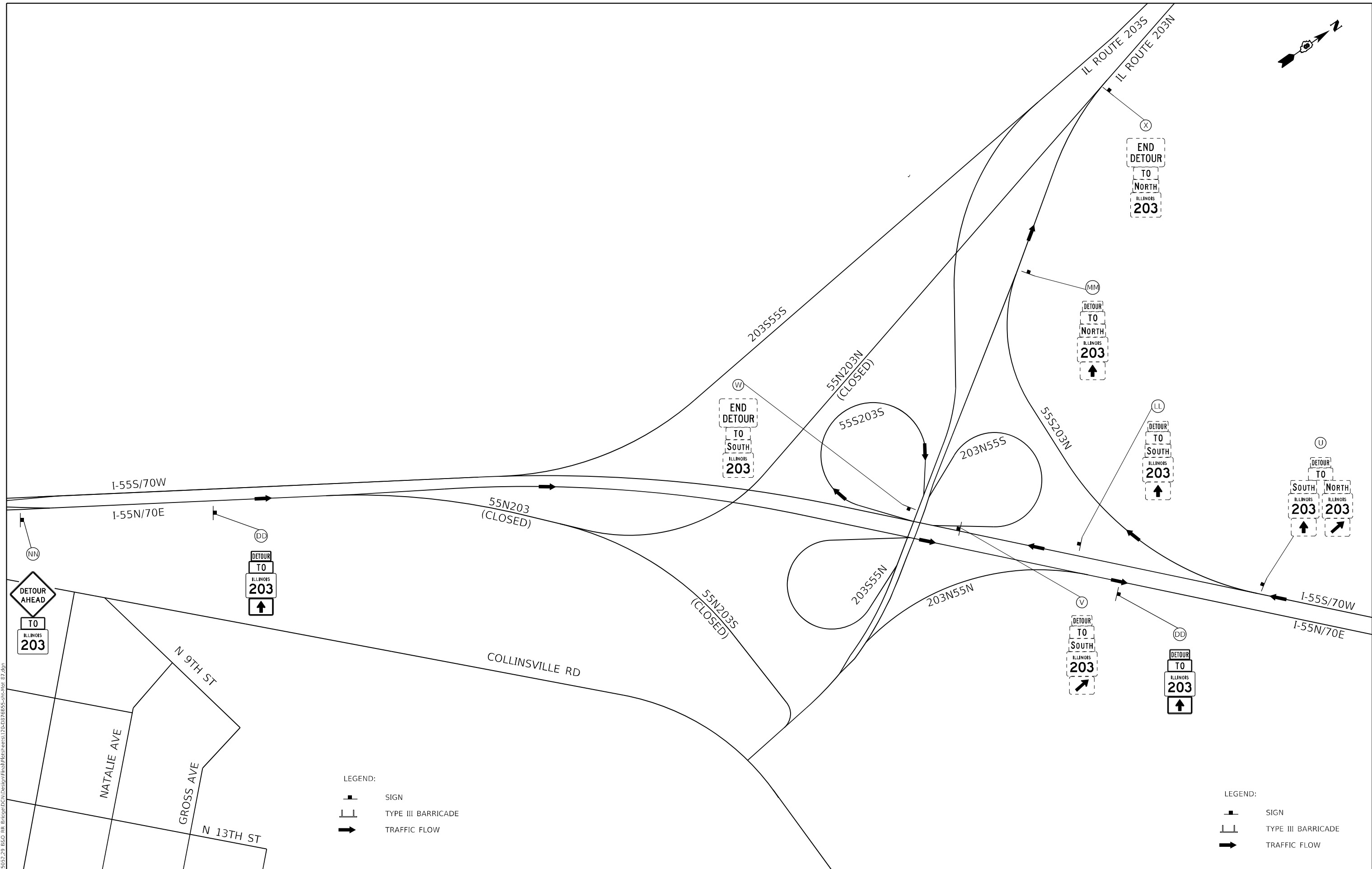
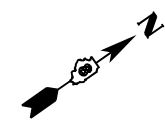

**TRAFFIC CONTROL AND PROTECTION PLAN
STAGES 1 - 4A DETOUR SIGNAGE DETAIL**

SCALE: 1"=200' SHEET 86 OF 5>TFC SHEETS STA. TO STA.

F.A.I. RTE.	SECTION	COUNTY	TOTAL SHEETS	SHEET NO.
70	82-5V8-R-2	ST. CLAIR	254	120
ILLINOIS FED. AID PROJECT			CONTRACT NO. 76K02	



LEGEND:
 SIGN
 TYPE III BARRICADE
 TRAFFIC FLOW

LEGEND:
 SIGN
 TYPE III BARRICADE
 TRAFFIC FLOW

MODEL: D:\efk\...
 FILE NAME: 241305229_B60_BR_Bridge\DC\Design\Final\Fetch\Sheet17040376655.dwg, Mod: 8/7/24

EFK Moen
 Civil Engineering Design

USER NAME = zWaters	DESIGNED - SJF	REVISED -
PLOT SCALE = 400,0000' / in.	DRAWN - SJF	REVISED -
PLOT DATE = 8/13/2024	CHECKED - SLD	REVISED -
	DATE - 8/13/2024	REVISED -



**STATE OF ILLINOIS
 DEPARTMENT OF TRANSPORTATION**

**TRAFFIC CONTROL AND PROTECTION PLAN
 STAGE 4A DETOUR SIGNAGE DETAIL**

SCALE: 1"=200' SHEET 87 OF 5>TFC SHEETS STA. TO STA.

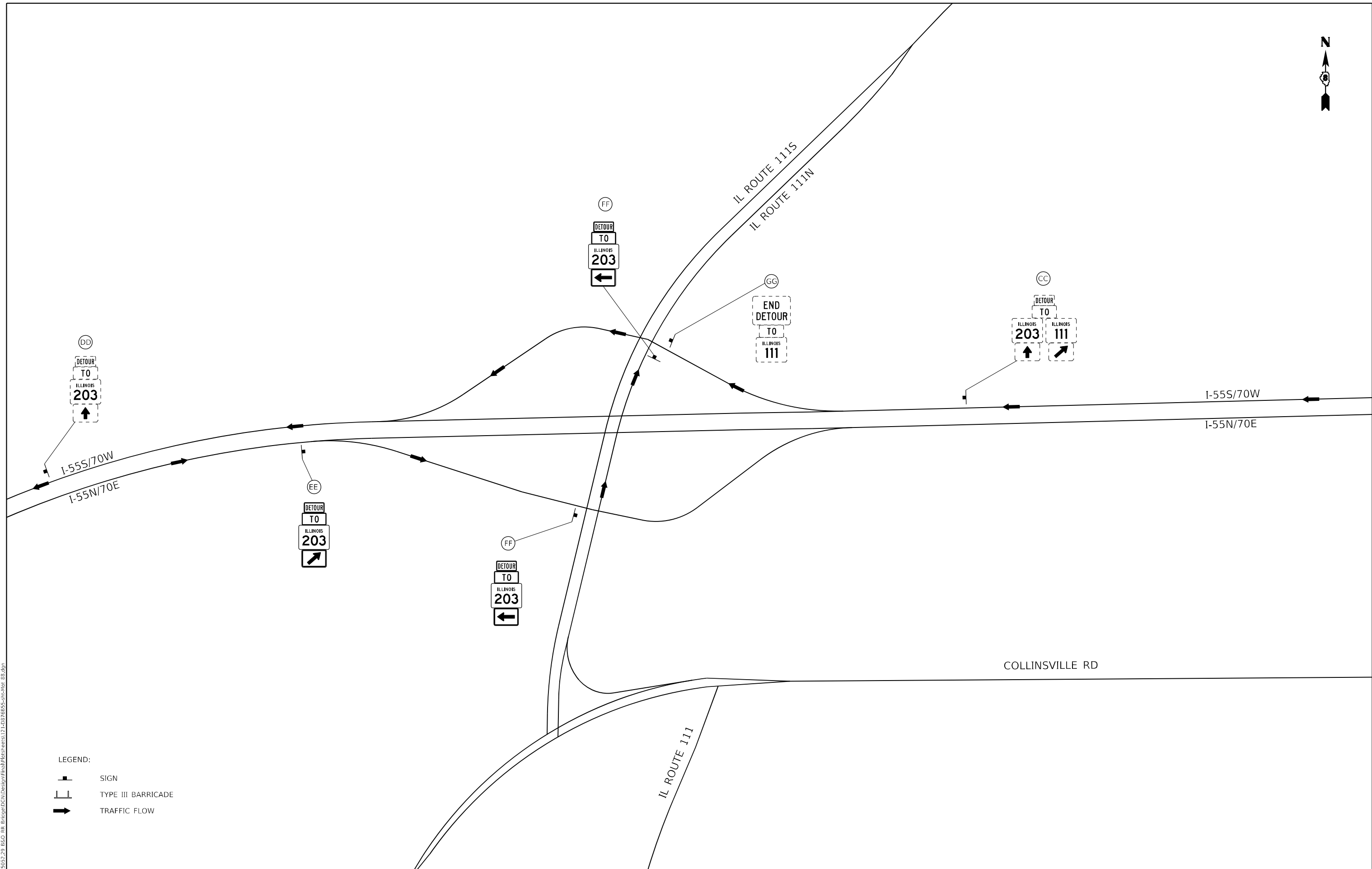
F.A.I. RTE.	SECTION	COUNTY	TOTAL SHEETS	SHEET NO.
70	82-5V8-R-2	ST. CLAIR	254	121
CONTRACT NO. 76K02				
ILLINOIS FED. AID PROJECT				



- LEGEND:
-  SIGN
 -  TYPE III BARRICADE
 -  TRAFFIC FLOW

MODEL: D:\efk\h...
 FILE NAME: 2413052.29_B&O_BR_Bridge\DCN\Design\Final\Fiber\Sheet17-10376855.dwg-Mat_88.dgn

EFK Moen
Civil Engineering Design

USER NAME = zWaters	DESIGNED - SJF	REVISED -
	DRAWN - SJF	REVISED -
PLOT SCALE = 400,0000' / in.	CHECKED - SLD	REVISED -
PLOT DATE = 8/13/2024	DATE - 8/13/2024	REVISED -



**STATE OF ILLINOIS
DEPARTMENT OF TRANSPORTATION**

**TRAFFIC CONTROL AND PROTECTION PLAN
STAGE 4A DETOUR SIGNAGE DETAIL**

SCALE: 1"=200' SHEET 88 OF 82 TFC SHEETS STA. TO STA.

F.A.I. RTE.	SECTION	COUNTY	TOTAL SHEETS	SHEET NO.
70	82-5V8-R-2	ST. CLAIR	254	122
CONTRACT NO. 76K02				
ILLINOIS FED. AID PROJECT				

LEGEND:

-  SIGN
-  TYPE III BARRICADE
-  TRAFFIC FLOW

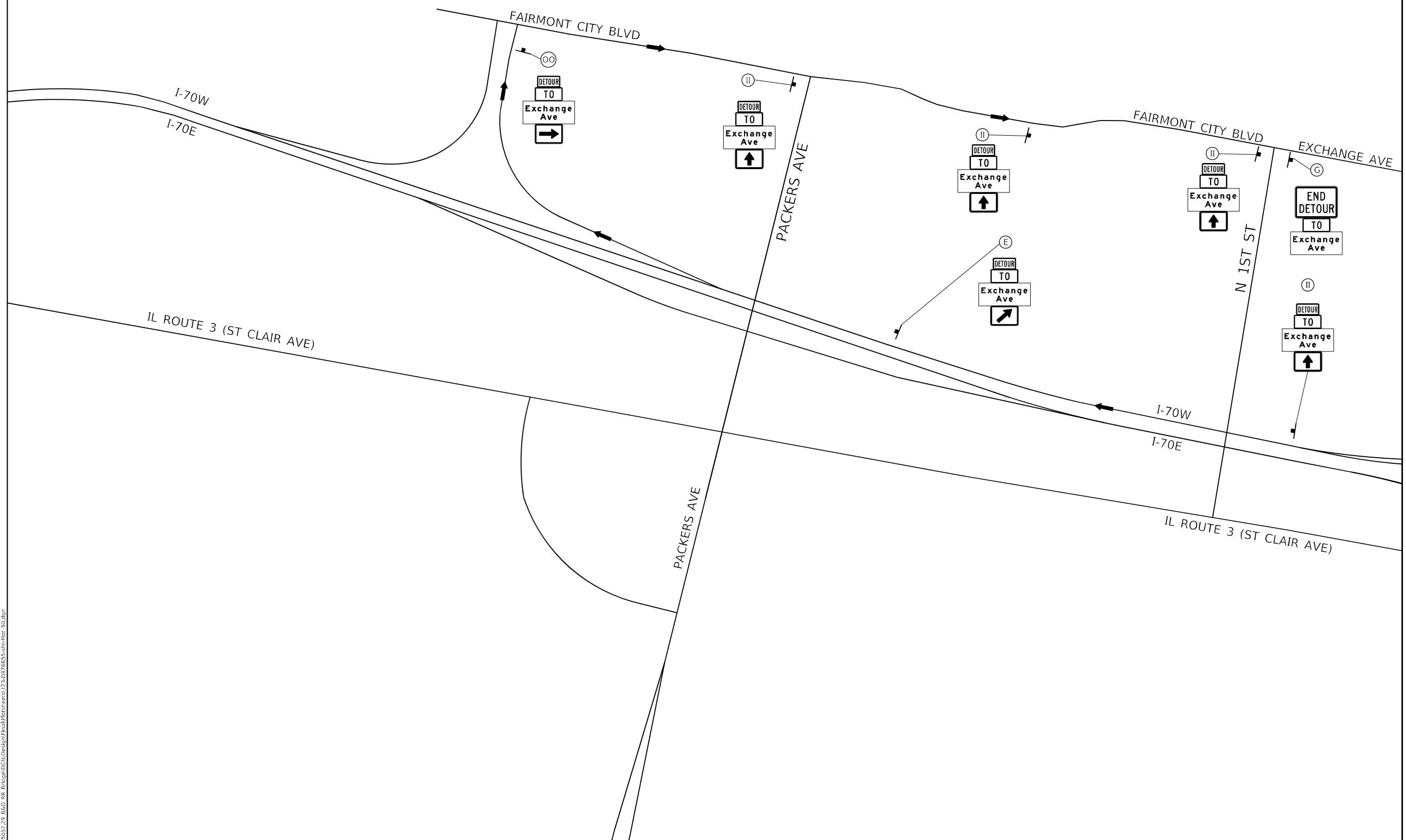

MATCHLINE "BB", SEE TCP SHEET 91

MODEL: D:\efh\...
FILE NAME: 2413052.29_B&O_BR_Bridge\DCN\Design\Final\FetchSheet173-00376855.dwg-Mat_90.dgn

EFK Moen
Civil Engineering Design

USER NAME = zWaters	DESIGNED - SJF	REVISED -
DRAWN - SLD	REVISED -	
PLOT SCALE = 400,0000' / in.	CHECKED - SLD	REVISED -
PLOT DATE = 8/13/2024	DATE - 8/13/2024	REVISED -

**STATE OF ILLINOIS
DEPARTMENT OF TRANSPORTATION**



**TRAFFIC CONTROL AND PROTECTION PLAN
STAGES 6 & 7 DETOUR SIGNAGE DETAIL**

SCALE: 1"=200' SHEET 90 OF 5>TFC SHEETS STA. TO STA.

F.A.I. RTE.	SECTION	COUNTY	TOTAL SHEETS	SHEET NO.
70	82-5V8-R-2	ST. CLAIR	254	124
CONTRACT NO. 76K02				
ILLINOIS FED. AID PROJECT				

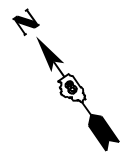
MATCHLINE "CC", SEE TCP SHEET 92



- LEGEND:
-  SIGN
 -  TYPE III BARRICADE
 -  TRAFFIC FLOW

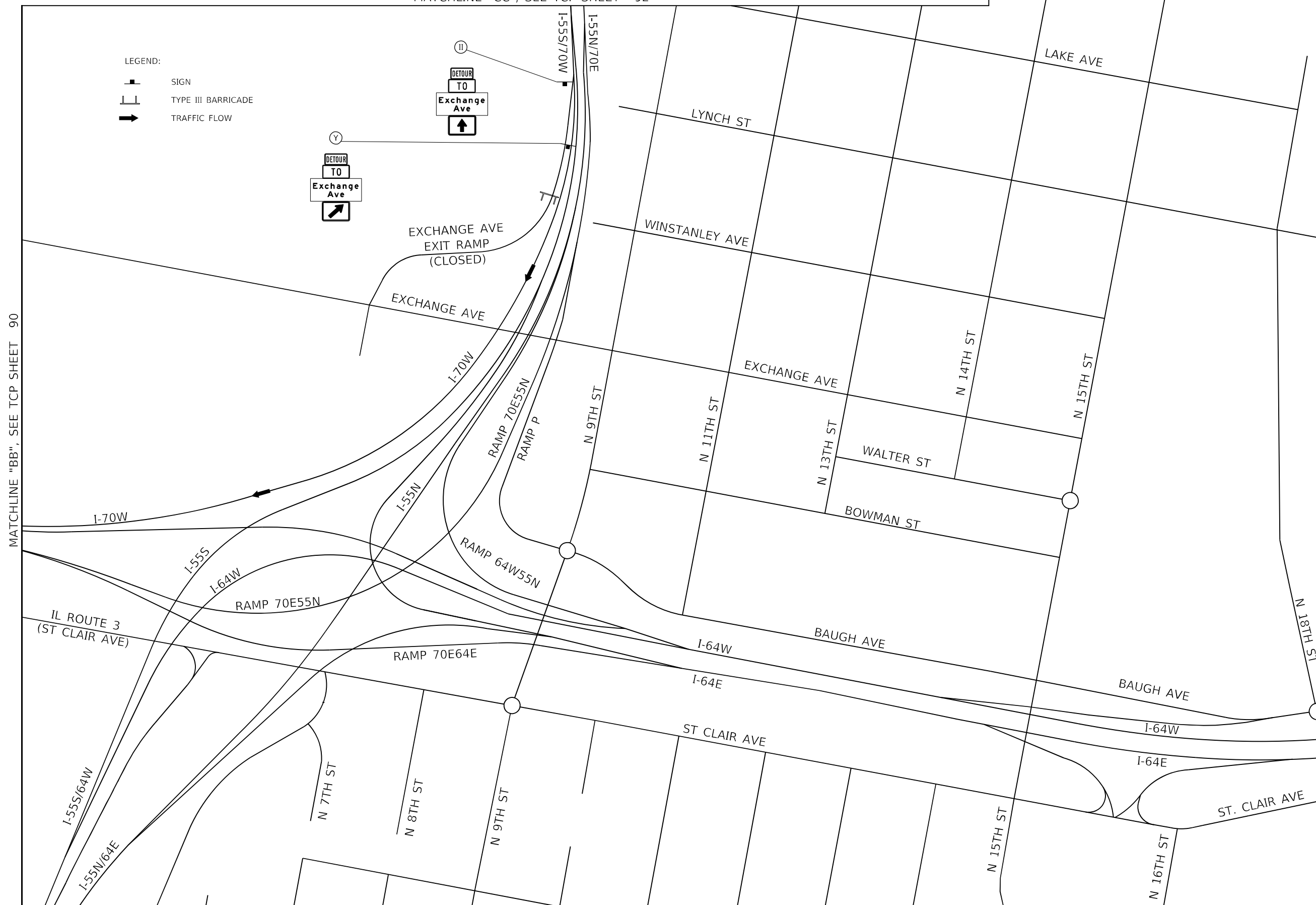

MATCHLINE "BB", SEE TCP SHEET 90

MODEL: D:\efk\...
FILE NAME: 201303239_B60_BR_Bridge\DCN\Design\Final\FB\Sheet17.dwg
DATE: 8/13/2024

EFK Moen
Civil Engineering Design

USER NAME = zWaters	DESIGNED - SJF	REVISED -
	DRAWN - SJF	REVISED -
PLOT SCALE = 400,000' / in.	CHECKED - SLD	REVISED -
PLOT DATE = 8/13/2024	DATE - 8/13/2024	REVISED -



**STATE OF ILLINOIS
DEPARTMENT OF TRANSPORTATION**

**TRAFFIC CONTROL AND PROTECTION PLAN
STAGES 6 & 7 DETOUR SIGNAGE DETAIL**

SCALE: 1"=200' SHEET 91 OF 5>TFC SHEETS STA. TO STA.

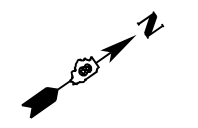
F.A.I. RTE.	SECTION	COUNTY	TOTAL SHEETS	SHEET NO.
70	82-5V8-R-2	ST. CLAIR	254	125
CONTRACT NO. 76K02				
ILLINOIS FED. AID PROJECT				



- LEGEND:
-  SIGN
 -  TYPE III BARRICADE
 -  TRAFFIC FLOW

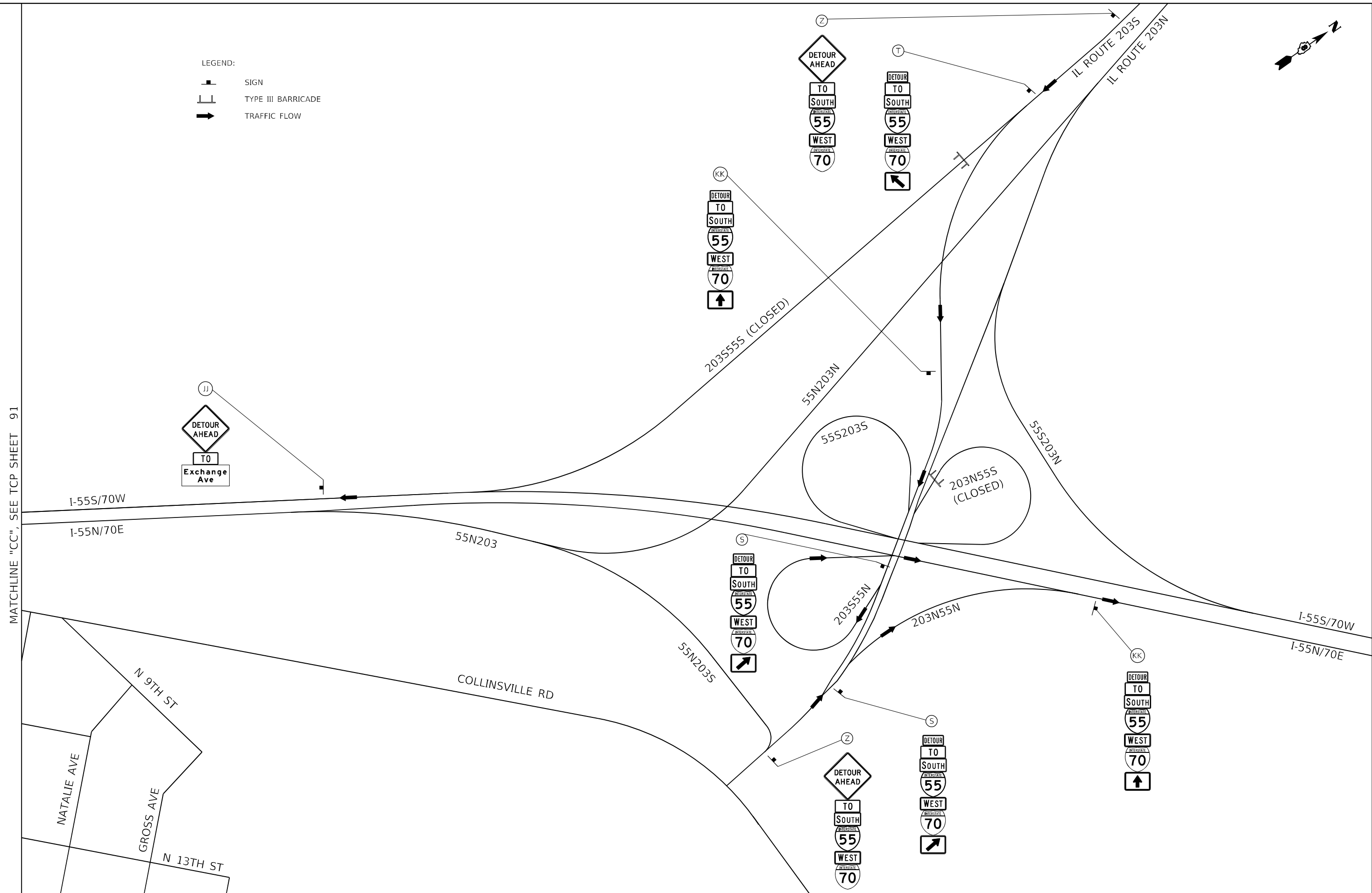

MATCHLINE "CC", SEE TCP SHEET 91

MODEL: D:\efk\175-00376855-001-001.dgn
FILE NAME: 20240813_175-00376855-001-001.dgn

EFK Moen
Civil Engineering Design

USER NAME = zWaters	DESIGNED - SJF	REVISED -
PLOT SCALE = 400,000' / in.	DRAWN - SJF	REVISED -
PLOT DATE = 8/13/2024	CHECKED - SLD	REVISED -
	DATE - 8/13/2024	REVISED -



**STATE OF ILLINOIS
DEPARTMENT OF TRANSPORTATION**

**TRAFFIC CONTROL AND PROTECTION PLAN
STAGES 6 & 7 DETOUR SIGNAGE DETAIL**

SCALE: 1"=200' SHEET 92 OF 5>TFC SHEETS STA. TO STA.

F.A.I. RTE.	SECTION	COUNTY	TOTAL SHEETS	SHEET NO.
70	82-5V8-R-2	ST. CLAIR	254	126
CONTRACT NO. 76K02				
ILLINOIS FED. AID PROJECT				

LEGEND:

-  SIGN
-  TYPE III BARRICADE
-  TRAFFIC FLOW

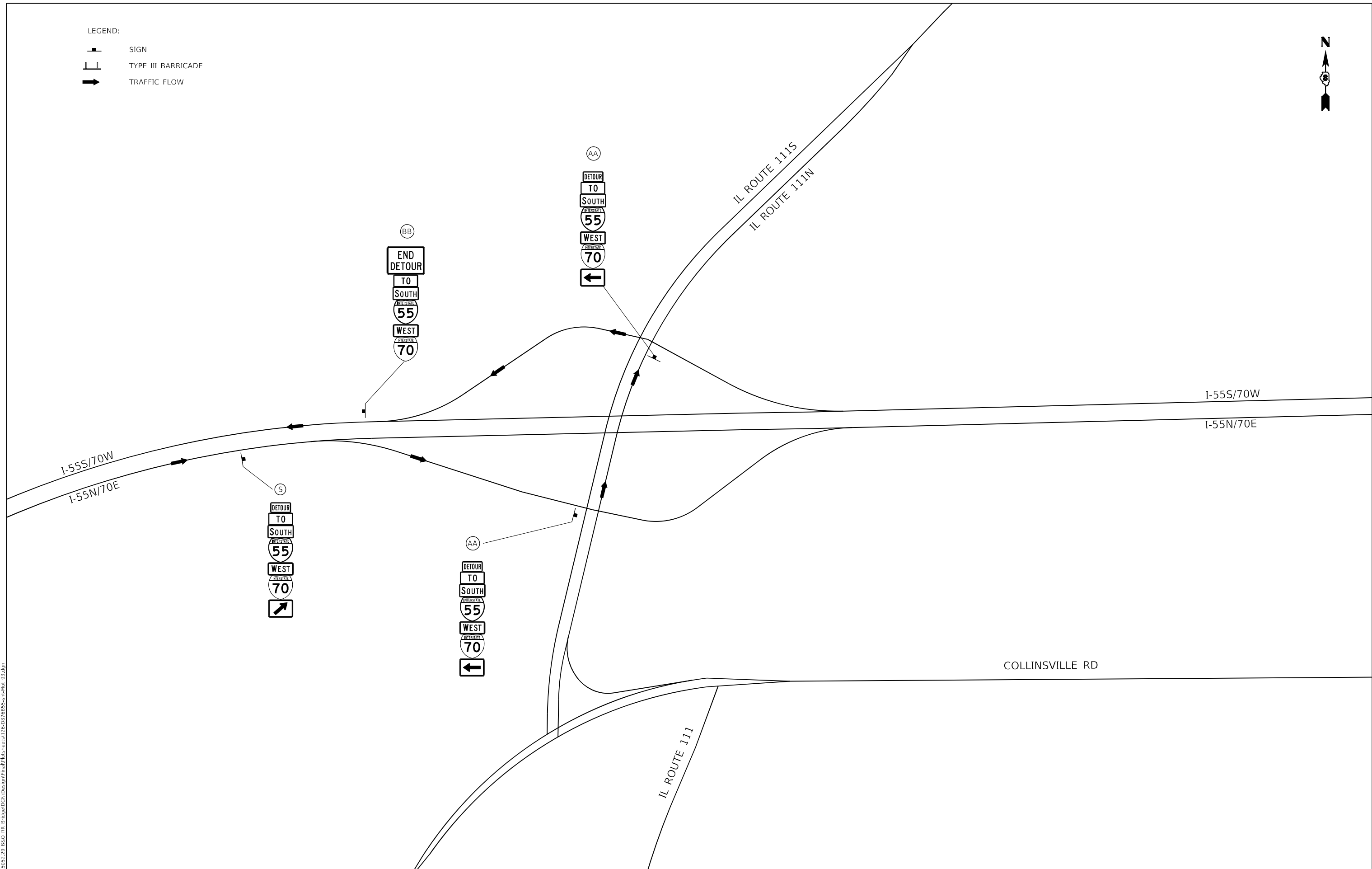

MODEL: D:\efk\h
 FILE NAME: Z:\13052.29 B&O BR Bridge\DCN\Design\Final\Fetch\Sheet176-0376855.dwg-Mbr 93.dgn

EFK Moen
Civil Engineering Design

USER NAME = zWaters	DESIGNED - SJF	REVISED -
	DRAWN - SJF	REVISED -
PLOT SCALE = 400,0000' / in.	CHECKED - SLD	REVISED -
PLOT DATE = 8/13/2024	DATE - 8/13/2024	REVISED -

DESIGNED - SJF	REVISED -
DRAWN - SJF	REVISED -
CHECKED - SLD	REVISED -
DATE - 8/13/2024	REVISED -

**STATE OF ILLINOIS
DEPARTMENT OF TRANSPORTATION**

**TRAFFIC CONTROL AND PROTECTION PLAN
STAGES 6 & 7 DETOUR SIGNAGE DETAIL**

F.A.I. RTE.	SECTION	COUNTY	TOTAL SHEETS	SHEET NO.
70	82-5V8-R-2	ST. CLAIR	254	127
CONTRACT NO. 76K02				
ILLINOIS FED. AID PROJECT				

SCALE: 1"=200' SHEET 93 OF 5>TFC SHEETS STA. TO STA.

STATE OF ILLINOIS
 DEPARTMENT OF TRANSPORTATION
 OFFICE OF HIGHWAYS PROJECT IMPLEMENTATION

SPACE RESERVED FOR RECORDING OFFICER

SHEET INDEX		
SHEET NO.	STATION TO STATION	DESCRIPTION
1	N/A	COVER
2	N/A	LEGEND AND NOTES
3	N/A	OVERALL PARCEL LAYOUT
4	N/A	PLAT OF HIGHWAY
5	N/A	PLAT OF HIGHWAY
6	N/A	PLAT OF HIGHWAY
7	N/A	PLAT OF HIGHWAY
8	N/A	PLAT OF HIGHWAY
9	N/A	PLAT OF HIGHWAY
10	N/A	COORDINATE TABLES
11	N/A	TOTAL HOLDING SKETCHES

PLAT OF HIGHWAY

FAI ROUTE 70 (I-55/70)
 SECTION 82-5VB-R-2
 ST. CLAIR COUNTY
 JOB NO. R-98-011-20

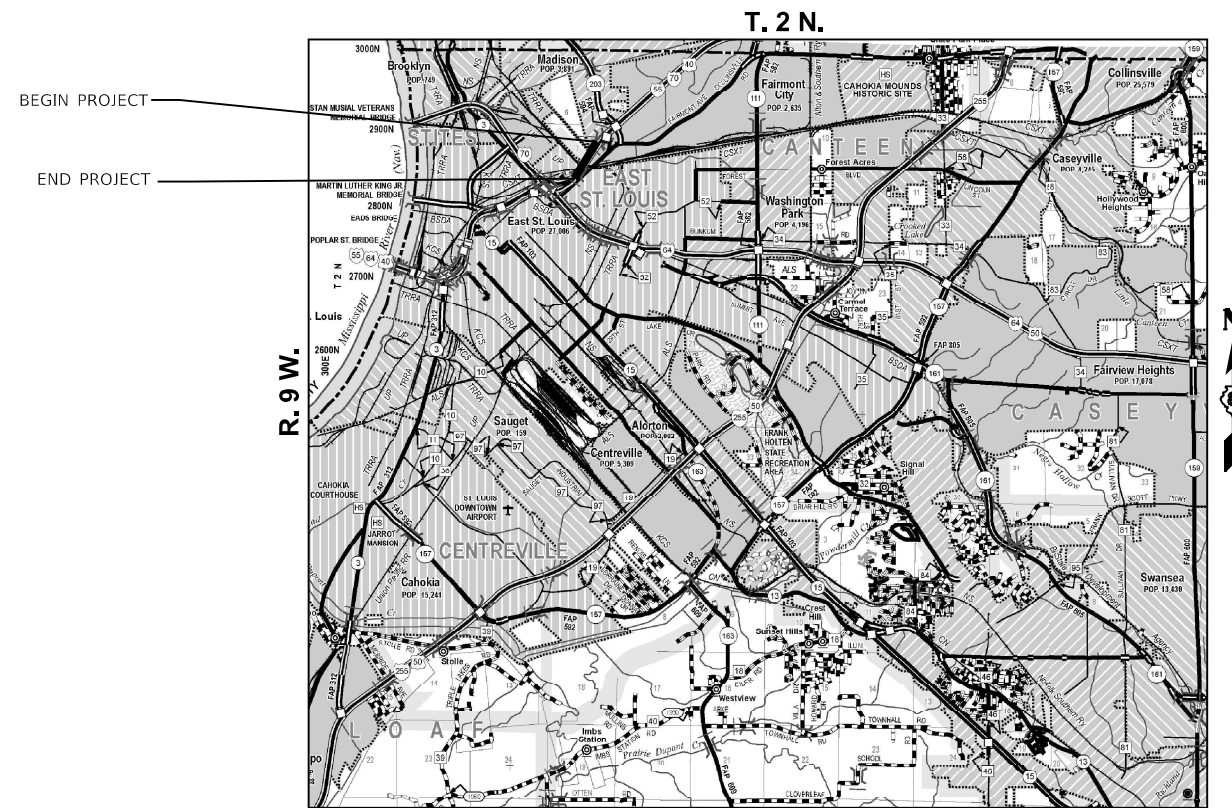

PROJECT LENGTH = xxx LIN. FT. = x.xxx MILE

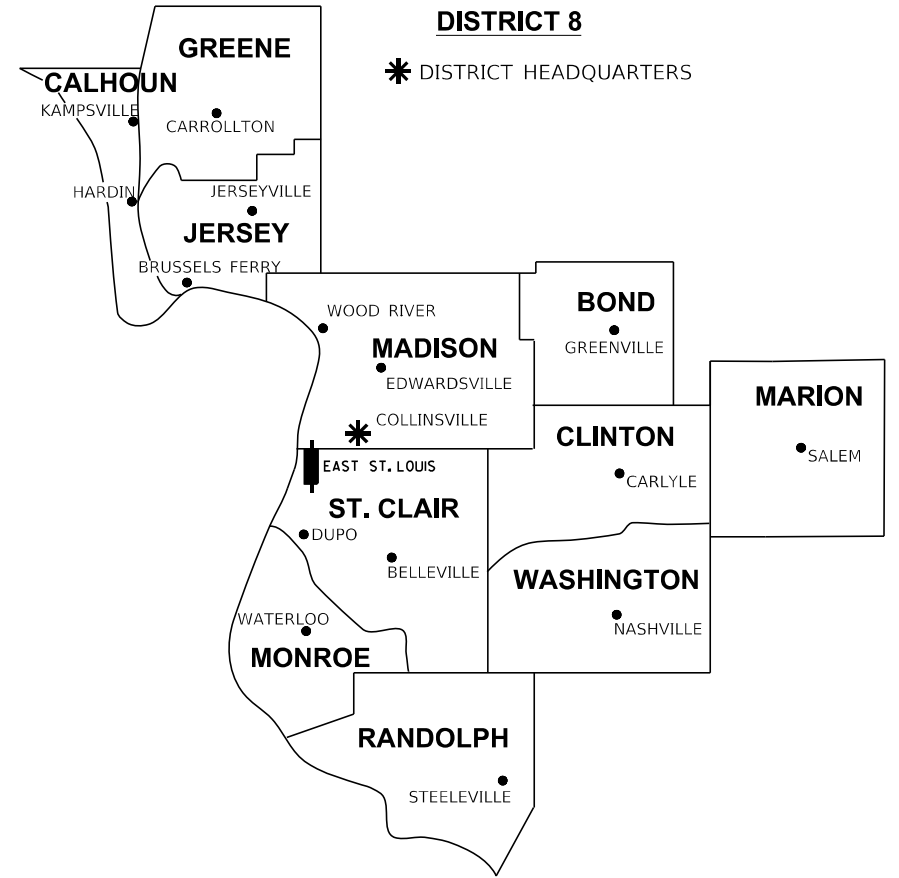

LOCATION OF SECTION INDICATED THUS: [thick black line symbol]

PREPARED BY:



GREGORY S. McVICAR, PLS NO. 3512
 LICENSE EXPIRATION DATE: 11/30/2024

SHEET 1 OF 11

ILLINOIS DEPARTMENT OF TRANSPORTATION OFFICE OF HIGHWAYS PROJECT IMPLEMENTATION/REGION 5/DISTRICT 8 1102 EASTPORT PLAZA DRIVE COLLINSVILLE, ILLINOIS 62234-6198				
F.A.I. RTE.	SECTION	COUNTY	TOTAL SHEETS	SHEET NO.
70	82-5VB-R-2	ST. CLAIR	254	128
			CONTRACT NO. 76K02	
FED. ROAD DIST. NO.	ILLINOIS	FED. AID PROJECT		

LEGEND FOR EXISTING TOPOGRAPHIC SYMBOLS

TRAFFIC SIGNAL GULFBOX	○	DRAINAGE FLOW LINE	FL
TRAFFIC SIGNAL HANDHOLE	⊞	RIP RAP	⊞
TRAFFIC SIGNAL SIGNAL POST	○	HEADWALL	⊞
TRAFFIC SIGNAL STEEL MAST ARM	⊞	CULVERT END SECTION	⊞
TRAFFIC SIGNAL PEDESTRIAN PUSH BUTTON	●	DRAINAGE MANHOLE	○
TRAFFIC SIGNAL WOODEN POLE	○	INLET	○
TRAFFIC SIGNAL VEHICLE DETECTION PRIORITY	⊞	ROADWAY DITCH FLOW	⊞
TRAFFIC SIGNAL VEHICLE DETECTION MAGNET	⊞	VEGETATION LINE	⊞
TRAFFIC SIGNAL JUNCTION BOX	⊞	STUMP	⊞
TRAFFIC SIGNAL CONTROLLER	⊞	SHRUB	⊞
TRAFFIC SIGNAL HEAVY DUTY HANDHOLE	⊞	EVERGREEN TREE	⊞
RAILROAD CANTILEVER MAST ARM	⊞	DECIDUOUS TREE	⊞
RAILROAD CROSSBUCK	⊞	WOODS/BUSH LINE	⊞
RAILROAD TRACK	⊞	TRAFFIC SIGN	⊞
RAILROAD TRACK (ABANDONED)	⊞	GUARDRAIL POST	⊞
RAILROAD CROSSGATE	⊞	GUARDRAIL	⊞
RAILROAD CONTROL BOX	⊞	FIELD LINE	⊞
RAILROAD FLASHING SIGNAL	⊞	LEVEE/NOISE BARRIER	⊞
UTILITY TELEPHONE SPLICE BOX	⊞	FENCE	⊞
UTILITY POWER POLE	⊞	MAIL BOX	⊞
UTILITY TRAFFIC SIGNAL	⊞	ADVERTISING SIGN	⊞
UTILITY LIGHT POLE	⊞	MARSH	⊞
UTILITY FIRE HYDRANT	⊞	LIGHTING HANDHOLE	⊞
UTILITY MANHOLE	⊞	LIGHTING POWER POLE	⊞
UTILITY TELEPHONE POLE	⊞	LIGHTING JUNCTION BOX	⊞
UTILITY GUY ANCHOR	⊞	LIGHTING HEAVYDUTY HANDHOLE	⊞
UTILITY PIPELINE WARNING SIGN	⊞	LIGHTING PIPELINE CONTROLLER	⊞
UTILITY HANDHOLE	⊞	LIGHTING PULL POINT	⊞
UTILITY SPLICE BOX	⊞	HIGHWAY LIGHTING ELECTRICAL GROUND	⊞
UTILITY JUNCTION BOX	⊞	HIGHWAY LIGHTING SINGLE UNIT	⊞
UTILITY HEAVY DUTY HANDHOLE	⊞	HIGHWAY LIGHTING DOUBLE UNIT	⊞
UTILITY DOUBLE HANDHOLE	⊞	EXISTING CONCRETE BARRIER	⊞
UTILITY CONTROLLER	⊞	EXISTING CREEK OR DITCH	⊞
UTILITY WATER METER	⊞	EXISTING EDGE OF PAVEMENT	⊞

RIGHT-OF-WAY LEGEND

	QUARTER SECTION CORNERS
	SECTION CORNERS
	EXISTING CENTERLINE
	EXISTING RIGHT-OF-WAY LINE
	FORMER RIGHT-OF-WAY LINE
	EXISTING IDOT EASEMENT LINE
	EXISTING EASEMENT LINE
	BUILDING SETBACK LINE
	EXISTING ACCESS CONTROL LINE
	EXISTING RIGHT-OF-WAY & PROPOSED ACCESS CONTROL LINE
	PROPOSED ACCESS CONTROL LINE
	PROPOSED CENTERLINE
	PROPOSED RIGHT-OF-WAY LINE
	PROPOSED TEMPORARY EASEMENT LINE
	PROPOSED PERMANENT EASEMENT LINE
	SECTION LINE
	QUARTER SECTION LINE
	QUARTER QUARTER SECTION LINE
	PROPERTY LINE (TITLE)
	RECORDED PLAT/DEED LINE
	APPARENT PROPERTY LINE
	SAME OWNERSHIP
	121.45' MEASURED DIMENSION
	(121.45') RECORDED DIMENSION
	FOUND STONE
	FOUND IRON PIPE OR IRON ROD AT CORNER UNLESS OTHERWISE NOTED
	SET 5/8 INCH IRON ROD WITH PLASTIC CAP IDENTIFIED BY SURVEYORS LICENSE NUMBER AT CORNER UNLESS OTHERWISE NOTED
	PERMANENT SURVEY MONUMENT, I.D.O.T. STD. 667101 (TO BE SET BY OTHERS)
	FOUND REBAR WITH ALUMINUM CAP AS SURVEY CONTROL UNLESS OTHERWISE NOTED
	FOUND CUT CROSS
	SET CUT CROSS

- STAKING OF PROPOSED RIGHT-OF-WAY AND PERMANENT EASEMENT CORNERS. SET 5/8 INCH METAL ROD WITH DIVISION OF HIGHWAY SURVEY ALUMINUM CAP TO MONUMENT THE POSITION SHOWN, IDENTIFIED BY INSCRIPTION DATA AND SURVEYORS LICENSE NUMBER.
- STAKING OF PROPOSED RIGHT-OF-WAY AND PERMANENT EASEMENT CORNERS IN CULTIVATED AREA, A MINIMUM OF 20 INCHES BELOW THE GROUND SURFACE, SET 5/8 INCH METAL ROD WITH DIVISION OF HIGHWAY SURVEY ALUMINUM CAP TO MONUMENT THE POSITION SHOWN, IDENTIFIED BY INSCRIPTION DATA AND SURVEYORS LICENSE NUMBER.

LEGEND FOR ABBREVIATIONS

A/C	ACCESS CONTROL
AC	ACRE
AVE	AVENUE
BK	BOOK
BLVD	BOULEVARD
CL	CENTERLINE
CAB	CABINET
CH	COUNTY HIGHWAY
Ch	CHAIN
CP	CONTROL POINT
CPS	COTTON PICKER SPINDLE
DB	DEED BOOK
E	EAST
EX	EXISTING
FA	FEDERAL AID
FAI	FEDERAL AID INTERSTATE
FAP	FEDERAL AID PRIMARY
FAS	FEDERAL AID SECONDARY
FAU	FEDERAL AID URBAN
FND	FOUND
ha	HECTARE
IP	IRON PIPE
IR	IRON ROD
LT	LEFT
m ²	METER
m	SQUARE METERS
N	NORTH
N/F	NOW OR FORMERLY
N & BC	NAIL AND BOTTLE CAP
N & C	NAIL AND CAP
N & W	NAIL AND WASHER
NE	NORTHEAST
NW	NORTHWEST
PB	PLAT BOOK
PG	PAGE
POB	POINT OF BEGINNING
POC	POINT OF COMMENCEMENT
POT	POINT ON TANGENT
PL	PROPERTY LINE
PR	PROPOSED
R	RANGE
RD	ROAD
REC	RECORD
ROW	RIGHT-OF-WAY
RR	RAILROAD
RRS	RAILROAD SPIKE
RT	RIGHT
RTE	ROUTE
S	SOUTH
SBI	STATE BOND ISSUE
SE	SOUTHEAST
SEC	SECTION
SQ FT	SQUARE FEET
SR	STATE ROUTE
ST	STREET
STA	STATION
SMK	SURVEY MARKER
SW	SOUTHWEST
T	TOWNSHIP
TR	TOWNSHIP ROAD
USGS	U.S. GEOLOGICAL SURVEY
W	WEST

SPACE RESERVED FOR RECORDING OFFICER

PROPOSED PARCEL NUMBER LEGEND

8001001	PROPOSED FEE SIMPLE ACQUISITION
8001001PE	PROPOSED PERMANENT EASEMENT
8001001TE	PROPOSED TEMPORARY EASEMENT
8001001DED	PROPOSED DEDICATION
8001001AC	PROPOSED ACCESS CONTROL LINE

CURVE ABBREVIATIONS

PC	POINT OF CURVATURE
PI	POINT OF INTERSECTION
PT	POINT OF TANGENCY
PRC	POINT OF REVERSE CURVE
PCC	POINT OF COMPOUND CURVE
R	RADIUS OF CURVE
L	LENGTH OF CURVE
CB	CHORD BEARING
C	CHORD LENGTH
D	DEGREE OF CURVE
E	EXTERNAL ORDINATE
Δ	CENTRAL ANGLE

BASIS OF COORDINATE & BEARING STATEMENT

BASIS OF BEARINGS AND COORDINATES: ALL DISTANCES AND BEARINGS SHOWN HEREON ARE GRID VALUES BASED ON THE FOLLOWING PROJECTION DEFINITION. THE PROJECTION WAS DEFINED SUCH THAT THE GRID DISTANCE ARE EQUIVALENT TO "GROUND" DISTANCE.

PROJECTION PARAMETERS

PROJECTION: LAMBERT CONFORMAL CONIC (SINGLE PARALLEL)
 LATITUDE OF ORIGIN: 38°12'00" N
 CENTRAL MERIDIAN: 89°50'00" W
 CM SCALE FACTOR: 1.000015304
 FALSE NORTHING: 0 SFT
 FALSE EASTING: 129,000 SFT

THE SURVEY WAS REFERENCED TO THE NATIONAL SPATIAL REFERENCE SYSTEM BY DIRECT CONNECTION TO THE FOLLOWING MONUMENTS.

PID#: JC0158/Z 248
 LATITUDE: N38°37'23.33694" NORTHING: 154210.8642 SFT
 LONGITUDE: W90°05'27.38555" EASTING: 55398.3550 SFT
 ELIPSOIDAL HT.: 318.7362 SFT ORTHO HT.: 420.3528 SFT (GEOID 12B)

PID#: MRC14
 LATITUDE: N38°38'32.05672" NORTHING: 161197.8848 SFT
 LONGITUDE: W90°07'52.05391" EASTING: 43939.3370 SFT
 ELIPSOIDAL HT.: 322.6175 SFT ORTHO HT.: 424.5119 SFT (GEOID 12B)

**PROJECT SURVEY CONTROL DATA
GROUND SURFACE COORDINATE SYSTEM**

POINT NO.	NORTH (FEET)	EAST (FEET)	DESCRIPTION
200	160,368.7067	54,749.3975	IRON PIN W/PLASTIC CAP
6001	154,401.0726	49,926.5982	IRON PIN W/ALUMINUM CAP
P001	159,242.3449	59,274.1786	IRON PIN W/ALUMINUM CAP
SC08	166,841.1764	55,087.1273	IRON PIN W/ALUMINUM CAP
SC17	167,162.9355	61,790.3088	IRON PIN W/ALUMINUM CAP
SC18	161,440.2268	51,656.9839	IRON PIN W/ALUMINUM CAP
MRC14	161,197.8850	43,939.3370	IRON PIN W/ALUMINUM CAP
140	158,683.0310	40,918.7360	IRON PIN W/ALUMINUM CAP

TOTAL HOLDING AREA SOURCE TABLE

1	AREA ACCORDING TO THE SURVEY PERFORMED BY THE CONSULTANT.
2	AREA LISTED IN RECORDED DEED.
3	AREA ACCORDING TO A RECORDED SUBDIVISION PLAT.
4	AREA ACCORDING TO A PLAT OF SURVEY.
5	AREA CALCULATED FROM RECORDED DEEDS OR TITLE COMMITMENTS - NOT SURVEYED.
6	AREA ACCORDING TO COUNTY TAX MAPS AND COUNTY ASSESSMENT RECORDS.
7	AREA ACCORDING TO OTHER RECORDS, SEE NOTE ON THE PLAT OF HIGHWAYS.

TOPOGRAPHIC STATEMENT

THE TOPOGRAPHY SHOWN HEREON WAS PHYSICALLY LOCATED IN THE FIELD BY THE SURVEYOR ON 03/25/2020.

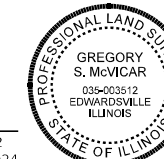

GREGORY S. McVICAR, PLS NO. 3512
 LICENSE EXPIRATION DATE: 11/30/2024



ILLINOIS DEPARTMENT OF TRANSPORTATION
PLAT OF HIGHWAY
 FAI ROUTE 70 (I-55/70)
 SECTION 82-5VB-R-2
 ST. CLAIR COUNTY
 JOB NO. R-98-011-20
 LEGEND AND NOTES

SHEET 2 OF 11

ILLINOIS DEPARTMENT OF TRANSPORTATION OFFICE OF HIGHWAYS PROJECT IMPLEMENTATION/REGION 5/DISTRICT 8 1102 EASTPORT PLAZA DRIVE COLLINSVILLE, ILLINOIS 62234-6198			
F.A.I. RTE.	SECTION	COUNTY	TOTAL SHEETS
70	82-5VB-R-2	ST. CLAIR	254
CONTRACT NO. 76K02			SHEET NO. 129
FED. ROAD DIST. NO. _	ILLINOIS	FED. AID PROJECT	



SPACE RESERVED FOR RECORDING OFFICER

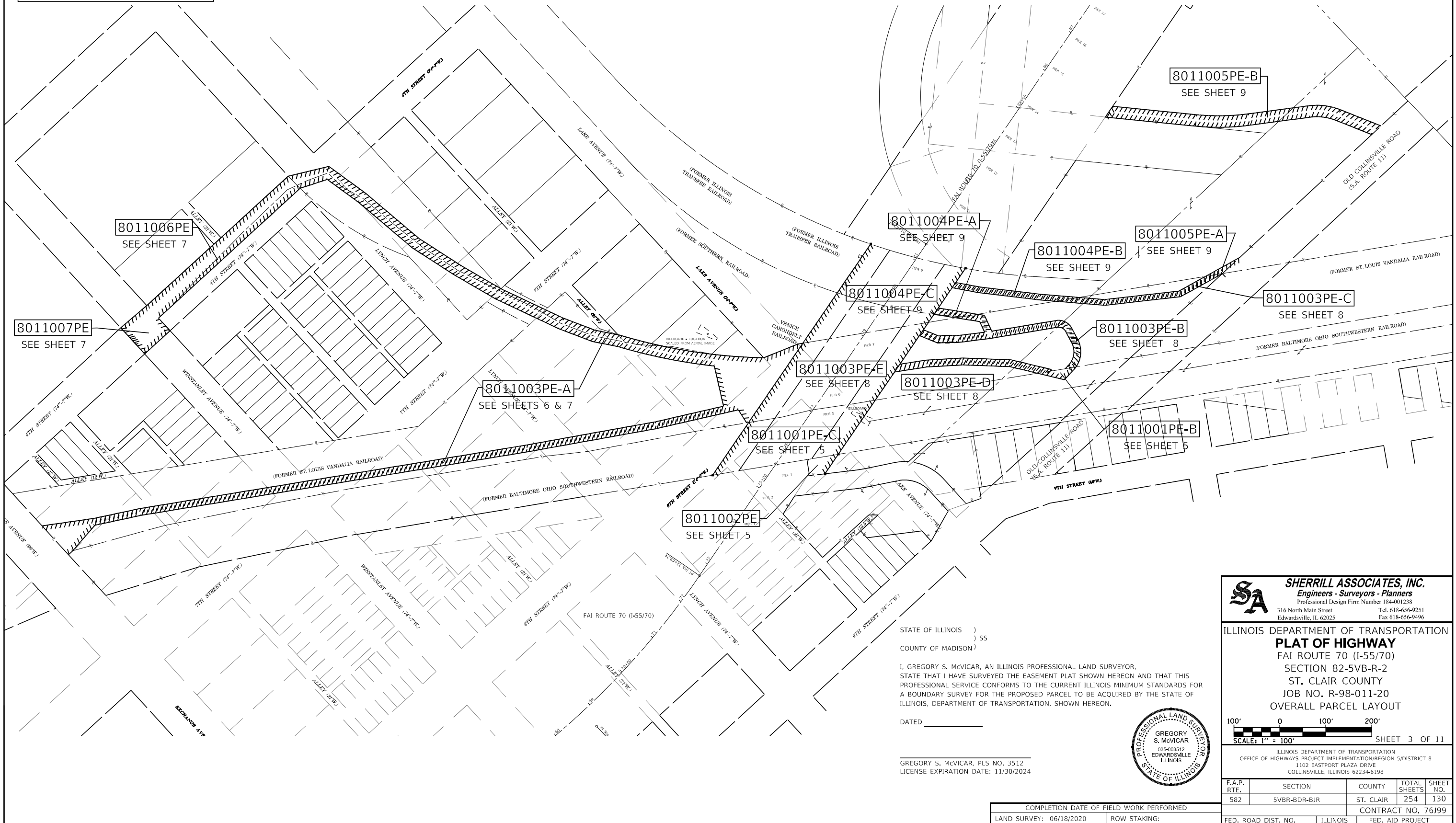

STATE OF ILLINOIS)
) SS
 COUNTY OF MADISON)

I, GREGORY S. McVICAR, AN ILLINOIS PROFESSIONAL LAND SURVEYOR, STATE THAT I HAVE SURVEYED THE EASEMENT PLAT SHOWN HEREON AND THAT THIS PROFESSIONAL SERVICE CONFORMS TO THE CURRENT ILLINOIS MINIMUM STANDARDS FOR A BOUNDARY SURVEY FOR THE PROPOSED PARCEL TO BE ACQUIRED BY THE STATE OF ILLINOIS, DEPARTMENT OF TRANSPORTATION, SHOWN HEREON.

DATED _____

GREGORY S. McVICAR, PLS NO. 3512
 LICENSE EXPIRATION DATE: 11/30/2024



SA **SHERRILL ASSOCIATES, INC.**
 Engineers - Surveyors - Planners
 Professional Design Firm Number 184-001238
 316 North Main Street Tel. 618-656-9251
 Edwardsville, IL 62025 Fax 618-656-9496

ILLINOIS DEPARTMENT OF TRANSPORTATION
PLAT OF HIGHWAY
 FAI ROUTE 70 (I-55/70)
 SECTION 82-5VB-R-2
 ST. CLAIR COUNTY
 JOB NO. R-98-011-20
 OVERALL PARCEL LAYOUT



ILLINOIS DEPARTMENT OF TRANSPORTATION
 OFFICE OF HIGHWAYS PROJECT IMPLEMENTATION/REGION 5/DISTRICT 8
 1102 EASTPORT PLAZA DRIVE
 COLLINSVILLE, ILLINOIS 62234-6198

F.A.P. RTE.	SECTION	COUNTY	TOTAL SHEETS	SHEET NO.
582	5VBR-BDR-BJR	ST. CLAIR	254	130
				CONTRACT NO. 76J99
FED. ROAD DIST. NO.	ILLINOIS	FED. AID PROJECT		

COMPLETION DATE OF FIELD WORK PERFORMED	
LAND SURVEY: 06/18/2020	ROW STAKING:

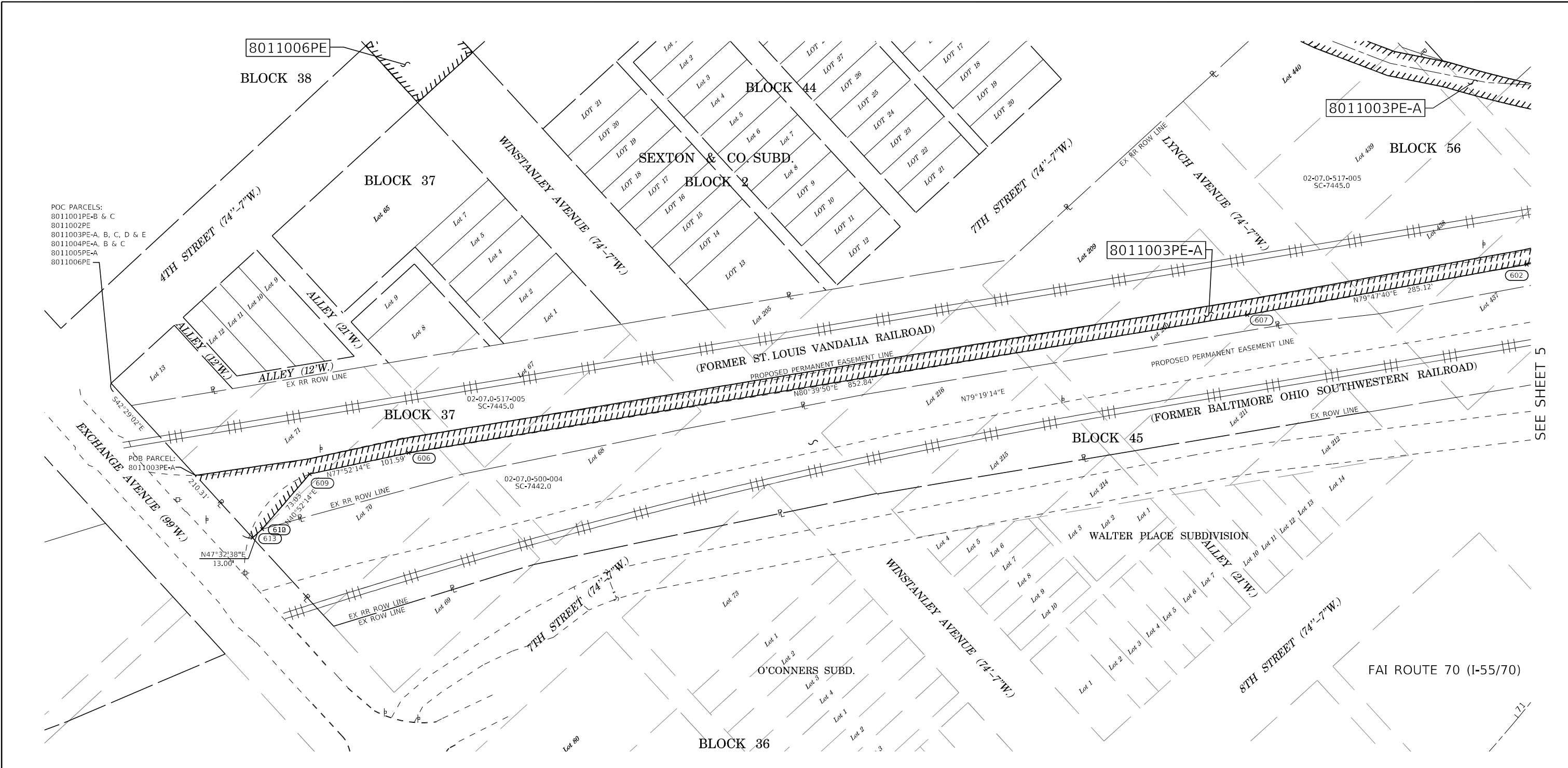

POC PARCELS:
 8011001PE-B & C
 8011002PE
 8011003PE-A, B, C, D & E
 8011004PE-A, B & C
 8011005PE-A
 8011006PE

POB PARCEL:
 8011003PE-A

SEE LEGENDS, TOPOGRAPHIC STATEMENT, SURVEYORS NOTE(S) AND BASIS OF COORDINATES & BEARINGS STATEMENT ON SHEET 2

SEE SHEET 10 FOR PARCEL COORDINATE TABLES



SPACE RESERVED FOR RECORDING OFFICER

SEE SHEET 5 FOR PARCEL TABLE

STATE OF ILLINOIS)
) SS
 COUNTY OF MADISON)

I, GREGORY S. McVICAR, AN ILLINOIS PROFESSIONAL LAND SURVEYOR, STATE THAT I HAVE SURVEYED THE EASEMENT PLAT SHOWN HEREON AND THAT THIS PROFESSIONAL SERVICE CONFORMS TO THE CURRENT ILLINOIS MINIMUM STANDARDS FOR A BOUNDARY SURVEY FOR THE PROPOSED PARCEL TO BE ACQUIRED BY THE STATE OF ILLINOIS, DEPARTMENT OF TRANSPORTATION, SHOWN HEREON.

DATED _____

GREGORY S. McVICAR, PLS NO. 3512
 LICENSE EXPIRATION DATE: 11/30/2024



SA **SHERRILL ASSOCIATES, INC.**
 Engineers - Surveyors - Planners
 Professional Design Firm Number 184-001238
 316 North Main Street, Edwardsville, IL 62025
 Tel. 618-656-9251 Fax 618-656-9496

ILLINOIS DEPARTMENT OF TRANSPORTATION
PLAT OF HIGHWAY
 FAI ROUTE 70 (I-55/70)
 SECTION 82-5VB-R-2
 ST. CLAIR COUNTY
 JOB NO. R-98-011-20
 PARCELS 8011001 & 8011002

50' 0 50' 100'
 SCALE: 1" = 50' SHEET 4 OF 11

ILLINOIS DEPARTMENT OF TRANSPORTATION
 OFFICE OF HIGHWAYS PROJECT IMPLEMENTATION/REGION 5/DISTRICT 8
 1102 EASTPORT PLAZA DRIVE
 COLLINGSVILLE, ILLINOIS 62234-6198

F.A.I. RTE.	SECTION	COUNTY	TOTAL SHEETS	SHEET NO.
70	82-5VB-R-2	ST. CLAIR	254	131
CONTRACT NO. 76K02				
FED. ROAD DIST. NO.	ILLINOIS	FED. AID PROJECT		

COMPLETION DATE OF FIELD WORK PERFORMED
 LAND SURVEY: 06/18/2020 ROW STAKING:

SEE SHEET 5

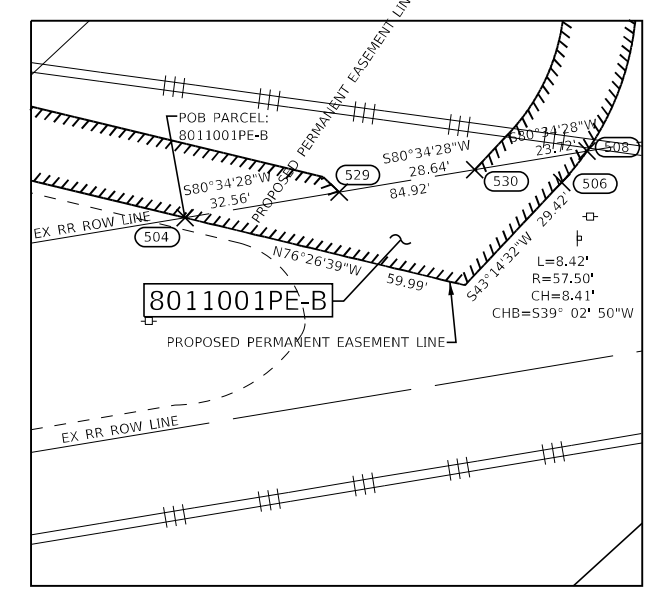
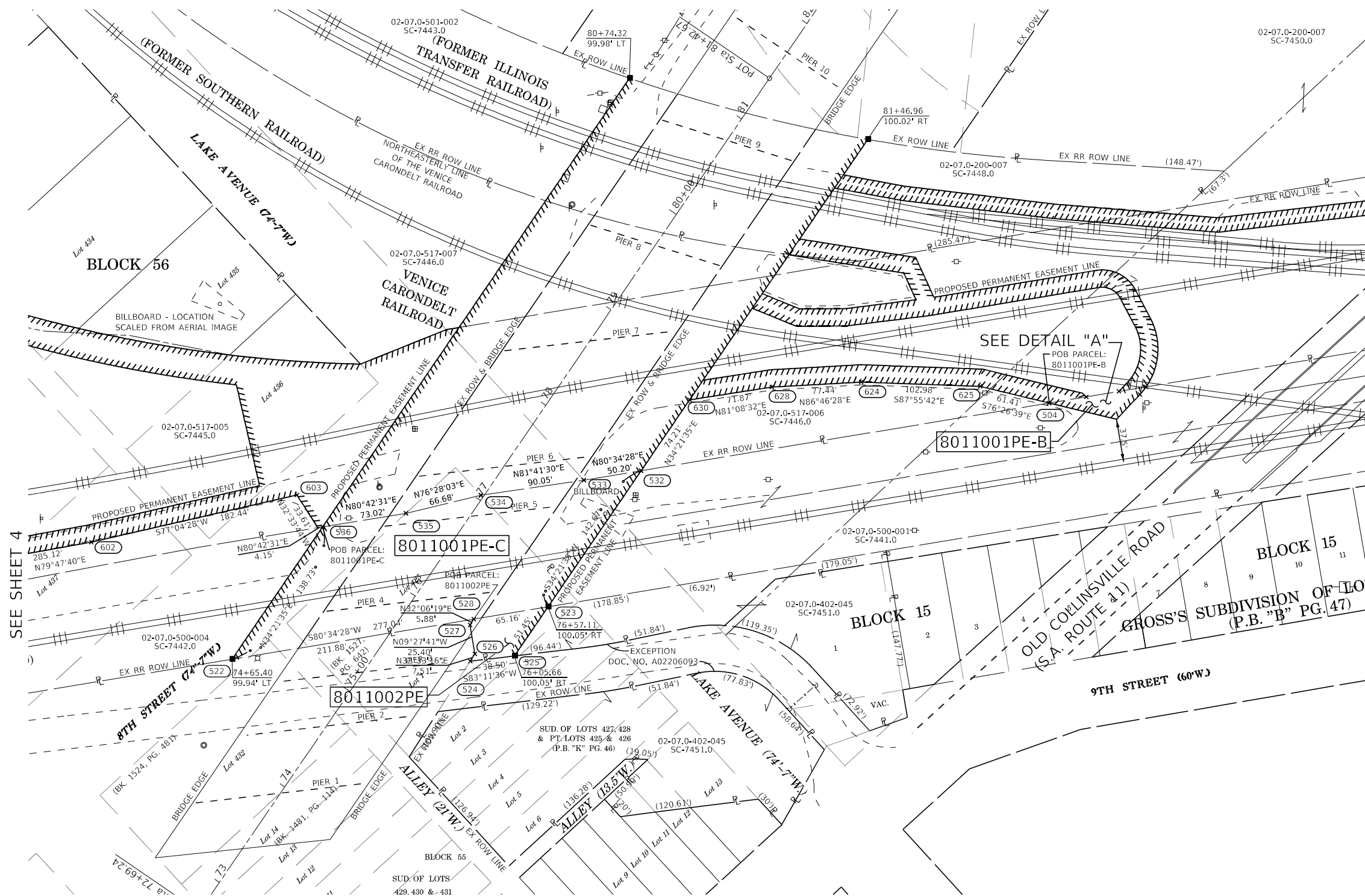

DETAIL "A"
SCALE: 1"=20'

SEE LEGENDS, TOPOGRAPHIC STATEMENT, SURVEYORS NOTE(S) AND BASIS OF COORDINATES & BEARINGS STATEMENT ON SHEET 2

SEE SHEET 10 PARCEL COORDINATE TABLES

SPACE RESERVED FOR RECORDING OFFICER



PARCEL NO.	OWNER	TOTAL HOLDING ACRES	EASEMENTS		EASEMENT PURPOSE	PERMANENT TAX NUMBER AFFECTED	PROPERTY ACQUIRED BY
			PE = PERMANENT ACRES	TE = TEMPORARY SQ FT			
8011001	CSX TRANSPORTATION, INC. TITLE REPORT NO. SC-7441.0 & SC-7442.0	N/A	PE-B=0.0230 PE-C=0.6511	PE-B=1,004 PE-C=28,361	PE-B=ACCESS PE-C=BRIDGE MAINTENANCE, CONSTRUCTION AND RE-CONSTRUCTION	PE-B=02-07.0-500-001 PE-C=02-07.0-500-004; 02-07.0-500-001	
8011002	AMEREN ILLINOIS COMPANY D/B/A AMERENCIPI, TITLE REPORT NO. SC-7451.0	1.39	PE=0.0432	PE=1,884	PE=BRIDGE MAINTENANCE, CONSTRUCTION AND RE-CONSTRUCTION	PE=02-07.0-402-045	

STATE OF ILLINOIS)
COUNTY OF MADISON) 55

I, GREGORY S. McVICAR, AN ILLINOIS PROFESSIONAL LAND SURVEYOR, STATE THAT I HAVE SURVEYED THE EASEMENT PLAT SHOWN HEREON AND THAT THIS PROFESSIONAL SERVICE CONFORMS TO THE CURRENT ILLINOIS MINIMUM STANDARDS FOR A BOUNDARY SURVEY FOR THE PROPOSED PARCEL TO BE ACQUIRED BY THE STATE OF ILLINOIS, DEPARTMENT OF TRANSPORTATION, SHOWN HEREON.

DATED _____

GREGORY S. McVICAR, PLS NO. 3512
LICENSE EXPIRATION DATE: 11/30/2024



SA **SHERRILL ASSOCIATES, INC.**
Engineers - Surveyors - Planners
Professional Design Firm Number 184-001238
316 North Main Street, Edwardsville, IL 62025
Tel. 618-656-9251, Fax 618-656-9496

ILLINOIS DEPARTMENT OF TRANSPORTATION
PLAT OF HIGHWAY
FAI ROUTE 70 (I-55/70)
SECTION 82-5VB-R-2
ST. CLAIR COUNTY
JOB NO. R-98-011-20
PARCELS 8011001 & 8011002

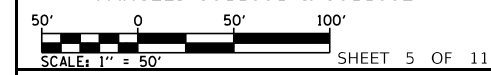

ILLINOIS DEPARTMENT OF TRANSPORTATION
OFFICE OF HIGHWAYS PROJECT IMPLEMENTATION/REGION 5/DISTRICT 8
1102 EASTPORT PLAZA DRIVE
COLLINSVILLE, ILLINOIS 62234-6198

F.A.I. RTE.	SECTION	COUNTY	TOTAL SHEETS	SHEET NO.
70	82-5VB-R-2	ST. CLAIR	254	132

CONTRACT NO. 76K02

COMPLETION DATE OF FIELD WORK PERFORMED	
LAND SURVEY: 06/18/2020	ROW STAKING:

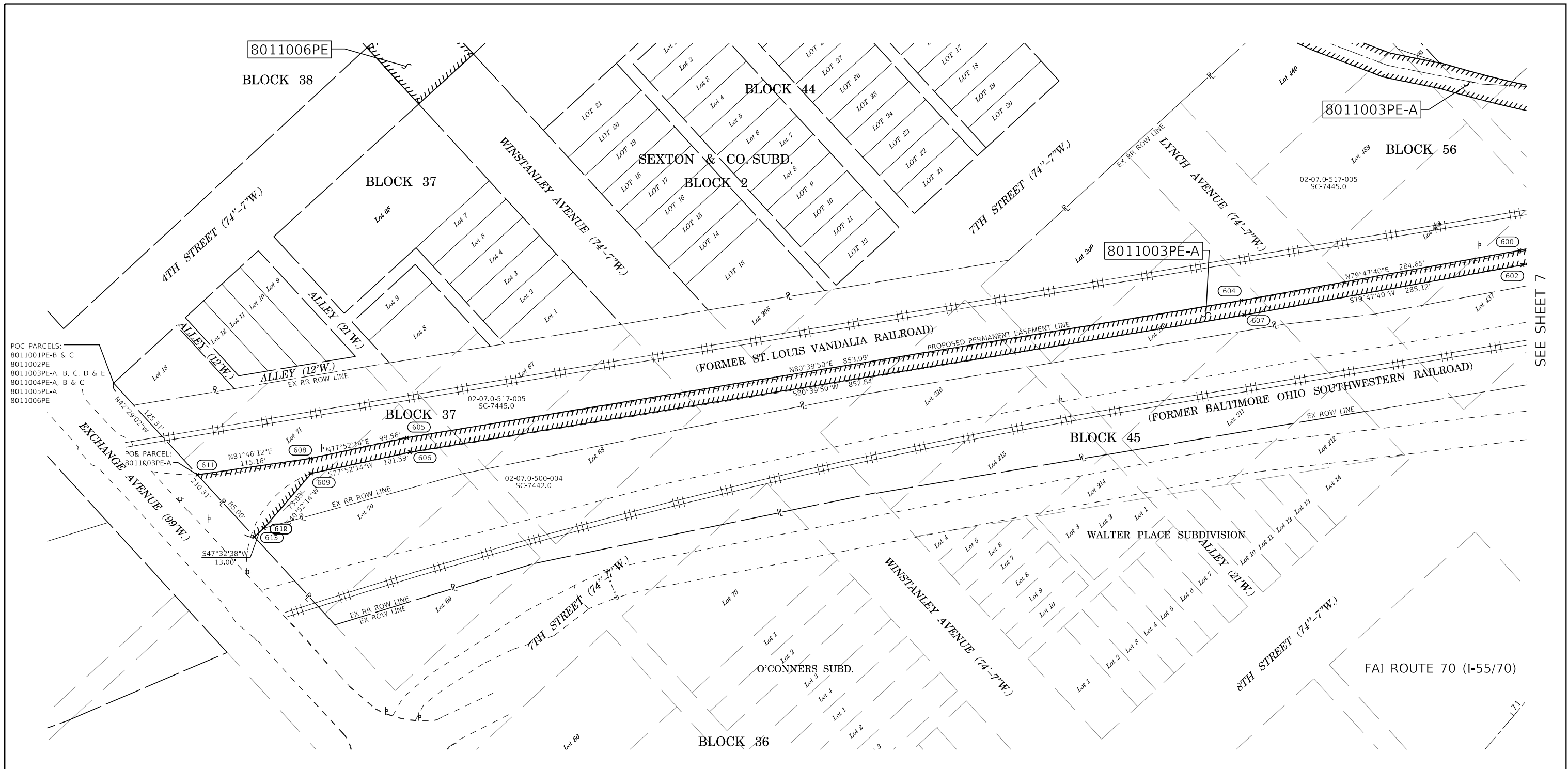

SEE SHEET 7

POC PARCELS:
8011001PE-B & C
8011002PE
8011003PE-A, B, C, D & E
8011004PE-A, B & C
8011005PE-A
8011006PE

POB PARCEL:
8011003PE-A

SEE LEGENDS, TOPOGRAPHIC STATEMENT, SURVEYORS NOTE(S) AND BASIS OF COORDINATES & BEARINGS STATEMENT ON SHEET 2

SEE SHEET 10 FOR PARCEL COORDINATE TABLES

SPACE RESERVED FOR RECORDING OFFICER

SEE SHEET 8 FOR PARCEL TABLE

STATE OF ILLINOIS)
) SS
COUNTY OF MADISON)

I, GREGORY S. McVICAR, AN ILLINOIS PROFESSIONAL LAND SURVEYOR, STATE THAT I HAVE SURVEYED THE EASEMENT PLAT SHOWN HEREON AND THAT THIS PROFESSIONAL SERVICE CONFORMS TO THE CURRENT ILLINOIS MINIMUM STANDARDS FOR A BOUNDARY SURVEY FOR THE PROPOSED PARCEL TO BE ACQUIRED BY THE STATE OF ILLINOIS, DEPARTMENT OF TRANSPORTATION, SHOWN HEREON.

DATED _____

GREGORY S. McVICAR, PLS NO. 3512
LICENSE EXPIRATION DATE: 11/30/2024



SA **SHERRILL ASSOCIATES, INC.**
Engineers - Surveyors - Planners
Professional Design Firm Number 184-001238
316 North Main Street Tel. 618-656-9251
Edwardsville, IL 62025 Fax 618-656-9496

ILLINOIS DEPARTMENT OF TRANSPORTATION
PLAT OF HIGHWAY
FAI ROUTE 70 (I-55/70)
SECTION 82-5VB-R-2
ST. CLAIR COUNTY
JOB NO. R-98-011-20
PARCELS 8011001 & 8011002

50' 0 50' 100'
SCALE: 1" = 50' SHEET 6 OF 11

ILLINOIS DEPARTMENT OF TRANSPORTATION
OFFICE OF HIGHWAYS PROJECT IMPLEMENTATION/REGION 5/DISTRICT 8
1102 EASTPORT PLAZA DRIVE
COLLINSVILLE, ILLINOIS 62234-6198

F.A.I. RTE.	SECTION	COUNTY	TOTAL SHEETS	SHEET NO.
70	82-5VB-R-2	ST. CLAIR	254	133
CONTRACT NO. 76K02				
FED. ROAD DIST. NO.	ILLINOIS	FED. AID PROJECT		

COMPLETION DATE OF FIELD WORK PERFORMED
LAND SURVEY: 06/18/2020 ROW STAKING:

ILLINOIS CITY
(D.B. "I" PG. 26)

BLOCK 43

SEE SHEET 11 FOR
TOTAL HOLDING SKETCH

BLOCK 57

02-07.0-501-002
SC-7443.0

02-07.0-517-007
SC-7446.0

02-07.0-517-003
SC-7444.0

L=36.86' R=670.92' CH=36.85' CHB=544° 06' 33"E

8011006PE

02-07.0-xxx-xxx
SC-7447.0

PROPOSED PERMANENT EASEMENT LINE

PROPOSED PERMANENT EASEMENT LINE

PROPOSED PERMANENT EASEMENT LINE

PROPOSED PERMANENT EASEMENT LINE

PROPOSED PERMANENT EASEMENT LINE

PROPOSED PERMANENT EASEMENT LINE

PROPOSED PERMANENT EASEMENT LINE

PROPOSED PERMANENT EASEMENT LINE

PROPOSED PERMANENT EASEMENT LINE

PROPOSED PERMANENT EASEMENT LINE

PROPOSED PERMANENT EASEMENT LINE

PROPOSED PERMANENT EASEMENT LINE

PROPOSED PERMANENT EASEMENT LINE

PROPOSED PERMANENT EASEMENT LINE

PROPOSED PERMANENT EASEMENT LINE

PROPOSED PERMANENT EASEMENT LINE

PROPOSED PERMANENT EASEMENT LINE

PROPOSED PERMANENT EASEMENT LINE

PROPOSED PERMANENT EASEMENT LINE

PROPOSED PERMANENT EASEMENT LINE

PROPOSED PERMANENT EASEMENT LINE

PROPOSED PERMANENT EASEMENT LINE

PROPOSED PERMANENT EASEMENT LINE

PROPOSED PERMANENT EASEMENT LINE

PROPOSED PERMANENT EASEMENT LINE

PROPOSED PERMANENT EASEMENT LINE

PROPOSED PERMANENT EASEMENT LINE

PROPOSED PERMANENT EASEMENT LINE

PROPOSED PERMANENT EASEMENT LINE

PROPOSED PERMANENT EASEMENT LINE

PROPOSED PERMANENT EASEMENT LINE

PROPOSED PERMANENT EASEMENT LINE

PROPOSED PERMANENT EASEMENT LINE

PROPOSED PERMANENT EASEMENT LINE

PROPOSED PERMANENT EASEMENT LINE

PROPOSED PERMANENT EASEMENT LINE

PROPOSED PERMANENT EASEMENT LINE

PROPOSED PERMANENT EASEMENT LINE

PROPOSED PERMANENT EASEMENT LINE

8011007PE

X 38

BLOCK 37

WINSTANLEY AVENUE (74'-7"W.)

SEXTON & CO. SUBD.

BLOCK 44

SEXTON & CO. SUBD.

BLOCK 1

LYNCH AVENUE (74'-7"W.)

7TH STREET (74'-7"W.)

BLOCK 56

BLOCK 56

BILLBOARD - LOCATION
SCALED FROM AERIAL IMAGE
CH=314.71' CHB=581° 05' 35"E

8011003PE-A

SEE SHEET 6

SEE SHEET 8

SEE LEGENDS, TOPOGRAPHIC STATEMENT, SURVEYORS NOTE(S) AND BASIS OF COORDINATES & BEARINGS STATEMENT ON SHEET 2

SEE SHEET 10 FOR PARCEL COORDINATE TABLES



SEE SHEET 8 FOR PARCEL 8011003 TABLE

PARCEL NO.	OWNER	TOTAL HOLDING ACRES	EASEMENTS			PERMANENT TAX NUMBER AFFECTED	PROPERTY ACQUIRED BY
			PE = PERMANENT TE = TEMPORARY	ACRES	SQ FT		
8011006	MISSION DEVELOPMENT LAND TRUST TITLE REPORT NO. SC-7447.0	12.13	PE=0.3550	PE=15,465	PE=ACCESS	PE=02-07.0-102-055 (PT)	
8011007	TANK TRAILER CLEANING, INC., AND THE CITY OF EAST ST. LOUIS, AS THEIR INTERESTS MAY APPEAR, TITLE REPORT NO. SC-7494.0	3.68	PE=0.1302	PE=5,671	PE=ACCESS	PE=02-07.0-105-075 (PT)	

STATE OF ILLINOIS)
) SS
COUNTY OF MADISON)

I, GREGORY S. McVICAR, AN ILLINOIS PROFESSIONAL LAND SURVEYOR, STATE THAT I HAVE SURVEYED THE EASEMENT PLAT SHOWN HEREON AND THAT THIS PROFESSIONAL SERVICE CONFORMS TO THE CURRENT ILLINOIS MINIMUM STANDARDS FOR A BOUNDARY SURVEY FOR THE PROPOSED PARCEL TO BE ACQUIRED BY THE STATE OF ILLINOIS, DEPARTMENT OF TRANSPORTATION, SHOWN HEREON.

DATED _____

GREGORY S. McVICAR, PLS NO. 3512
LICENSE EXPIRATION DATE: 11/30/2024



SA **SHERRILL ASSOCIATES, INC.**
Engineers - Surveyors - Planners
Professional Design Firm Number 184-001238
316 North Main Street
Edwardsville, IL 62025
Tel. 618-656-9251
Fax 618-656-9496

ILLINOIS DEPARTMENT OF TRANSPORTATION
PLAT OF HIGHWAY
FAI ROUTE 70 (I-55/70)
SECTION 82-5VB-R-2
ST. CLAIR COUNTY
JOB NO. R-98-011-20
PARCELS 8011003

50'		0		50'		100'	
SCALE: 1" = 50'							
SHEET 7 OF 11							
ILLINOIS DEPARTMENT OF TRANSPORTATION OFFICE OF HIGHWAYS PROJECT IMPLEMENTATION/REGION 5/DISTRICT 8 1102 EASTPORT PLAZA DRIVE COLLINSVILLE, ILLINOIS 62234-6198							
F.A.I. RTE.	SECTION	COUNTY	TOTAL SHEETS	SHEET NO.			
70	82-5VB-R-2	ST. CLAIR	254	134			
FED. ROAD DIST. NO.			ILLINOIS		FED. AID PROJECT		

COMPLETION DATE OF FIELD WORK PERFORMED
LAND SURVEY: 06/18/2020
ROW STAKING:

SPACE RESERVED FOR RECORDING OFFICER

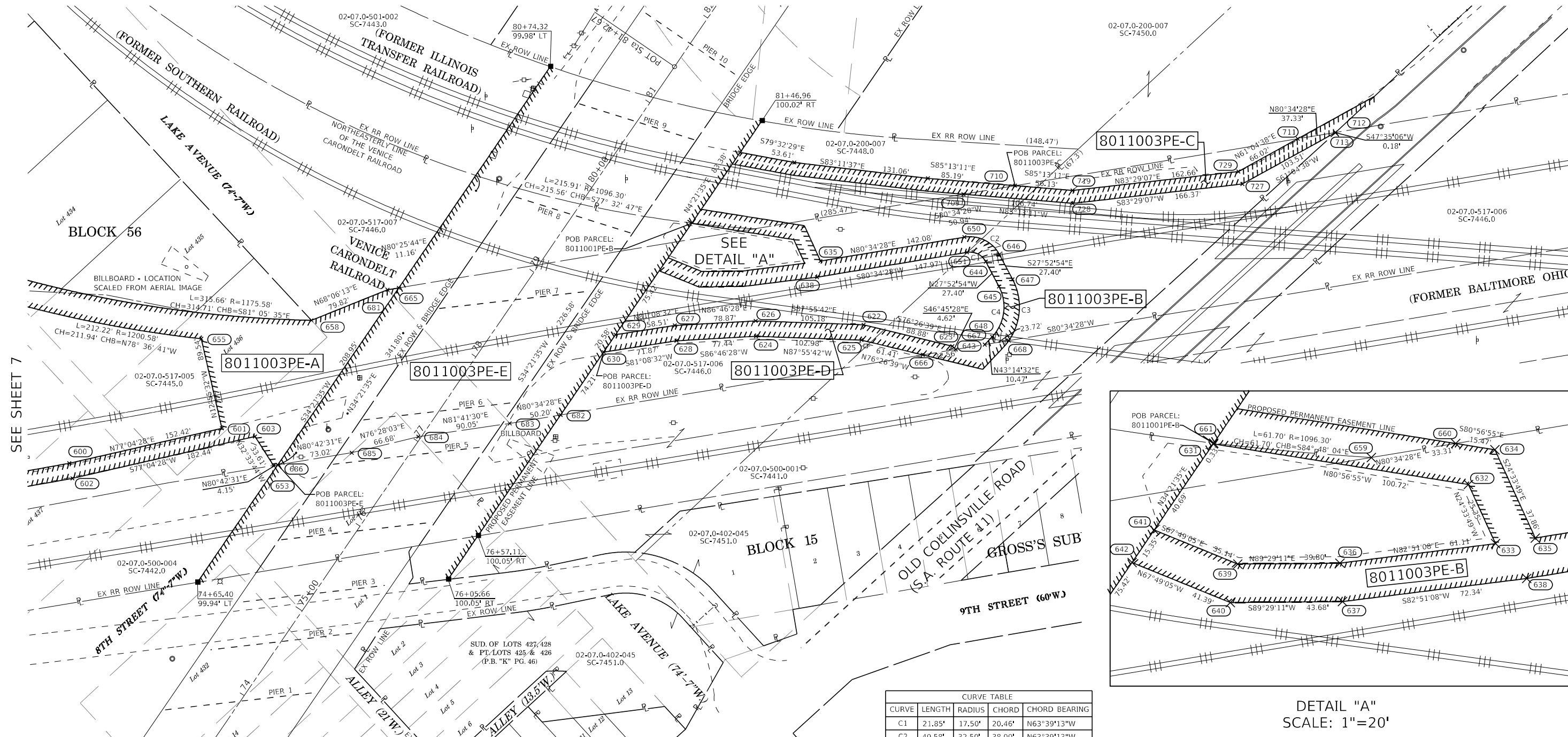

SEE LEGENDS, TOPOGRAPHIC STATEMENT, SURVEYORS NOTE(S) AND BASIS OF COORDINATES & BEARINGS STATEMENT ON SHEET 2

SEE SHEET 10 PARCEL COORDINATE TABLES

SPACE RESERVED FOR RECORDING OFFICER



PARCEL NO.	OWNER	TOTAL HOLDING	EASEMENTS		EASEMENT PURPOSE	PERMANENT TAX NUMBER AFFECTED	PROPERTY ACQUIRED BY
			PE = PERMANENT	TE = TEMPORARY			
8011003	GATEWAY EASTERN RAILWAY COMPANY TITLE REPORT NO. SC-7444.0, SC-7445.0 & SC-7446.0	N/A	PE-A=1.5491 PE-B=0.1698 PE-C=0.0949 PE-D=0.1124 PE-E=1.2822	PE-A=67,478 PE-B=7,398 PE-C=4,136 PE-D=4,898 PE-E=55,853	PE-A, B, C & D=ACCESS PE-E=BRIDGE MAINTENANCE, CONSTRUCTION AND RE-CONSTRUCTION	PE-A=02-07.0-517-003; 02-07.0-517-005 PE-B=02-07.0-517-006 PE-C=02-07.0-517-006 PE-D=02-07.0-517-006 PE-E=02-07.0-517-005; 02-07.0-517-006	

STATE OF ILLINOIS)
COUNTY OF MADISON)

I, GREGORY S. McVICAR, AN ILLINOIS PROFESSIONAL LAND SURVEYOR, STATE THAT I HAVE SURVEYED THE EASEMENT PLAT SHOWN HEREON AND THAT THIS PROFESSIONAL SURVEY CONFORMS TO THE CURRENT ILLINOIS MINIMUM STANDARDS FOR A BOUNDARY SURVEY FOR THE PROPOSED PARCEL TO BE ACQUIRED BY THE STATE OF ILLINOIS, DEPARTMENT OF TRANSPORTATION, SHOWN HEREON.

DATED _____

GREGORY S. McVICAR, PLS NO. 3512
LICENSE EXPIRATION DATE: 11/30/2024



COMPLETION DATE OF FIELD WORK PERFORMED
LAND SURVEY: 06/18/2020 ROW STAKING:

DETAIL "A"
SCALE: 1"=20'

SHERRILL ASSOCIATES, INC.
Engineers - Surveyors - Planners
Professional Design Firm Number 184-001238
316 North Main Street, Edwardsville, IL 62025
Tel. 618-656-9251, Fax 618-656-9496

ILLINOIS DEPARTMENT OF TRANSPORTATION
PLAT OF HIGHWAY
FAI ROUTE 70 (I-55/70)
SECTION 82-5VB-R-2
ST. CLAIR COUNTY
JOB NO. R-98-011-20
PARCELS 8011003

F.A.I. RTE.	SECTION	COUNTY	TOTAL SHEETS	SHEET NO.
70	82-5VB-R-2	ST. CLAIR	254	135
CONTRACT NO. 76K02				
FED. ROAD DIST. NO.	ILLINOIS	FED. AID PROJECT		

LOT 49
 FIRST SUBDIVISION OF THE
 CAHOKIA COMMONS
 (D.B. "M" PG. 11)

SEE SHEET 11 FOR
 TOTAL HOLDING SKETCH

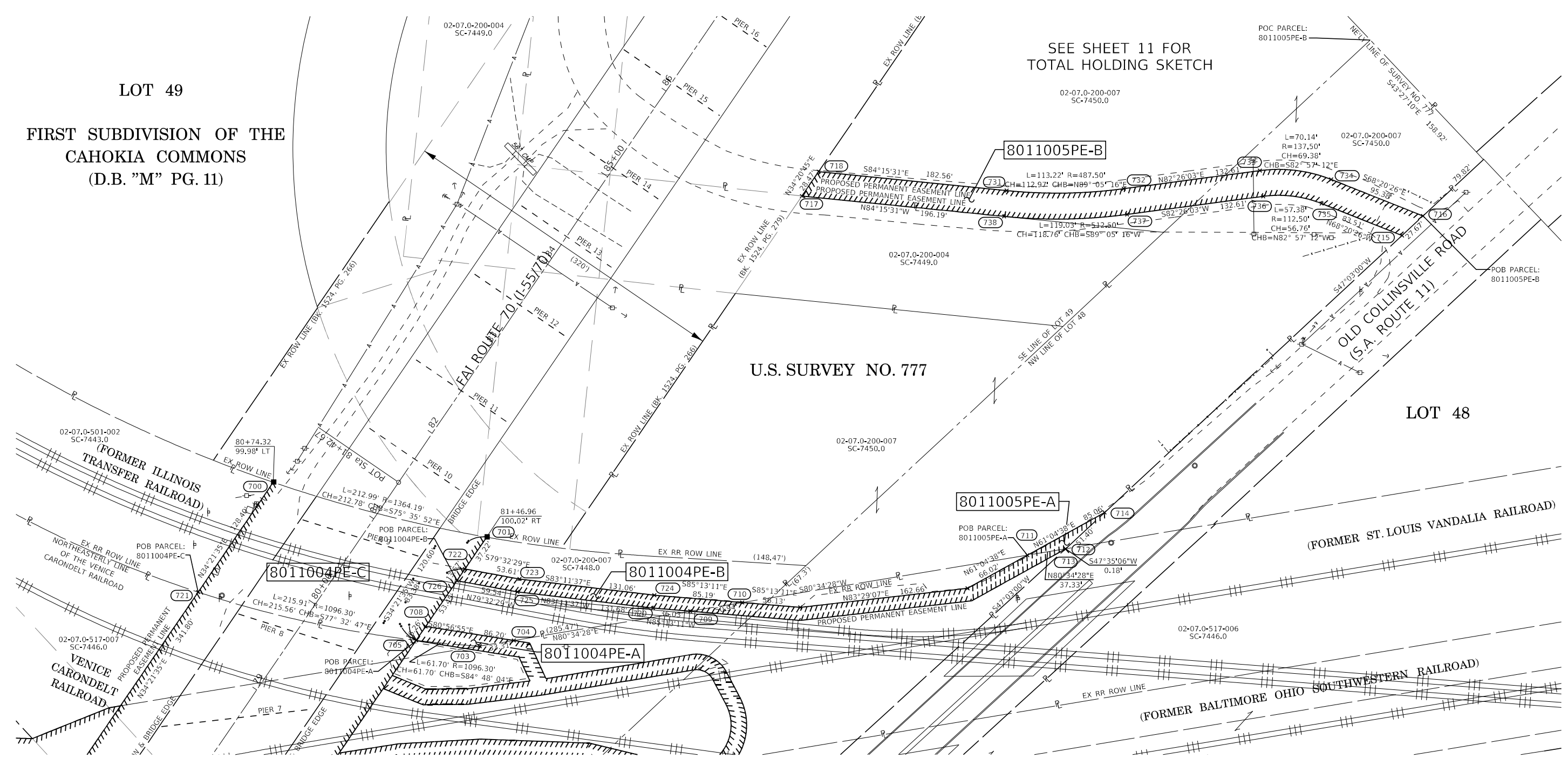

SEE LEGENDS, TOPOGRAPHIC STATEMENT, SURVEYORS NOTE(S) AND BASIS OF COORDINATES & BEARINGS STATEMENT ON SHEET 2

SEE SHEET 10 PARCEL COORDINATE TABLES

SPACE RESERVED FOR RECORDING OFFICER

PARCEL NO.	OWNER	TOTAL HOLDING ACRES	EASEMENTS		EASEMENT PURPOSE	PERMANENT TAX NUMBER AFFECTED	PROPERTY ACQUIRED BY
			PE = PERMANENT ACRES	TE = TEMPORARY SQ FT			
8011004	TERMINAL RAILROAD ASSOCIATION OF ST. LOUIS, A MISSOURI CORPORATION TITLE REPORT NO. SC-7443.0 & SC-7448.0	N/A	PE-A=0.0209 PE-B=0.0713 PE-C=0.5756	PE-A=911 PE-B=3,107 PE-C=25,074	PE-A & B=ACCESS PE-C=BRIDGE MAINTENANCE, CONSTRUCTION AND RE-CONSTRUCTION	PE-A=02-07.0-500-004 PE-B=02-07.0-500-001 PE-C=02-07.0-500-004; 02-07.0-500-001	
8011005	SPEEDWAY INVESTORS, LLC AN ILLINOIS LIMITED LIABILITY COMPANY TITLE REPORT NO. SC-7450.0	21.02	PE-A=0.0122 PE-B=0.3394	PE-A=530 PE-B=14,783	PE-A & B=ACCESS	PE-A=02-07.0-200-007; 02-07.0-200-014 PE-B=02-07.0-200-007	

STATE OF ILLINOIS)
) SS
 COUNTY OF MADISON)

I, GREGORY S. McVICAR, AN ILLINOIS PROFESSIONAL LAND SURVEYOR, STATE THAT I HAVE SURVEYED THE EASEMENT PLAT SHOWN HEREON AND THAT THIS PROFESSIONAL SERVICE CONFORMS TO THE CURRENT ILLINOIS MINIMUM STANDARDS FOR A BOUNDARY SURVEY FOR THE PROPOSED PARCEL TO BE ACQUIRED BY THE STATE OF ILLINOIS, DEPARTMENT OF TRANSPORTATION, SHOWN HEREON.

DATED _____

GREGORY S. McVICAR, PLS NO. 3512
 LICENSE EXPIRATION DATE: 11/30/2024



COMPLETION DATE OF FIELD WORK PERFORMED
 LAND SURVEY: 06/18/2020 ROW STAKING:

SHERRILL ASSOCIATES, INC.
 Engineers - Surveyors - Planners
 Professional Design Firm Number 184-001238
 316 North Main Street, Tel. 618-656-9251
 Edwardsville, IL 62025 Fax 618-656-9496

ILLINOIS DEPARTMENT OF TRANSPORTATION
PLAT OF HIGHWAY
 FAI ROUTE 70 (I-55/70)
 SECTION 82-5VB-R-2
 ST. CLAIR COUNTY
 JOB NO. R-98-011-20
 PARCELS 8011004 & 8011005

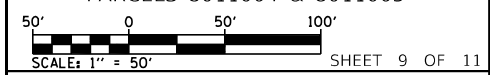

ILLINOIS DEPARTMENT OF TRANSPORTATION
 OFFICE OF HIGHWAYS PROJECT IMPLEMENTATION/REGION 5/DISTRICT 8
 1102 EASTPORT PLAZA DRIVE
 COLLINSVILLE, ILLINOIS 62234-6198

F.A.I. RTE.	SECTION	COUNTY	TOTAL SHEETS	SHEET NO.
70	82-5VB-R-2	ST. CLAIR	254	136

CONTRACT NO. 76K02
 FED. ROAD DIST. NO. ILLINOIS FED. AID PROJECT

PARCELS 8011001 & 8011002

Point #	Northing	Easting
508	159402.6700	42867.3161
504	159388.7630	42783.5427
506	159396.1369	42862.0168
509	159435.5291	42820.1301

Point #	Northing	Easting
522	159167.0476	42076.9117
523	159212.4161	42350.2038
524	159165.3791	42282.9351
525	159169.9423	42321.1653
526	159171.7103	42286.9770
527	159196.7648	42282.8017
528	159201.7456	42285.9268
529	159394.0952	42815.6629
530	159398.7855	42843.9164
532	159330.1929	42430.7259
533	159321.9725	42381.2075
534	159308.9598	42292.0977
535	159293.3559	42227.2650
536	159281.5670	42155.2068

PARCELS 8011003, 8011006 & 8011007

Point #	Northing	Easting
608	159073.3636	40732.9292
600	159283.1109	41952.1999
601	159317.2057	42100.7625
602	159268.4113	41955.2081
603	159309.2202	42133.0261
604	159232.6772	41672.0544
605	159094.2832	40830.2659
606	159079.5412	40833.0602
607	159217.8944	41674.6001
609	159058.1954	40733.7403
610	159002.9694	40685.9514
611	159056.8783	40618.9520
612	159002.9694	40685.9513
613	158994.1935	40676.3594
614	159508.6791	40872.0094
615	159481.3077	40897.3374
616	159430.7954	40842.1124
617	159487.6665	40789.8590
618	159536.0484	40846.6835
619	159817.4943	41154.3807

Point #	Northing	Easting
620	159787.4485	41183.7312
620	159791.0334	41180.0315
622	159418.0920	42725.8962
623	159397.2597	42812.2980
624	159406.8785	42620.9388
625	159403.1563	42723.8466
626	159421.8938	42620.7876
627	159417.4558	42542.0398
628	159402.5211	42543.6205
629	159408.4460	42484.2262
630	159391.4546	42472.6095
631	159516.9662	42558.4196
632	159501.1200	42657.8897
633	159478.0660	42668.4269
634	159514.6683	42668.1898
635	159480.2340	42683.9286
636	159470.4624	42607.7933
637	159455.4708	42608.7971
638	159464.4719	42680.5749
639	159470.1056	42567.9927

Point #	Northing	Easting
640	159455.0792	42565.1170
641	159483.3731	42535.4526
642	159470.7054	42526.7919
643	159394.0952	42815.6629
644	159479.6246	42844.8823
645	159455.4042	42857.6964
646	159486.6393	42858.1410
647	159462.4189	42870.9552
648	159406.4131	42851.0898
649	159435.5291	42820.1301
650	159503.5020	42824.0914
651	159488.7045	42826.5479
652	159471.4407	42829.4138
653	159280.8973	42151.1130
654	159446.3285	41872.9624
655	159404.4772	42080.7339
657	159471.1609	41877.1575
658	159422.4342	42188.0701
659	159511.6471	42620.0478
660	159517.1025	42652.9099

PARCELS 8011004 & 8011005

Point #	Northing	Easting
709	159545.3660	42823.1647
701	159616.7931	42626.6697
711	159599.4136	43148.7385
703	159511.6471	42620.0478
712	159605.5267	43185.5629
704	159517.1025	42652.9099
705	159517.2377	42558.6053
708	159530.6635	42567.7843
710	159553.7076	42873.4131
713	159605.4072	43185.4320
714	159640.5487	43223.1851
715	159907.8728	43510.3569
716	159926.7281	43530.6121
717	159945.9356	42930.9935
718	159969.4464	42947.0591
719	159549.0300	42929.3480
720	159548.3689	42787.2560
721	159563.7237	42348.1125
722	159586.0707	42605.6653
723	159576.3400	42658.3800

Point #	Northing	Easting
724	159560.8070	42788.5180
725	159563.9753	42656.5028
726	159574.7839	42597.9487
727	159555.3466	43094.8322
728	159536.4705	42929.5381
729	159567.4850	43090.9540
731	159951.1839	43128.6984
732	159952.9823	43241.6529
733	159970.4429	43373.1133
734	159961.9316	43441.9665
735	159938.6968	43432.7393
736	159945.6605	43376.4049
737	159928.2000	43244.9445
738	159926.3093	43126.1975
700	159669.7172	42420.5785

Point #	Northing	Easting
661	159517.2377	42558.6053
663	158994.1935	40676.3594
665	159454.0572	42273.1354
666	159388.7630	42783.5427
667	159398.7855	42843.9164
668	159402.6700	42867.3161
669	159810.2267	41239.1309
670	159838.6693	41242.5651
671	159458.0235	41815.1193
672	159485.5129	41742.7799
673	159602.2067	41516.0596
674	159661.4899	41424.0812
675	159761.0062	41306.5804
676	159780.6678	41322.0476
677	159681.6204	41438.9949
678	159623.5332	41529.1177
679	159508.5376	41752.5681
680	159482.1345	41822.0487
681	159452.2021	42262.1337
682	159330.1929	42430.7259

Point #	Northing	Easting
683	159321.9725	42381.2075
684	159308.9598	42292.0977
685	159293.3559	42227.2650
686	159281.5670	42155.2068
687	159563.7237	42348.1125
688	159550.4001	41605.2339
689	159572.5542	41616.8676

SEE LEGENDS, TOPOGRAPHIC STATEMENT, SURVEYORS NOTE(S) AND BASIS OF COORDINATES & BEARINGS STATEMENT ON SHEET 2



SPACE RESERVED FOR RECORDING OFFICER

STATE OF ILLINOIS)
) SS
 COUNTY OF MADISON)

I, GREGORY S. McVICAR, AN ILLINOIS PROFESSIONAL LAND SURVEYOR, STATE THAT I HAVE SURVEYED THE EASEMENT PLAT SHOWN HEREON AND THAT THIS PROFESSIONAL SERVICE CONFORMS TO THE CURRENT ILLINOIS MINIMUM STANDARDS FOR A BOUNDARY SURVEY FOR THE PROPOSED PARCEL TO BE ACQUIRED BY THE STATE OF ILLINOIS, DEPARTMENT OF TRANSPORTATION, SHOWN HEREON.

DATED _____

GREGORY S. McVICAR, PLS NO. 3512
 LICENSE EXPIRATION DATE: 11/30/2024



ILLINOIS DEPARTMENT OF TRANSPORTATION
PLAT OF HIGHWAY
 FAI ROUTE 70 (I-55/70)
 SECTION 82-5VB-R-2
 ST. CLAIR COUNTY
 JOB NO. R-98-011-20
 COORDINATE TABLES

SHEET 10 OF 11

ILLINOIS DEPARTMENT OF TRANSPORTATION
 OFFICE OF HIGHWAYS PROJECT IMPLEMENTATION/REGION 5/DISTRICT 8
 1102 EASTPORT PLAZA DRIVE
 COLLINSVILLE, ILLINOIS 62234-6198

F.A.I. RTE.	SECTION	COUNTY	TOTAL SHEETS	SHEET NO.
70	82-5VB-R-2	ST. CLAIR	254	137
CONTRACT NO. 76K02				
FED. ROAD DIST. NO. -	ILLINOIS	FED. AID PROJECT		

COMPLETION DATE OF FIELD WORK PERFORMED	
LAND SURVEY: 06/18/2020	ROW STAKING:



SPACE RESERVED FOR RECORDING OFFICER

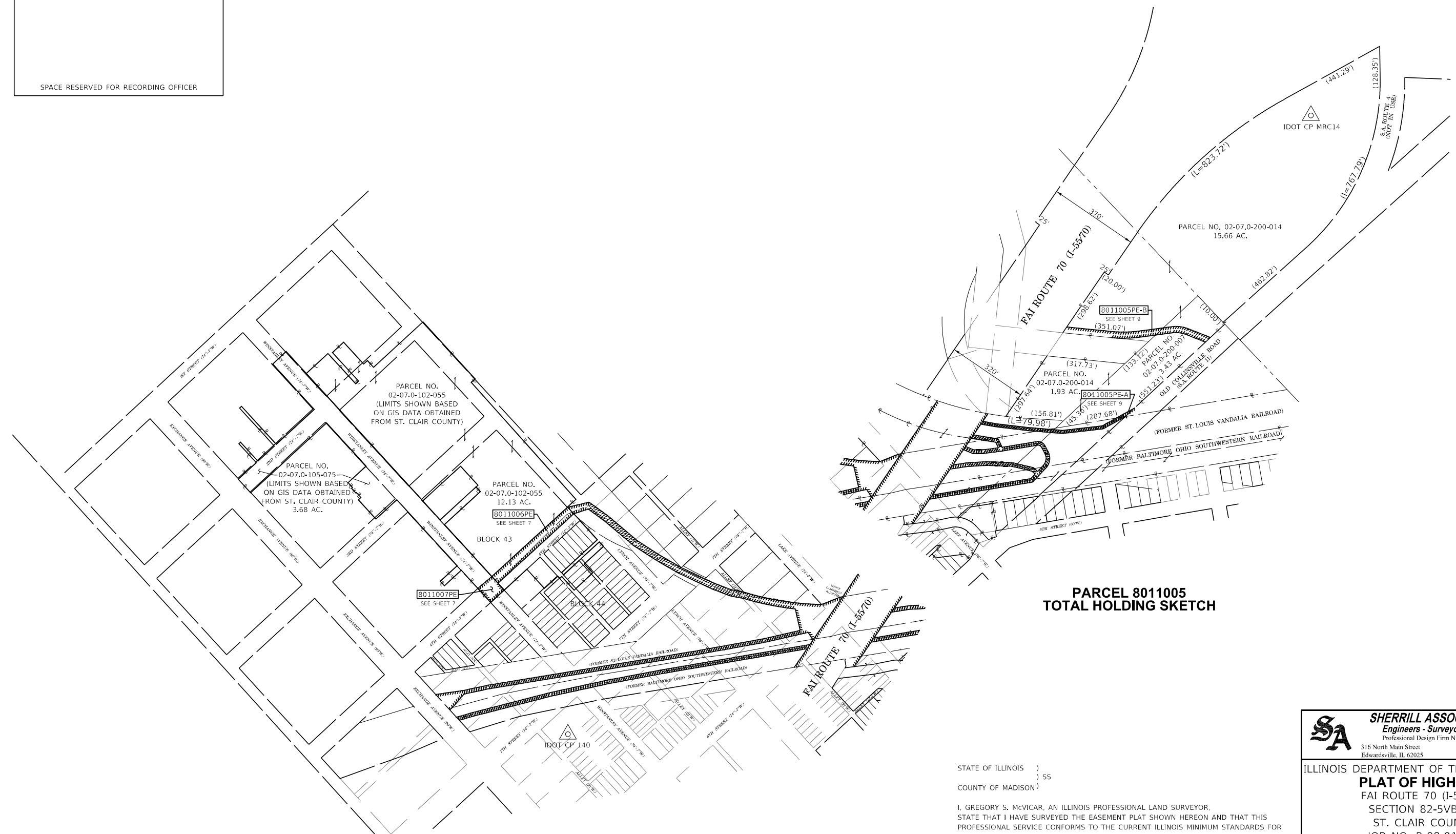

**PARCELS 8011006 & 8011007
TOTAL HOLDING SKETCH**

**PARCEL 8011005
TOTAL HOLDING SKETCH**

STATE OF ILLINOIS)
) SS
COUNTY OF MADISON)

I, GREGORY S. McVICAR, AN ILLINOIS PROFESSIONAL LAND SURVEYOR, STATE THAT I HAVE SURVEYED THE EASEMENT PLAT SHOWN HEREON AND THAT THIS PROFESSIONAL SERVICE CONFORMS TO THE CURRENT ILLINOIS MINIMUM STANDARDS FOR A BOUNDARY SURVEY FOR THE PROPOSED PARCEL TO BE ACQUIRED BY THE STATE OF ILLINOIS, DEPARTMENT OF TRANSPORTATION, SHOWN HEREON.

DATED _____

GREGORY S. McVICAR, PLS NO. 3512
LICENSE EXPIRATION DATE: 11/30/2022



SHERRILL ASSOCIATES, INC.
Engineers - Surveyors - Planners
Professional Design Firm Number 184-001238
316 North Main Street, Edwardsville, IL 62025
Tel. 618-656-9251, Fax 618-656-9496

ILLINOIS DEPARTMENT OF TRANSPORTATION
PLAT OF HIGHWAY
FAI ROUTE 70 (I-55/70)
SECTION 82-5VB-R-2
ST. CLAIR COUNTY
JOB NO. R-98-011-20
TOTAL HOLDING SKETCHES



ILLINOIS DEPARTMENT OF TRANSPORTATION
OFFICE OF HIGHWAYS PROJECT IMPLEMENTATION/REGION 5/DISTRICT 8
1102 EASTPORT PLAZA DRIVE
COLLINSVILLE, ILLINOIS 62234-6198

F.A.P. RTE.	SECTION	COUNTY	TOTAL SHEETS	SHEET NO.
582	5VBR-BDR-BJR	ST. CLAIR	254	138
			CONTRACT NO. 76J99	
FED. ROAD DIST. NO. _____		ILLINOIS	FED. AID PROJECT	

COMPLETION DATE OF FIELD WORK PERFORMED	
LAND SURVEY: 06/18/2020	ROW STAKING:

Benchmark: BM 207: Cut "□" on top of northeast end of parapet wall on the northeast end of the I-55/70 bridge (SN 082-0017) over RR tracks. Elev. 426.204.
 BM 208: Cut "□" on top southwest side of the southwest concrete overhead signpost foundation over I-55/70, north of I-55/70, just northwest of the I-55/70 bridge over the railroad (SN 082-0017). Elev. 437.486.

Existing Structure: S.N. 082-0017 originally built in 1959 as Section 82-5VB. The back-to-back length is 1618'-11³/₄" and out-to-out deck width is 116'-0". The structure is a 19 span multi-unit non-composite steel wide flange beam or built-up riveted plate girder bridge on stub abutments and multi-column spread footing piers founded on metal shell piles. Traffic to be maintained using staged construction.

Salvage: None

DESIGN STRESSES

FIELD UNITS (New Const.)

f'c = 3,500 psi
 f'c = 4,000 psi (Superstructure)
 fy = 60,000 psi (Reinforcement)
 fy = 36,000 psi (M270 Grade 36)

FIELD UNITS (Exist. Const.)

f'c = 3,500 psi
 fy = 60,000 psi (Reinforcement)
 fs = 20,000 psi (Structural Steel 1988 Rehab)
 fs = 18,000 psi (Structural Steel 1959 Construction)

LOADING HS20-44 & ALT (New Const.)

no allowance for future wearing surface.

DESIGN SPECIFICATIONS

2002 AASHTO Standard Specifications for Highway Bridges, 17th Edition
 1995 FHWA Seismic Retrofitting Manual

SEISMIC DATA

Seismic Performance Category (SPC) = B
 Horizontal Bedrock Acceleration Coefficient (A) = 0.105g
 Site Coefficient (S) = 2.0

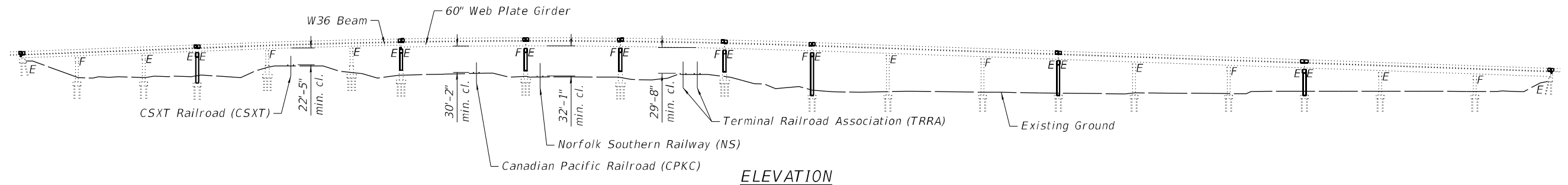

ELEVATION

See Sheets 4 and 5 of 114 for horizontal clearances.
 *Point of minimum vertical clearance
 **MP VC-2.84

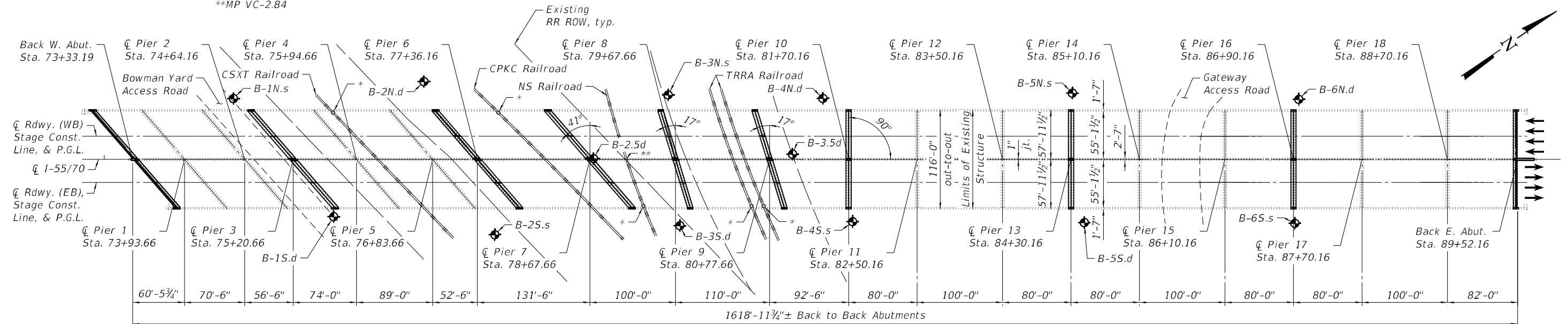

PLAN

SCOPE OF WORK

1. Partial and full depth concrete deck repairs.
2. Repairs to the parapets and replacement of the longitudinal joint between median barriers at centerline of structure.
3. Installation of new preformed joint strip seals at ten (10) piers, including removal and replacement of deck and parapet concrete each side of joint.
4. Installation of asphalt wearing surface with waterproofing system.
5. Replacement of cracked steel superstructure elements.
6. Steel superstructure section loss repairs.
7. Steel coating on fascia girders and at all girder ends under expansion joints as shown on plans.
8. Replacement of fixed and expansion bearings below expansion joints.
9. Seismic retrofit rehabilitation.
10. Removal and reconstruction of pier caps and all columns for Pier 3, 6, 13, & 16.
11. Removal and reconstruction of pier caps and innermost and outermost columns for Pier 7 thru 10.
12. Repairs to abutments and concrete pier caps, columns, and crash walls for all piers that are not reconstructed.
13. Drainage System Repair at Pier 9.



Signed: *Alex C. Benz*
 Date: 8/13/2024
 License Expires: 11/30/2024

The seal shown above is valid for the following sheets in these plans which were prepared under my direct supervision: Sheets 1-8, 29, 38-67, & 104-114 of 114.



Signed: *Richard A. Walther*
 Date: 8/13/2024
 License Expires: 11/30/2024

The seal shown above is valid for the following sheets in these plans which were prepared under my direct supervision: Sheets 9-28, 30-37, & 68-103 of 114.

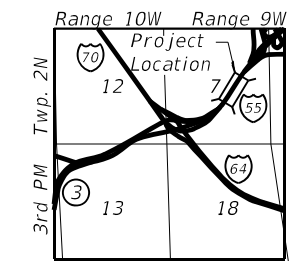

LOCATION SKETCH

GENERAL PLAN & ELEVATION
F.A.I. 70 (I-55/I-64/US 40)
OVER CSXT, CPKC, NS, & TRRA
SEC. 82-5VB-R-2
ST. CLAIR COUNTY
STATION 81+42.68
STRUCTURE NO. 082-0017

MODEL: Default
 FILE NAME: Z:\15052229 B&O RR Bridge\DN\Bridg\final\Plotsheets\0820017-76K02-001-GPE.dgn

EFK•Moen
 Civil Engineering Design

USER NAME = khll	DESIGNED - ACB	REVISIONS -
PLOT SCALE = 0.1667"/in.	CHECKED - CDL	REVISIONS -
PLOT DATE = 8/13/2024	DRAWN - ACB	REVISIONS -
	CHECKED - CDL	REVISIONS -

STATE OF ILLINOIS
DEPARTMENT OF TRANSPORTATION

GENERAL PLAN AND ELEVATION
STRUCTURE NO. 082-0017

SHEET 1 OF 114 SHEETS

F.A.I. RTE.	SECTION	COUNTY	TOTAL SHEETS	SHEET NO.
55/70	82-5VB-R-2	ST. CLAIR	254	139
CONTRACT NO. 76K02				

ILLINOIS FED. AID PROJECT

GENERAL NOTES

- Fasteners shall be ASTM A325, Type 1, mechanically galvanized bolts in painted areas and ASTM A325 Type 3 in unpainted areas. Bolts 7/8 in. Ø, holes 15/16 in. Ø, unless noted otherwise.
- All structural steel shall be AASHTO M 270 Grade 36, unless noted otherwise.
- No field welding is permitted except as specified in the contract documents. All specified welding shall utilize E70 electrodes.
- Reinforcing bars designated (E) shall be epoxy-coated.
- Prior to pouring the new concrete deck, all heavy or loose rust, loose mill scale, and other loose or potentially detrimental foreign material shall be removed from the surfaces in contact with concrete. Tightly adhered paint may remain unless otherwise noted. Removal shall be accomplished by methods that will not damage the steel and the cost will be included in the pay item covering removal of the existing concrete.
- As directed by the Engineer, existing construction accessories welded to the top flange of beams and girders shall be removed. The weld areas shall be ground flush and inspected for cracks using magnetic particle testing (MT) or dye penetrant testing (PT) by qualified personnel approved by the Engineer. Any cracks that cannot be removed by grinding ¼ inch deep shall be identified and reported to the Bureau of Bridges and Structures for further disposition. The cost of removing welded accessories, grinding and inspecting weld areas and grinding cracks will be paid for according to Article 109.04 of the Standard Specifications.
- If the Contractor elects to use cantilever forming brackets on the exterior beams or girders, the brackets shall be placed at the same locations as required for the hardwood blocks in Article 503.06(b) of the Standard Specifications. If additional cantilever forming brackets are required, hardwood blocking shall be wedged between the exterior and first interior beam at each of these additional bracket locations.
- Plan dimensions and details relative to existing plans are subject to nominal construction variations. The Contractor shall field verify existing dimensions and details affecting new construction and make necessary approved adjustments prior to construction or ordering of materials. Such variations shall not be cause for additional compensation for a change in scope of the work, however, the Contractor will be paid for the quantity actually furnished at the unit price bid for the work.
- The Contractor shall exercise extreme caution with demolition activities to prevent damage to the existing structure. Any damage from the construction activities shall be repaired at the Contractor's expense.
- The Contractor shall field verify all proposed structural plate, angle, and member dimensions and spacing of holes prior to ordering steel.
- Bearing seat surfaces shall be constructed or adjusted to the designated elevations within a tolerance of 1/8 in. Adjustments shall be made either by grinding the surface or by shimming the bearings.
- Concrete Sealer shall be applied to the designated areas of the piers.
- The existing structural steel coating contains lead. The Contractor shall take appropriate precautions to deal with the presence of lead on this project.
- Existing structural steel that will be in contact with new structural steel shall be cleaned and painted prior to erection as required by the Special Provision, "Cleaning and Painting Existing Steel Structures".
- All new structural steel to remain (exclusive of temporary works for the shoring and pier replacement) shall be hot-dipped galvanized. See Special Provisions for "Hot Dip Galvanizing of Structural Steel".

GENERAL NOTES (Continued)

- The Contractor shall make allowance for the deflection of forms, shrinkage and settlement of false work, in addition to allowance for dead load deflection.
- The Contractor shall grind all cracked welds parallel to the direction of the existing weld and not perpendicular to the weld.
- Refer to "76K02-Excerpts from Existing Structural Steel Drawings" on the contract letting site for additional information related to the existing conditions undergoing rehabilitation.

INDEX OF SHEETS

- General Plan and Elevation
- General Data
- General Data
- Partial Plan and Elevation at Railroads
- Partial Plan and Elevation at Railroads
- Shoring Schematics
- Stage Construction Details
- Temporary Concrete Barrier
- Deck Slab Repair (Spans 1-3)
- Deck Slab Repair (Spans 4-6)
- Deck Slab Repair (Spans 7-8)
- Deck Slab Repair (Spans 9-10)
- Deck Slab Repair (Spans 11-13)
- Deck Slab Repair (Spans 14-16)
- Deck Slab Repair (Spans 17-19)
- Deck Cross Section
- Concrete Repair Details
- Expansion Joint Removal Details (Abutments)
- Expansion Joint Removal Details (Piers)
- Expansion Joint Replacement Details (West Abutment)
- Expansion Joint Replacement Details (West Abutment)
- Expansion Joint Replacement Details (Pier 3, 6, & 7)
- Expansion Joint Replacement Details (Pier 8 & 9)
- Expansion Joint Replacement Details (Pier 10, 13, & 16)
- Expansion Joint Replacement Details (East Abutment)
- Expansion Joint Replacement Details (East Abutment)
- Preformed Joint Strip Seal
- Longitudinal Joint Details
- Drainage Scupper Adjustment Details
- Framing Plan and Repair Locations
- Framing Plan and Repair Locations
- Framing Plan and Repair Locations
- Diaphragm and Cross Frame Repair
- Bearing Details - Type I
- Bearing Stiffener Repairs
- Girder and Drainage System Repairs
- Limits of Steel Coating and Coating Details
- Substructure Removal (Pier 3)
- Substructure Removal (Pier 6)
- Substructure Removal (Pier 7)
- Substructure Removal (Pier 8)
- Substructure Removal (Pier 9)
- Substructure Removal (Pier 10)
- Substructure Removal (Pier 13)
- Substructure Removal (Pier 16)
- Substructure Replacement (Pier 3 WB)
- Substructure Replacement (Pier 3 WB)
- Substructure Replacement (Pier 3 EB)
- Substructure Replacement (Pier 3 EB)
- Substructure Replacement (Pier 6 WB)
- Substructure Replacement (Pier 6 WB)
- Substructure Replacement (Pier 6 EB)
- Substructure Replacement (Pier 6 EB)
- Substructure Replacement (Pier 7 WB)
- Substructure Replacement (Pier 7 WB)
- Substructure Replacement (Pier 7 EB)
- Substructure Replacement (Pier 7 EB)

INDEX OF SHEETS (Continued)

- Substructure Replacement (Pier 8 WB)
- Substructure Replacement (Pier 8 EB)
- Substructure Replacement (Pier 9 WB)
- Substructure Replacement (Pier 9 EB)
- Substructure Replacement (Pier 10 WB)
- Substructure Replacement (Pier 10 EB)
- Substructure Replacement (Pier 13 WB)
- Substructure Replacement (Pier 13 EB)
- Substructure Replacement (Pier 16 WB)
- Substructure Replacement (Pier 16 EB)
- West Abutment Repair Details
- East Abutment Repair Details
- Pier 1 Repair Details
- Pier 2 Repair Details
- Pier 4 Repair Details
- Pier 5 Repair Details
- Pier 6 Repair Details
- Pier 7 Repair Details
- Pier 8 Repair Details
- Pier 9 Repair Details
- Pier 10 Repair Details
- Pier 11 Repair Details
- Pier 12 Repair Details
- Pier 14 Repair Details
- Pier 15 Repair Details
- Pier 17 Repair Details
- Pier 18 Repair Details
- Plan View of Shoring Near Railroads
- Typical Shoring Tower Plans
- Micropile Details and Notes
- Pier 6 Details for Shoring Design
- Pier 7 Details for Shoring Design
- Pier 8 Details for Shoring Design
- Pier 9 Details for Shoring Design
- Shoring Tower Details
- Typical Shoring Tower Foundation Details
- Pier 7 Strongback Shoring Tower Foundation Details
- Alternate Shoring Tower Foundation Details
- Prop Shoring Tower Foundation Details
- Partial Plan - Span 7 and 8 EB
- Pier 7 - Elevation View (Beam J)
- Pier 7 - Elevation View (Beam R)
- Pier 7 EB - Partial Framing Plan (Girders J-R)
- Pier 7 EB - Strongback Beam Details 1
- Pier 7 EB - Strongback Beam Details 2
- Pier 7 EB - Strongback Beam Details 3
- Pier 9 Drainage Repair
- Bar Splicer Assembly and Mechanical Splicer Details
- Soil Boring Logs
- Soil Boring Logs
- Soil Boring Logs
- Soil Boring Logs
- Soil Boring Logs
- Soil Boring Logs
- Soil Boring Logs
- Soil Boring Logs
- Soil Boring Logs

TOTAL BILL OF MATERIAL

ITEM	UNIT	SUPER	SUB	TOTAL
Polymerized Hot-Mix Asphalt Surface Course, Stone Matrix Asphalt 9.5, Mix "E", N80	Ton	1,661		1,661
Welded Wire Reinforcement	Sq. Yd.	758		758
Concrete Removal	Cu. Yd.	267.2		267.2
Protective Shield	Sq. Yd.	1,914		1,914
Concrete Structures	Cu. Yd.		1,649.8	1,649.8
Concrete Superstructure	Cu. Yd.	309.2		309.2
Reinforcement Bars, Epoxy Coated	Pound	40,120	277,420	317,540
Bar Splicers	Each	484	60	544
Preformed Joint Seal 2 1/4"	Foot	1,655		1,655
Preformed Joint Strip Seal	Foot	1,296		1,296
Furnishing and Erecting Structural Steel	Pound	12,600		12,600
Elastomeric Bearing Assembly, Type I	Each	192		192
Anchor Bolts, 1 1/2"	Each	512		512
Concrete Sealer	Sq. Ft.		36,774	36,774
Concrete Glare Screen	Foot	356		356
Conduit Support System	L Sum	1		1
Bolt Replacement	Each	307		307
Polyurethane Sealant	Foot	3,002		3,002
Full Lane Sealant Waterproofing System	Sq. Yd.	19,777		19,777
Concrete Removal (Special)	Cu. Yd.		1,030.6	1,030.6
Protective Coat (Special)	Sq. Yd.		68	68
Structural Steel Repair	Pound	59,170		59,170
Bridge Drainage System Repair	Each		1	1
Containment and Disposal of Lead Paint Cleaning Residues No. 1	L. Sum	1		1
Cleaning and Painting Steel Bridge No. 1	L. Sum	1		1
Cleaning Drainage System	L. Sum	1		1
Structural Repair of Concrete (depth equal to or less than 5 inches)	Sq. Ft.	977	7,184	8,161
Structural Repair of Concrete (depth greater than 5 inches)	Sq. Ft.	109	806	915
Deck Slab Repair (Full Depth, Type I)	Sq. Yd.	52		52
Deck Slab Repair (Full Depth, Type II)	Sq. Yd.	52		52
Deck Slab Repair (Partial)	Sq. Yd.	496		496
Drainage Scuppers to be Adjusted	Each	26		26
Temporary Support System, Location 1	Each		1	1
Temporary Support System, Location 2	Each		1	1
Temporary Support System, Location 3	Each		1	1
Temporary Support System, Location 4	Each		1	1
Temporary Support System, Location 5	Each		1	1
Temporary Support System, Location 6	Each		1	1
Temporary Support System, Location 7	Each		1	1
Temporary Support System, Location 8	Each		1	1

MODEL: Default
FILE NAME: Z:\1505229_B&O RR Bridge\DNV\Bridg\final\Plotsheets\0820017-76K02-002-General_Data.dgn

EFK Moen Civil Engineering Design	USER NAME = khill	DESIGNED - ACB	REVISED -
		CHECKED - CDL	REVISED -
	PLOT SCALE = 0.1667"/in.	DRAWN - ACB	REVISED -
	PLOT DATE = 8/13/2024	CHECKED - CDL	REVISED -

**STATE OF ILLINOIS
DEPARTMENT OF TRANSPORTATION**

**GENERAL DATA
STRUCTURE NO. 082-0017**

SHEET 2 OF 114 SHEETS

F.A.I. RTE.	SECTION	COUNTY	TOTAL SHEETS	SHEET NO.
5570	82-5VB-R-2	ST. CLAIR	254	140
CONTRACT NO. 76K02				
ILLINOIS		FED. AID PROJECT		

STEEL COATING NOTES

- The structure was last painted in 1988 and the steel coatings are known to contain lead.
- Cleaning and painting of the existing structural steel shall be as specified in the special provision for "Cleaning and Painting Existing Steel Structures". Refer to Sheet 37 for paint limits and additional details.
- Complete paint system shall be applied to fascia and median girders.
- All beams, bearings, and other structural steel within 10 ft (measured along the beam) on either side of deck joints shall be cleaned per Near White Blast Cleaning (SSPC-SP10).
- The designated areas cleaned per Near White Blast Cleaning (SSPC-SP10) shall be painted according to the requirements of Organic Zinc-Rich Primer/Epoxy Intermediate Coat/Urethane Topcoat (OZ/E/U) paint system. The color of the final finish coat for all interior steel surfaces shall be Gray, Munsell No. 5B 7/1. The color of the final finish coat for the exterior and bottom flange of the fascia beams shall be Interstate Green, Munsell No. 7.5G 4/8.
- The Contractor shall submit calculations and details demonstrating the structural integrity of the bridge is maintained under the additional imposed loads of the containment system. See special provision "Structural Assessment Reports for Contractor's Means and Methods".
- A minimum of 2 air monitors will be required to monitor abrasive blasting operations at this site. See special provision for "Containment and Disposal of Lead Paint Cleaning Residues".
- SSPC QP1 (and SSPC QP2) Certification is required for this Contract.

STEEL REPAIR NOTES

- Steel repair locations as shown on Sheet 30 thru 32 are based on inspection data from 2020 and 2021.
- Allow Engineer time to perform an inspection of the structure prior to commencement of steel repair work, to locate additional repairs.
- The exact locations and nature of repairs shall be determined by the Engineer. The Engineer shall show actual repair locations on as-built plans.
- Repairs not shown on these plans, but indicated by the Engineer, shall be completed in accordance with the details in these Contract Drawings and per the Project Specifications, or as directed by the Engineer.

CONCRETE REPAIR NOTES

- Concrete deck and substructure repair areas as shown in the drawings are based on inspection data from June 2020.
- It is expected that actual repair areas may be different in shape, size, and location than shown on the drawings. The exact locations shall be determined by the Engineer. The Engineer shall show actual repair areas and their dimensions on as-built plans.
- Only partial depth deck repairs are anticipated at locations away from joints; however, a nominal quantity of both Deck Slab Repair (Full Depth - Type I) and Deck Slab Repair (Full Depth - Type II) is included in the total bill of materials to account for some repair areas shown on the plans extending through more than half of the deck cross section. Actual depth of repairs to be verified by the Engineer.
- For partial depth superstructure and substructure repairs, saw cut perimeter of repair area and remove all unsound concrete and sufficient sound concrete to create minimum gaps around reinforcing bars.

CONCRETE REPAIR NOTES (CONTINUED)

- For full depth deck repairs near joints, saw cut perimeter of repair area and remove all concrete 3 ft from each side of the joint. Extreme caution shall be exercised while removing concrete adjacent to beams. Any damage to beams shall be repaired at the Contractor's expense. Removal of existing expansion joints shall be included in the cost of Concrete Removal.
- Any reinforcing bars damaged during concrete removal shall be repaired or replaced using an approved bar splicer or anchorage system. Cost included with Concrete Removal.
- The Contractor shall take all measures necessary to ensure that no debris or other construction materials or equipment infringe on the railroad construction envelope, per Railroad General Notes (see Roadway Plans). Refer to Railroad Requirements for work which will require coordination.
- Existing reinforcing bars shall be field-coated with epoxy, in accordance with the Special Provision "Cleaning and Painting of Existing Reinforcing Bars".
- New concrete deck surfaces adjacent to expansion joints and at horizontal surface patches shall have a tined finish as per Article 420.09(e)(1) of the Standard Specifications. Cost included with Deck Slab Repair or Concrete Superstructure.
- At locations where the roadway will be open to traffic within two weeks or less of concrete placement due to construction staging, an accelerating admixture from the IDOT Qualified Product List of Concrete Admixtures shall be used for concrete superstructure and deck slab repairs. Refer to the Roadway Plans and project schedule.
- Only Structural Repair of Concrete (depth less than or equal to 5 inches) is anticipated. A nominal quantity of Structural Repair of Concrete (depth greater than 5 inches) is included in the total bill of materials to account for some repair areas shown on the plans extending deeper than 5 inches. This quantity applies to vertical repairs to the parapets (superstructure) or local, vertical repairs to the substructure. Actual depth of repairs to be verified by the Engineer.
- Use of shotcrete is not permitted.
- See special provisions for "Structural Repair of Concrete", "Concrete Glare Screen", and "Deck Slab Repair" for additional requirements.

TEMPORARY SUPPORT SYSTEM NOTES

- Contractor is responsible for design and erection of temporary shoring required for substructure rehabilitation (pier reconstruction, either partial or full-replacement) for piers 3, 10, 13, & 16. Structural details shall be prepared, signed and sealed by a Structural Engineer licensed in the State of Illinois, and shall be submitted to the Engineer for review prior to construction. The design of the temporary shoring for piers 6 through 9 are included within these plans on Sheets 85 thru 103 of 114.
- The Contractor is responsible for meeting all requirements of the GBSPs as related to construction and proof testing of foundations to support temporary shoring systems.
- Schematic shoring details and shoring loads are provided on Sheet 6 of 114.
- For reference, results from 2021 soils investigation are provided in the "76K02 - Geotechnical Design Memorandum", available on the Contract Letting site or upon request.
- Supplemental web stiffeners shall be installed on the existing girders at the strongback hanger locations and shoring tower locations even if locations coincide with existing web stiffeners. Reference Sheet 101 & 102 of 114 for additional information on supplemental stiffeners.
- As noted on Sheet 100 of 114, steel superstructure repairs in Spans 7 and 8 shall be performed prior to temporary shoring operations.

TEMPORARY SUPPORT SYSTEM NOTES (CONTINUED)

- The bridge shall be brought to its original elevation and profile after substructure repairs and bearing replacements have been completed.
- Design and usage of Temporary Support System is specific to this Contract. After the Temporary Support System is no longer required, it shall be fully removed and become the property of the Contractor. All concrete bearing pads shall be removed, micropiles and deep foundations excavated to at least 3 ft below original grade, and the ground line at all locations, except Pier 9, shall be returned to its original condition once the temporary shoring is removed.
- Work at Pier 7 EB and Pier 9 EB require staging (see Sheet 85 of 114). Work at Pier 9 will require coordination with Bridge Drainage System Repair (see Sheet 104 of 114).

PROTECTIVE SHIELD NOTES

- Refer to Special Provision "Protective Shield" for additional requirements.
- Protective Shield, At-Grade Track Shield, and Debris Shield shall be considered as "Protective Shield".
- It is anticipated that all pier reconstruction work in the railroad zone will require Debris Shield (see Sheet 4 and 5 of 114).
- It is anticipated that work in Span 3 will be coordinated with IDOT such that road closures do not affect maintenance crews needing to access roadway below Span 3.
- It is anticipated that work in Span 15 will require a nominal quantity of Protective Shield during deck slab repairs (Sheet 14 of 114).

RAILROAD REQUIREMENTS

- Within these notes and unless otherwise specified, the four rail lines (TRRA, CSXT, NS, CPKC) may be referred to collectively as the "Railroad" and/or "Railroads".
- A contractor's right-of-entry permit is required before any work can commence on railroad property. The cost to obtain this permit shall be considered incidental to the project. Refer to Roadway Plans and Special Provisions for additional requirements.
- No work can commence on railroad property until the respective rubble management plans are approved by the railroads and until the At-Grade Track Protection is installed. Refer to Roadway Plans for additional requirements.
- The following rehabilitation tasks are anticipated to require coordination and railroad approval:
 - Local deck slab repairs between Pier 4 and Pier 9 - above all railroad tracks (Sheets 10 thru 12 of 114)
 - Joint repair work at Piers 6, 7, 8, and 9 - above CPKC, NS, and TRRA railroad tracks (Sheets 19, 22, & 23 of 114)
 - Steel coating between Pier 4 and Pier 9 - adjacent to all railroad tracks (Sheets 30 thru 31 of 114)
 - Steel superstructure repairs (include deck drainage repairs) between Pier 4 and Pier 9 - adjacent to all railroad tracks (Sheets 30 thru 31 of 114)
 - Local substructure concrete repairs at Pier 4 - adjacent to CSXT Railroad track (Sheet 72 of 114)
 - Substructure repairs and replacements of Pier 6, 7, 8, and 9 - adjacent to CPKC, NS, TRRA railroads tracks (Sheets 39 thru 42, 50 thru 61, and 74 thru 77 of 114)

MESD REQUIREMENTS

- In addition to the Railroad Requirements, subsurface work between Pier 9 and the East Abutment will require coordination with Metro East Sanitary District (MESD). A right of entry permit and approval will be required for all work related to the temporary shoring and substructure repairs. Refer to Roadway Plans and Special Provisions for more information.
- The drainage ditch between Pier 13 and 14 shall remain open.

MODEL: Default
FILE NAME: Z:\15052.29 B&O RR Bridge\DNV\Bridg\final\Plotsheets\0820017-76K02-003-General_Data.dgn

EFK Moen Civil Engineering Design	USER NAME = khill	DESIGNED - ACB	REVISED -
		CHECKED - CDL	REVISED -
	PLOT SCALE = 0.1667"/in.	DRAWN - ACB	REVISED -
	PLOT DATE = 8/13/2024	CHECKED - CDL	REVISED -

**STATE OF ILLINOIS
DEPARTMENT OF TRANSPORTATION**

**GENERAL DATA
STRUCTURE NO. 082-0017**

SHEET 3 OF 114 SHEETS

F.A.I. RTE.	SECTION	COUNTY	TOTAL SHEETS	SHEET NO.
55/70	82-5VB-R-2	ST. CLAIR	254	141
CONTRACT NO. 76K02				
ILLINOIS		FED. AID PROJECT		

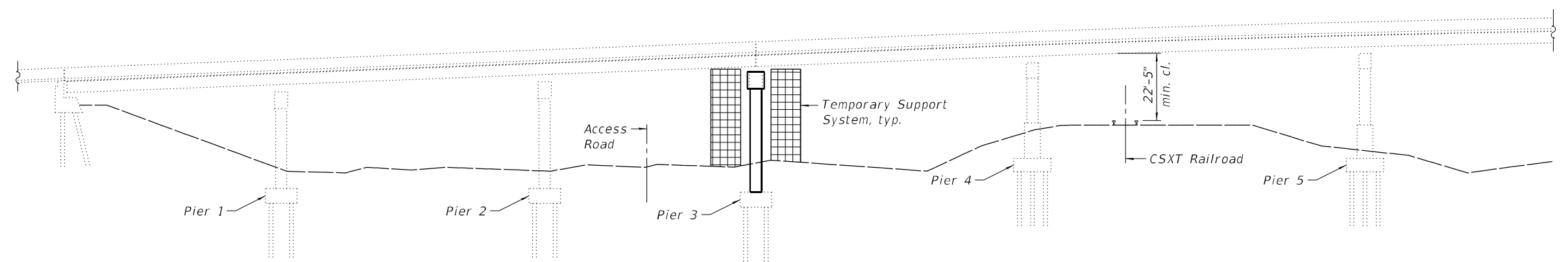

PARTIAL ELEVATION (SPANS 1 THRU 5)

Approximate Extent of Temporary Support System

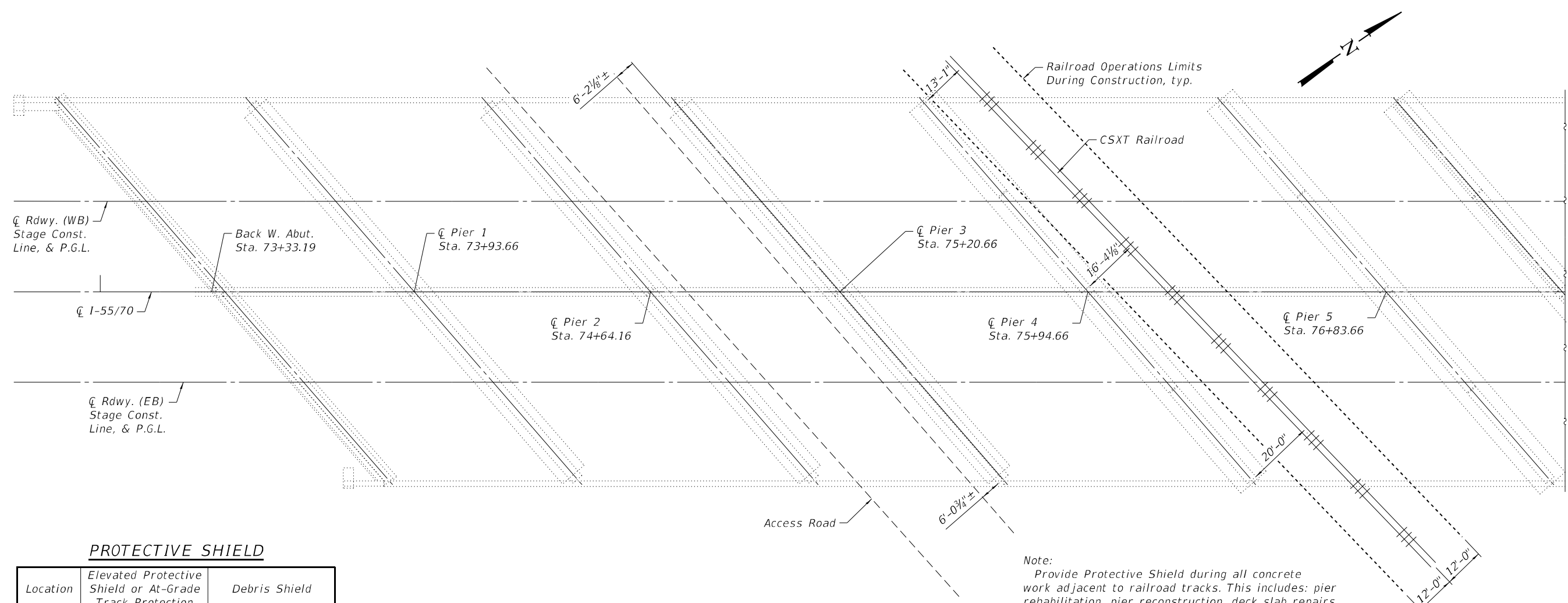

PARTIAL PLAN (SPANS 1 THRU 5)

PROTECTIVE SHIELD

Location	Elevated Protective Shield or At-Grade Track Protection (Sq. Yd.)	Debris Shield (Sq. Yd.)
Span 5	151	-
Span 7	-	544
Span 8	-	544
Span 9	-	650
Span 15	25	-

Note:
 Provide Protective Shield during all concrete work adjacent to railroad tracks. This includes: pier rehabilitation, pier reconstruction, deck slab repairs, and transverse expansion joint replacement. Refer to Special Provisions and Roadway plans for additional requirements.
 Provide Protective Shield in Span 15 (not shown) if full-depth repairs are required. See Sheet 14 of 114 for plan view with deck repair locations and additional information.
 All clearances apply to both existing and proposed construction.

BILL OF MATERIAL

Item	Unit	Total
Protective Shield	Sq. Yd.	1914

MODEL: Default
 FILE NAME: Z:\1505229_B&O_RR_Bridge\DCN\Bridg\final\Plotsheets\0820017-76K02-004-Shoring.dgn

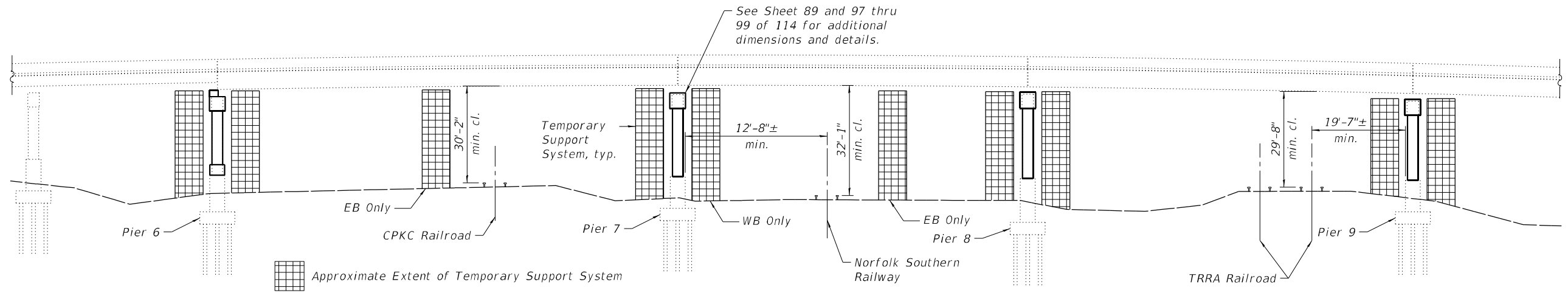

PARTIAL ELEVATION (SPANS 6 THRU 9)

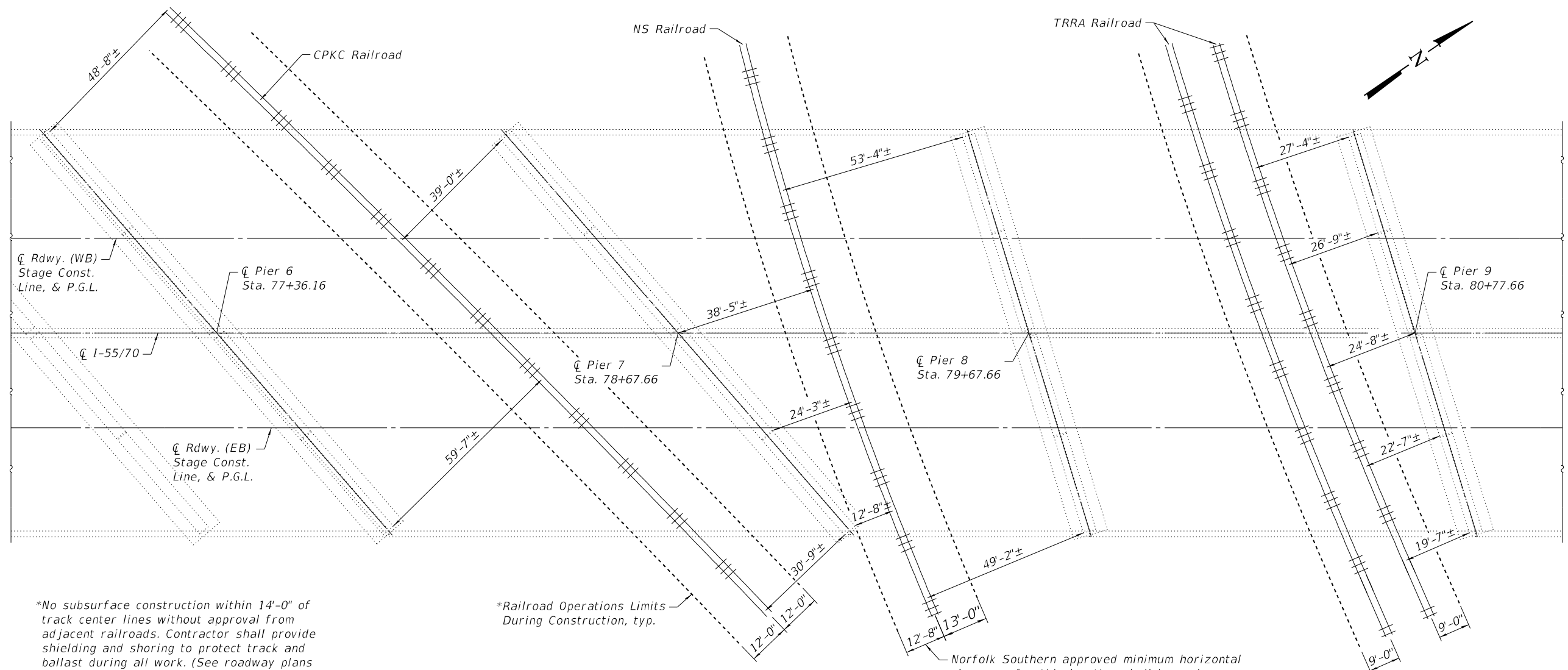

PARTIAL PLAN (SPANS 6 THRU 9)

*No subsurface construction within 14'-0" of track center lines without approval from adjacent railroads. Contractor shall provide shielding and shoring to protect track and ballast during all work. (See roadway plans for additional information)

*Railroad Operations Limits During Construction, typ.

Norfolk Southern approved minimum horizontal clearance for this location shall be no less than the existing 12'-8" clearance.

Note:
Eastbound Pier 7 reconstruction will be staged to reduce live loading on Temporary Support System. All clearances apply to both existing and proposed construction.

MODEL: Default
FILE NAME: Z:\1505229_B&O RR Bridge\DCN\Bridg\final\Plotsheets\0820017-76K02-005-Shoring.dgn

EFK Moen
Civil Engineering Design

USER NAME = khill	DESIGNED - ACB	REVISED -
	CHECKED - CDL	REVISED -
PLOT SCALE = 0.1667"/in.	DRAWN - ACB	REVISED -
PLOT DATE = 8/13/2024	CHECKED - CDL	REVISED -

**STATE OF ILLINOIS
DEPARTMENT OF TRANSPORTATION**

**PARTIAL PLAN AND ELEVATION AT RAILROADS
STRUCTURE NO. 082-0017**

SHEET 5 OF 114 SHEETS

F.A.I. RTE.	SECTION	COUNTY	TOTAL SHEETS	SHEET NO.
55/70	82-5VB-R-2	ST. CLAIR	254	143
CONTRACT NO. 76K02				
ILLINOIS		FED. AID PROJECT		

MODEL: Default
 FILE NAME: Z:\1505229 B&O RR Bridge\DN\Bridg\final\Plotsheets\0820017-76K02-006-Shoring_Schematics.dgn

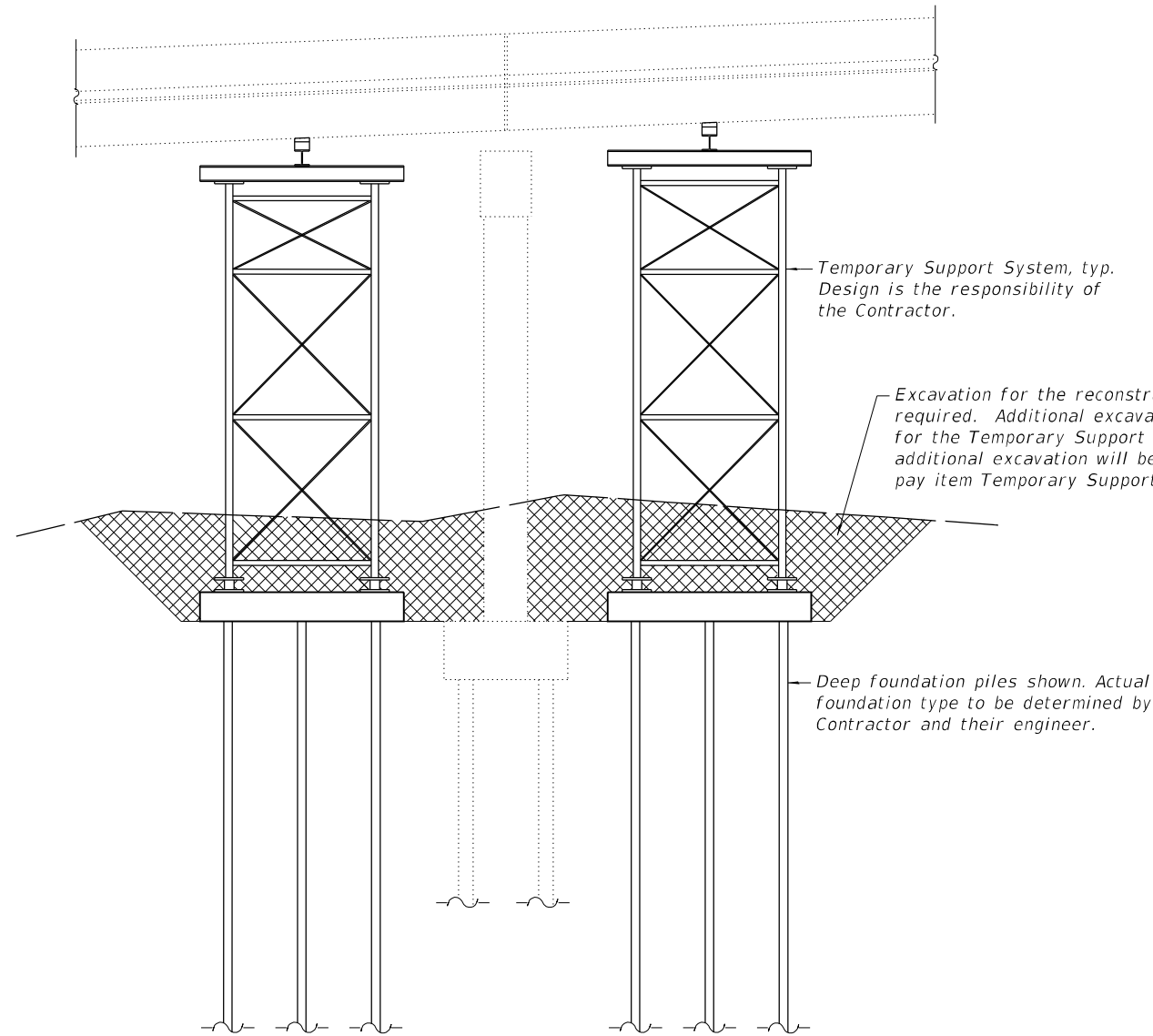

TEMPORARY SUPPORT SYSTEM
 (Piers 3, 10, 13, & 16)

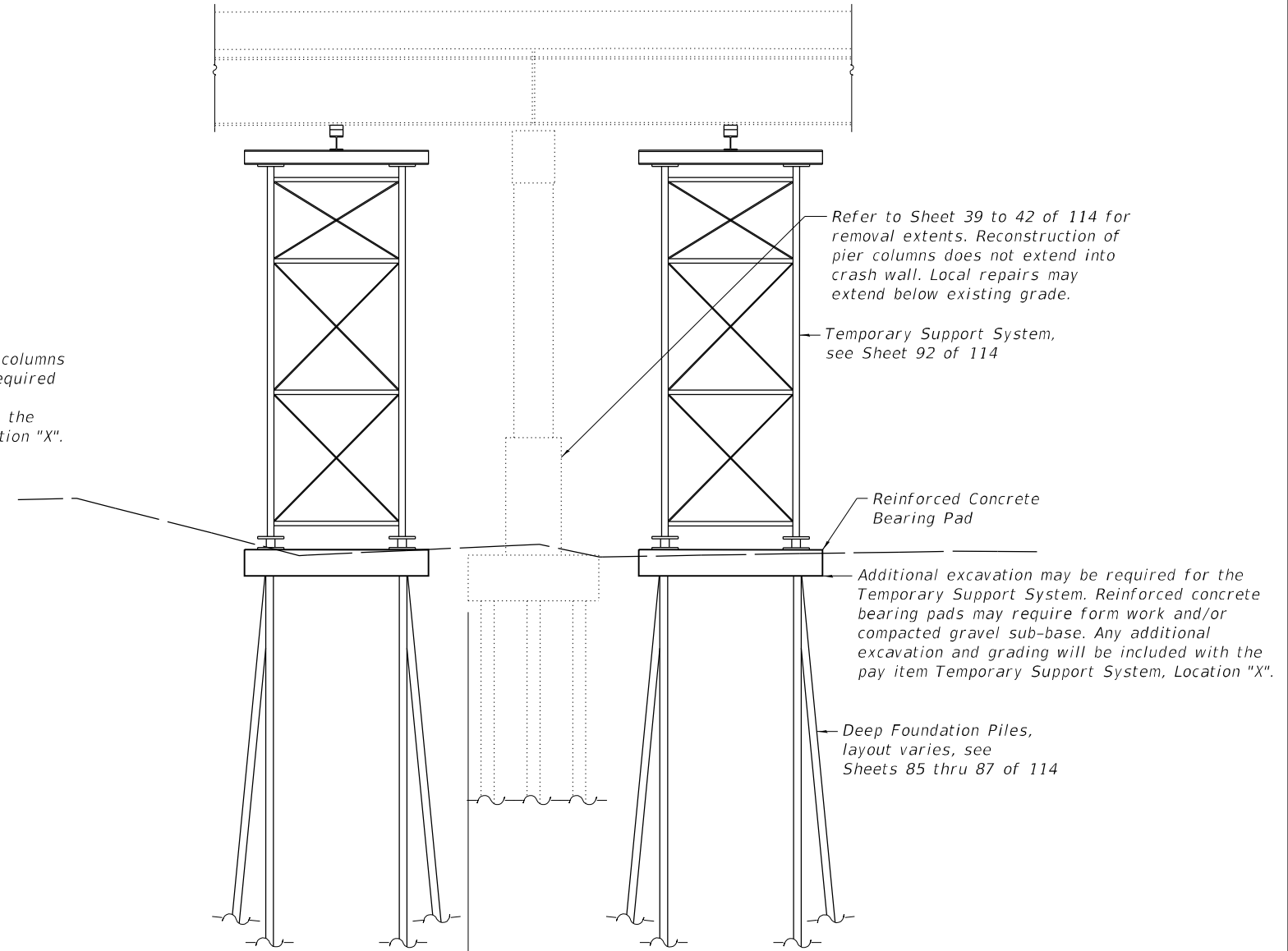

No micropiles within footprint of existing foundation elements. No micropiles within 5' of existing deep piles.

TEMPORARY SUPPORT SYSTEM
 (Piers 6, 7, 8, & 9)

DESIGN LOADING

1. Lateral Load: 20% of Dead Load
2. Vertical Load: Pier 7 Eastbound Replacement - Construction Live Loading of 75 PSF with HS-20 Outside of Shoring Zone
3. Vertical Load: Other Piers - AASHTO LFD Design Live Loading (HS-20)

Note:
 Contractor shall coordinate with railroads regarding whether excavation will require sheet piling.

Ground line shall be returned to its original condition (except Pier 9) after the temporary support system is removed.

Eastbound Pier 7 reconstruction shall be staged to reduce live loading on Temporary Support System.

Temporary Support System excavation depth is limited to the top of footing elevation of the adjacent pier. Excavation depths lower than the top of footing elevation of the adjacent pier will require sheet piling.

Temporary Support System for Piers 6 through 9 shall, at a minimum, include all Work shown on Sheets 85 thru 103 of 114.

Refer to Sheet 97 of 114 for reactions associated with Pier 7 - Eastbound.

TEMPORARY SUPPORT SYSTEM REACTION TABLE

Location	Service Reactions *															
	Pier 3		Pier 6		Pier 7**		Pier 8**		Pier 9		Pier 10		Pier 13		Pier 16	
	W. Brg.	E. Brg.	W. Brg.	E. Brg.	W. Brg.	E. Brg.	W. Brg.	E. Brg.	W. Brg.	E. Brg.	W. Brg.	E. Brg.	W. Brg.	E. Brg.	W. Brg.	E. Brg.
Dead Load (k)	25.9	35.1	20.7	98.5	103.0	89.8	93.3	70.3	70.3	68.5	68.5	36.9	36.9	36.9	36.9	36.9
Live Load (k)	46.2	45.3	43.6	51.5	51.2	51.4	47.2	46.5	47.5	47.7	46.3	42.9	42.9	42.9	42.9	42.9
Impact (k)	12.8	11.4	12.3	10.1	10.0	11.2	9.5	9.9	10.2	10.9	10.1	10.5	10.5	10.5	10.5	10.5
Total (k)	84.9	91.8	76.6	160.1	164.2	152.4	150.0	126.7	128.0	127.1	124.9	90.3	90.3	90.3	90.3	90.3
Min. Jack Capacity (k)	150	150	150	250	250	250	250	200	200	200	200	150	150	150	150	150

* Reactions shown represent the maximum reaction for a single beam.

** Reference Sheet 97-99 of 114 for temporary support locations and reactions for work at Pier 7 EB.

BILL OF MATERIAL

Location	Item	Unit	Total
Pier 3	Temporary Support System, Location 1	Each	1
Pier 6	Temporary Support System, Location 2	Each	1
Pier 7	Temporary Support System, Location 3	Each	1
Pier 8	Temporary Support System, Location 4	Each	1
Pier 9	Temporary Support System, Location 5	Each	1
Pier 10	Temporary Support System, Location 6	Each	1
Pier 13	Temporary Support System, Location 7	Each	1
Pier 16	Temporary Support System, Location 8	Each	1

EFK Moen Civil Engineering Design	USER NAME = khill	DESIGNED - ACB	REVISED -
	PLOT SCALE = 0.1667"/in.	CHECKED - CDL	REVISED -
	PLOT DATE = 8/13/2024	DRAWN - ACB	REVISED -
		CHECKED - CDL	REVISED -

STATE OF ILLINOIS
DEPARTMENT OF TRANSPORTATION

SHORING SCHEMATICS
STRUCTURE NO. 082-0017

SHEET 6 OF 114 SHEETS

F.A.I. RTE.	SECTION	COUNTY	TOTAL SHEETS	SHEET NO.
55/70	82-5VB-R-2	ST. CLAIR	254	144
CONTRACT NO. 76K02				
ILLINOIS		FED. AID PROJECT		

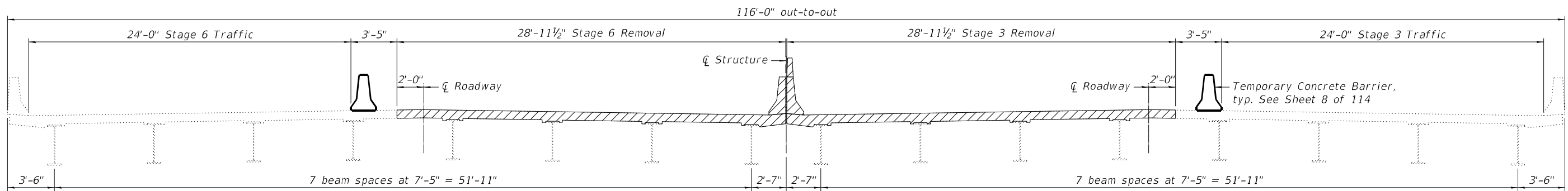

STAGE 3 & 6 REMOVAL
(Looking East)

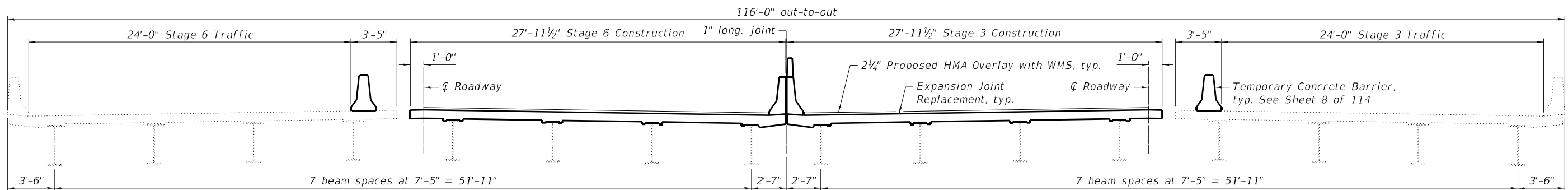

STAGE 3 & 6 CONSTRUCTION
(Looking East)

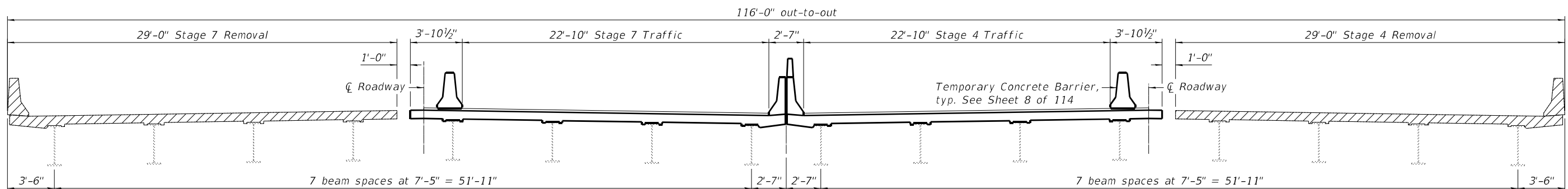

STAGE 4 & 7 REMOVAL
(Looking East)

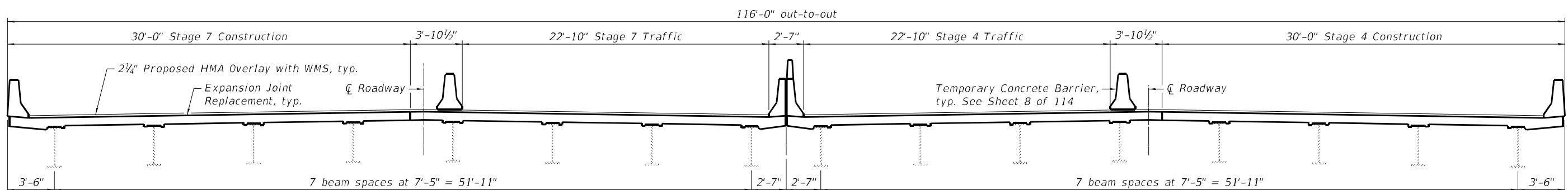

STAGE 4 & 7 CONSTRUCTION
(Looking East)

Notes:
Hatched area indicates Concrete Removal for expansion joint replacement. See Sheet 18 and 19 of 114.
For quantity of temporary concrete barrier, see Roadway Plans.
For details of HMA Overlay with WMS, see Sheet 16 of 114.

MODEL: Default
FILE NAME: Z:\1505229_B&O_RR_Bridge\DN\Bridges\0820017-76K02-007-5\Staged_Construction.dgn

USER NAME = khill	DESIGNED - ACB	REVISED -
PLOT SCALE = 0.1667"/in.	CHECKED - CDL	REVISED -
PLOT DATE = 8/13/2024	DRAWN - ACB	REVISED -
	CHECKED - CDL	REVISED -

F.A.I. RTE.	SECTION	COUNTY	TOTAL SHEETS	SHEET NO.
55/70	82-5VB-R-2	ST. CLAIR	254	145
CONTRACT NO. 76K02				
ILLINOIS		FED. AID PROJECT		

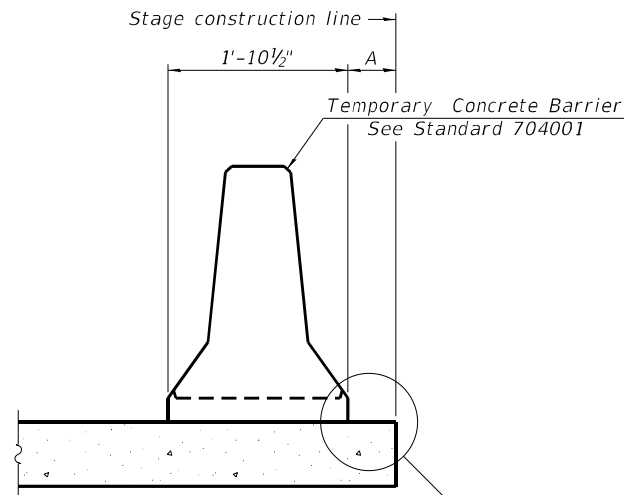

When "A" is 3'-1" or less, the temporary concrete barrier shall be restrained to the new slab according to Detail I, II or III. No restraint is required when "A" is greater than 3'-1".

NEW SLAB OR NEW DECK BEAM

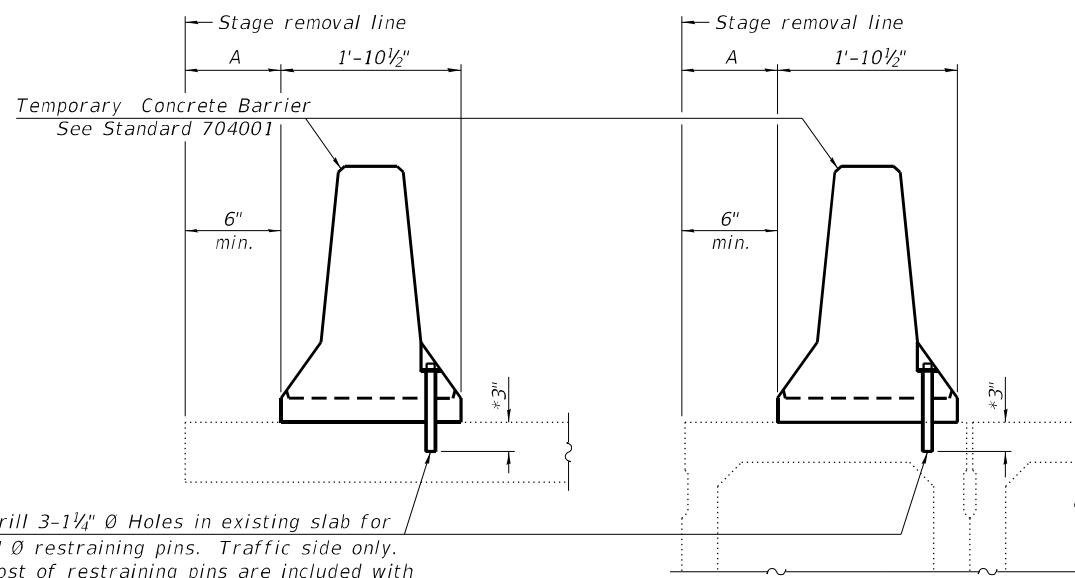

Drill 3-1/4" Ø Holes in existing slab for 1" Ø restraining pins. Traffic side only. Cost of restraining pins are included with Temporary Concrete Barrier. No restraint is required when "A" is greater than 3'-1".

EXISTING SLAB

* When hot-mix asphalt wearing surface is present, embedment shall be 3" plus the wearing surface depth.

EXISTING DECK BEAM

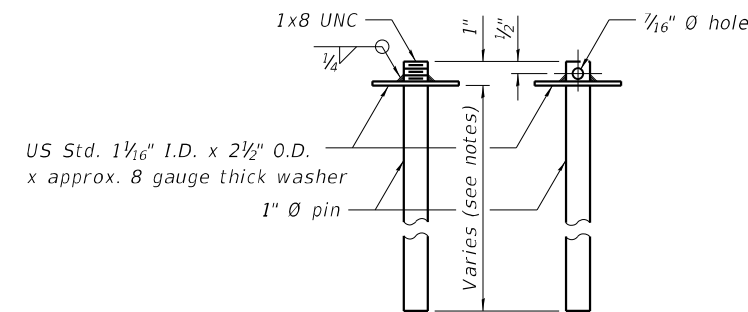

RESTRAINING PIN

SECTIONS THRU SLAB OR DECK BEAM

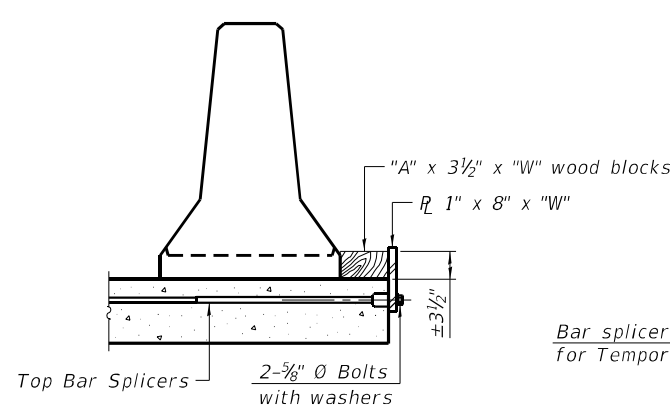

DETAIL I

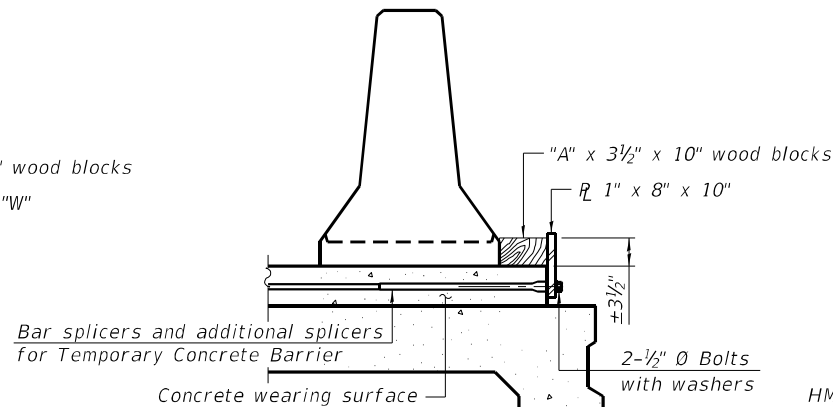

DETAIL II

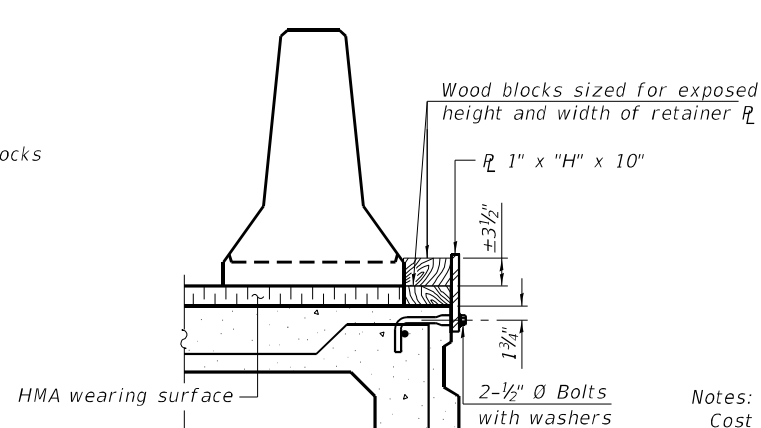

DETAIL III

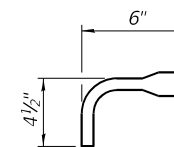

BAR SPLICER FOR #4 BAR - DETAIL III

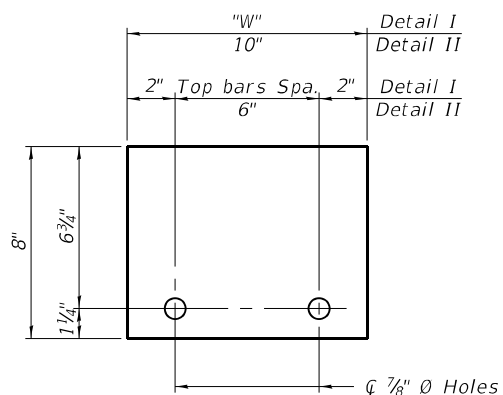

STEEL RETAINER R 1" x 8" x "W" (Detail I and II)

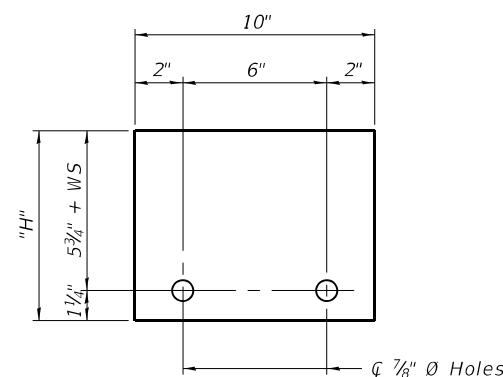

STEEL RETAINER R 1" x "H" x 10" (Detail III)

RAILING CRITERIA

NCHRP 350 Test Level	3
Railing Weight (plf)	440

R-27 10-12-2021

Notes:
 Cost of retainer assembly is included with Temporary Concrete Barrier.
 A retainer assembly shall be located at the approximate center of each temporary concrete barrier.
 The retainer plate shall not be removed until the concrete on the adjacent stage is ready to be poured. For Detail III applications the retainer plate shall not be removed until just prior to placing the adjacent beam.
 When the 'A' dimension is less than 1 1/2', the wood block shall be omitted and the barrier shall be placed in direct contact with the steel retainer plate. For deck beam applications the minimum required 'A' distance is 6" to accommodate the shear key clamping device.

Detail I - Installation for a new bridge deck or bridge slab.
 Detail II - Installation for a new deck beam with an initial concrete wearing surface. Additional bar splicers shall be provided at 6'-0" centers and paired with the bar splicers of the concrete wearing surface reinforcement to accommodate the installation of the retainer assemblies. The cost of the additional bar splicers is included with the concrete wearing surface.
 Detail III - Installation for a new deck beam with no initial wearing surface or with an initial hot-mix asphalt (HMA) wearing surface present. The deck beam directly beneath the temporary concrete barrier shall be fabricated with bar splicer inserts in the side of the beam, as detailed, to accommodate the installation of the retainer assemblies. A pair of bar splicers, 6" apart, shall be placed at 6'-0" centers along the length of the beam. The cost of the bar splicers is included with the deck beam.

MODEL: Default
 FILE NAME: Z:\15052229_B&O_RR_Bridge\DCN\Bridges\final\Plotsheets\0820017-76K02-008-Temporary_Concrete_Barrier.dgn

EFK Moen
 Civil Engineering Design

USER NAME = khll	DESIGNED - ACB	REVISED -
PLOT SCALE = 0.1667"/in.	CHECKED - CDL	REVISED -
PLOT DATE = 8/13/2024	DRAWN - ACB	REVISED -
	CHECKED - CDL	REVISED -

STATE OF ILLINOIS
 DEPARTMENT OF TRANSPORTATION

TEMPORARY CONCRETE BARRIER
 STRUCTURE NO. 082-0017

SHEET 8 OF 114 SHEETS

F.A.I. RTE.	SECTION	COUNTY	TOTAL SHEETS	SHEET NO.
55-70	82-5VB-R-2	ST. CLAIR	254	146
CONTRACT NO. 76K02				
ILLINOIS FED. AID PROJECT				

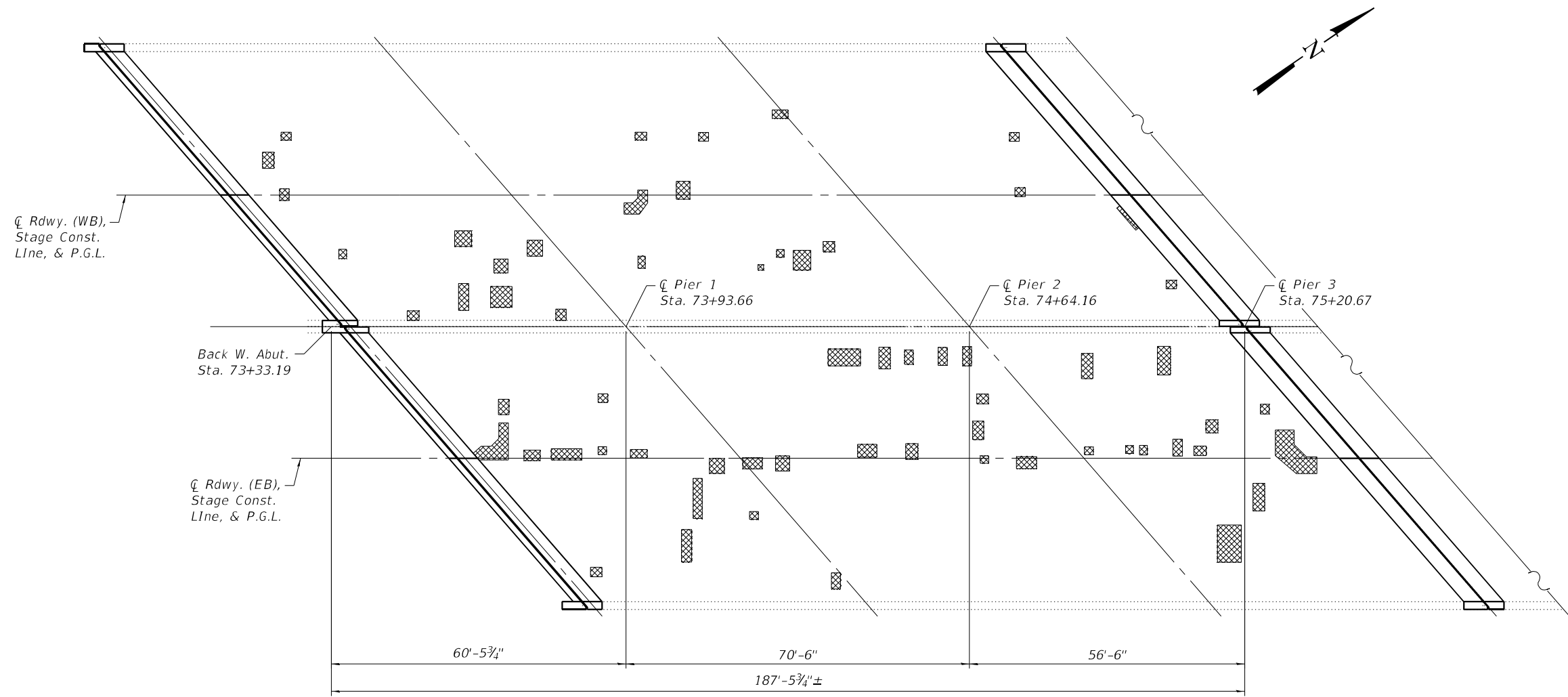

PLAN (SPANS 1 THRU 3)

 Deck Slab Repair (Partial)

Notes:
 Deck sounding was performed in June 2020, with quantities increased to account for anticipated growth.
 The Resident Engineer will determine final patch locations and quantities in the field before bridge deck patching operations begin.
 See Sheet 17 of 114 for details of full depth or partial depth patching.
 See Sheets 18 & 19 of 114 for details and quantities of removal of existing concrete each side of joint.
 See Sheets 20 thru 22 of 114 for details of replacement of concrete and new joints.

BRIDGE	PARTIAL DEPTH REPAIRS (Sq Yd)	FULL DEPTH REPAIRS (Sq Yd)	TOTAL (Sq Yd)
Westbound	22	6	28
Eastbound	48	8	56

BILL OF MATERIAL

Item	Unit	Total
Deck Slab Repair (Full Depth, Type I)	Sq. Yd.	7
Deck Slab Repair (Full Depth, Type II)	Sq. Yd.	7
Deck Slab Repair (Partial)	Sq. Yd.	70

MODEL: Default
 FILE NAME: Z:\1505229_B&O_RR_Bridge\DCN\Bridges\final\Plotsheets\0820017-76K02-009-Deck_Slab_Repair (Span 1-3).dgn

WJE ENGINEERS ARCHITECTS MATERIAL SCIENTISTS
 Wss, Janney, Elstner Associates, Inc.
 330 Pfingsten Road
 Northbrook, Illinois 60062
 847.272.7400 tel | 847.291.9595 fax
 www.wje.com

USER NAME = khill	DESIGNED - SMG	REVISED -
	CHECKED - RAW	REVISED -
PLOT SCALE = 0.1667"/in.	DRAWN - SMG	REVISED -
PLOT DATE = 8/13/2024	CHECKED - RAW	REVISED -

**STATE OF ILLINOIS
 DEPARTMENT OF TRANSPORTATION**

**DECK SLAB REPAIR (SPANS 1-3)
 STRUCTURE NO. 082-0017**

SHEET 9 OF 114 SHEETS

F.A.I. RTE.	SECTION	COUNTY	TOTAL SHEETS	SHEET NO.
55/70	82-5VB-R-2	ST. CLAIR	254	147
CONTRACT NO. 76K02				
ILLINOIS		FED. AID PROJECT		

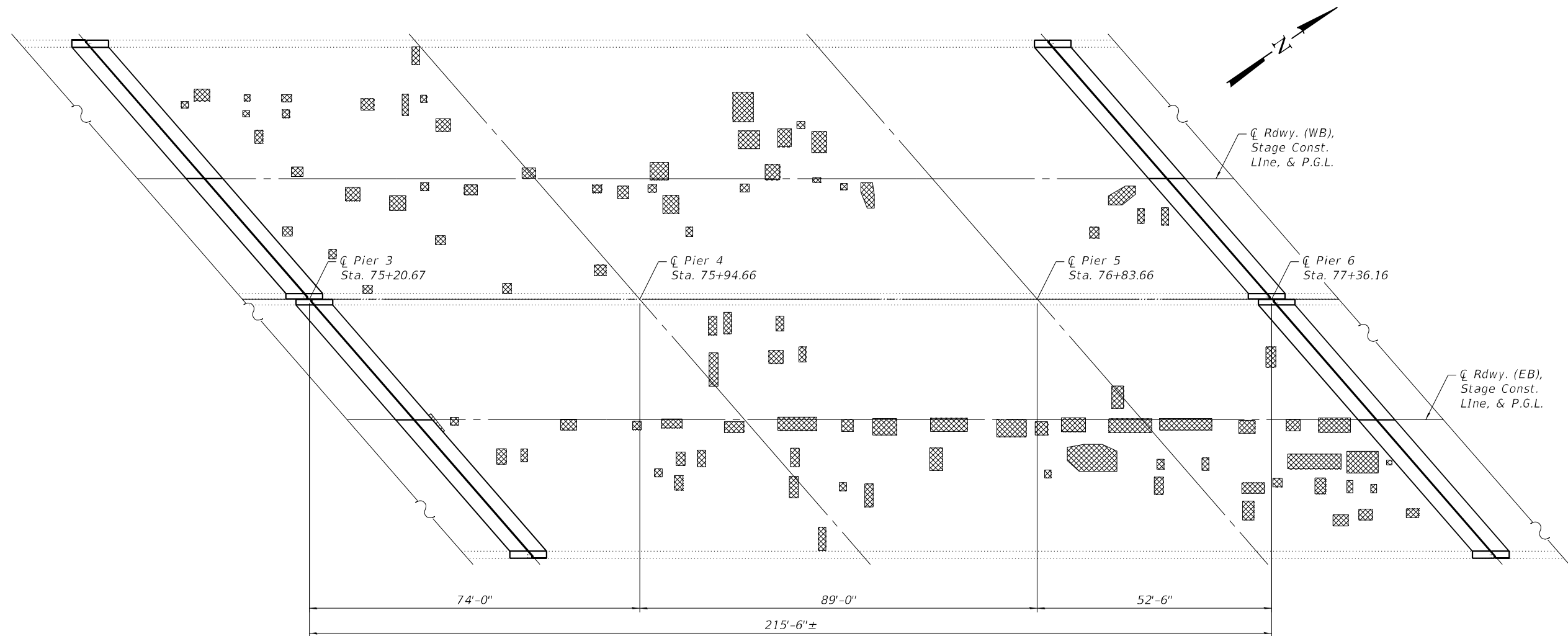

PLAN (SPANS 4 THRU 6)

Deck Slab Repair (Partial)

Notes:
 Deck sounding was performed in June 2020, with quantities increased to account for anticipated growth.
 The Resident Engineer will determine final patch locations and quantities in the field before bridge deck patching operations begin.
 See Sheet 17 of 114 for details of full depth or partial depth patching.
 See Sheet 19 of 114 for details and quantities of removal of existing concrete each side of joint.
 See Sheet 22 of 114 for details of replacement of concrete and new joints.

BRIDGE	PARTIAL DEPTH REPAIRS (Sq Yd)	FULL DEPTH REPAIRS (Sq Yd)	TOTAL (Sq Yd)
Westbound	41	8	49
Eastbound	80	12	92

BILL OF MATERIAL

Item	Unit	Total
Deck Slab Repair (Full Depth, Type I)	Sq. Yd.	10
Deck Slab Repair (Full Depth, Type II)	Sq. Yd.	10
Deck Slab Repair (Partial)	Sq. Yd.	121

MODEL: Default
 FILE NAME: Z:\15052.29_B&O_RR_Bridge\DCN\Bridges\10820017-76K02-010-Deck_Slab_Repair (Span 4-6).xdgn

WJE ENGINEERS ARCHITECTS MATERIAL SCIENTISTS
 Wss, Janney, Elstner Associates, Inc.
 330 Pfingsten Road
 Northbrook, Illinois 60062
 847.272.7400 tel | 847.291.9595 fax
 www.wje.com

USER NAME = khill	DESIGNED - SMG	REVISED -
	CHECKED - RAW	REVISED -
PLOT SCALE = 0.1667"/in.	DRAWN - SMG	REVISED -
PLOT DATE = 8/13/2024	CHECKED - RAW	REVISED -

**STATE OF ILLINOIS
 DEPARTMENT OF TRANSPORTATION**

**DECK SLAB REPAIR (SPANS 4-6)
 STRUCTURE NO. 082-0017**

SHEET 10 OF 114 SHEETS

F.A.I. RTE.	SECTION	COUNTY	TOTAL SHEETS	SHEET NO.
55/70	82-5VB-R-2	ST. CLAIR	254	148
CONTRACT NO. 76K02				
ILLINOIS		FED. AID PROJECT		

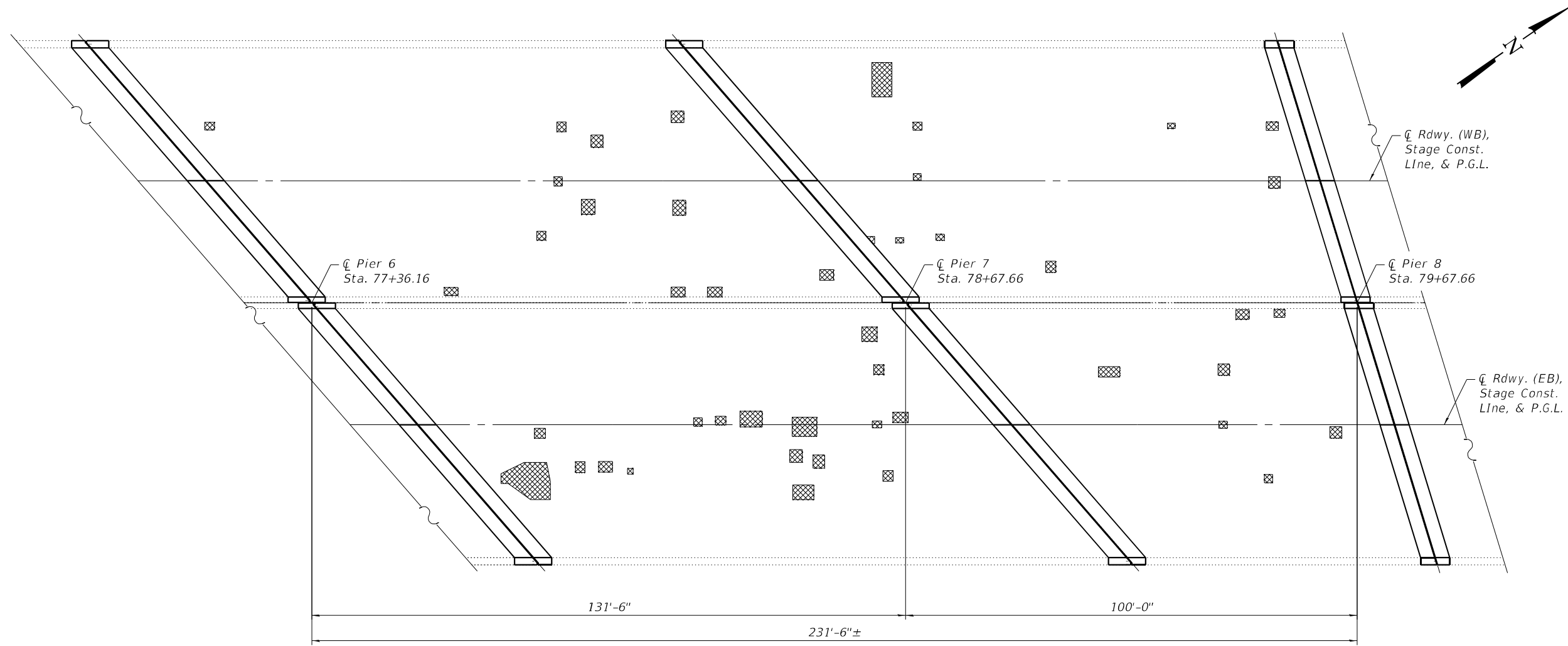

PLAN (SPANS 7 THRU 8)

Deck Slab Repair (Partial)

Notes:
 Deck sounding was performed in June 2020, with quantities increased to account for anticipated growth.
 The Resident Engineer will determine final patch locations and quantities in the field before bridge deck patching operations begin.
 See Sheet 17 of 114 for details of full depth or partial depth patching.
 See Sheet 19 of 114 for details and quantities of removal of existing concrete each side of joint.
 See Sheets 22 & 23 of 114 for details of replacement of concrete and new joints.

BRIDGE	PARTIAL DEPTH REPAIRS (Sq Yd)	FULL DEPTH REPAIRS (Sq Yd)	TOTAL (Sq Yd)
Westbound	19	4	23
Eastbound	29	6	35

BILL OF MATERIAL

Item	Unit	Total
Deck Slab Repair (Full Depth, Type I)	Sq. Yd.	5
Deck Slab Repair (Full Depth, Type II)	Sq. Yd.	5
Deck Slab Repair (Partial)	Sq. Yd.	48

MODEL: Default
 FILE NAME: Z:\15052.29_B&O_RR_Bridge\DCN\Bridges\final\Plotsheets\0820017-76K02-011-Deck_Slab_Repair (Span 7-8).xdgn

WJE ENGINEERS ARCHITECTS MATERIAL SCIENTISTS
 Wss, Janney, Elstner Associates, Inc.
 330 Pfingsten Road
 Northbrook, Illinois 60062
 847.272.7400 tel | 847.291.9595 fax
 www.wje.com

USER NAME = khill	DESIGNED - SMG	REVISED -
	CHECKED - RAW	REVISED -
PLOT SCALE = 0.1667" / in.	DRAWN - SMG	REVISED -
PLOT DATE = 8/13/2024	CHECKED - RAW	REVISED -

**STATE OF ILLINOIS
 DEPARTMENT OF TRANSPORTATION**

**DECK SLAB REPAIR (SPANS 7-8)
 STRUCTURE NO. 082-0017**

SHEET 11 OF 114 SHEETS

F.A.I. RTE.	SECTION	COUNTY	TOTAL SHEETS	SHEET NO.
55/70	82-5VB-R-2	ST. CLAIR	254	149
CONTRACT NO. 76K02				
		ILLINOIS	FED. AID PROJECT	

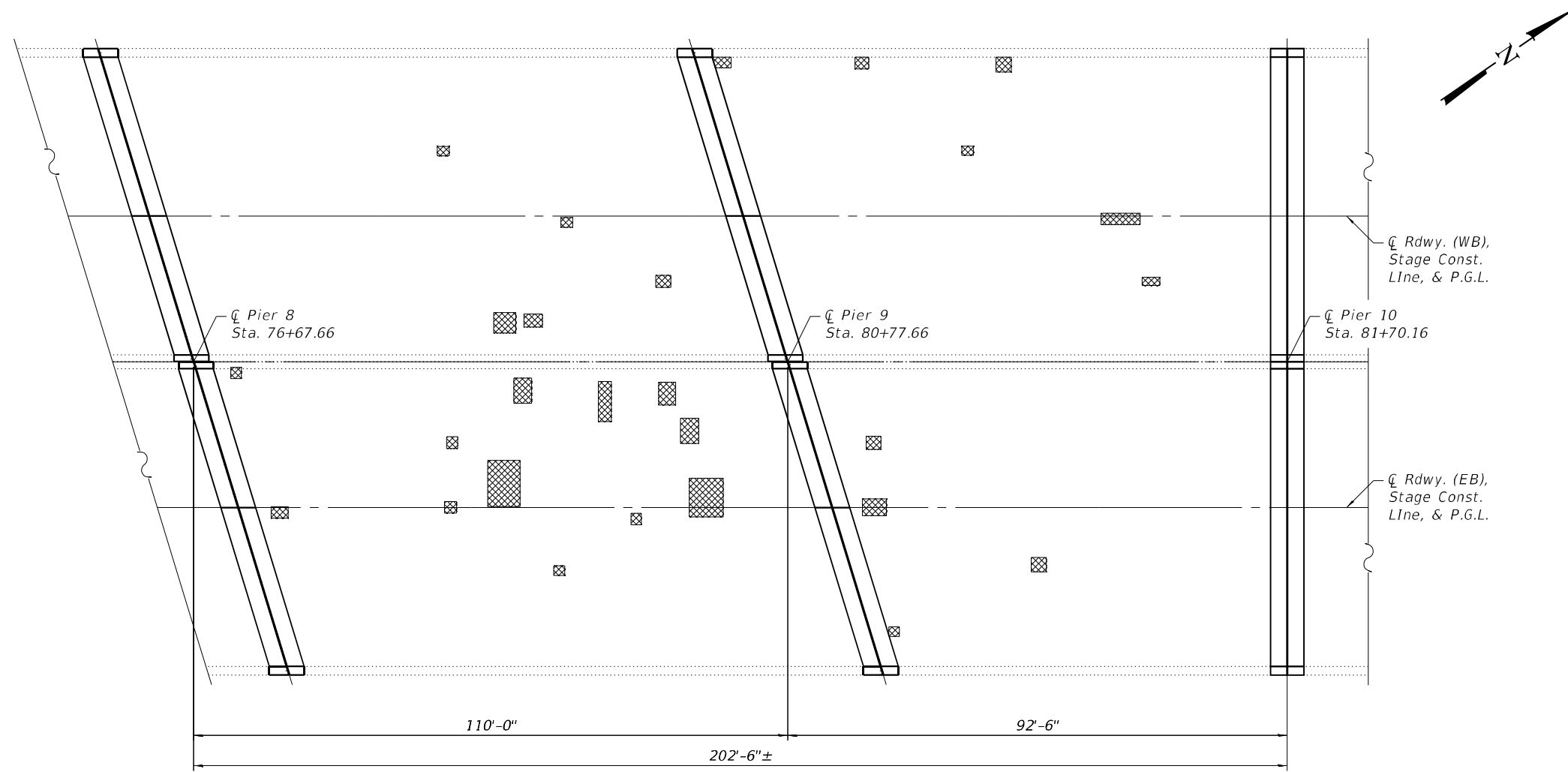

PLAN (SPANS 9 THRU 10)

Deck Slab Repair (Partial)

Notes:
 Deck sounding was performed in June 2020, with quantities increased to account for anticipated growth.
 The Resident Engineer will determine final patch locations and quantities in the field before bridge deck patching operations begin.
 See Sheet 17 of 114 for details of full depth or partial depth patching.
 See Sheet 19 of 114 for details and quantities of removal of existing concrete each side of joint.
 See Sheets 23 & 24 of 114 for details of replacement of concrete and new joints.

BRIDGE	PARTIAL DEPTH REPAIRS (Sq Yd)	FULL DEPTH REPAIRS (Sq Yd)	TOTAL (Sq Yd)
Westbound	11	4	15
Eastbound	27	6	33

BILL OF MATERIAL

Item	Unit	Total
Deck Slab Repair (Full Depth, Type I)	Sq. Yd.	5
Deck Slab Repair (Full Depth, Type II)	Sq. Yd.	5
Deck Slab Repair (Partial)	Sq. Yd.	38

MODEL: Default
 FILE NAME: Z:\15052.29_B&O_RR_Bridge\DCN\Bridges\final\Plotsheets\0820017-76K02-012-Deck_Slab_Repair (Span 9-10).dgn

WJE ENGINEERS ARCHITECTS MATERIAL SCIENTISTS
 Wss, Janney, Elstner Associates, Inc.
 330 Pfingsten Road
 Northbrook, Illinois 60062
 847.272.7400 tel | 847.291.9595 fax
 www.wje.com

USER NAME = khill	DESIGNED - SMG	REVISED -
	CHECKED - RAW	REVISED -
PLOT SCALE = 0.1667" / in.	DRAWN - SMG	REVISED -
PLOT DATE = 8/13/2024	CHECKED - RAW	REVISED -

**STATE OF ILLINOIS
 DEPARTMENT OF TRANSPORTATION**

**DECK SLAB REPAIR (SPANS 9-10)
 STRUCTURE NO. 082-0017**

SHEET 12 OF 114 SHEETS

F.A.I. RTE.	SECTION	COUNTY	TOTAL SHEETS	SHEET NO.
55/70	82-5VB-R-2	ST. CLAIR	254	150
CONTRACT NO. 76K02				
ILLINOIS		FED. AID PROJECT		

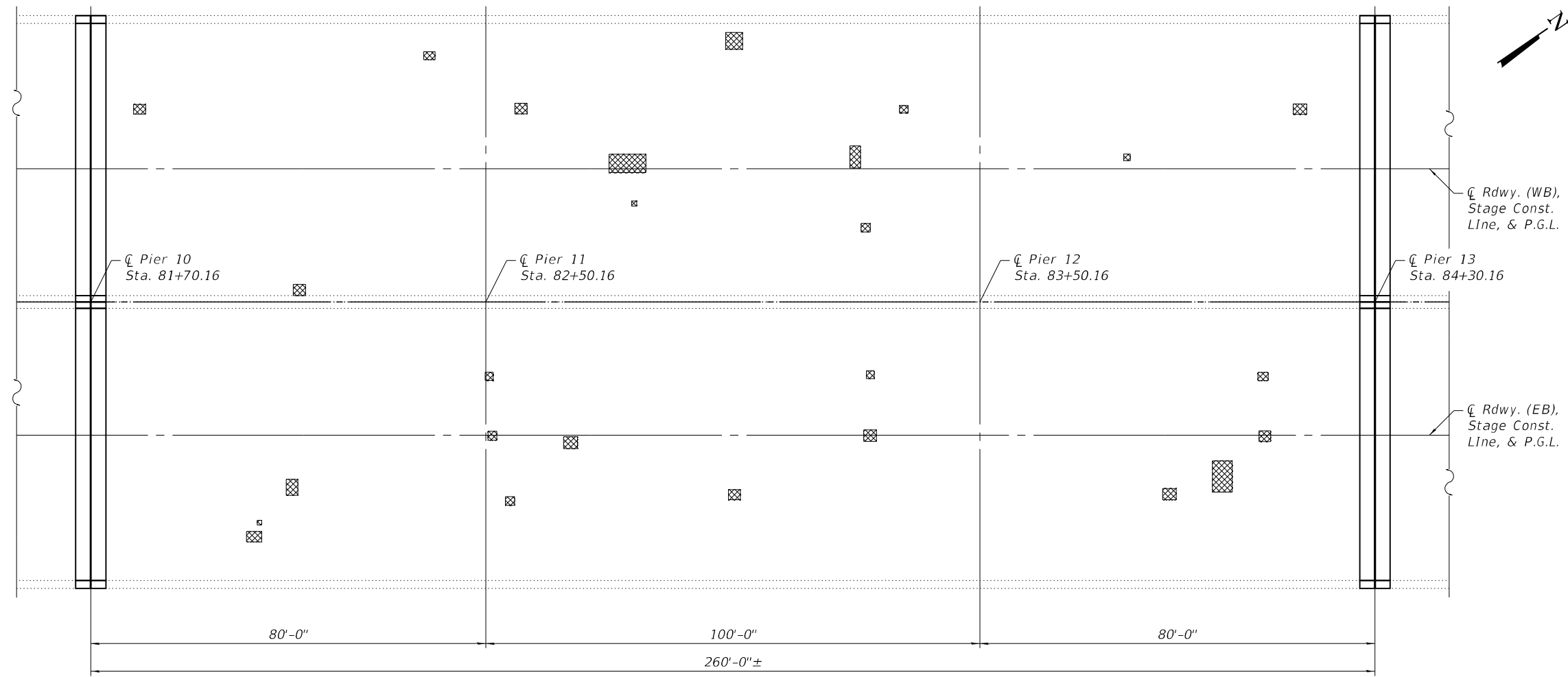

PLAN (SPANS 11 THRU 13)

Deck Slab Repair (Partial)

Notes:
 Deck sounding was performed in June 2020, with quantities increased to account for anticipated growth.
 The Resident Engineer will determine final patch locations and quantities in the field before bridge deck patching operations begin.
 See Sheet 17 of 114 for details of full depth or partial depth patching.
 See Sheet 19 of 114 for details and quantities of removal of existing concrete each side of joint.
 See Sheet 24 of 114 for details of replacement of concrete and new joints.

BRIDGE	PARTIAL DEPTH REPAIRS (Sq Yd)	FULL DEPTH REPAIRS (Sq Yd)	TOTAL (Sq Yd)
Westbound	11	6	17
Eastbound	11	6	17

BILL OF MATERIAL

Item	Unit	Total
Deck Slab Repair (Full Depth, Type I)	Sq. Yd.	6
Deck Slab Repair (Full Depth, Type II)	Sq. Yd.	6
Deck Slab Repair (Partial)	Sq. Yd.	22

MODEL: Default
 FILE NAME: Z:\15052.29_B&O_RR_Bridge\DCN\Bridges\final\Plotsheets\0820017-76K02-013-Deck_Slab_Repair (Span 11-13).dgn

WJE ENGINEERS ARCHITECTS MATERIAL SCIENTISTS
 Wss, Janney, Elstner Associates, Inc.
 330 Pfingsten Road
 Northbrook, Illinois 60062
 847.272.7400 tel | 847.291.9595 fax
 www.wje.com

USER NAME = khill	DESIGNED - SMG	REVISED -
PLOT SCALE = 0.1667" / in.	CHECKED - RAW	REVISED -
PLOT DATE = 8/13/2024	DRAWN - SMG	REVISED -
	CHECKED - RAW	REVISED -

**STATE OF ILLINOIS
 DEPARTMENT OF TRANSPORTATION**

**DECK SLAB REPAIR (SPANS 11-13)
 STRUCTURE NO. 082-0017**

SHEET 13 OF 114 SHEETS

F.A.I. RTE. 55/70	SECTION 82-5VB-R-2	COUNTY ST. CLAIR	TOTAL SHEETS 254	SHEET NO. 151
CONTRACT NO. 76K02				
ILLINOIS		FED. AID PROJECT		

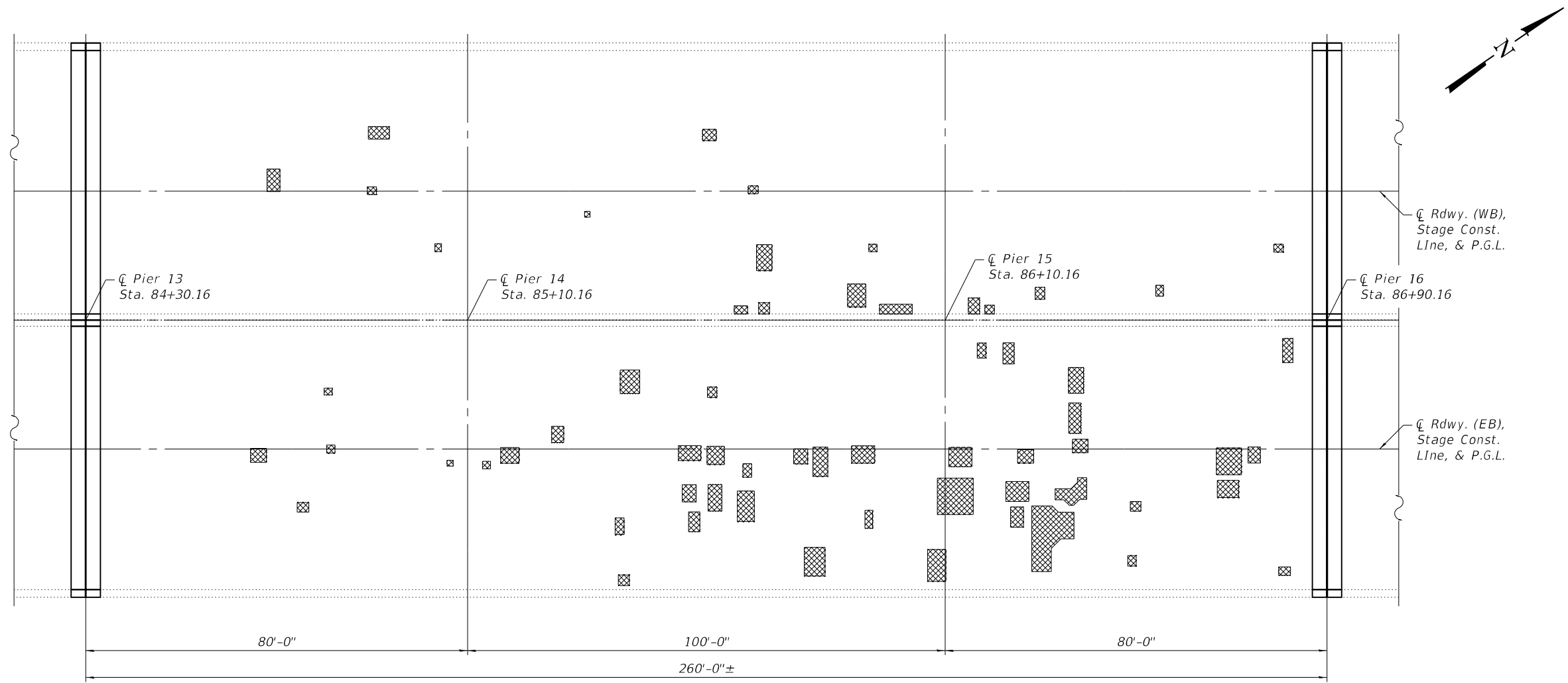

PLAN (SPANS 14 THRU 16)

Deck Slab Repair (Partial)

Notes:
 Deck sounding was performed in June 2020, with quantities increased to account for anticipated growth.
 The Resident Engineer will determine final patch locations and quantities in the field before bridge deck patching operations begin.
 See Sheet 17 of 114 for details of full depth or partial depth patching.
 See Sheet 19 of 114 for details and quantities of removal of existing concrete each side of joint.
 See Sheet 24 of 114 for details of replacement of concrete and new joints.

BRIDGE	PARTIAL DEPTH REPAIRS (Sq Yd)	FULL DEPTH REPAIRS (Sq Yd)	TOTAL (Sq Yd)
Westbound	16	6	22
Eastbound	79	12	91

BILL OF MATERIAL

Item	Unit	Total
Deck Slab Repair (Full Depth, Type I)	Sq. Yd.	9
Deck Slab Repair (Full Depth, Type II)	Sq. Yd.	9
Deck Slab Repair (Partial)	Sq. Yd.	95

MODEL: Default
 FILE NAME: Z:\15052.29_B&O_RR_Bridge\DCN\Bridges\final\Plotsheets\0820017-76K02-014-Deck_Slab_Repair (Span 14-16).dgn
 8/13/2024 9:41:31 AM

WJE ENGINEERS ARCHITECTS MATERIAL SCIENTISTS
 Wss, Janney, Elstner Associates, Inc.
 330 Pfingsten Road
 Northbrook, Illinois 60062
 847.272.7400 tel | 847.291.9595 fax
 www.wje.com

USER NAME = khill	DESIGNED - SMG	REVISED -
PLOT SCALE = 0.1667" / in.	CHECKED - RAW	REVISED -
PLOT DATE = 8/13/2024	DRAWN - SMG	REVISED -
	CHECKED - RAW	REVISED -

**STATE OF ILLINOIS
 DEPARTMENT OF TRANSPORTATION**

**DECK SLAB REPAIR (SPANS 14-16)
 STRUCTURE NO. 082-0017**

SHEET 14 OF 114 SHEETS

F.A.I. RTE.	SECTION	COUNTY	TOTAL SHEETS	SHEET NO.
55/70	82-5VB-R-2	ST. CLAIR	254	152
CONTRACT NO. 76K02				
		ILLINOIS	FED. AID PROJECT	

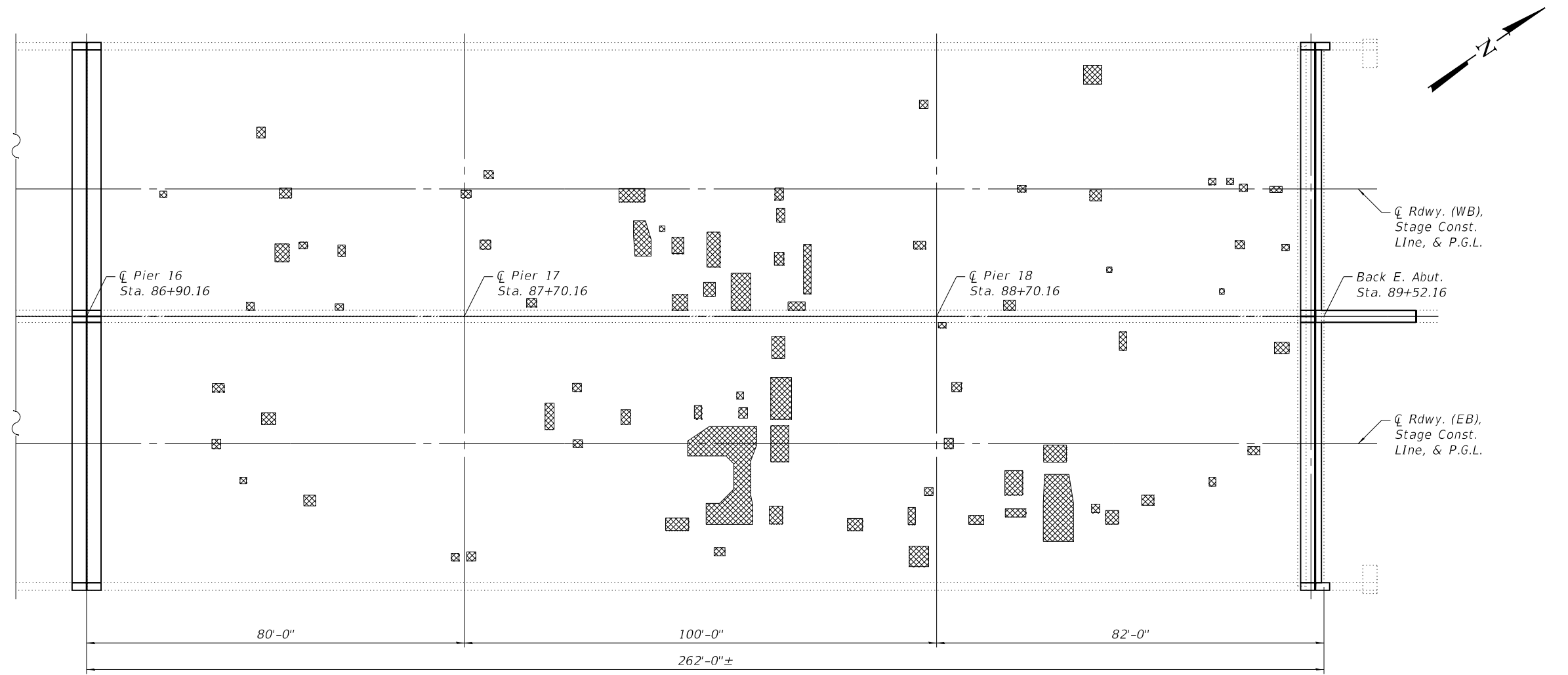

PLAN (SPANS 17 THRU 19)

Deck Slab Repair (Partial)

Notes:
 Deck sounding was performed in June 2020, with quantities increased to account for anticipated growth.
 The Resident Engineer will determine final patch locations and quantities in the field before bridge deck patching operations begin.
 See Sheet 17 of 114 for details of full depth or partial depth patching.
 See Sheets 18 & 19 of 114 for details and quantities of removal of existing concrete each side of joint.
 See Sheets 24 thru 26 of 114 for details of replacement of concrete and new joints.

BRIDGE	PARTIAL DEPTH REPAIRS (Sq Yd)	FULL DEPTH REPAIRS (Sq Yd)	TOTAL (Sq Yd)
Westbound	32	8	40
Eastbound	70	12	82

BILL OF MATERIAL

Item	Unit	Total
Deck Slab Repair (Full Depth, Type I)	Sq. Yd.	10
Deck Slab Repair (Full Depth, Type II)	Sq. Yd.	10
Deck Slab Repair (Partial)	Sq. Yd.	102

MODEL: Default
 FILE NAME: Z:\15052.29_B&O_RR_Bridge\DCN\Bridges\0820017-76K02-015-Deck_Slab_Repair (Span 17-19).dgn

WJE ENGINEERS ARCHITECTS MATERIAL SCIENTISTS
 Wss, Janney, Elstner Associates, Inc.
 330 Pfingsten Road
 Northbrook, Illinois 60062
 847.272.7400 tel | 847.291.9595 fax
 www.wje.com

USER NAME = khill	DESIGNED - SMG	REVISED -
PLOT SCALE = 0.1667" / in.	CHECKED - RAW	REVISED -
PLOT DATE = 8/13/2024	DRAWN - SMG	REVISED -
	CHECKED - RAW	REVISED -

STATE OF ILLINOIS
DEPARTMENT OF TRANSPORTATION

DECK SLAB REPAIR (SPANS 17-19)
STRUCTURE NO. 082-0017

SHEET 15 OF 114 SHEETS

F.A.I. RTE.	SECTION	COUNTY	TOTAL SHEETS	SHEET NO.
55-70	82-5VB-R-2	ST. CLAIR	254	153
CONTRACT NO. 76K02				
		ILLINOIS	FED. AID PROJECT	

57'-11½" out to out

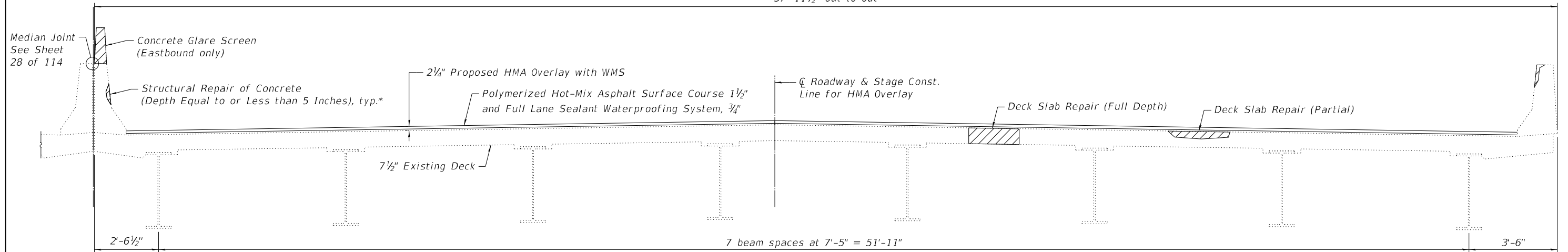

CROSS SECTION

(Looking East)

(Eastbound Structure shown, Westbound Structure similar)

* A nominal quantity greater than 5 inches has been assumed.

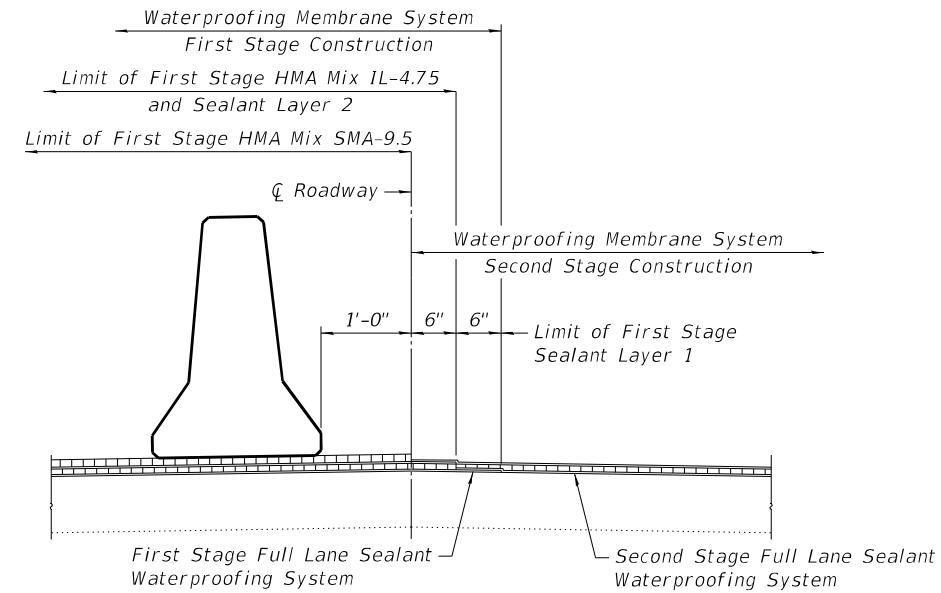

WATERPROOFING TREATMENT AT STAGE CONSTRUCTION LINE

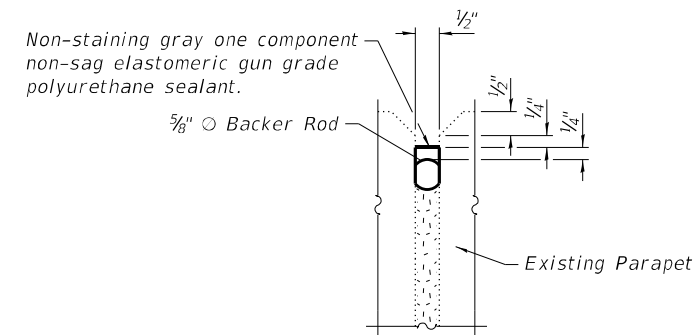

PARAPET JOINT DETAILS

Notes:

The Resident Engineer will determine final concrete repair locations and quantities in the field before repair operations begin. For details of Structural Repair of Concrete, see Sheet 17 of 114. For locations and quantities of Deck Slab Repairs see Sheets 9 thru 15 of 114. Existing cover to transverse reinforcement (top mat) is approximately 2.5" and can vary from 1.4" to 3.9" (findings based on 2020 nondestructive testing). Partial depth repairs per the details shown on Sheet 17 of 114 are expected at nearly all locations. Adjust depth of removal to accommodate reinforcement. For details of Median Joint Repair, see Sheet 28 of 114. For additional staging information see Sheet 7 and 8 of 114. For Drainage Scupper Adjustment Details, see Sheet 29 of 114. Refer to Special Provisions for "Cleaning Drainage System". Coordinate cleaning operations with other work to ensure that cleaning method does not damage the existing drainage system.

BILL OF MATERIAL

Item	Unit	Total
Structural Repair of Concrete (Depth Equal to or Less than 5 Inches)	Sq. Ft.	977
Structural Repair of Concrete (Depth Greater than 5 Inches)	Sq. Ft.	109
Polymerized Hot-Mix Asphalt Surface Course, Stone Matrix Asphalt, 9.5, Mix "E", N80	Ton	1,661
Full Lane Sealant Waterproofing System	Sq. Yd.	19,777
Polyurethane Sealant	Foot	1,347
Concrete Glare Screen	Foot	356
Cleaning Drainage System	L. Sum	1

MODEL: Default
FILE NAME: Z:\1505229_B&O_RR_Bridge\DCN\Bridg\final\Plotsheets\0820017-76K02-016-Cross_Section.dgn

WJE ENGINEERS ARCHITECTS MATERIAL SCIENTISTS
Wiss, Janney, Elstner Associates, Inc.
330 Pfingsten Road
Northbrook, Illinois 60062
847.272.7400 tel | 847.291.9595 fax
www.wje.com

USER NAME = khill	DESIGNED - SMG	REVISED -
PLOT SCALE = 0.1667"/in.	CHECKED - RAW	REVISED -
PLOT DATE = 8/13/2024	DRAWN - SMG	REVISED -
	CHECKED - RAW	REVISED -

**STATE OF ILLINOIS
DEPARTMENT OF TRANSPORTATION**

**DECK CROSS SECTION
STRUCTURE NO. 082-0017**

SHEET 16 OF 114 SHEETS

F.A.I. RTE.	SECTION	COUNTY	TOTAL SHEETS	SHEET NO.
55/70	82-5VB-R-2	ST. CLAIR	254	154
CONTRACT NO. 76K02				
		ILLINOIS	FED. AID PROJECT	

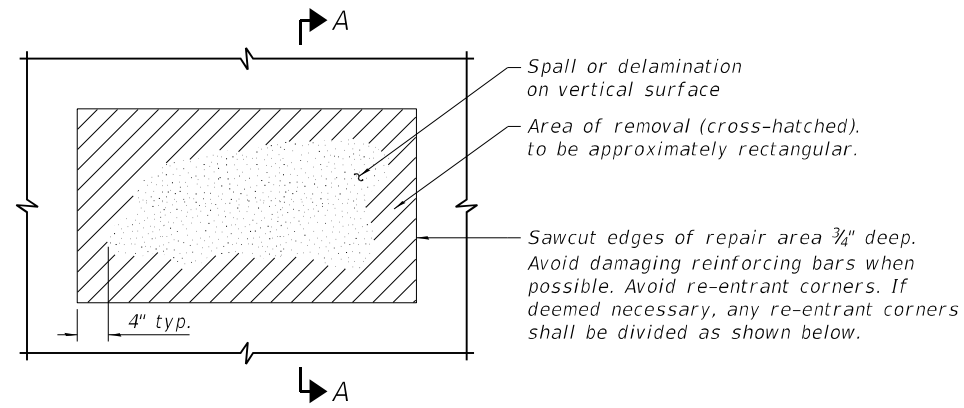

VERTICAL SURFACE REPAIR DETAIL

At Substructure and Parapet

Note:
See special provisions for additional requirements when reinforcing bars are encountered.

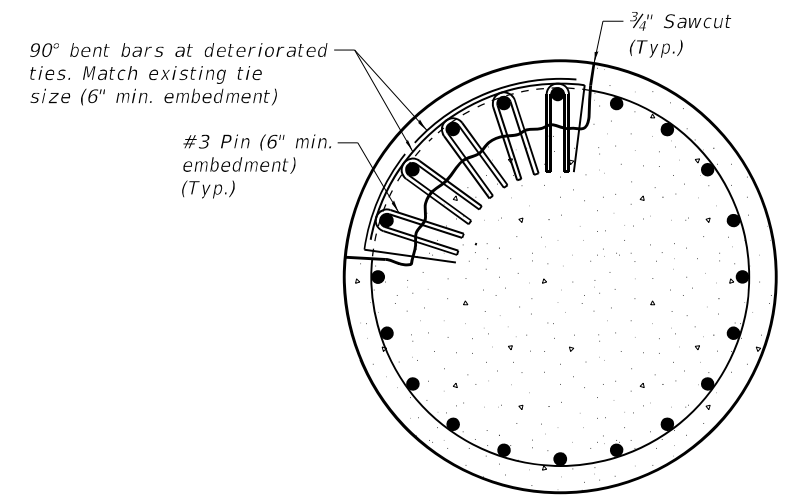
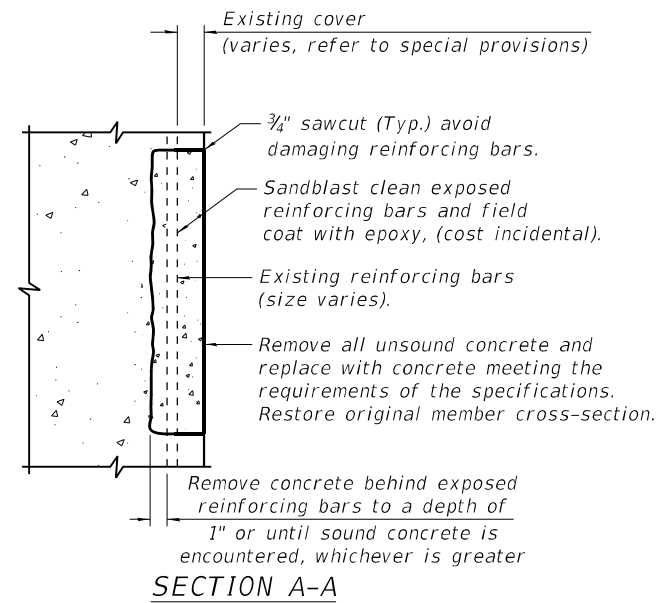

COLUMN REPAIR AT DETERIORATED TIE

Notes:
Circle column shown. Square column similar.
Patch shall extend 4\"/>

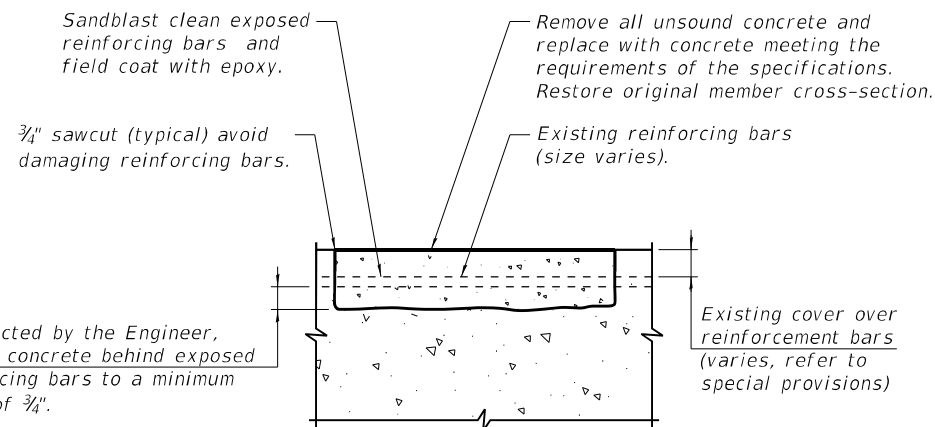

HORIZONTAL SURFACE REPAIR (PARTIAL DEPTH)

At Bridge Deck, Parapet, and Substructure

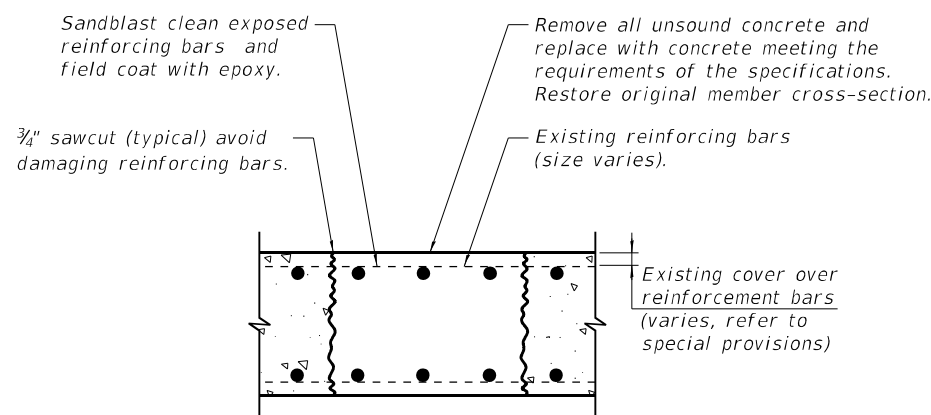

HORIZONTAL SURFACE REPAIR (FULL DEPTH)

At Bridge Deck

Notes:
Where construction joints occur within patches due to staging requirements, concrete removal shall extend 1 inch into previously repaired regions such that all existing steel is cleaned and coated. See Roadway Plans for traffic control staging requirements.
See special provisions for additional requirements when reinforcing bars are encountered and when removal extends below half of deck thickness.

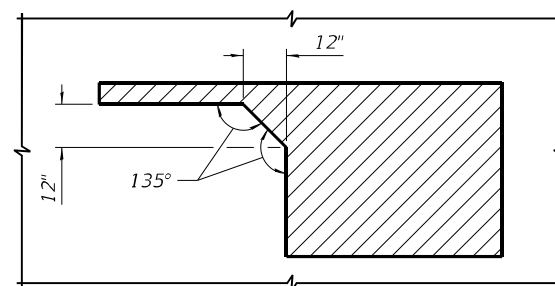

RE-ENTRANT CORNER MODIFICATIONS

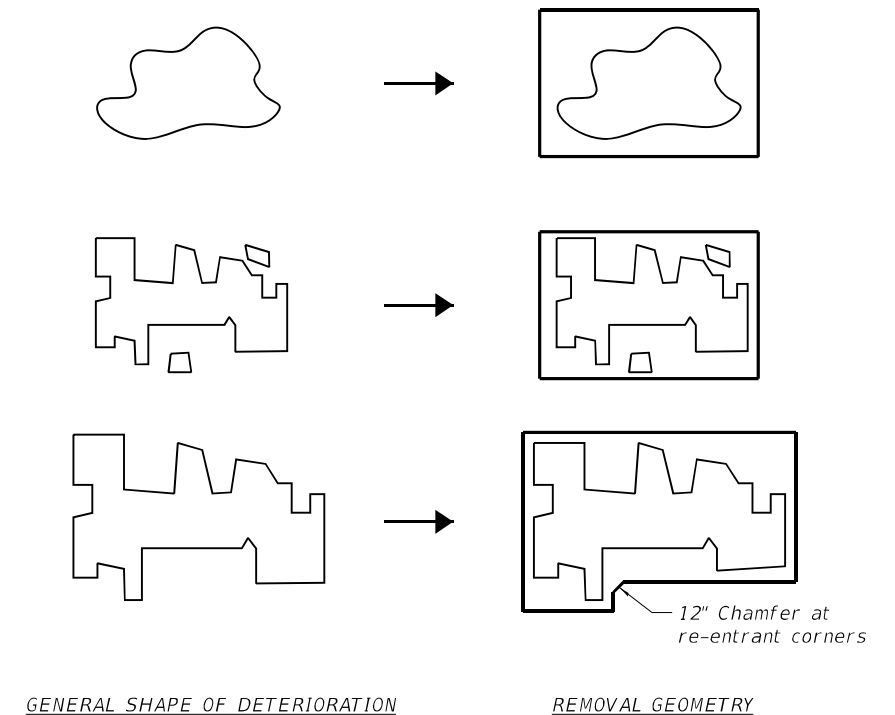

TYPICAL CONCRETE REPAIR GEOMETRY

MODEL: Default
FILE NAME: Z:\15052229 B&O RR Bridge\DNV\Bridg\final\Plotsheets\0820017-76K02-017-Concrete_Repair_Details.dgn

WJE ENGINEERS ARCHITECTS MATERIAL SCIENTISTS
Wiss, Janney, Elstner Associates, Inc.
330 Pfingsten Road
Northbrook, Illinois 60062
847.272.7400 tel | 847.291.9595 fax

USER NAME = khill	DESIGNED - SMG	REVISED -
PLOT SCALE = 0.1667"/in.	CHECKED - RAW	REVISED -
PLOT DATE = 8/13/2024	DRAWN - SMG	REVISED -
	CHECKED - RAW	REVISED -

**STATE OF ILLINOIS
DEPARTMENT OF TRANSPORTATION**

**CONCRETE REPAIR DETAILS
STRUCTURE NO. 082-0017**

SHEET 17 OF 114 SHEETS

F.A.I. RTE.	SECTION	COUNTY	TOTAL SHEETS	SHEET NO.
55/70	82-5VB-R-2	ST. CLAIR	254	155
CONTRACT NO. 76K02				
		ILLINOIS	FED. AID PROJECT	

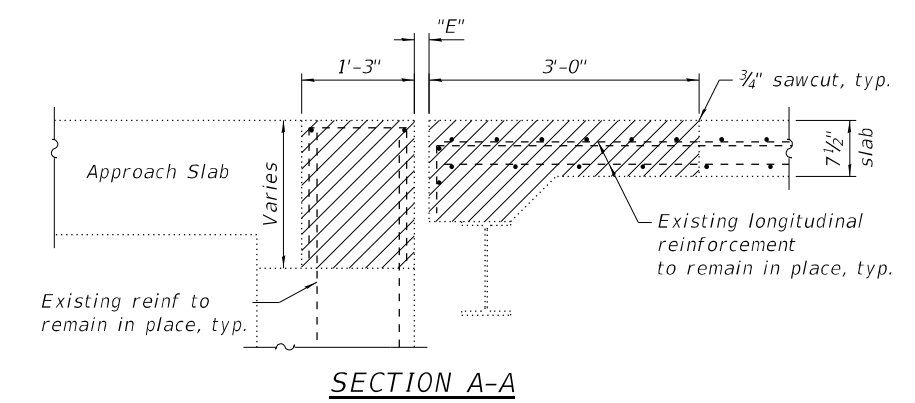
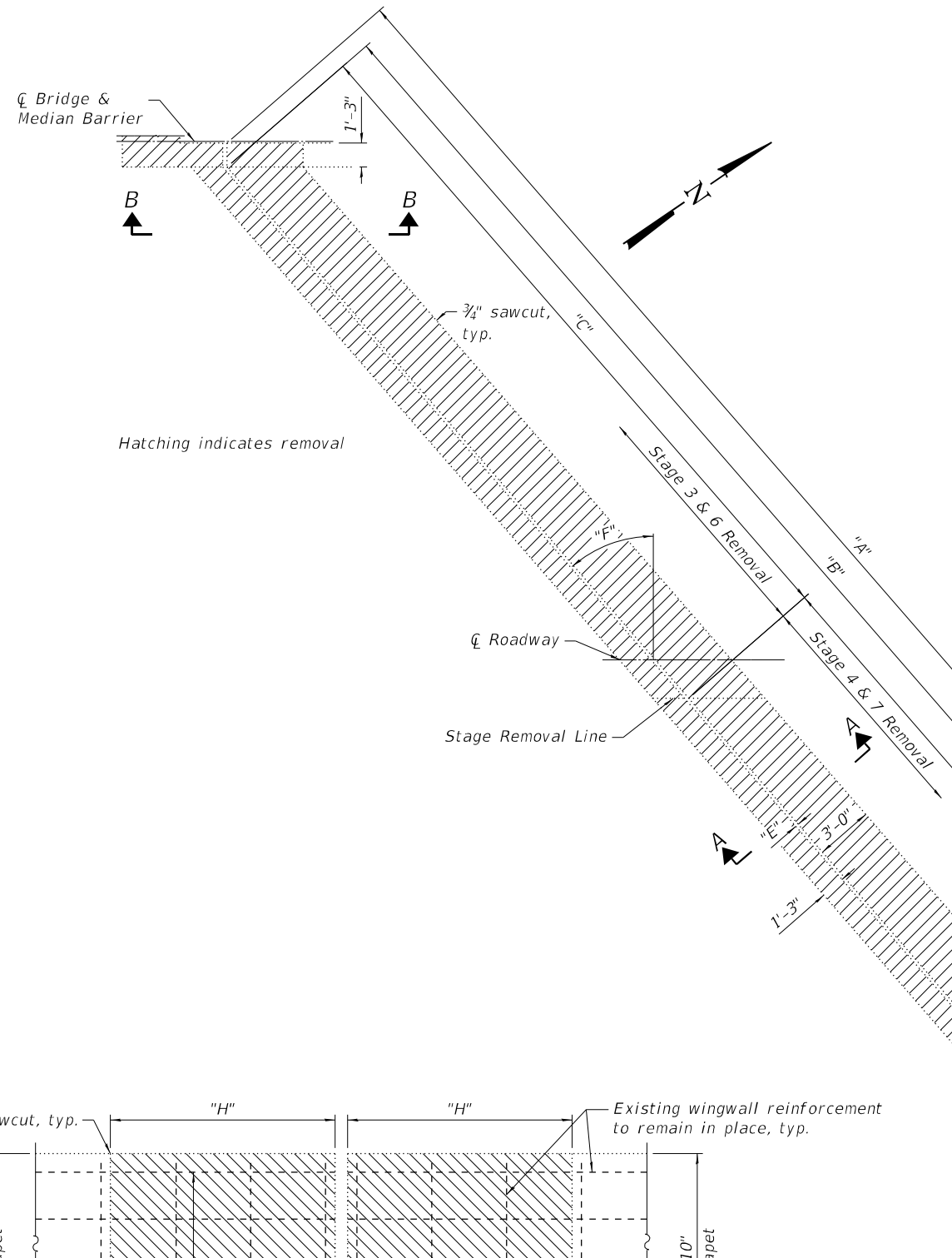

SECTION A-A

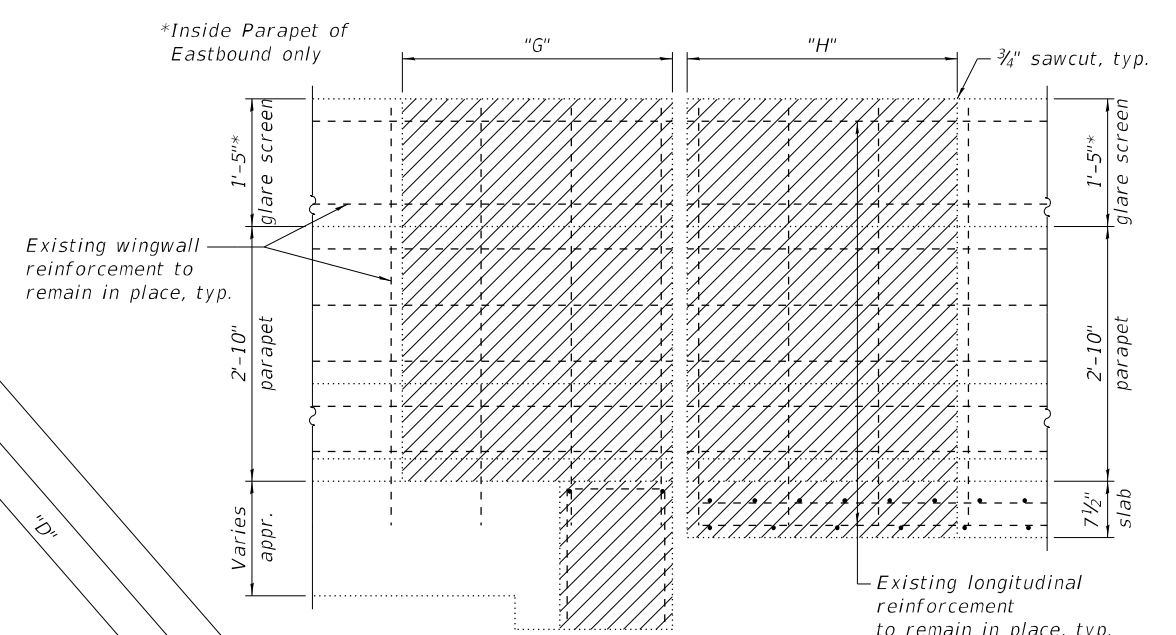

SECTION B-B

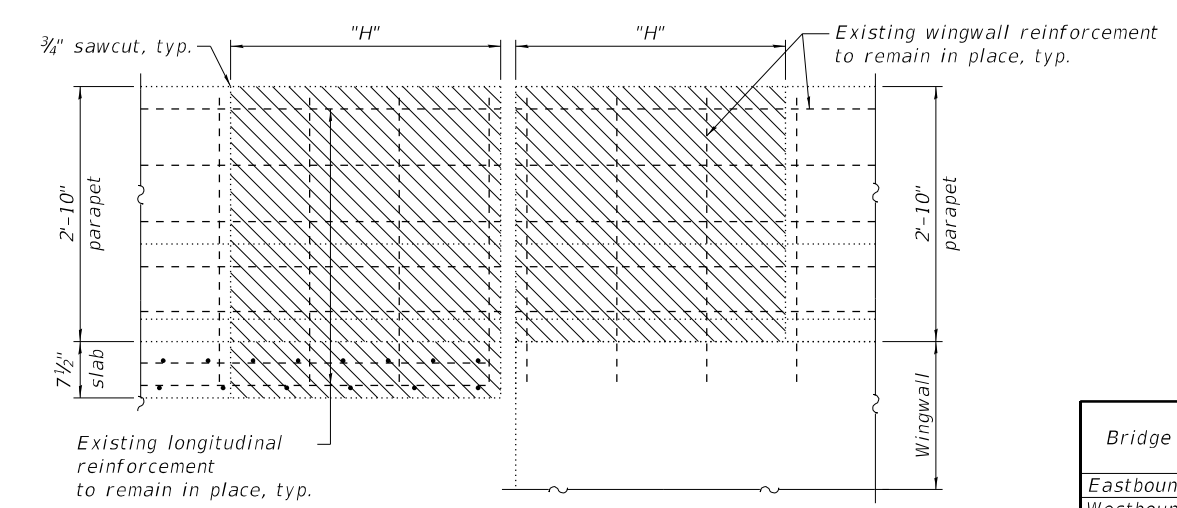

SECTION C-C

PLAN
West abutment joint shown. East abutment similar.
Eastbound joint shown. Westbound joint similar.

CONCRETE REMOVAL

Bridge	Location	Dimension "A"	Dimension "B"	Dimension "C"	Dimension "D"	Dimension "E"	Angle "F"	Dimension "G"	Dimension "H"	Concrete Removal (Cu Yd)
Eastbound	W Abut	76'-9 1/2"	73'-0 1/2"	36'-8 3/8"	36'-3 7/8"	2"	41°	5'-3"	3'-11 3/4"	13.5
Westbound	W Abut	76'-9 1/2"	73'-0 1/2"	36'-8 3/8"	36'-3 7/8"	2"	41°	3'-0"	3'-11 3/4"	13.1
Eastbound	E Abut	57'-11 1/2"	55'-1 1/2"	27'-8 1/2"	27'-5"	2"	0°	21'-3"	3'-0"	12.3
Westbound	E Abut	57'-11 1/2"	55'-1 1/2"	27'-8 1/2"	27'-5"	2"	0°	21'-3"	3'-0"	11.8

Note:
Existing reinforcement shall be cleaned and incorporated into the new construction. Cost included with Concrete Removal.

BILL OF MATERIAL

Item	Unit	Total
Concrete Removal	Cu. Yd.	50.7

MODEL: Default
FILE NAME: Z:\15052229 B&O RR Bridge\DN\Bridge\final\Plotsheets\0820017-76K02-018-joinL_Demo (Abutments).dgn
8/13/2024 9:41:33 AM

WJE ENGINEERS ARCHITECTS MATERIAL SCIENTISTS
Wiss, Janney, Elstner Associates, Inc.
330 Pfingsten Road
Northbrook, Illinois 60062
847.272.7400 tel | 847.291.9595 fax

USER NAME = khill	DESIGNED - SMG	REVISED -
PLOT SCALE = 0.1667"/in.	CHECKED - RAW	REVISED -
PLOT DATE = 8/13/2024	DRAWN - SMG	REVISED -
	CHECKED - RAW	REVISED -

STATE OF ILLINOIS
DEPARTMENT OF TRANSPORTATION

EXPANSION JOINT REMOVAL DETAILS (ABUTMENTS)
STRUCTURE NO. 082-0017

SHEET 18 OF 114 SHEETS

F.A.I. RTE.	SECTION	COUNTY	TOTAL SHEETS	SHEET NO.
55/70	82-5VB-R-2	ST. CLAIR	254	156
CONTRACT NO. 76K02				
ILLINOIS		FED. AID PROJECT		

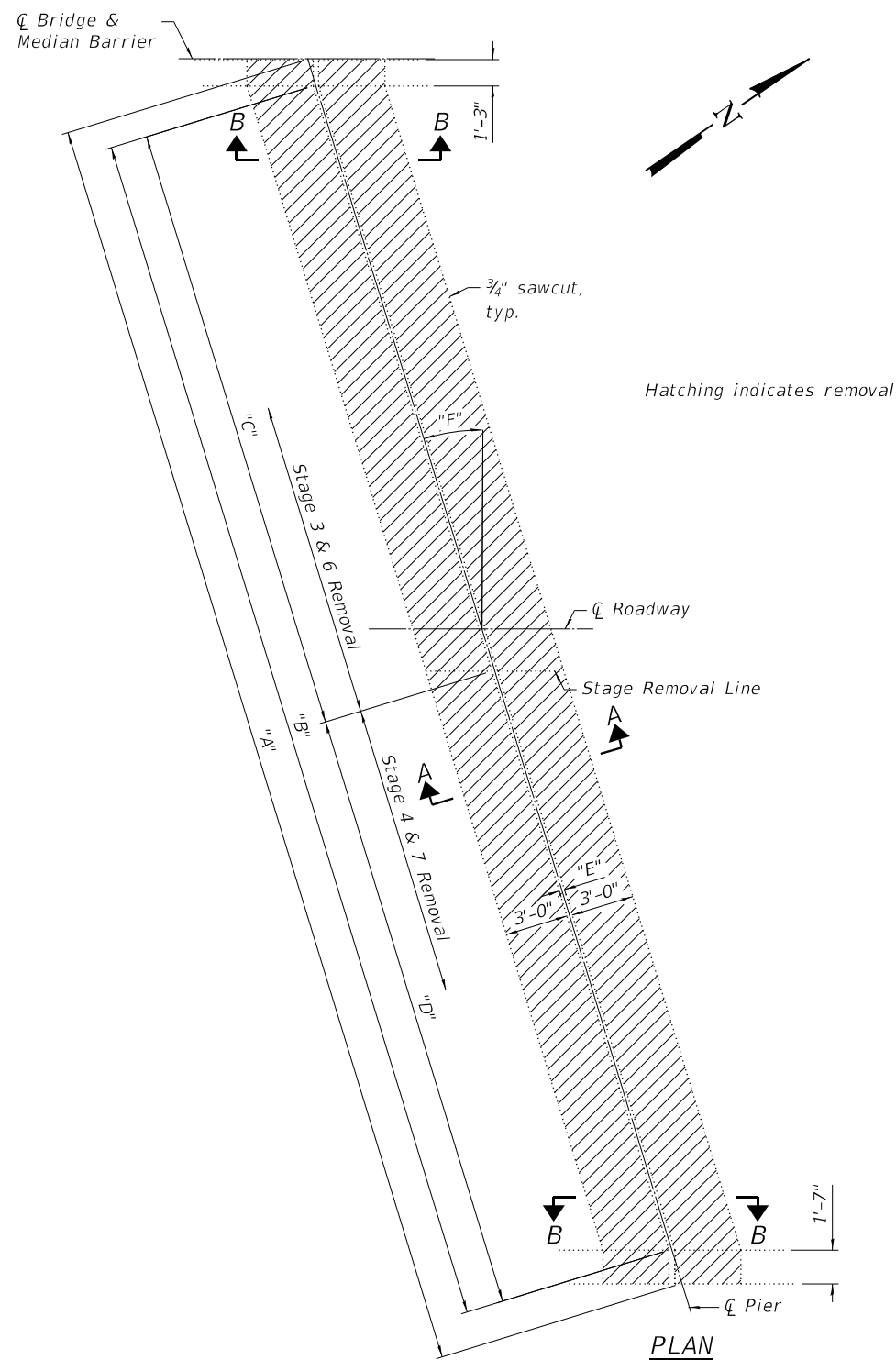

Pier 8 joint shown. Other piers similar.
Eastbound joint shown. Westbound similar.

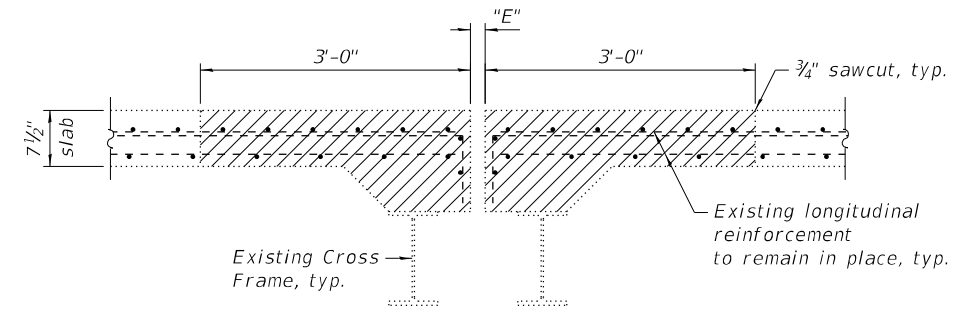

SECTION A-A

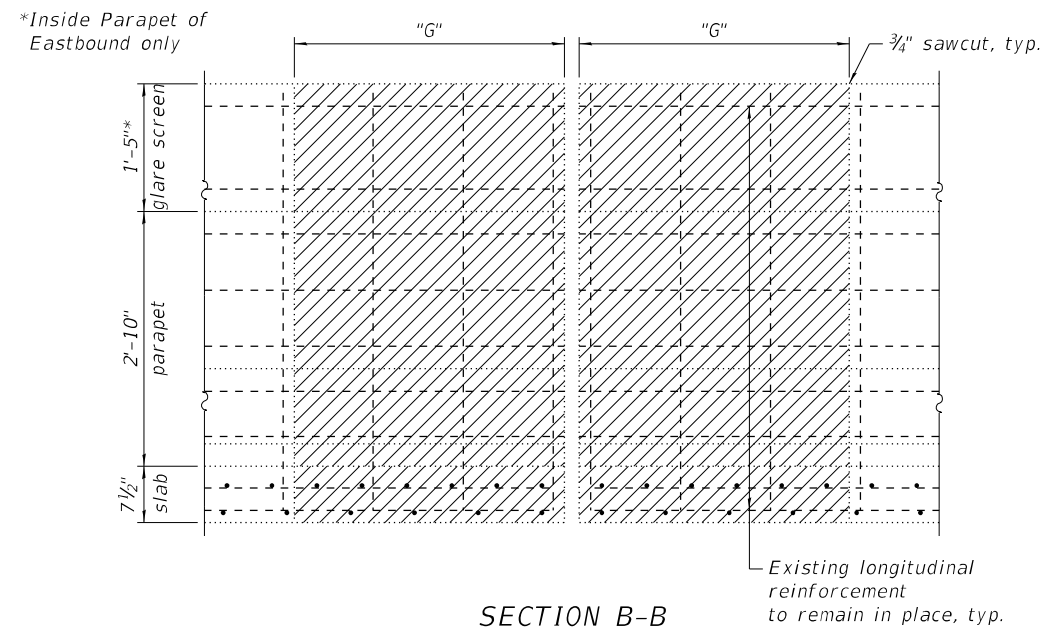

SECTION B-B

CONCRETE REMOVAL

Location	Dimension "A"	Dimension "B"	Dimension "C"	Dimension "D"	Dimension "E"	Angle "F"	Dimension "G"	**Concrete Removal (Cu Yd)
Pier 3	76'-9 1/2"	73'-0 1/2"	36'-8 5/8"	36'-3 7/8"	3"	41°	3'-11 3/4"	31.6
Pier 6	76'-9 1/2"	73'-0 1/2"	36'-8 5/8"	36'-3 7/8"	2 1/2"	41°	3'-11 3/4"	31.6
Pier 7	76'-9 1/2"	73'-0 1/2"	36'-8 5/8"	36'-3 7/8"	2 1/2"	41°	3'-11 3/4"	31.6
Pier 8	60'-7 1/4"	57'-7 3/4"	28'-11 3/4"	28'-8"	3"	17°	3'-1 5/8"	25.0
Pier 9	60'-7 1/4"	57'-7 3/4"	28'-11 3/4"	28'-8"	2 1/2"	17°	3'-1 5/8"	25.0
Pier 10	57'-11 1/2"	55'-1 1/2"	27'-8 1/2"	27'-5"	2"	0°	3'-0"	23.9
Pier 13	57'-11 1/2"	55'-1 1/2"	27'-8 1/2"	27'-5"	1 1/2"	0°	3'-0"	23.9
Pier 16	57'-11 1/2"	55'-1 1/2"	27'-8 1/2"	27'-5"	2"	0°	3'-0"	23.9

**Concrete Removal quantities provided include both Eastbound and Westbound decks.

Notes:
Prior to concrete removal, provide protective shielding extending 10 feet on either side of pier if adjacent to roadway or track. See Sheet 4 and 5 of 114 for work adjacent to railroads. Refer to special provisions for additional requirements.
Existing reinforcement shall be cleaned and incorporated into the new construction. Cost included with Concrete Removal.

BILL OF MATERIAL

Item	Unit	Total
Concrete Removal	Cu. Yd.	216.5

MODEL: Default
FILE NAME: Z:\1505229_B&O RR Bridge\DN\Bridge\final\Plotsheets\0820017-76K02-019-01\Int_Demo (Piers).dgn

WJE ENGINEERS ARCHITECTS MATERIAL SCIENTISTS
Wiss, Janney, Elstner Associates, Inc.
330 Pfingsten Road
Northbrook, Illinois 60062
847.272.7400 tel | 847.291.9595 fax
www.wje.com

USER NAME = khill	DESIGNED - SMG	REVISED -
PLOT SCALE = 0.1667"/in.	CHECKED - RAW	REVISED -
PLOT DATE = 8/13/2024	DRAWN - SMG	REVISED -
	CHECKED - RAW	REVISED -

STATE OF ILLINOIS
DEPARTMENT OF TRANSPORTATION

EXPANSION JOINT REMOVAL DETAILS (PIERS)
STRUCTURE NO. 082-0017

SHEET 19 OF 114 SHEETS

F.A.I. RTE.	SECTION	COUNTY	TOTAL SHEETS	SHEET NO.
55/70	82-5VB-R-2	ST. CLAIR	254	157
CONTRACT NO. 76K02				
ILLINOIS		FED. AID PROJECT		

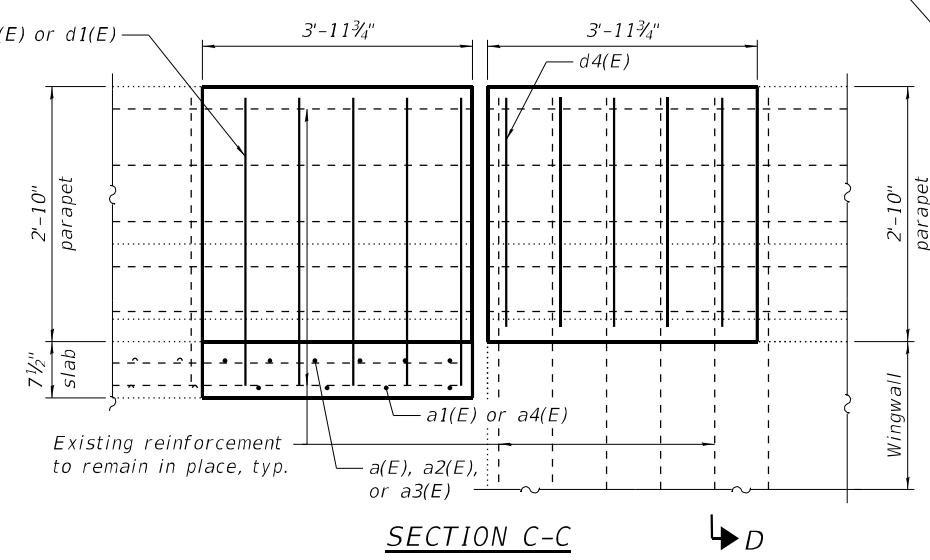
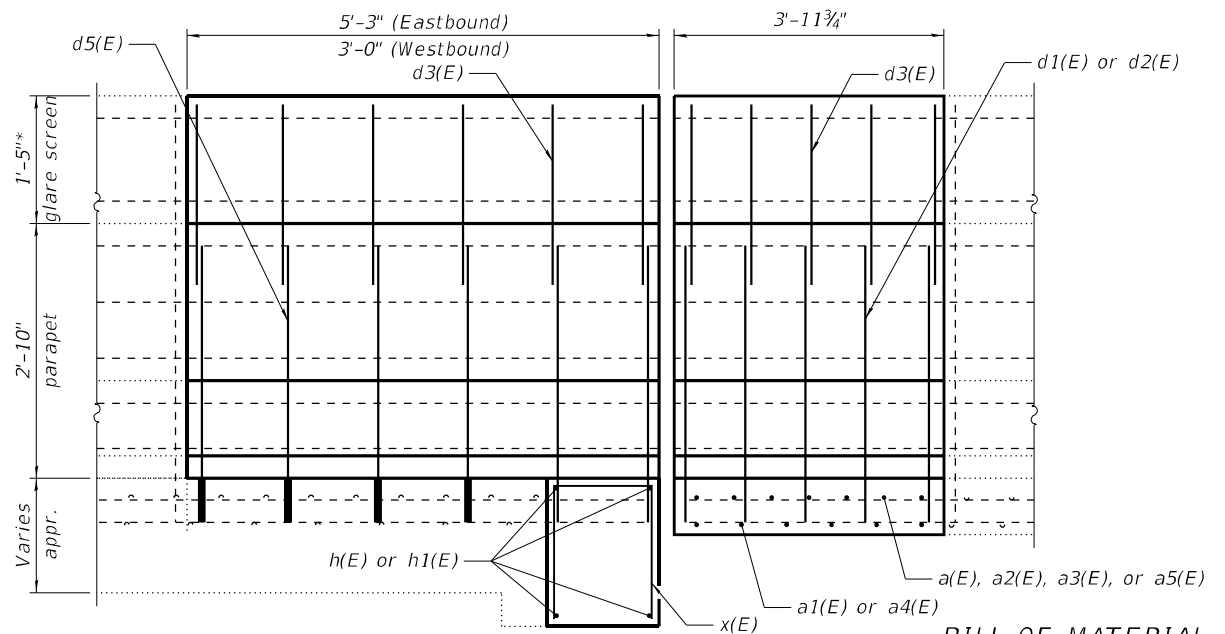
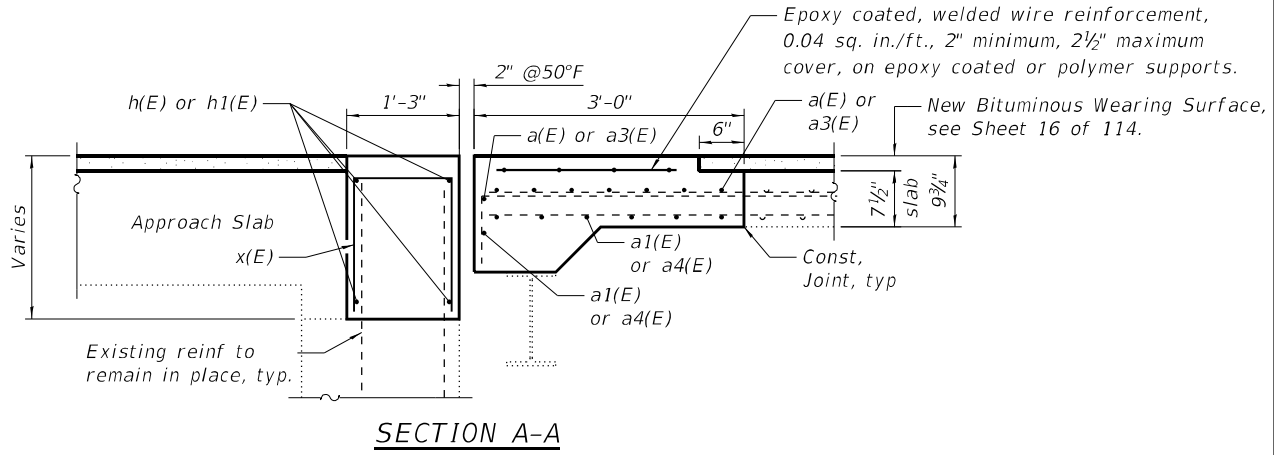
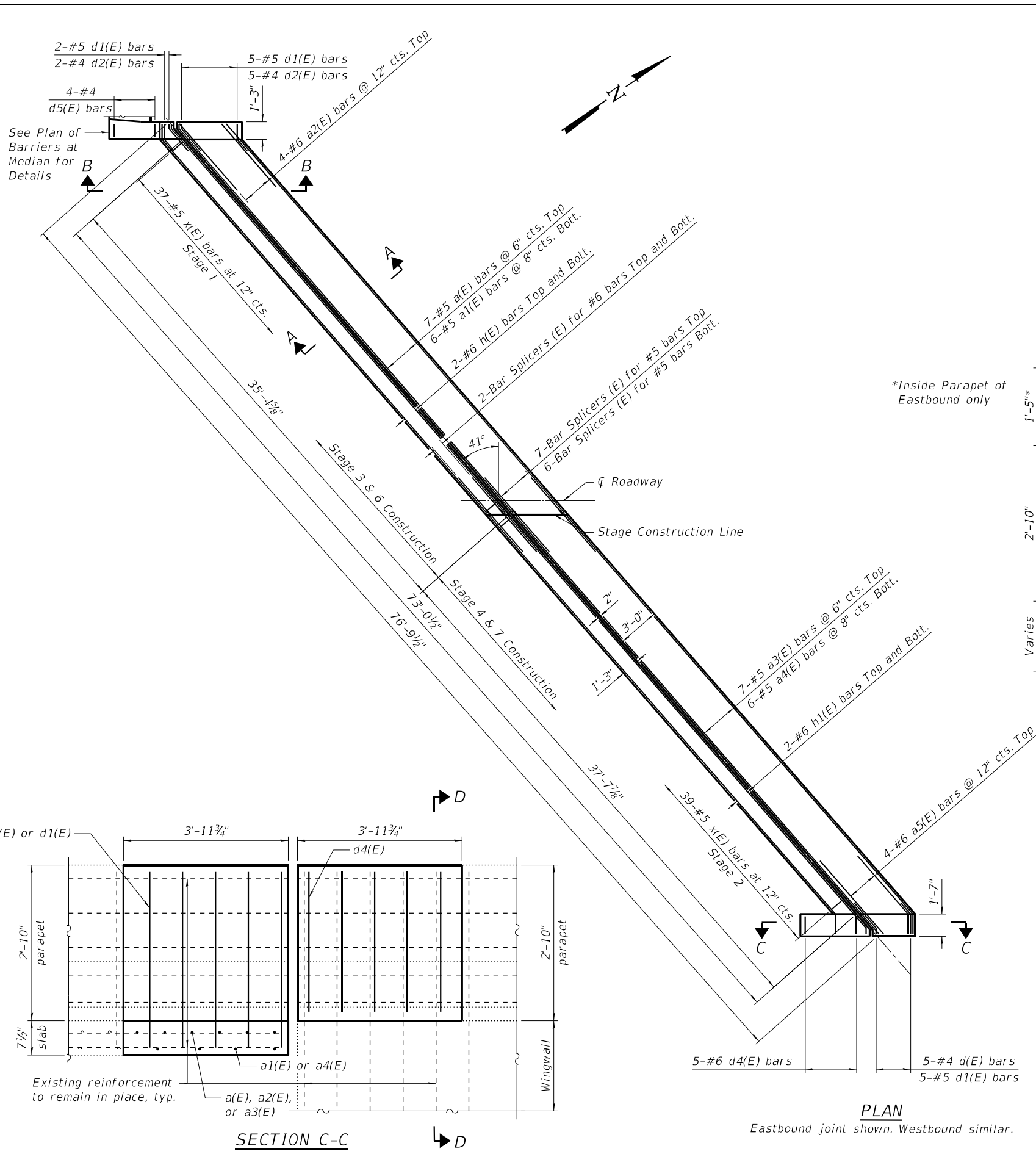

SECTION B-B

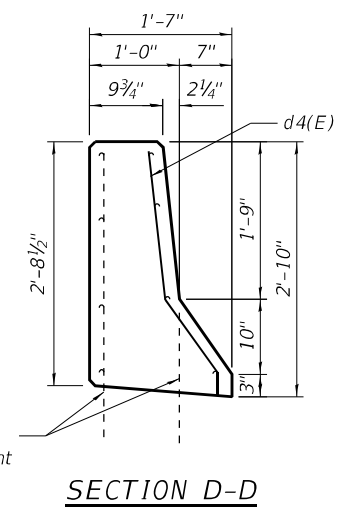

SECTION D-D

BILL OF MATERIAL

Bar	No.	Size	Length	Shape
a(E)	14	#5	36'-8"	—
a1(E)	12	#5	36'-8"	—
a2(E)	8	#6	5'-11"	—
a3(E)	14	#5	39'-2"	—
a4(E)	12	#5	39'-2"	—
a5(E)	8	#6	6'-11"	—
h(E)	8	#6	36'-8"	—
h1(E)	8	#6	39'-2"	—
d(E)	10	#4	5'-7"	┘
d1(E)	24	#5	3'-11"	┘
d2(E)	14	#4	4'-9"	┘
d3(E)	11	#5	2'-0"	—
d4(E)	10	#6	2'-11"	┘
d5(E)	8	#4	3'-5"	┘
e(E)	8	#5	4'-11"	—
e1(E)	5	#5	2'-8"	—
x(E)	152	#5	3'-6"	┘
Reinforcement Bars, Epoxy Coated		Pound	4,000	
Concrete Superstructure		Cu. Yd.	30.5	
Welded Wire Reinforcement		Sq. Yd.	50	
Bar Splicers		Each	34	

Notes:
 For details of expansion joint, see Sheet 27 of 114.
 Bend deck reinforcement in field to fit skewed deck.
 Bill of Material includes Eastbound and Westbound decks.
 Incorporate existing wingwall reinforcement into new construction.

PLAN
 Eastbound joint shown. Westbound similar.

MODEL: Default
 FILE NAME: Z:\1505229_B&O RR Bridge\DN\Bridg\final\Plotsheets\0820017-76K02-020-Joint Replacement West Abutment.dgn
 8/13/2024 9:41:34 AM

WJE ENGINEERS ARCHITECTS MATERIAL SCIENTISTS
 Wss, Janney, Elstner Associates, Inc.
 330 Pfingsten Road
 Northbrook, Illinois 60062
 847.272.7400 tel | 847.291.9595 fax

USER NAME = khill	DESIGNED - SMG	REVISED -
PLOT SCALE = 0.1667"/in.	CHECKED - RAW	REVISED -
PLOT DATE = 8/13/2024	DRAWN - SMG	REVISED -
	CHECKED - RAW	REVISED -

**STATE OF ILLINOIS
 DEPARTMENT OF TRANSPORTATION**

**EXPANSION JOINT REPLACEMENT DETAILS (WEST ABUTMENT)
 STRUCTURE NO. 082-0017**

SHEET 20 OF 114 SHEETS

F.A.I. RTE.	SECTION	COUNTY	TOTAL SHEETS	SHEET NO.
55/70	82-5VB-R-2	ST. CLAIR	254	158
CONTRACT NO. 76K02				
ILLINOIS FED. AID PROJECT				

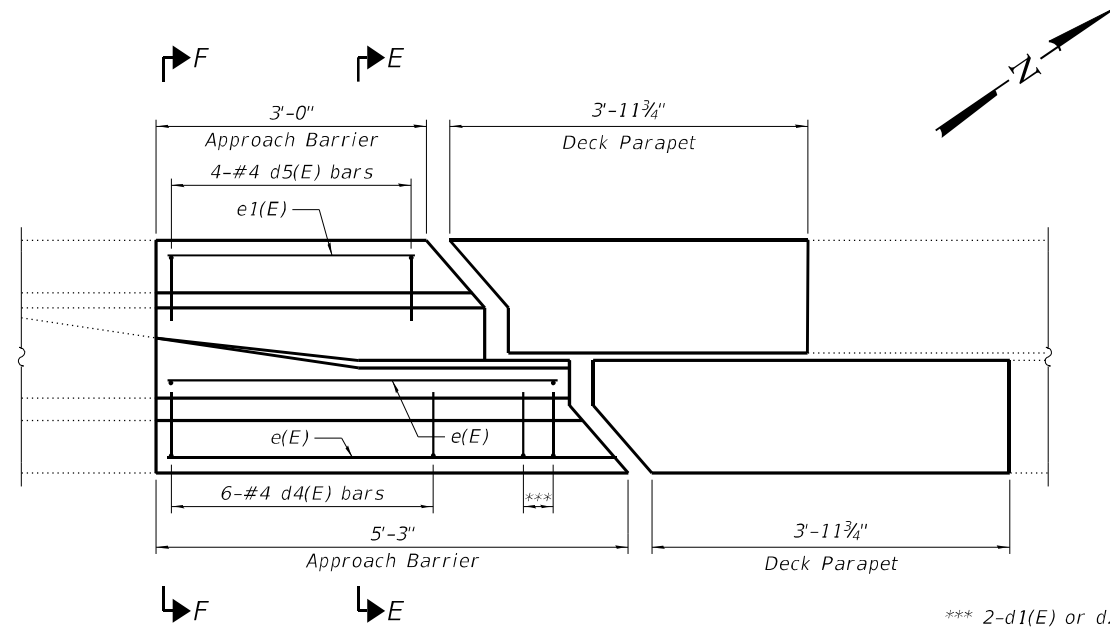

PLAN OF BARRIERS AT MEDIAN
(Deck parapet reinforcement not shown)

*** 2-d1(E) or d2(E) bars

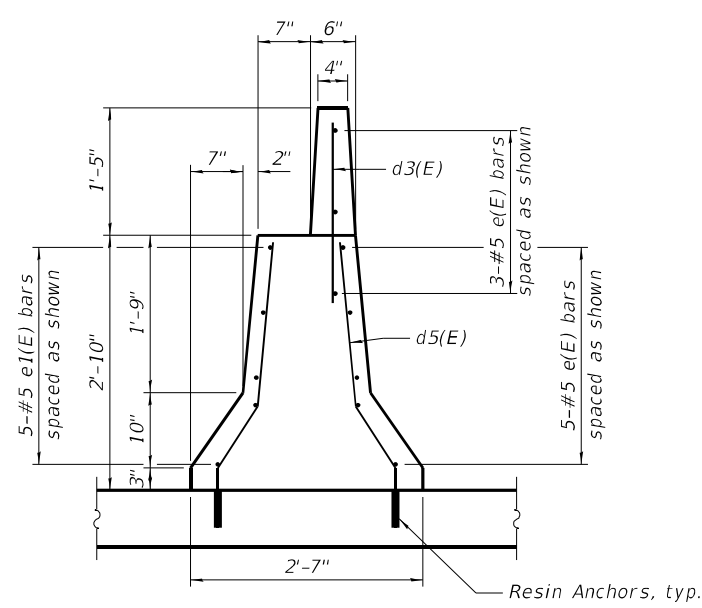

SECTION E-E

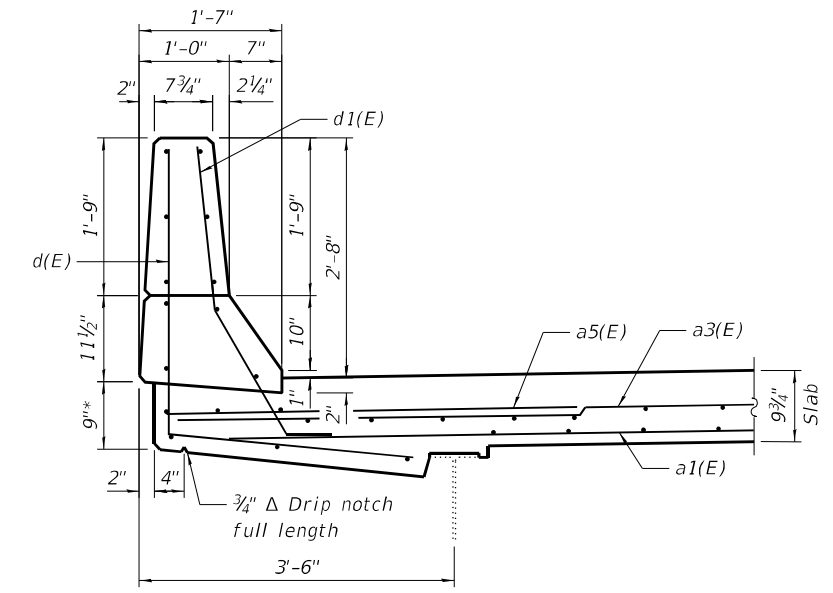

SECTION THRU OUTSIDE DECK PARAPET
*Adjust to match existing dimensions

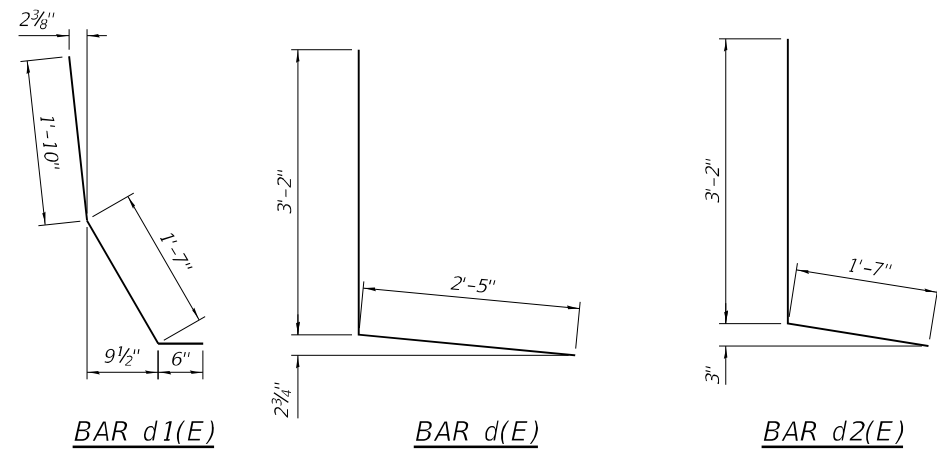

BAR d1(E)

BAR d(E)

BAR d2(E)

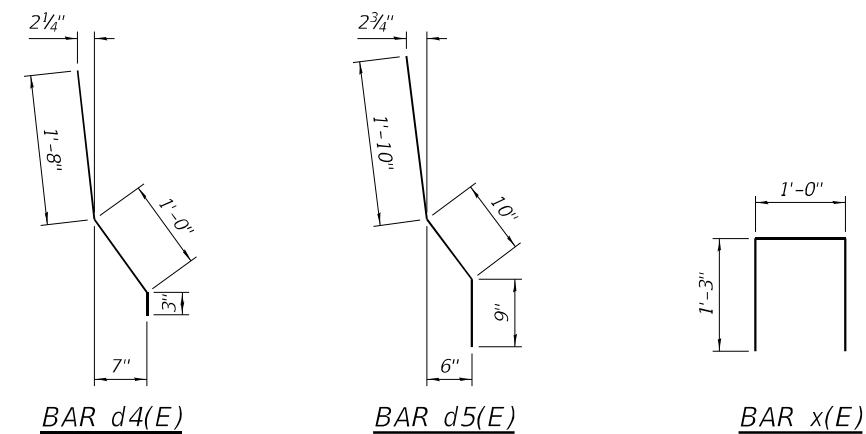

BAR d4(E)

BAR d5(E)

BAR x(E)

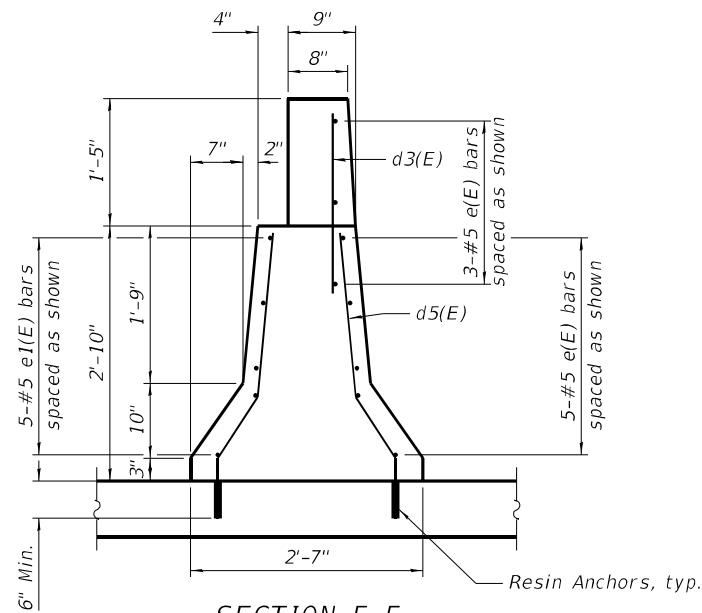

SECTION F-F

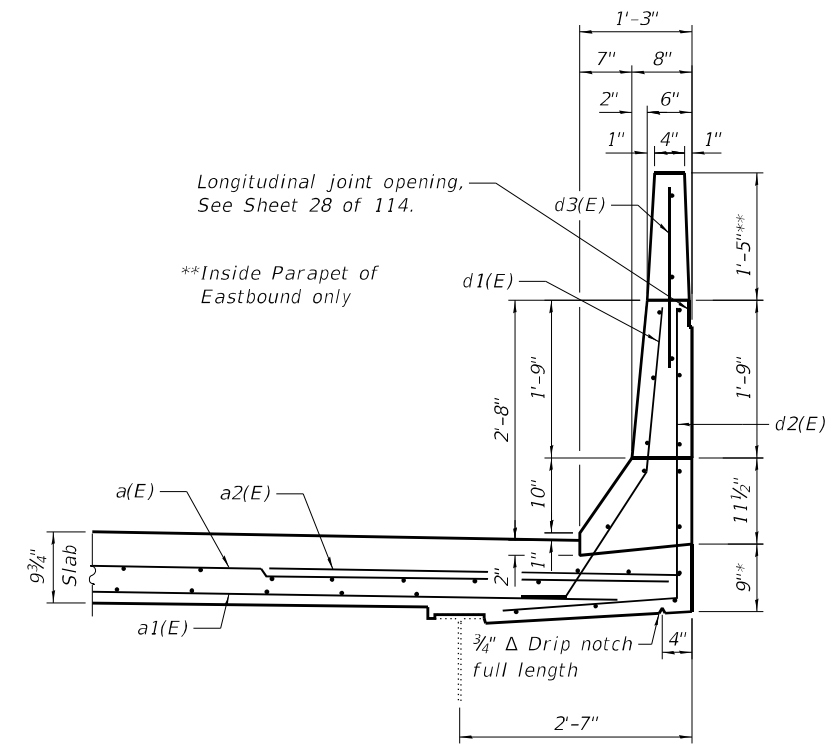

SECTION THRU INSIDE DECK PARAPET
*Adjust to match existing dimensions

Note:
Longitudinal joint opening at inside deck parapet to be formed to match existing dimensions. See Sheet 28 of 114 for additional details.

MODEL: Default
FILE NAME: Z:\1505229_B&O RR Bridge\DCN\Bridg\final\Plot\sheet\0820017-76K02-02-1-joint_Replacement_West_Abutment.dgn
8/13/2024 9:41:35 AM

WJE ENGINEERS ARCHITECTS MATERIAL SCIENTISTS
Wiss, Janney, Elstner Associates, Inc.
330 Pfingsten Road
Northbrook, Illinois 60062
847.272.7400 tel | 847.291.9595 fax

USER NAME = khill	DESIGNED - SMG	REVISED -
PLOT SCALE = 0.1667/1 in.	CHECKED - RAW	REVISED -
PLOT DATE = 8/13/2024	DRAWN - SMG	REVISED -
	CHECKED - RAW	REVISED -

STATE OF ILLINOIS
DEPARTMENT OF TRANSPORTATION

EXPANSION JOINT REPLACEMENT DETAILS (WEST ABUTMENT)
STRUCTURE NO. 082-0017

SHEET 21 OF 114 SHEETS

F.A.I. RTE.	SECTION	COUNTY	TOTAL SHEETS	SHEET NO.
55/70	82-5VB-R-2	ST. CLAIR	254	159
CONTRACT NO. 76K02				
ILLINOIS FED. AID PROJECT				

MODEL: Default
 FILE NAME: Z:\1505229_B&O RR Bridge\DCN\Bridge\final\Plotsheets\0820017-76K02-022-Joint_Replacement-Pier_3_6_7.dgn
 8/13/2024 9:41:36 AM

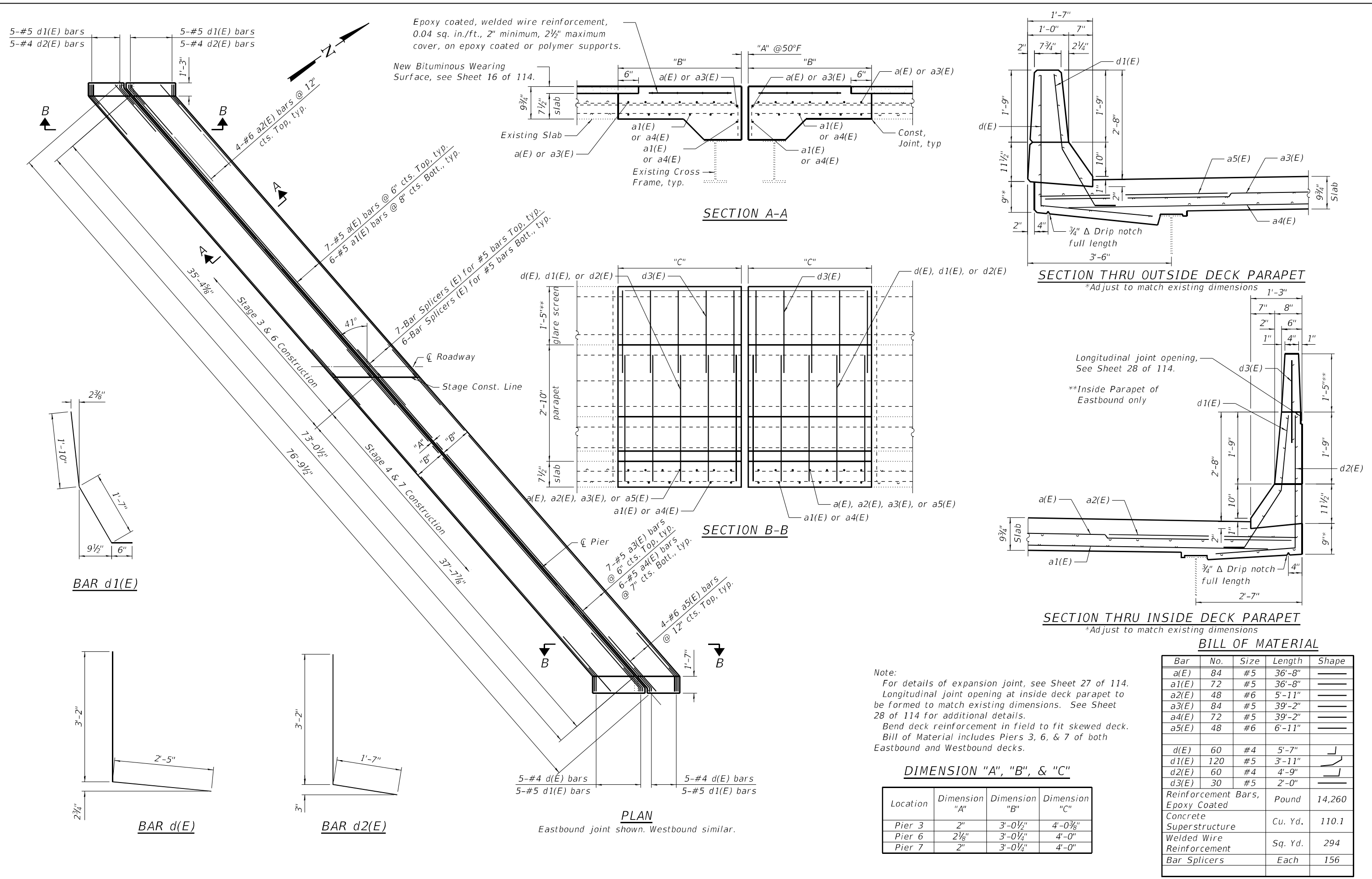

Epoxy coated, welded wire reinforcement, 0.04 sq. in./ft., 2" minimum, 2 1/2" maximum cover, on epoxy coated or polymer supports.

New Bituminous Wearing Surface, see Sheet 16 of 114.

*Adjust to match existing dimensions

**Inside Parapet of Eastbound only

*Adjust to match existing dimensions

Note:
 For details of expansion joint, see Sheet 27 of 114. Longitudinal joint opening at inside deck parapet to be formed to match existing dimensions. See Sheet 28 of 114 for additional details.
 Bend deck reinforcement in field to fit skewed deck.
 Bill of Material includes Piers 3, 6, & 7 of both Eastbound and Westbound decks.

DIMENSION "A", "B", & "C"

Location	Dimension "A"	Dimension "B"	Dimension "C"
Pier 3	2"	3'-0 1/2"	4'-0 3/8"
Pier 6	2 1/8"	3'-0 1/4"	4'-0"
Pier 7	2"	3'-0 1/4"	4'-0"

BILL OF MATERIAL

Bar	No.	Size	Length	Shape
a(E)	84	#5	36'-8"	—
a1(E)	72	#5	36'-8"	—
a2(E)	48	#6	5'-11"	—
a3(E)	84	#5	39'-2"	—
a4(E)	72	#5	39'-2"	—
a5(E)	48	#6	6'-11"	—
d(E)	60	#4	5'-7"	┘
d1(E)	120	#5	3'-11"	┘
d2(E)	60	#4	4'-9"	┘
d3(E)	30	#5	2'-0"	—
Reinforcement Bars, Epoxy Coated		Pound	14,260	
Concrete Superstructure		Cu. Yd.	110.1	
Welded Wire Reinforcement		Sq. Yd.	294	
Bar Splicers		Each	156	

STATE OF ILLINOIS
 DEPARTMENT OF TRANSPORTATION

EXPANSION JOINT REPLACEMENT DETAILS (PIER 3, 6, & 7)
 STRUCTURE NO. 082-0017

F.A.I. RTE.	SECTION	COUNTY	TOTAL SHEETS	SHEET NO.
55/70	82-5VB-R-2	ST. CLAIR	254	160

CONTRACT NO. 76K02
 ILLINOIS FED. AID PROJECT

WJE ENGINEERS ARCHITECTS MATERIAL SCIENTISTS
 Wss, Janney, Elstner Associates, Inc.
 330 Pfingsten Road
 Northbrook, Illinois 60062
 847.272.7400 tel | 847.291.9595 fax

USER NAME	DESIGNED	REVISIONS
= khill	- SMG	-
	- RAW	-
	- SMG	-
	- RAW	-

PLOT SCALE = 0.1667"/in.
 DRAWN - SMG
 CHECKED - RAW
 PLOT DATE = 8/13/2024

Epoxy coated, welded wire reinforcement, 0.04 sq. in./ft., 2" minimum, 2 1/2" maximum cover, on epoxy coated or polymer supports.

New Bituminous Wearing Surface, see Sheet 16 of 114.

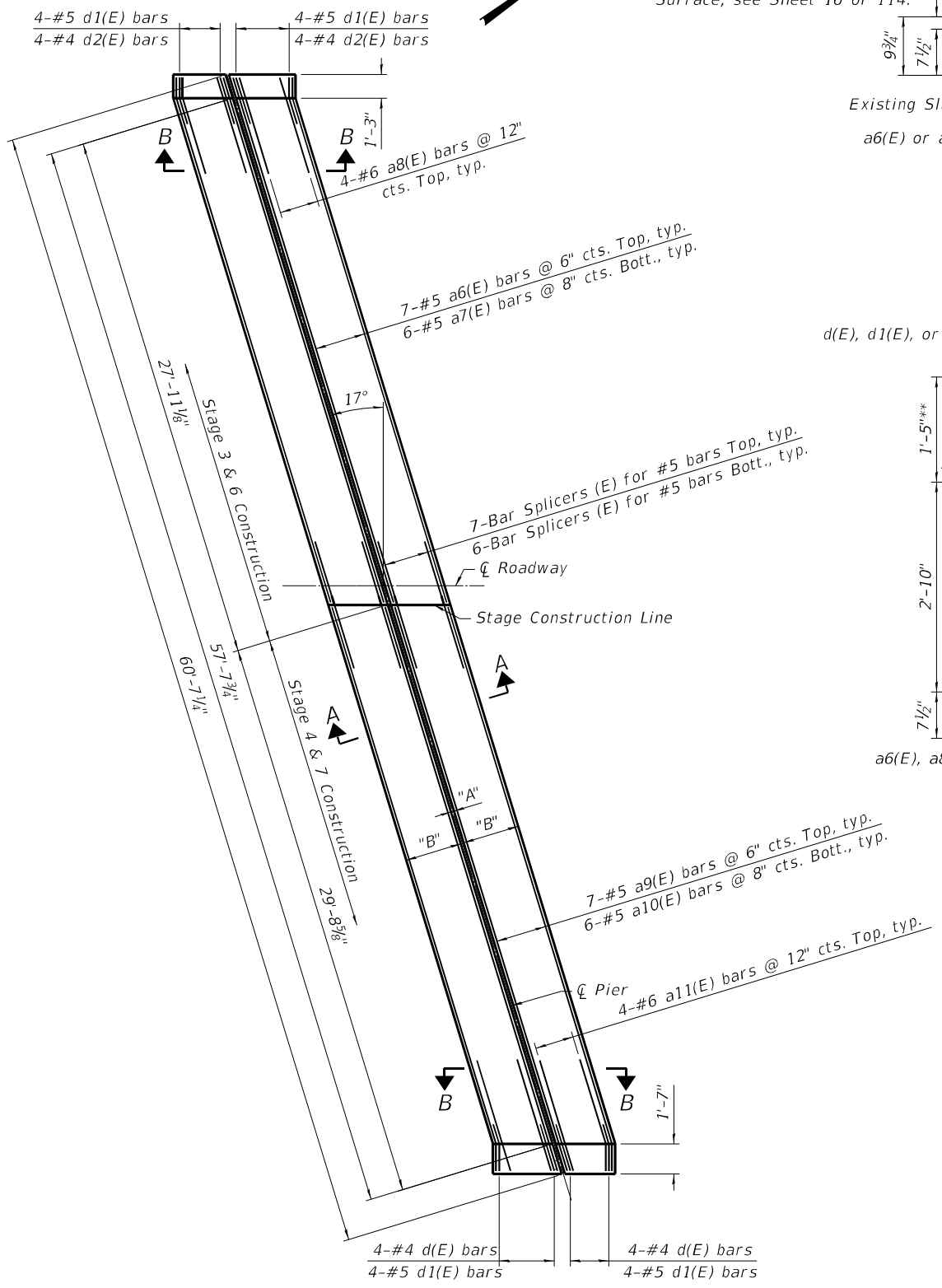

PLAN
Eastbound joint shown. Westbound similar.

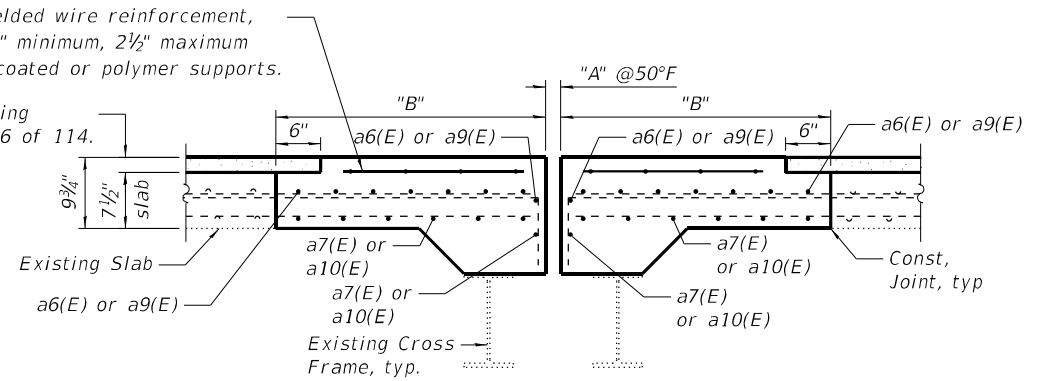

SECTION A-A

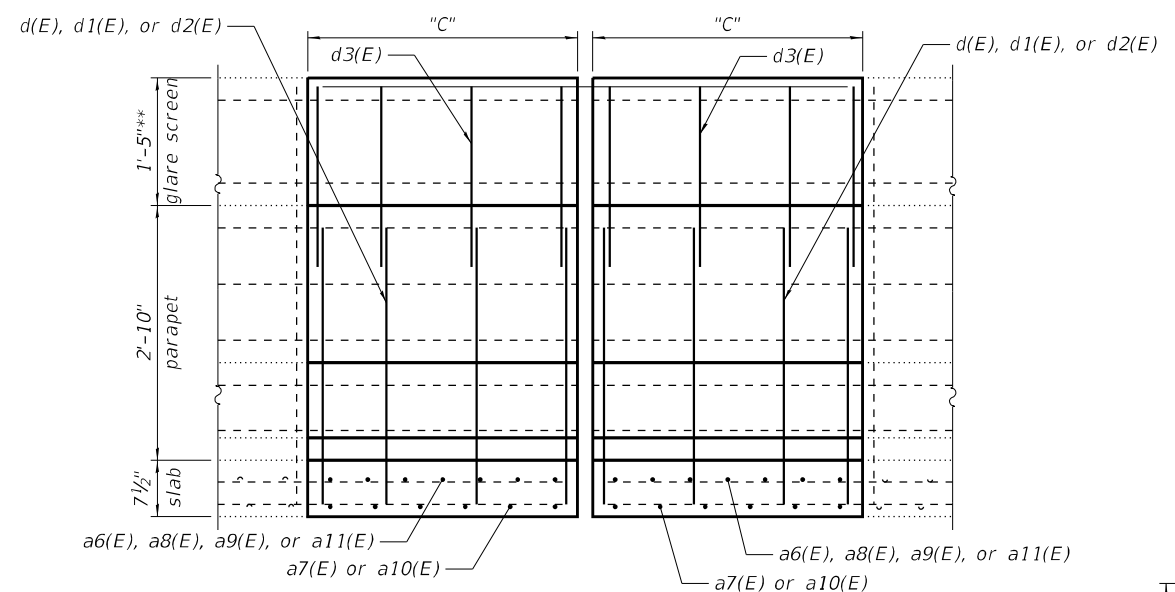

SECTION B-B

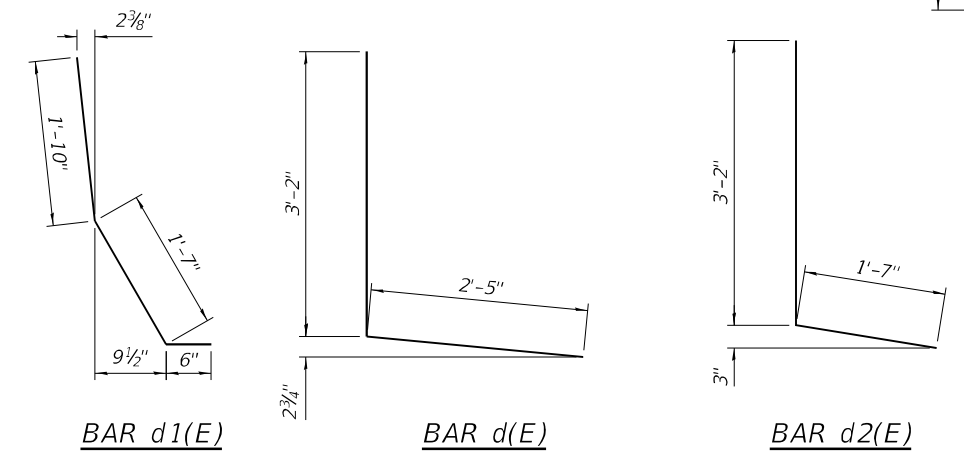

DIMENSION "A", "B", & "C"

Location	Dimension "A"	Dimension "B"	Dimension "C"
Pier 8	2"	3'-0 1/2"	3'-2 1/8"
Pier 9	2"	3'-0 1/4"	3'-1 7/8"

Note:
For details of expansion joint, see Sheet 27 of 114.
Longitudinal joint opening at inside deck parapet to be formed to match existing dimensions. See Sheet 28 of 114 for additional details.
Bend deck reinforcement in field to fit skewed deck.
Bill of Material includes Piers 8 & 9 of both Eastbound and Westbound decks.

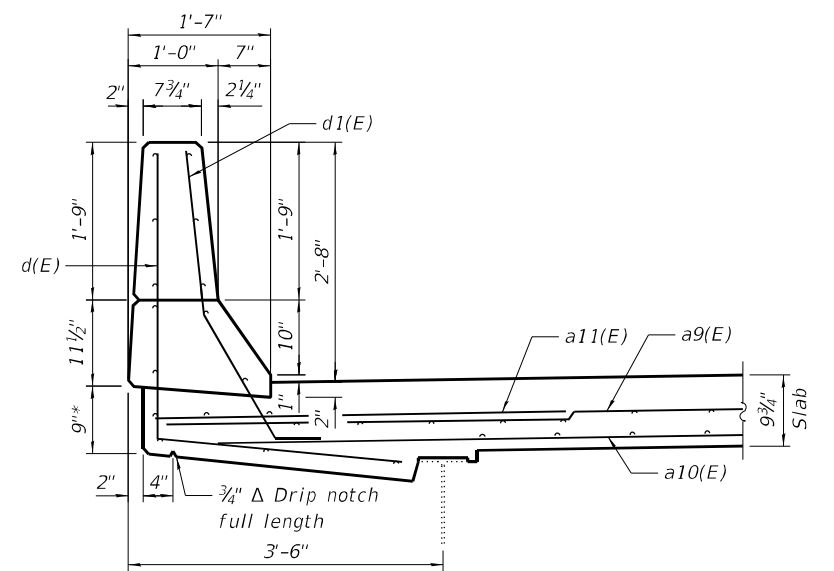

SECTION THRU OUTSIDE DECK PARAPET

*Adjust to match existing dimensions

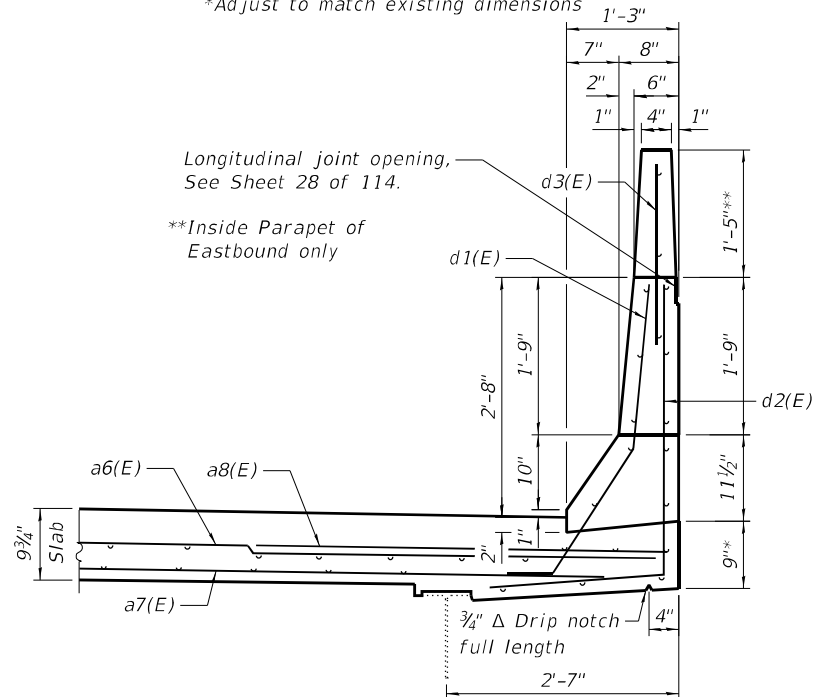

SECTION THRU INSIDE DECK PARAPET

*Adjust to match existing dimensions

BILL OF MATERIAL

Bar	No.	Size	Length	Shape
a6(E)	56	#5	28'-11"	—
a7(E)	48	#5	28'-11"	—
a8(E)	32	#6	5'-3"	—
a9(E)	56	#5	30'-11"	—
a10(E)	48	#5	30'-11"	—
a11(E)	32	#6	6'-1"	—
d(E)	32	#4	5'-7"	┘
d1(E)	64	#5	3'-11"	┘
d2(E)	32	#4	4'-9"	┘
d3(E)	16	#5	2'-0"	—
Reinforcement Bars, Epoxy Coated		Pound	7,560	
Concrete Superstructure		Cu. Yd.	58.2	
Welded Wire Reinforcement		Sq. Yd.	154	
Bar Splicers		Each	104	

MODEL: Default
FILE NAME: Z:\1505229_B&O_RR Bridge\DCN\Bridg\final\Plotsheets\082001776K02-023-Joint_Replacement-Pier 8 & 9.dgn

WJE ENGINEERS ARCHITECTS MATERIAL SCIENTISTS
Wiss, Janney, Elstner Associates, Inc.
330 Pfingsten Road
Northbrook, Illinois 60062
847.272.7400 tel | 847.291.9595 fax

USER NAME = khill	DESIGNED - SMG	REVISED -
PLOT SCALE = 0.1667"/in.	CHECKED - RAW	REVISED -
PLOT DATE = 8/13/2024	DRAWN - SMG	REVISED -
	CHECKED - RAW	REVISED -

**STATE OF ILLINOIS
DEPARTMENT OF TRANSPORTATION**

**EXPANSION JOINT REPLACEMENT DETAILS (PIER 8 & 9)
STRUCTURE NO. 082-0017**

SHEET 23 OF 114 SHEETS

F.A.I. RTE.	SECTION	COUNTY	TOTAL SHEETS	SHEET NO.
55/70	82-5VB-R-2	ST. CLAIR	254	161
CONTRACT NO. 76K02				
ILLINOIS FED. AID PROJECT				

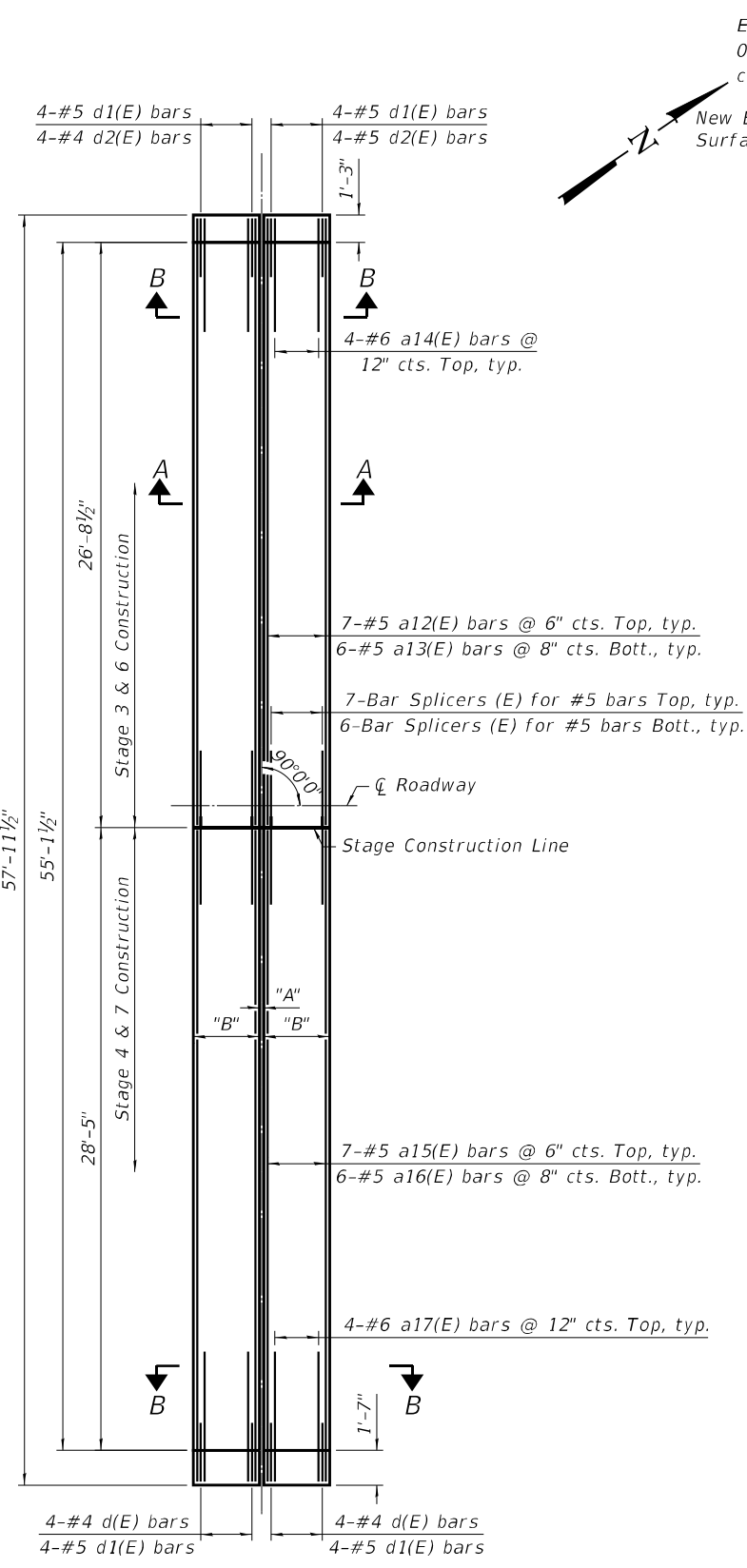

PLAN
Eastbound joint shown. Westbound similar.

Epoxy coated, welded wire reinforcement, 0.04 sq. in./ft., 2" minimum, 2 1/2" maximum cover, on epoxy coated or polymer supports.

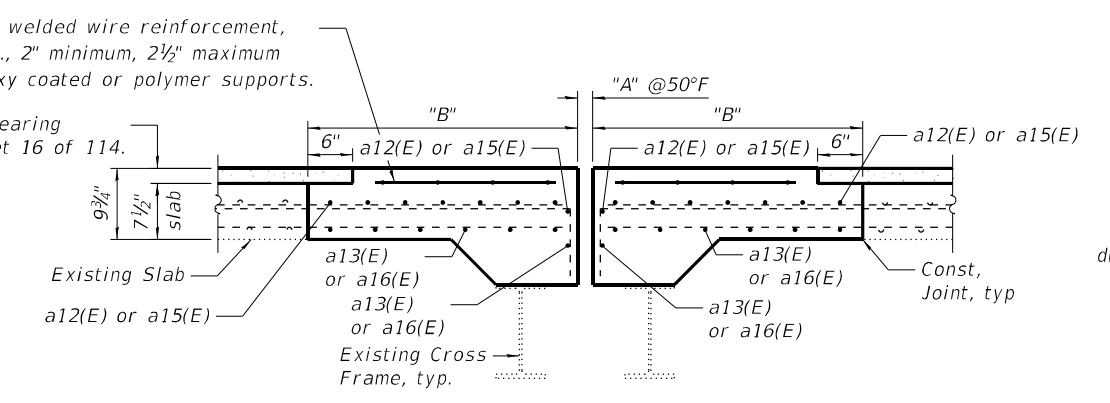

SECTION A-A

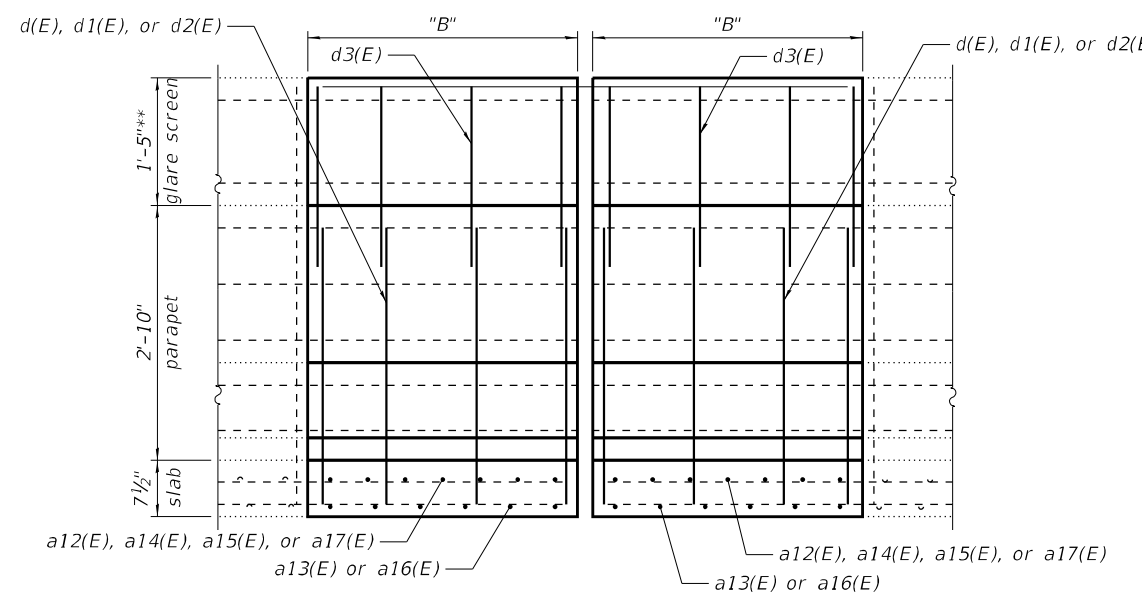

SECTION B-B

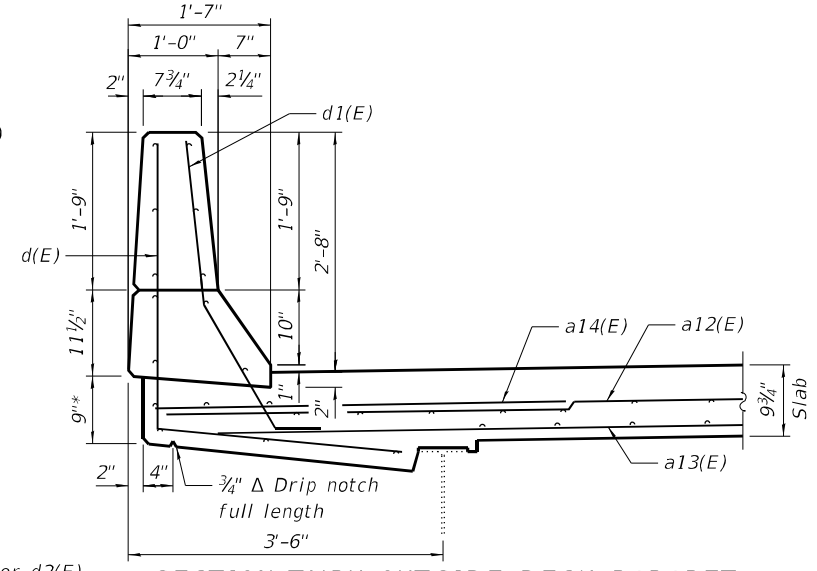

SECTION THRU OUTSIDE DECK PARAPET
*Adjust to match existing dimensions

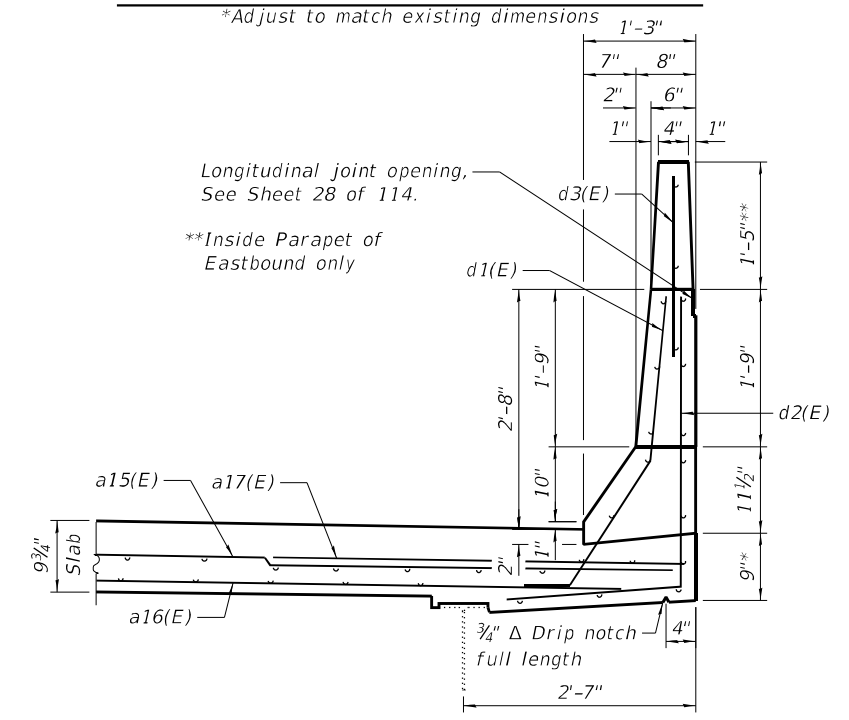

SECTION THRU INSIDE DECK PARAPET
*Adjust to match existing dimensions

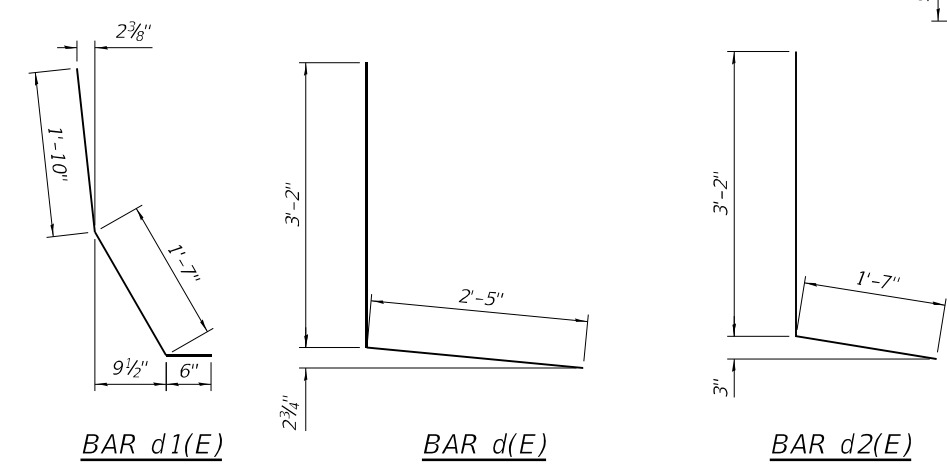

BAR d1(E)

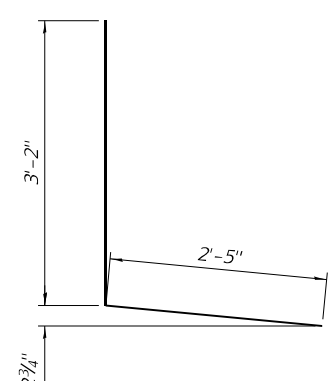

BAR d(E)

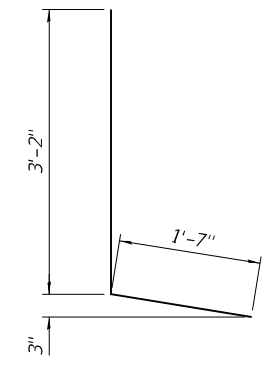

BAR d2(E)

DIMENSION "A" and "B"

Location	Dimension "A"	Dimension "B"
Pier 10	2"	3'-0"
Pier 13	2 1/2"	2'-11 1/2"
Pier 16	2 1/2"	2'-11 3/4"

Note:
For details of expansion joint, see Sheet 27 of 114.
Longitudinal joint opening at inside deck parapet to be formed to match existing dimensions. See Sheet 28 of 114 for additional details.
Bend deck reinforcement in field to fit skewed deck.
Bill of Material includes Piers 10, 13, & 16 of both Eastbound and Westbound decks.

BILL OF MATERIAL

Bar	No.	Size	Length	Shape
a12(E)	84	#5	27'-8"	—
a13(E)	72	#5	27'-8"	—
a14(E)	48	#6	5'-2"	—
a15(E)	84	#5	29'-7"	—
a16(E)	72	#5	29'-7"	—
a17(E)	48	#6	5'-11"	—
d(E)	48	#4	5'-7"	┘
d1(E)	96	#5	3'-11"	┘
d2(E)	48	#4	4'-9"	┘
d3(E)	24	#5	2'-0"	—
Reinforcement Bars, Epoxy Coated		Pound	10,910	
Concrete Superstructure		Cu. Yd.	83.4	
Welded Wire Reinforcement		Sq. Yd.	222	
Bar Splicers		Each	156	

MODEL: Default
FILE NAME: Z:\1505229_B&O_RR_Bridge\DCN\Bridg\final\Plotsheets\0820017-76K02-024-Joint_Replacement-Pier_10_13_&_16.dgn

WJE ENGINEERS ARCHITECTS MATERIAL SCIENTISTS
Wiss, Janney, Elstner Associates, Inc.
330 Pfingsten Road
Northbrook, Illinois 60062
847.272.7400 tel | 847.291.9595 fax

USER NAME = khill	DESIGNED - SMG	REVISED -
PLOT SCALE = 0.1667"/in.	CHECKED - RAW	REVISED -
PLOT DATE = 8/13/2024	DRAWN - SMG	REVISED -
	CHECKED - RAW	REVISED -

STATE OF ILLINOIS
DEPARTMENT OF TRANSPORTATION

EXPANSION JOINT REPLACEMENT DETAILS (PIER 10, 13, & 16)
STRUCTURE NO. 082-0017

SHEET 24 OF 114 SHEETS

F.A.I. RTE.	SECTION	COUNTY	TOTAL SHEETS	SHEET NO.
55/70	82-5VB-R-2	ST. CLAIR	254	162
CONTRACT NO. 76K02				
ILLINOIS FED. AID PROJECT				

MODEL: Default
 FILE NAME: Z:\15052529_B&O_RR_Bridge\DCN\Bridg\final\Plotsheets\0820017-76K02-025-Joint_Replace\East_Abutment.dgn
 WJE ENGINEERS ARCHITECTS MATERIAL SCIENTISTS
 Wss, Janney, Elstner Associates, Inc.
 330 Pfingsten Road
 Northbrook, Illinois 60062
 847.272.7400 tel | 847.291.9595 fax

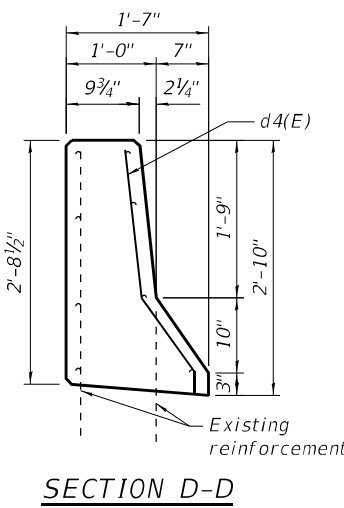
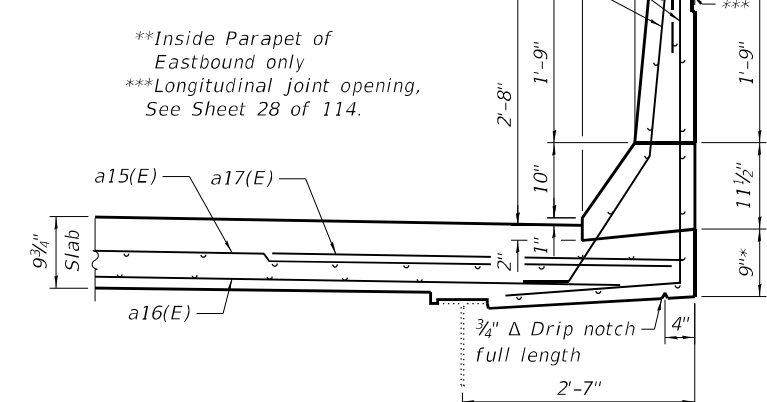
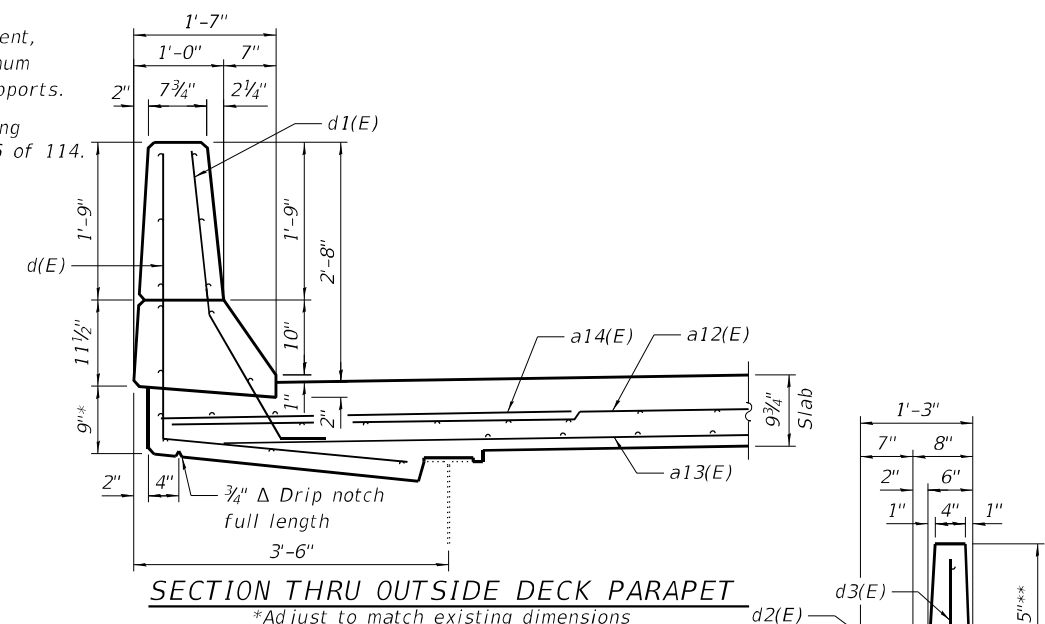
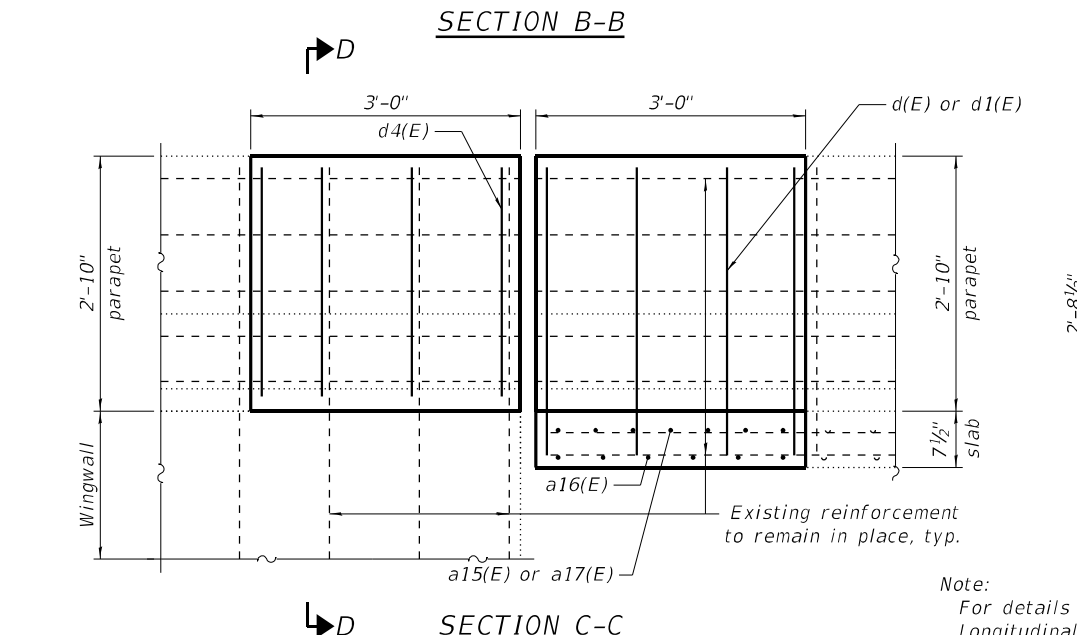
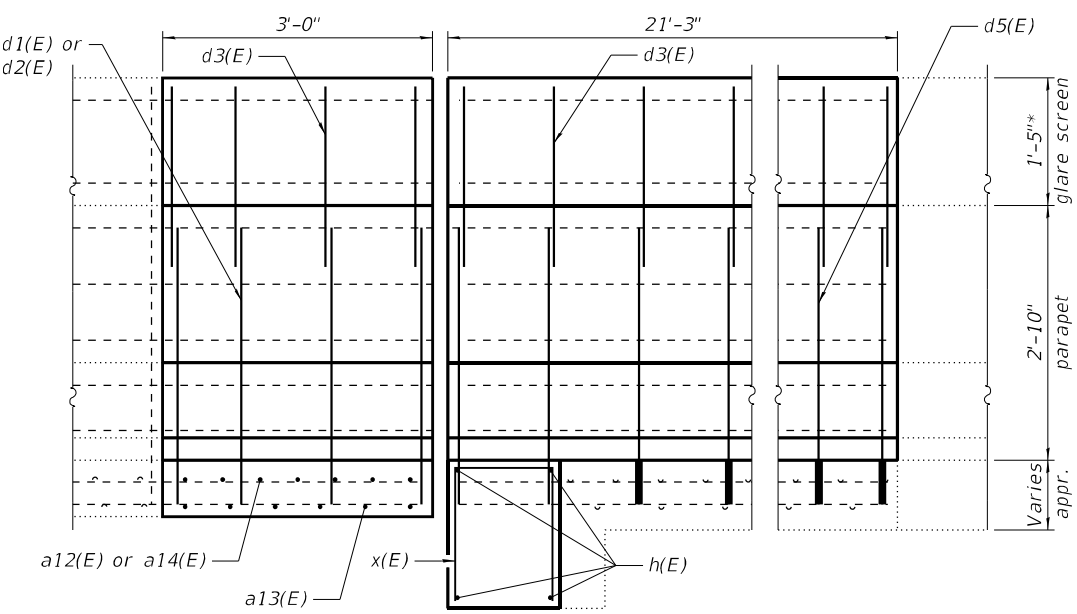
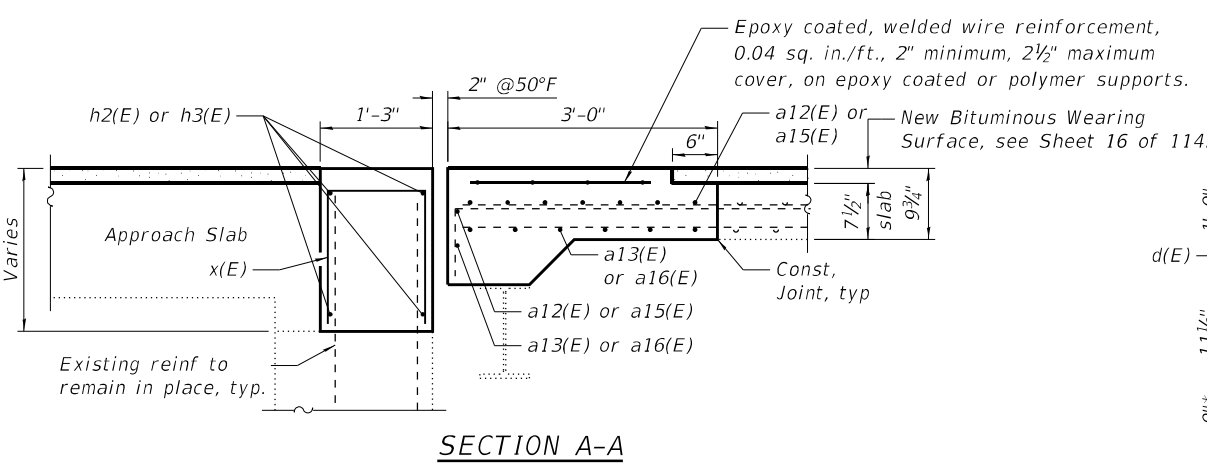
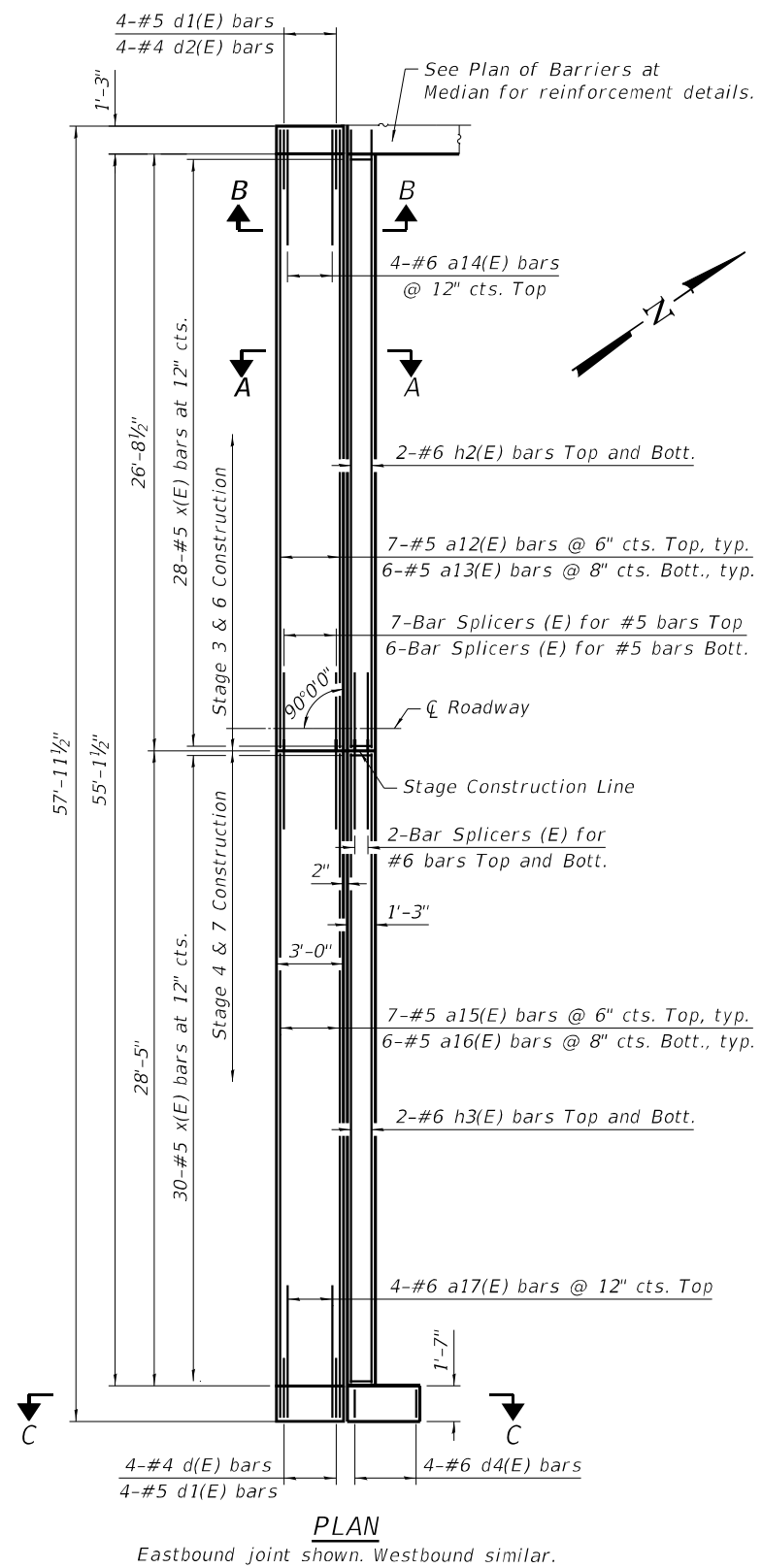

**Inside Parapet of Eastbound only
 ***Longitudinal joint opening, See Sheet 28 of 114.

Note:
 For details of expansion joint, see Sheet 27 of 114.
 Longitudinal joint opening in inside deck parapets to be formed to match existing dimensions. See Sheet 28 of 114 for additional details.
 Bill of Material includes Eastbound and Westbound decks.
 Incorporate existing wingwall reinforcement into new construction.

BILL OF MATERIAL

Bar	No.	Size	Length	Shape
a12(E)	14	#5	27'-8"	—
a13(E)	12	#5	27'-8"	—
a14(E)	8	#6	5'-2"	—
a15(E)	14	#5	29'-7"	—
a16(E)	12	#5	29'-7"	—
a17(E)	8	#6	5'-11"	—
h2(E)	8	#6	27'-8"	—
h3(E)	8	#6	29'-7"	—
d(E)	8	#4	5'-7"	┘
d1(E)	16	#5	3'-11"	┘
d2(E)	8	#4	4'-9"	┘
d3(E)	26	#5	2'-0"	—
d4(E)	8	#6	2'-11"	┘
d5(E)	44	#4	3'-5"	—
e2(E)	13	#5	20'-11"	—
x(E)	116	#5	3'-6"	┘
Reinforcement Bars, Epoxy Coated		Pound	3,390	
Concrete Superstructure		Cu. Yd.	27.0	
Welded Wire Reinforcement		Sq. Yd.	38	
Bar Splicers		Each	34	

STATE OF ILLINOIS
 DEPARTMENT OF TRANSPORTATION

EXPANSION JOINT REPLACEMENT DETAILS (EAST ABUTMENT)
 STRUCTURE NO. 082-0017

F.A.I. RTE.	SECTION	COUNTY	TOTAL SHEETS	SHEET NO.
55/70	82-5VB-R-2	ST. CLAIR	254	163

CONTRACT NO. 76K02

SHEET 25 OF 114 SHEETS

ILLINOIS FED. AID PROJECT

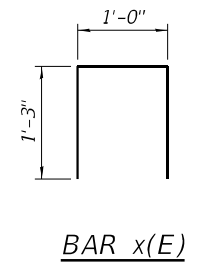
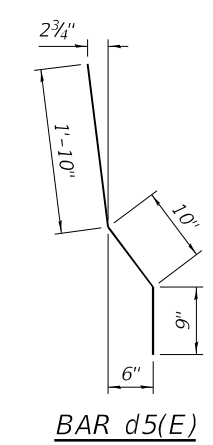
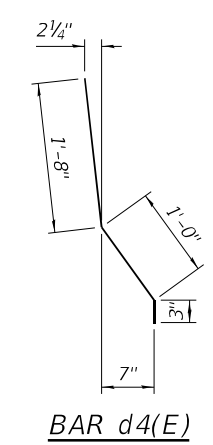
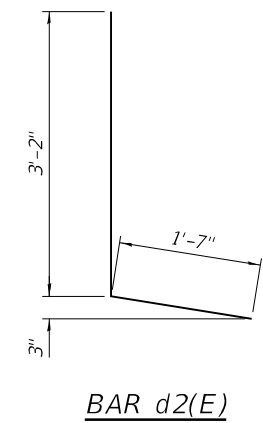
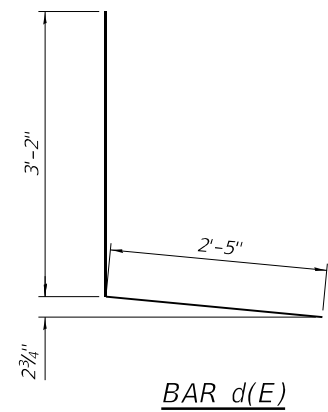
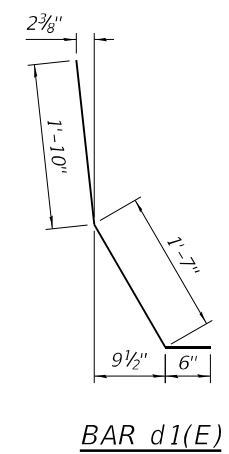
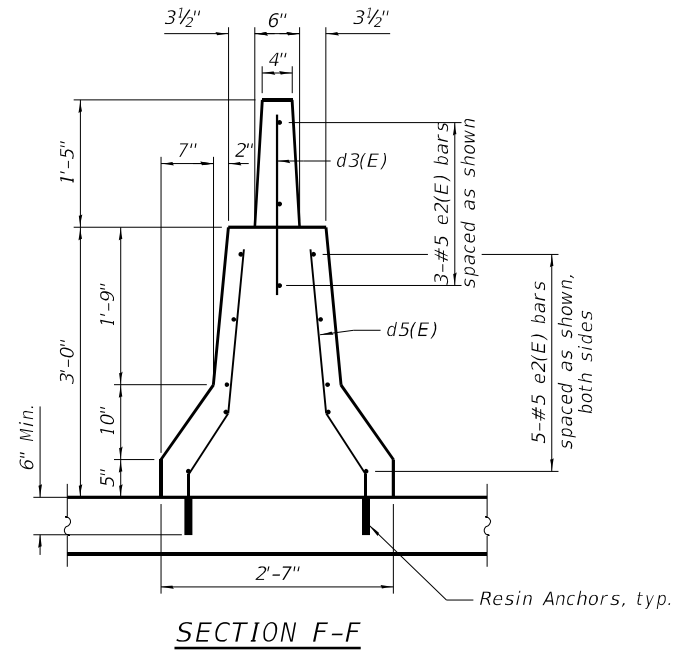
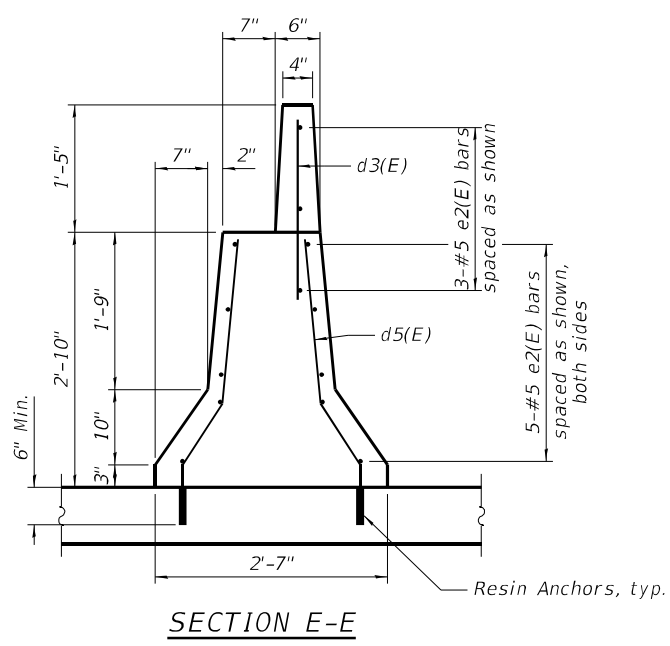
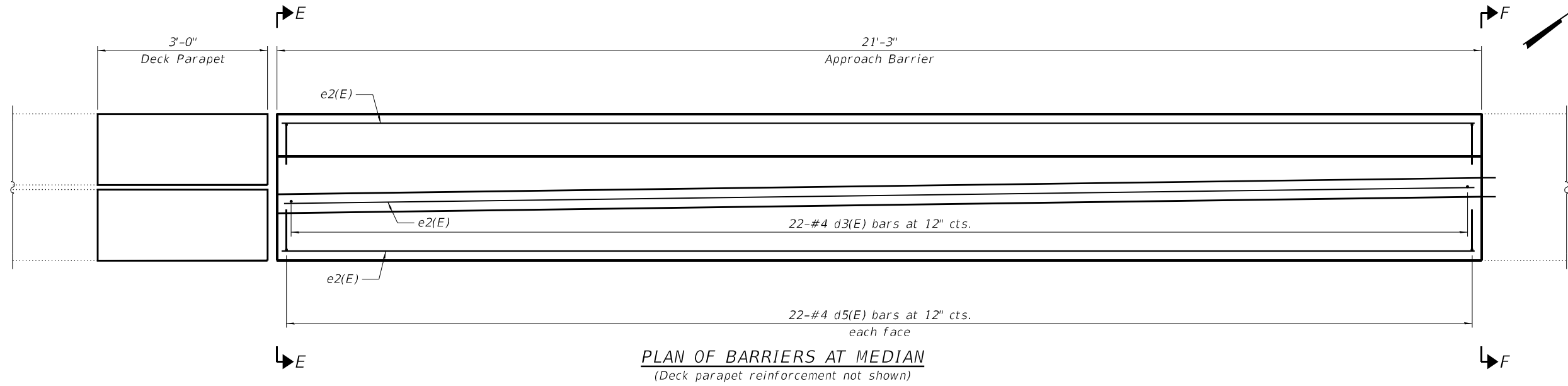

STATE OF ILLINOIS
DEPARTMENT OF TRANSPORTATION

EXPANSION JOINT REPLACEMENT DETAILS (EAST ABUTMENT)
STRUCTURE NO. 082-0017

F.A.I. RTE.	SECTION	COUNTY	TOTAL SHEETS	SHEET NO.
55/70	82-5VB-R-2	ST. CLAIR	254	164
CONTRACT NO. 76K02				
ILLINOIS FED. AID PROJECT				

MODEL: Default
FILE NAME: Z:\1505229_B&O_RR_Bridge\DCN\Bridg\final\Plotsheets\0820017-76K02-026-01nL_Replacement_East_Abutment.dgn

WJE ENGINEERS ARCHITECTS MATERIAL SCIENTISTS
Wiss, Janney, Elstner Associates, Inc.
330 Pfingsten Road
Northbrook, Illinois 60062
847.272.7400 tel | 847.291.9595 fax
www.wje.com

USER NAME = khill
DESIGNED - SMG
CHECKED - RAW
PLOT SCALE = 0.1667"/in.
DRAWN - SMG
PLOT DATE = 8/13/2024
CHECKED - RAW

DESIGNED - SMG
CHECKED - RAW
DRAWN - SMG
PLOT DATE = 8/13/2024
CHECKED - RAW

REVISED -
REVISED -
REVISED -
REVISED -

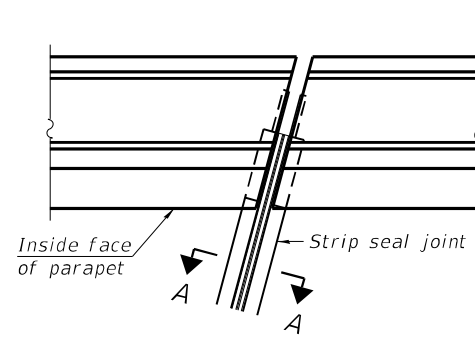

FOR SKEWS $\leq 30^\circ$

PLAN AT PARAPET

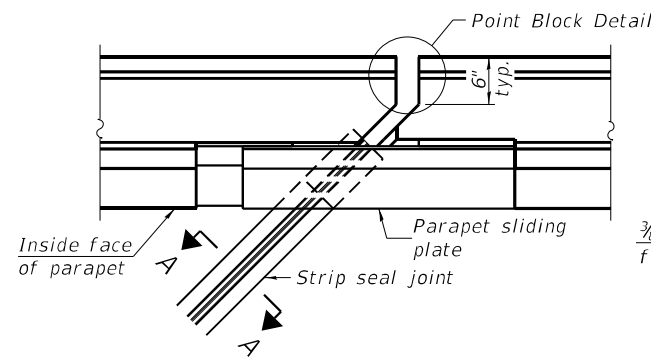

FOR SKEWS $> 30^\circ$

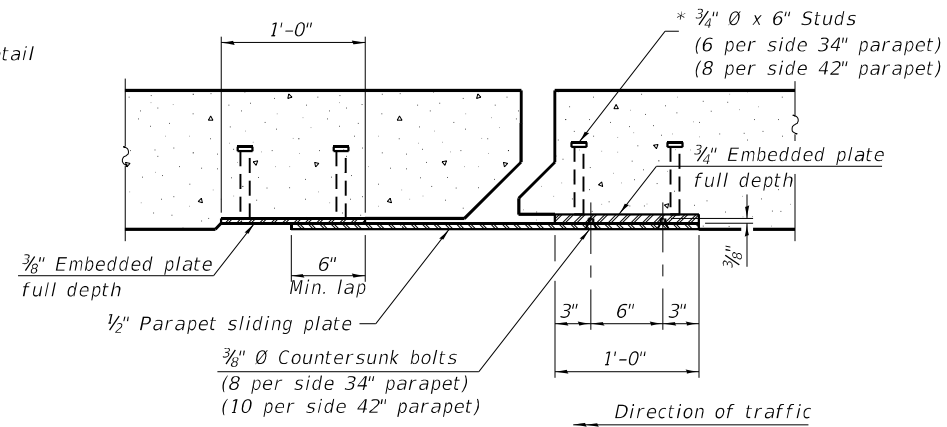

SECTION B-B

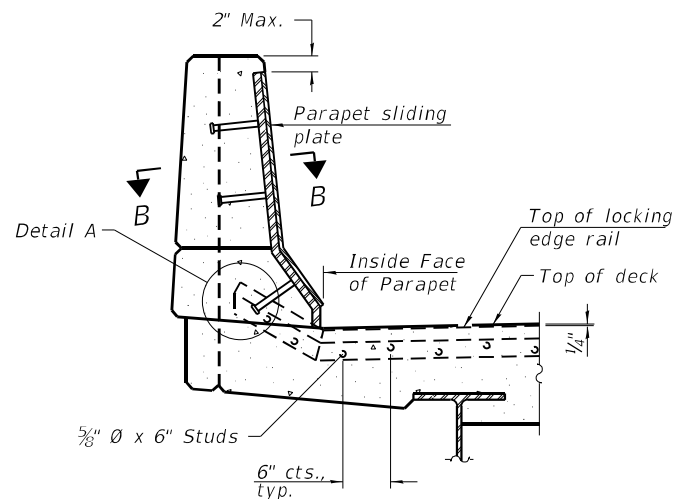

ELEVATION AT PARAPET

(Skews $> 30^\circ$ shown. Skews $\leq 30^\circ$ similar except as shown in plan view.)

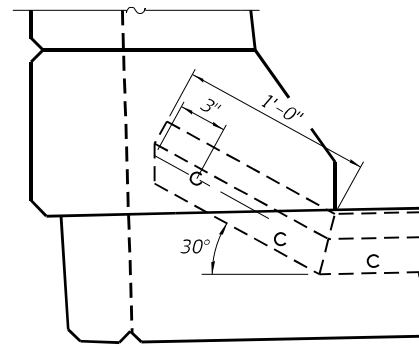

DETAIL A

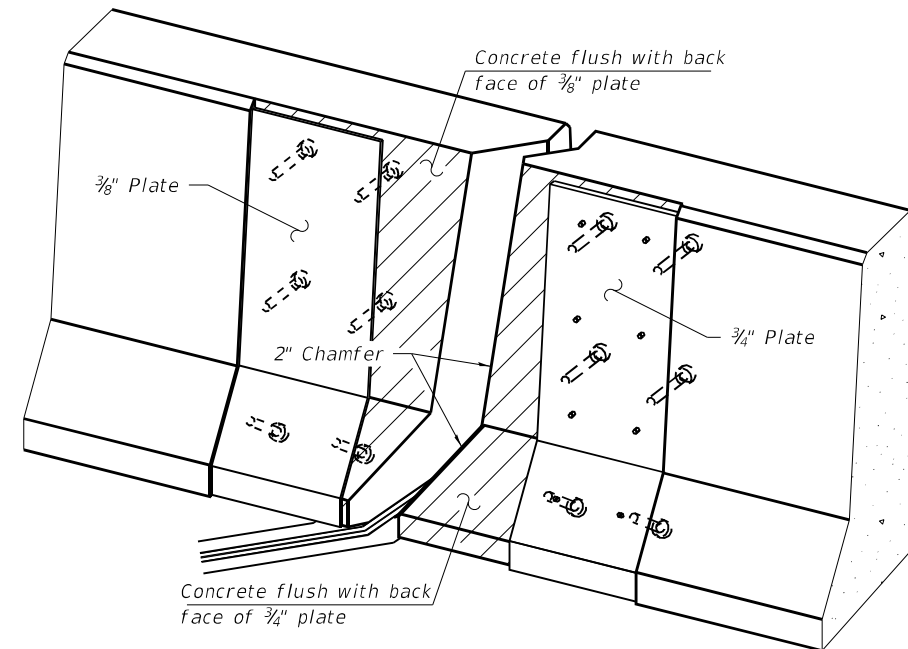

TRIMETRIC VIEW
(Showing embedded plates only)

Notes:

The strip seal shall be made continuous and shall have a minimum thickness of 1/4". The configuration of the strip seal shall match the configuration of the locking edge rails. Open or "webbed" strip seal gland configurations are not permitted. The gland shall be sized for a maximum rated movement of 4 inches.

The locking edge rails depicted are configured for typical applications and are conceptual only. The actual configuration of the locking edge rails and matching strip seal may vary from manufacturer to manufacturer provided they fit the application and meet the minimum anchorage shown. Flanged edge rails, however, will not be allowed. Locking edge rails may exceed the 4 1/2" maximum depth provided the anchorage system is revised according to the manufacturer's recommendation.

The manufacturer's recommended installation methods shall be followed.

All steel components shall be galvanized after fabrication according to Article 520.03 of the Standard Specifications.

The Maximum space between locking edge rail segments shall be 3/16" and sealed with a suitable sealant; however, any rail joint within 10' measured perpendicular to the face of the curb or parapet shall be welded as shown in the locking edge rail splice detail.

Cost of parapet sliding plates, embedded plates, and anchorage studs included with Preformed Joint Strip Seal.

34" F-shape barrier shown, 42" F-shape similar as noted.

The concrete opening below the strip seal will vary based on the locking edge rail chosen by the Contractor. Deck and parapet lengths shown elsewhere in the plans are dimensioned to the concrete opening, not the joint opening, and are based on the rolled locking edge rail. If the Contractor elects to use a different locking edge rail, dimensional adjustments may be required. One exception to this would be the strip seal joint at the end of the precast bridge approach slab. For these cases the pavement connector length shall be adjusted, not the length of the bridge approach slab.

EXPANSION OPENINGS

Pier	"A"	"B"
W. Abut.	1 1/2"	2"
Pier 3	1 1/2"	2"
Pier 6	1 3/8"	2 1/8"
Pier 7	1 1/2"	2"
Pier 8	1 1/2"	2"
Pier 9	1 1/2"	2"
Pier 10	1 1/2"	2"
Pier 13	2"	2 1/2"
Pier 16	2"	2 1/2"
E. Abut.	1 1/2"	2"

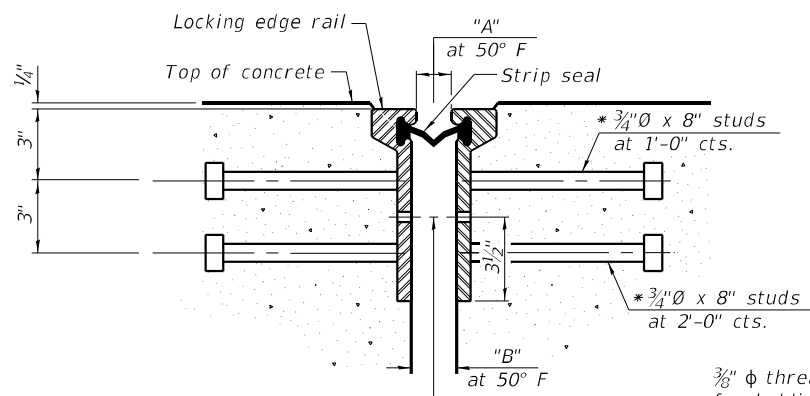

SHOWING ROLLED RAIL JOINT

3/8" ϕ threaded rods in 7/16" ϕ holes at $\pm 4'-0"$ cts. for holding the proper joint opening based on the temperature during the deck pour. Place to miss studs. All rods shall be burned, or sawed off flush with the plates after concrete is set.

SECTION A-A

* Granular or solid flux filled headed studs conforming to Article 1006.32 of the Std. Specs., automatically end welded.

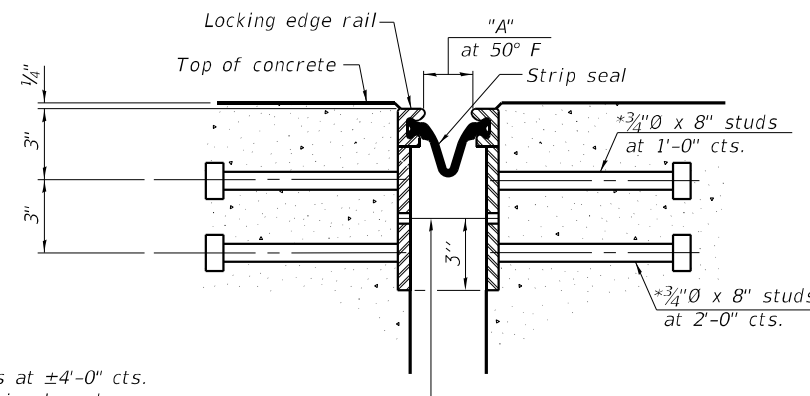

SHOWING WELDED RAIL JOINT

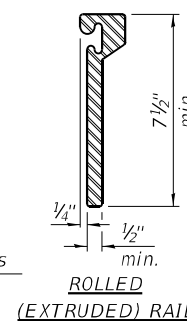

ROLLED (EXTRUDED) RAIL

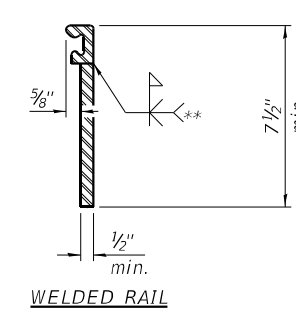

WELDED RAIL

LOCKING EDGE RAILS

** Back gouge not required if complete joint penetration is verified by mock-up.

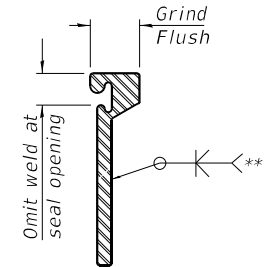

LOCKING EDGE RAIL SPLICE

The inside of the locking edge rail groove shall be free of weld residue. Rolled rail shown, welded rail similar.

BILL OF MATERIAL

Item	Unit	Total
Preformed Joint Strip Seal	Foot	1,296

EJ-SS (TALL WITH GUTTER) 10-1-19

STATE OF ILLINOIS
DEPARTMENT OF TRANSPORTATION

PREFORMED JOINT STRIP SEAL
STRUCTURE NO. 082-0017

SHEET 27 OF 114 SHEETS

F.A.I. RTE.	SECTION	COUNTY	TOTAL SHEETS	SHEET NO.
55/70	82-5VB-R-2	ST. CLAIR	254	165

CONTRACT NO. 76K02

ILLINOIS FED. AID PROJECT

MODEL: Default FILE NAME: Z:\1505229_B&O_RR_Bridge\DNV\Bridges\0820017-76K02-027-Strip_Seal_Joint.dgn

WJE ENGINEERS ARCHITECTS MATERIAL SCIENTISTS
Wiss, Janney, Elstner Associates, Inc.
330 Pfingsten Road
Northbrook, Illinois 60062
847.272.7400 tel | 847.291.9595 fax

USER NAME = khill
DESIGNED - SMG
CHECKED - RAW
PLOT SCALE = 0.1667/1 in.
DRAWN - SMG
PLOT DATE = 8/13/2024
CHECKED - RAW
REVISED -

REVISED -
REVISED -
REVISED -
REVISED -

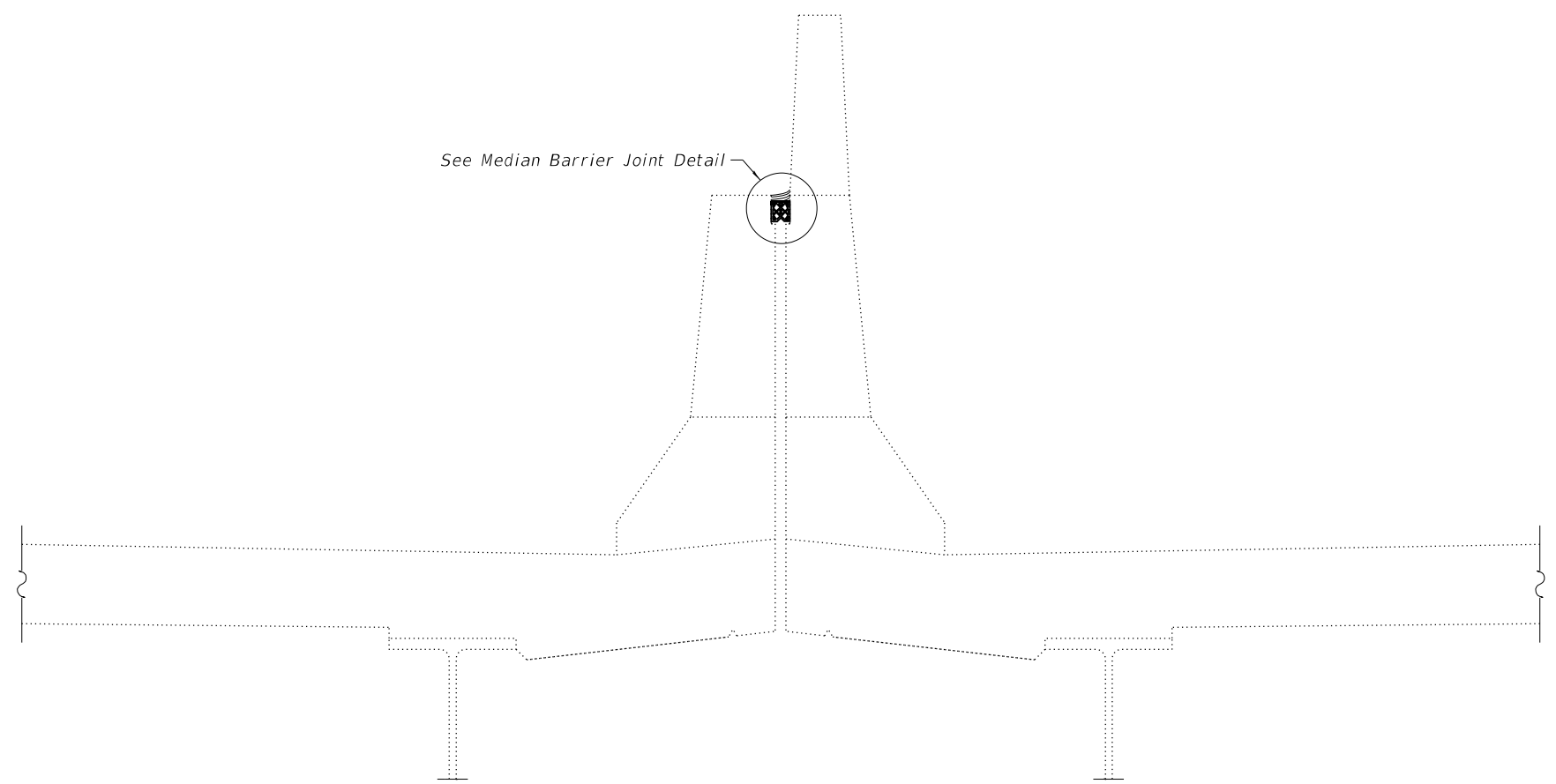

See Median Barrier Joint Detail

SECTION THRU PARAPET AT MEDIAN

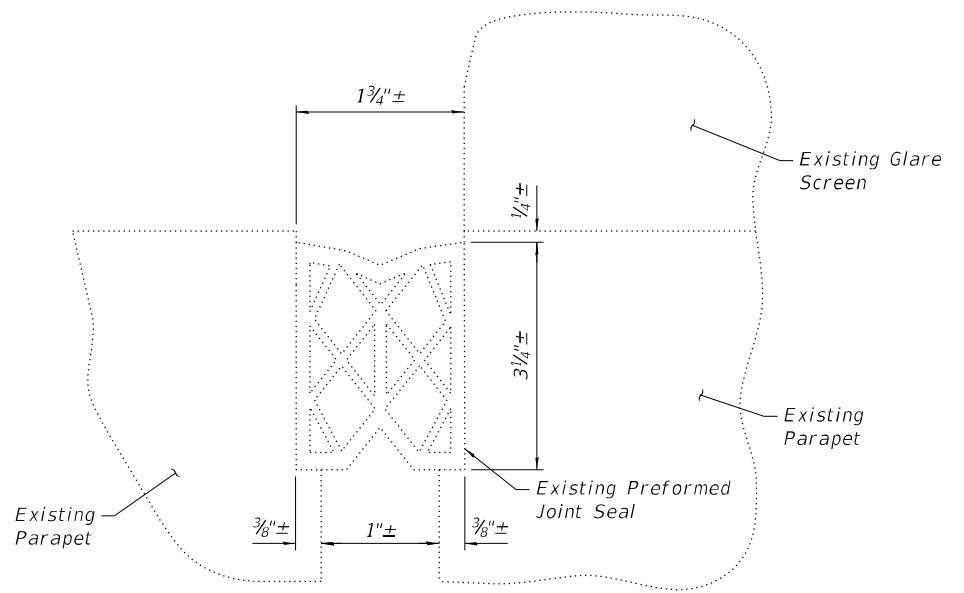

DETAILS OF EXISTING JOINT OPENING

- Notes:
1. Dimensions shown for existing joint are based on previous rehabilitation drawings. Actual dimensions and condition of the joint may vary.
 2. Manufacturer to verify that proposed preformed joint seal system is compliant with existing conditions.
 3. Surface preparation and installation means and methods for installation of new seal system included in Preformed Joint Seal.

Note:
 Median joint seal to be repaired. See Sheet 7 of 114 for staging details
 See Sheet 16 of 114 for parapet joint sealant repairs.

- Parapet Repair Procedure:
1. Remove existing Preformed Joint Seal and Polyurethane Sealant.
 2. Perform Structural Repair of Concrete to parapet and glare screen.
 3. Clean all joint seal bonding surfaces. Prepare recess at median barrier to receive new joint seal system.
 4. Install new Preformed Joint Sealant at median. Bond preformed joint seal to concrete, as directed by manufacturer.
 5. Install new Polyurethane Joint Sealant over Preformed Joint Sealant at Median Barrier.

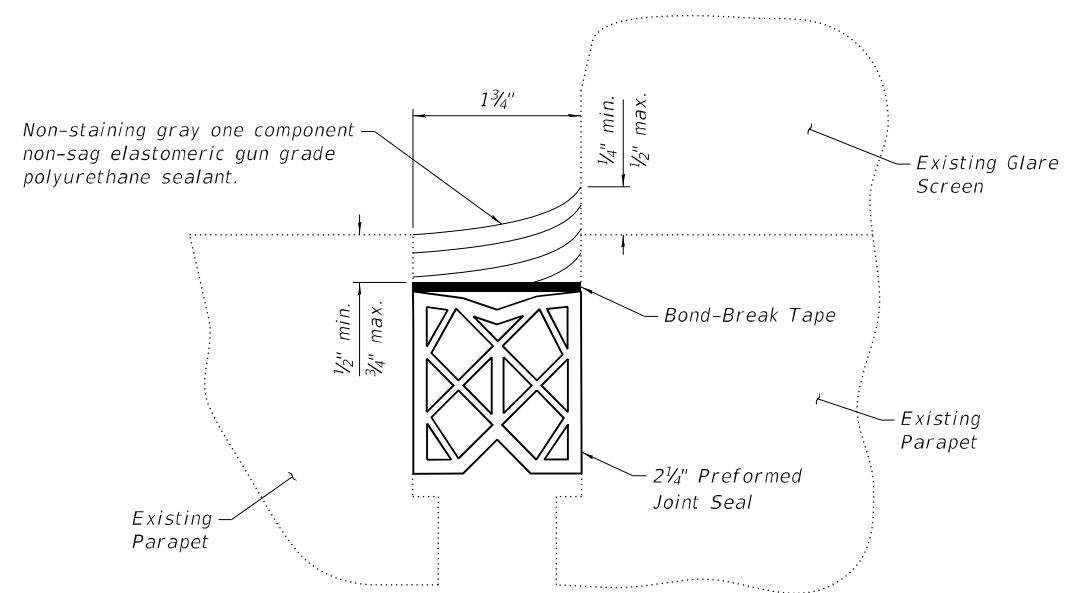

MEDIAN BARRIER JOINT DETAIL

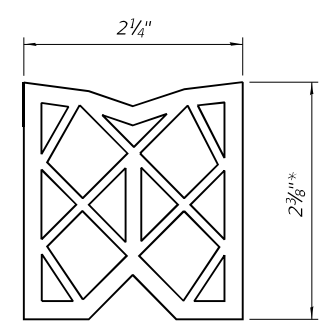

PREFORMED JOINT SEAL 2 1/4"

*Dimensions may vary with manufacturer

BILL OF MATERIAL

ITEM	UNIT	QUANTITY
Polyurethane Sealant	Foot	1655
Preformed Joint Seal 2 1/4"	Foot	1655

MODEL: Default
 FILE NAME: Z:\1505229_B&O_RR_Bridge\DCN\Bridg\final\Plotsheets\0820017-76K02-028-Longitudinal_Joint.dgn

WJE ENGINEERS ARCHITECTS MATERIAL SCIENTISTS
 Wss, Janney, Elstner Associates, Inc.
 330 Pfingsten Road
 Northbrook, Illinois 60062
 847.272.7400 tel | 847.291.9595 fax
 www.wje.com

USER NAME = khill	DESIGNED - SMG	REVISED -
PLOT SCALE = 0.1667"/in.	CHECKED - RAW	REVISED -
PLOT DATE = 8/13/2024	DRAWN - SMG	REVISED -
	CHECKED - RAW	REVISED -

**STATE OF ILLINOIS
 DEPARTMENT OF TRANSPORTATION**

**LONGITUDINAL JOINT DETAILS
 STRUCTURE NO. 082-0017**

SHEET 28 OF 114 SHEETS

F.A.I. RTE.	SECTION	COUNTY	TOTAL SHEETS	SHEET NO.
55/70	82-5VB-R-2	ST. CLAIR	254	166
CONTRACT NO. 76K02				
		ILLINOIS	FED. AID PROJECT	

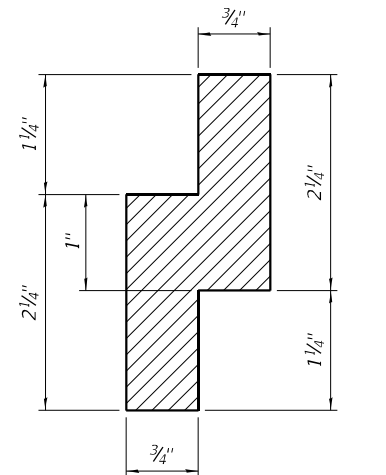
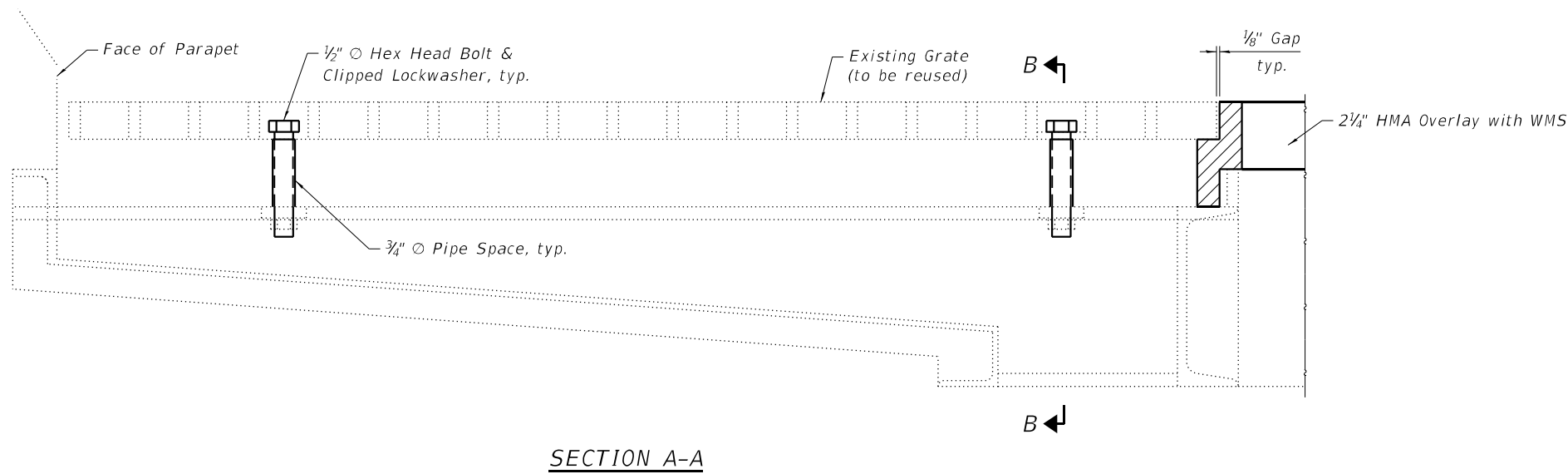
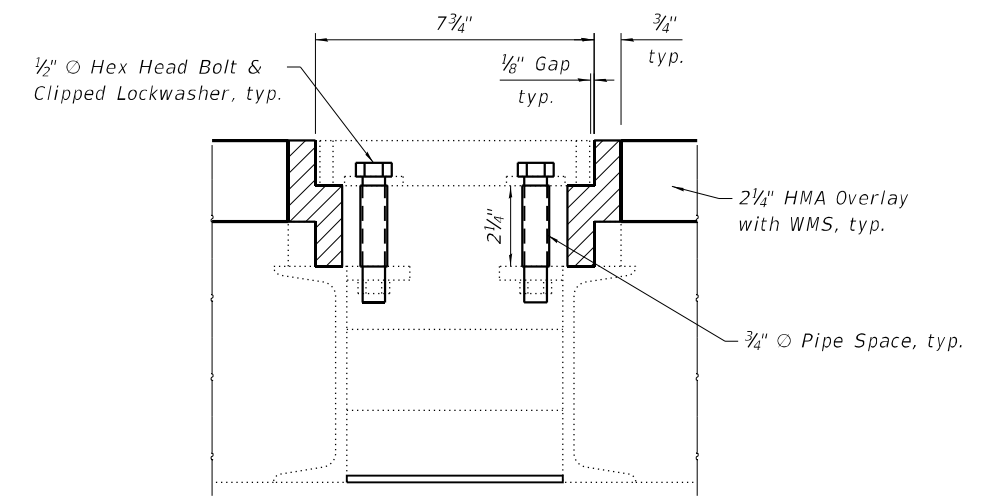
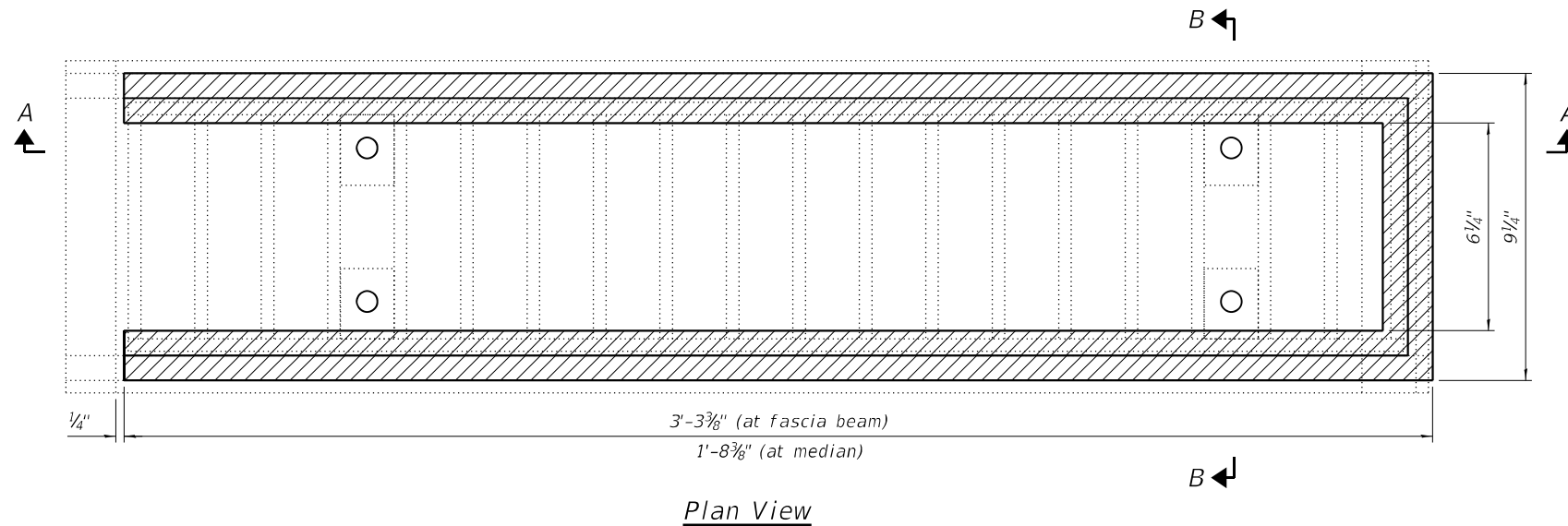

Notes:
 All structural steel shall be AASHTO M270 grade 36. The adjusting scupper ring and 3/4" ϕ pipe sleeve spacers shall be galvanized.
 Bolts shall be 1/2" ϕ AASHTO M164 type 1, mechanically galvanized.
 Plan dimensions and details relative to existing plans are subject to normal construction variations. The contractor shall field verify existing dimensions and details affecting new construction and make necessary approved adjustments prior to construction or ordering of materials. Such variations shall not be cause for additional compensation for a change in scope of the work, however, the contractor will be paid for the quantity actually furnished based at the unit price bid for the work.
 Shop plans for proposed adjusting scupper ring shall be submitted for approval prior to fabrication.
 Adjusting scupper rings are included in the cost per unit each of "Drainage scuppers to be adjusted".
 Extension steel shall be grade 36.

 Adjusting Scupper Ring

BILL OF MATERIAL

ITEM	UNIT	QUANTITY
Drainage Scuppers To Be Adjusted	Each	26

MODEL: Default
 FILE NAME: Z:\15052.29_B&O_RR_Bridge\DCN\Bridg\final\Plotsheets\0820017-76K02-029-Drainage_Details.dgn

8/13/2024 9:41:40 AM

EFK•Moen
 Civil Engineering Design

USER NAME = khill
 PLOT SCALE = 0.1667"/in.
 PLOT DATE = 8/13/2024

DESIGNED - ACB
 CHECKED - CDL
 DRAWN - ACB
 CHECKED - CDL

REVISED -
 REVISED -
 REVISED -
 REVISED -

STATE OF ILLINOIS
 DEPARTMENT OF TRANSPORTATION

DRAINAGE SCUPPER ADJUSTMENT DETAILS
 STRUCTURE NO. 082-0017

SHEET 29 OF 114 SHEETS

F.A.I. RTE.	SECTION	COUNTY	TOTAL SHEETS	SHEET NO.
55/70	82-5VB-R-2	ST. CLAIR	254	167

CONTRACT NO. 76K02
 ILLINOIS FED. AID PROJECT

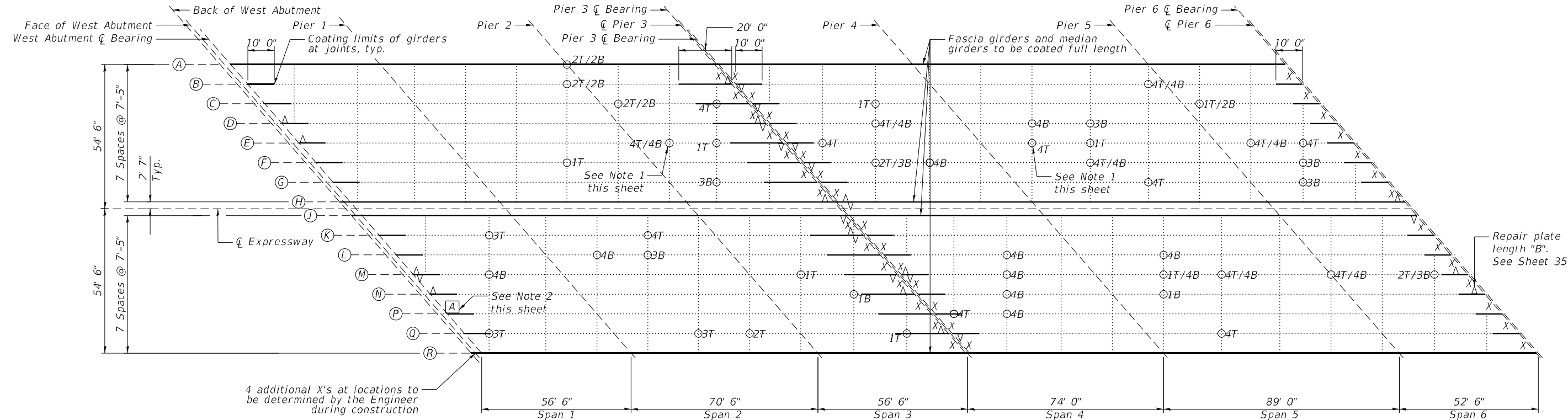
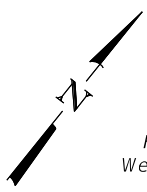

Notes:

1. While replacing bolts, install an appropriately sized fill plate between connection angle and girder web. Locations shown likely to require fill plates up to 1/2". Contractor to verify if additional fill plates needed at diaphragm connection angles. Cost included with Bolt Replacement.
2. Anchor bolt nut to be replaced and tightened at West Abutment, Girder P. See note on Sheet 33.

PARTIAL FRAMING PLAN

LEGEND		Count (This Sheet)	Notes (See Sheet 33)	Detail (See Sheet 33 U.N.O.)
○#T/#B	Location of rivet or bolt failures, number of rivets or bolts to be replaced, and where failure is located (in spans with diaphragm beams: top, T, or bottom, B, connection angle; in spans with cross frames: top or bottom region of vertical connection angle, or top or bottom connection plate)	188	2,3,4	
X	Location where diaphragm is to be replaced	46	1	Detail 1
▲	Location where cracked cross frame connection angles are to be replaced		5,6	Detail 2
△	Location where section loss of bearing stiffeners to be retrofit	29		Sheet 35
A	Location where anchor bolt nut to be replaced and tightened	1	8	
C1	Locations where cross frame top connection plates are to be replaced			Detail 2
C2	Locations where cross frame bottom connection plates are to be replaced			Detail 2
C3	Locations where cross frame bottom chord and diagonal angle are to be replaced			Detail 2
D1	Locations where cross frame top chord is to be replaced			Detail 2
G	Location where girder section loss to be supplemented with cover plate			Sheet 36
S	Location where seismic retainer angle to be replaced			Sheet 36

MODEL: Default
FILE NAME: \\jwc.com\p\NB\2014\2014.6xxx\2014.6410.5 - W029 B&O Bridge PS&E and TMP (SMG)\09 Drawings\0820017-76K02-030_Framing Plan and Repair Locations.dgn
8/13/2024 12:55:00 PM

WJE ENGINEERS ARCHITECTS MATERIAL SCIENTISTS
Wass, Janney, Elstner Associates, Inc.
330 Pfingsten Road
Northbrook, Illinois 60062
847.272.7400 tel | 847.291.9595 fax

USER NAME = MGolde	DESIGNED - PJM	REVISED -
PLOT SCALE = 0.1667"/in.	CHECKED - AW	REVISED -
PLOT DATE = 8/13/2024	DRAWN - LS	REVISED -
	CHECKED - PJM/SMG	REVISED -

**STATE OF ILLINOIS
DEPARTMENT OF TRANSPORTATION**

**FRAMING PLAN AND REPAIR LOCATIONS (1 OF 3)
STRUCTURE NO. 082-0017**

SHEET 30 OF 114 SHEETS

F.A.I. RTE.	SECTION	COUNTY	TOTAL SHEETS	SHEET NO.
55/70	82-5VB-R-2	ST. CLAIR	254	168
CONTRACT NO. 76K02				
ILLINOIS FED. AID PROJECT				

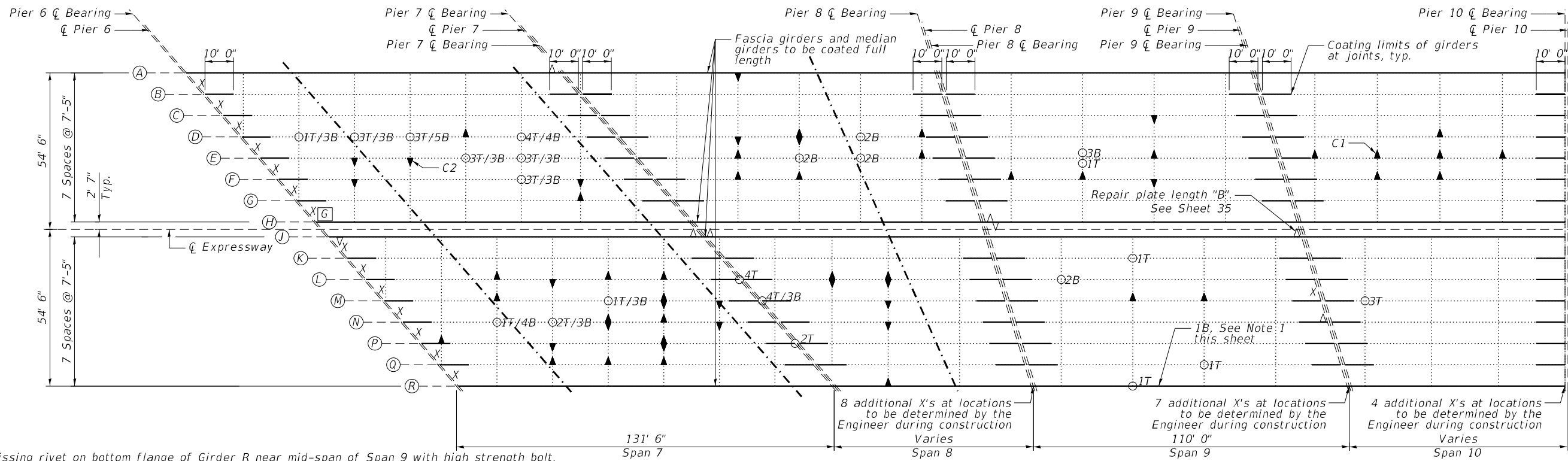
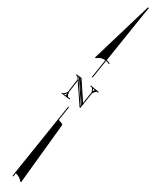

Notes:

1. Replace (1) missing rivet on bottom flange of Girder R near mid-span of Span 9 with high strength bolt. See note on Sheet 33.
2. Girder temporary bracing may be required where cross-frame connection angles are being replaced. The Contractor shall provide a work plan with details of the temporary bracing design or calculations showing that temporary bracing is not required. The work plan shall be prepared and sealed by a Structural Engineer licensed in the State of Illinois.

PARTIAL FRAMING PLAN

LEGEND		Count (This Sheet)	Notes (See Sheet 33)	Detail (See Sheet 33 U.N.O.)
O#T/#B	Location of rivet or bolt failures, number of rivets or bolts to be replaced, and where failure is located (in spans with diaphragm beams: top, T, or bottom, B, connection angle; in spans with cross frames: top or bottom region of vertical connection angle, or top or bottom connection plate)	90	2,3,4	
X	Location where diaphragm is to be replaced	34	1	Detail 1
▲	Location where cracked cross frame connection angles are to be replaced	55	5,6	Detail 2
Δ	Location where section loss of bearing stiffeners to be retrofit	7		Sheet 35
A	Location where anchor bolt nut to be replaced and tightened		8	
C1	Locations where cross frame top connection plates are to be replaced	1		Detail 2
C2	Locations where cross frame bottom connection plates are to be replaced	1		Detail 2
C3	Locations where cross frame bottom chord and diagonal angle are to be replaced			Detail 2
D1	Locations where cross frame top chord is to be replaced			Detail 2
G	Location where girder section loss to be supplemented with cover plate	1		Sheet 36
S	Location where seismic retainer angle to be replaced			Sheet 36

MODEL: Default
 FILE NAME: \\jwc.com\p\NB\2014\2014.6xxx\2014.6410.5 - W029 B&O Bridge PS&E and TMP (SMG)\09 Drawings\0820017-76K02-031 Framing Plan and Repair Locations.dgn
 8/13/2024 12:55:01 PM

WJE ENGINEERS ARCHITECTS MATERIAL SCIENTISTS
 Wess, Janney, Elstner Associates, Inc.
 330 Pfingsten Road
 Northbrook, Illinois 60062
 847.272.7400 tel | 847.291.9595 fax

USER NAME = MGolde	DESIGNED - PJM	REVISED -
PLOT SCALE = 0.1667"/in.	CHECKED - AW	REVISED -
PLOT DATE = 8/13/2024	DRAWN - LS	REVISED -
	CHECKED - PJM/SMG	REVISED -

STATE OF ILLINOIS
DEPARTMENT OF TRANSPORTATION

FRAMING PLAN AND REPAIR LOCATIONS (2 OF 3)
STRUCTURE NO. 082-0017

SHEET 31 OF 114 SHEETS

F.A.I. RTE.	SECTION	COUNTY	TOTAL SHEETS	SHEET NO.
55/70	82-5VB-R-2	ST. CLAIR	254	169
CONTRACT NO. 76K02				
ILLINOIS FED. AID PROJECT				

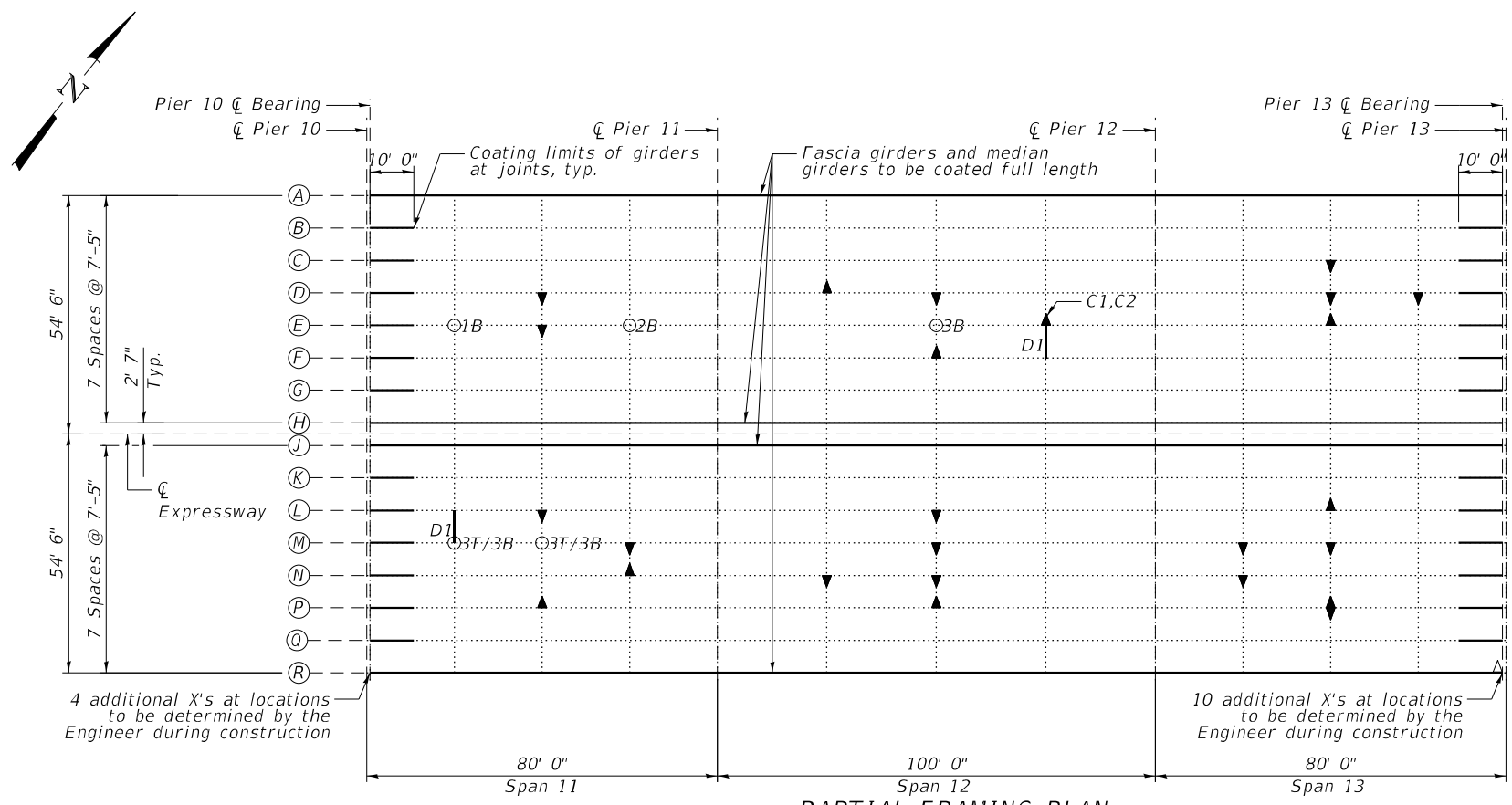

PARTIAL FRAMING PLAN

Notes:

1. Seismic retainer angle on south face of Girder H to be repaired per detail on Sheet 36.
2. Girder temporary bracing may be required where cross-frame connection angles are being replaced. The Contractor shall provide a work plan with details of the temporary bracing design or calculations showing that temporary bracing is not required. The work plan shall be prepared and sealed by a Structural Engineer licensed in the State of Illinois.

LEGEND		Count (This Sheet)	Notes (See Sheet 33)	Detail (See See Sheet 33 U.N.O.)
○#T/#B	Location of rivet or bolt failures, number of rivets or bolts to be replaced, and where failure is located (in spans with diaphragm beams: top, T, or bottom, B, connection angle; in spans with cross frames: top or bottom region of vertical connection angle, or top or bottom connection plate)	28	2,3,4	
X	Location where diaphragm is to be replaced	56	1	Detail 1
▲	Location where cracked cross frame connection angles are to be replaced	89	5,6	Detail 2
△	Location where section loss of bearing stiffeners to be retrofit	2		Sheet 35
[A]	Location where anchor bolt nut to be replaced and tightened		8	
C1	Locations where cross frame top connection plates are to be replaced	5		Detail 2
C2	Locations where cross frame bottom connection plates are to be replaced	2		Detail 2
C3	Locations where cross frame bottom chord and diagonal angle are to be replaced	1		Detail 2
D1	Locations where cross frame top chord is to be replaced	6		Detail 2
[G]	Location where girder section loss to be supplemented with cover plate	1		Sheet 36
[S]	Location where seismic retainer angle to be replaced	1		Sheet 36

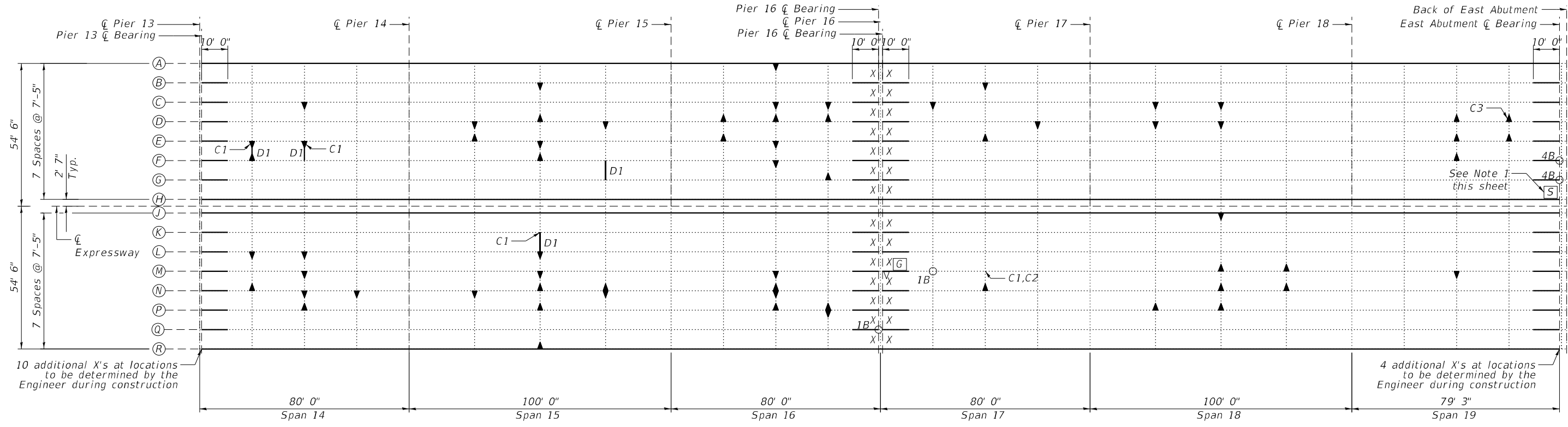

PARTIAL FRAMING PLAN

MODEL: Default
 FILE NAME: \\wje.com\p\NB\2014\2014.6xxx\2014.6410.5 - W029 B&O Bridge PS&E and TMP (SMG)\09 Drawings\082001.7-76K02-032 Framing Plan and Repair Locations.dgn
 8/13/2024 12:55:02 PM

WJE ENGINEERS ARCHITECTS MATERIAL SCIENTISTS
 Wss, Janney, Elstner Associates, Inc.
 330 Plingsten Road
 Northbrook, Illinois 60062
 847.272.7400 tel | 847.291.9595 fax

USER NAME = MGolde	DESIGNED - PJM	REVISED -
PLOT SCALE = 0.1667"/in.	CHECKED - AW	REVISED -
PLOT DATE = 8/13/2024	DRAWN - LS	REVISED -
	CHECKED - PJM/SMG	REVISED -

STATE OF ILLINOIS
DEPARTMENT OF TRANSPORTATION

FRAMING PLAN AND REPAIR LOCATIONS (3 OF 3)
STRUCTURE NO. 082-0017

SHEET 32 OF 114 SHEETS

F.A.I. RTE.	SECTION	COUNTY	TOTAL SHEETS	SHEET NO.
55/70	82-5VB-R-2	ST. CLAIR	254	170
CONTRACT NO. 76K02				
ILLINOIS FED. AID PROJECT				

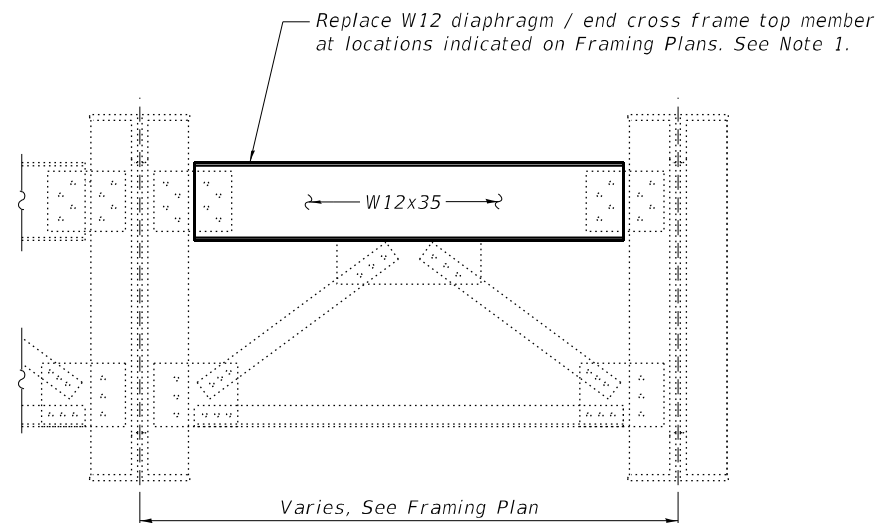

DETAIL 1 END CROSS FRAME DETAIL

Note:
End cross frame in Spans 7-19 shown. End diaphragms in Spans 1-6 similar, and shall consist of W12x35 replacement members

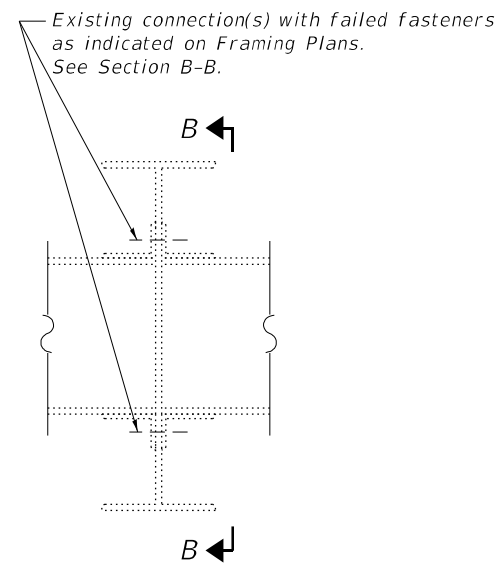

DETAIL 3 INTERMEDIATE DIAPHRAGM BEAM SPAN

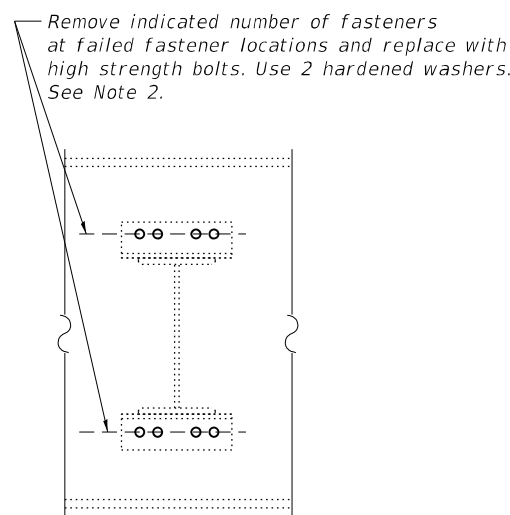

SECTION B-B

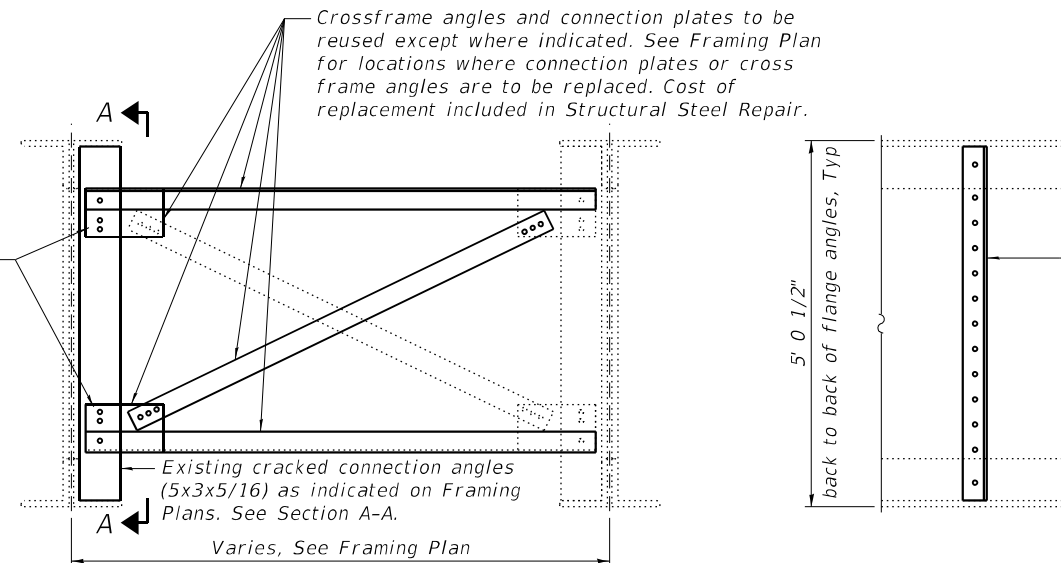

DETAIL 2 INTERMEDIATE CROSS FRAME DETAIL

SECTION A-A

Remove and replace crossframe connection angles and install new angle and crossframe elements using high strength bolts and two Hardened washers. New angles shall be L5x3x3/8. See Notes 5 and 6. Cost included in Structural Steel Repair.

Notes:

1. Specific end diaphragms or end cross frame top chord members, as indicated by "X's" in the framing plans, are to be replaced based on cracked connections, widespread corrosion, or similar damage. Additional diaphragms / end cross frame top chord member for each pier, as shown on the framing plans, shall be fabricated as part of the work. During construction, the Engineer will designate which of the approximately 28 members per pier are to be replaced based on the number of fabricated members for a given pier or abutment. Holes connecting the new diaphragm or end cross frame top chord shall be match drilled. Cost included in "Structural Steel Repair".
2. At some locations for both top and bottom bolt replacement in Span 1-6 intermediate diaphragms, holes may be misaligned. Temporary manipulation of the diaphragm may be required to re-align the holes. Cost included in "Bolt Replacement".
3. Existing bolts or rivets, in cross frames, where indicated for Spans 7-19 are to be replaced with 7/8" Ø bolts. Ream holes in existing cross frame connection plates to 15/16" Ø as required for 7/8" Ø bolts. Existing fasteners are typically 3/4" diameter.
4. Where bolts or rivets are indicated to be replaced, inspect the bolts or rivets on both the connection angle and the top or bottom connection plate on both sides of girder to identify the indicated number of loose or broken bolts to be replaced.
5. Holes between replacement angles and connection plates should be match-drilled in the field to ensure fit-up. Where new angles are installed, ream holes in existing cross frame connection plates to 15/16" Ø as required for 7/8" Ø bolts. Existing fasteners for connection plates are typically 3/4" diameter. Notify the engineer if existing connection plates to be reused cannot accommodate new bolt placement. Cost included in "Structural Steel Repair".
6. At locations where cross frame angles are to be removed and replaced, Contractor shall demonstrate adequate bracing of the girders through all stages of construction. See Specifications and GBSP67.
7. Based on the existing conditions identified during the 2020 and 2021 inspections, a total of 55,850 pounds of structural steel repair is anticipated - 48,150 pounds of diaphragm replacement, 7,700 pounds of cross frame repairs.
8. Based on the existing conditions identified during the 2020 and 2021 inspections, a total of 307 bolt replacements are anticipated. In addition to diaphragm and cross frame locations where bolts are identified to be replaced in the framing plans, this includes two additional bolt replacements. One at the West Abutment, Girder P, where the anchor bolt nut is to be replaced and one in Span 9, Girder R at the bottom flange cover plate. Refer to Framing Plans for locations.
9. Cleaning and Painting of contact surfaces in Spans 1-10 shall meet the requirements of Primary Connections as specified in the special provision "Cleaning and Painting Contact Surface Areas of Steel Structures" Cleaning and Painting of contact surfaces in Spans 11-19 shall meet the requirements of Secondary Connections as specified in the special provision "Cleaning and Painting Contact Surface Areas of Steel Structures."

BILL OF MATERIAL

Item	Unit	Total
Structural Steel Repair	Pound	55,850
Bolt Replacement	Each	307

MODEL: Default
FILE NAME: \\wje.com\p\NB\2014\2014.6xxx\2014.6xxx\2014.6xxx\0820017-76K02-033_Diaphragm and Cross Frame Repair.dgn

WJE ENGINEERS ARCHITECTS MATERIAL SCIENTISTS
Wiss, Janney, Elstner Associates, Inc.
330 Pfingsten Road
Northbrook, Illinois 60062
847.272.7400 tel | 847.291.9595 fax
www.wje.com

USER NAME = MGolde
DESIGNED - PJM
CHECKED - AW
PLOT SCALE = 0.1667"/in.
DRAWN - LS
PLOT DATE = 8/13/2024
CHECKED - PJM/SMG
REVISED -

DESIGNED - PJM
CHECKED - AW
DRAWN - LS
PLOT DATE = 8/13/2024
CHECKED - PJM/SMG
REVISED -

DESIGNED - PJM
CHECKED - AW
DRAWN - LS
PLOT DATE = 8/13/2024
CHECKED - PJM/SMG
REVISED -

**STATE OF ILLINOIS
DEPARTMENT OF TRANSPORTATION**

**DIAPHRAGM AND CROSS FRAME REPAIR
STRUCTURE NO. 082-0017**

SHEET 33 OF 114 SHEETS

F.A.I. RTE.	SECTION	COUNTY	TOTAL SHEETS	SHEET NO.
55-70	82-5VB-R-2	ST. CLAIR	254	171
CONTRACT NO. 76K02				
ILLINOIS FED. AID PROJECT				

MODEL: Default
 FILE NAME: \\wje.com\p\NB\2014\2014.6xxx\2014.6410.5 - W029 B&O Bridge PS&E and TMP (SMG)\09 Drawings\082001.7\76K02-035_Bearing Stiffener Repairs.dgn
 8/13/2024 12:55:05 PM

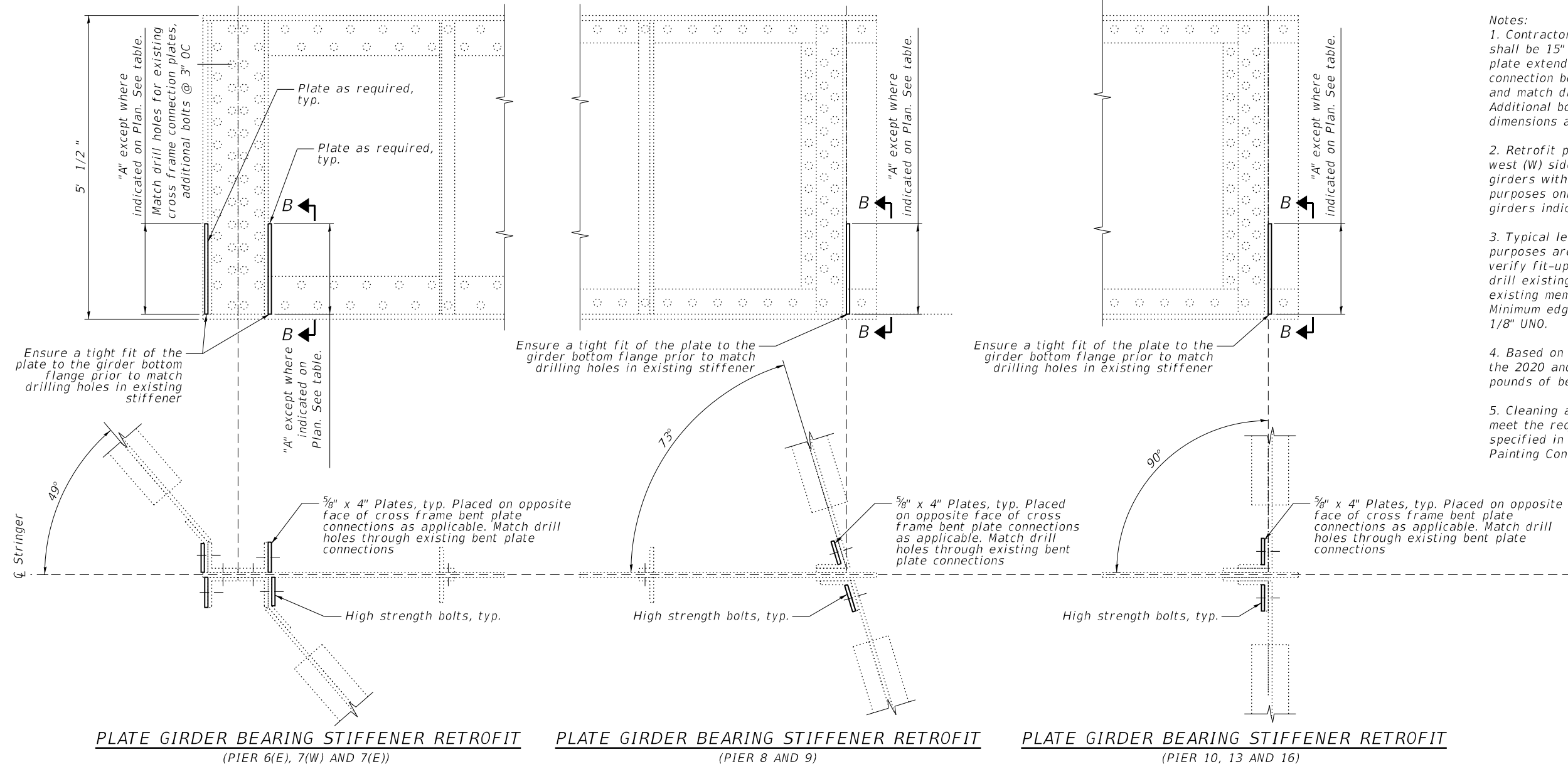
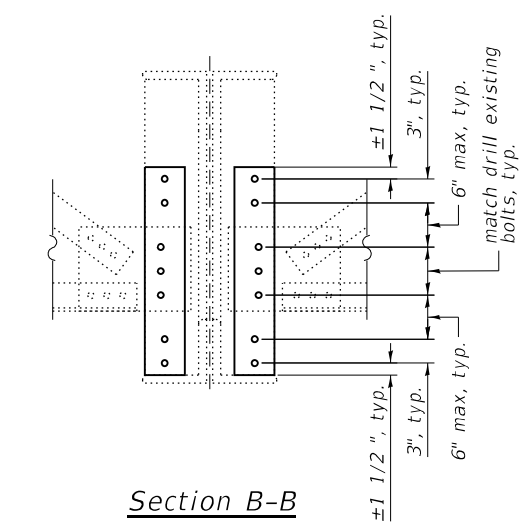

PLATE GIRDER BEARING STIFFENER RETROFIT
 (PIER 6(E), 7(W) AND 7(E))

PLATE GIRDER BEARING STIFFENER RETROFIT
 (PIER 8 AND 9)

PLATE GIRDER BEARING STIFFENER RETROFIT
 (PIER 10, 13 AND 16)

- Notes:**
- Contractor to VIF plate dimensions. Repair plates shall be 15" tall, minimum. Where the top of a 15" plate extends above existing end diaphragm connection bolts, extend plate to top of diaphragm and match drill diaphragm connection bolts. Additional bolts @3" as shown. Use typical "A" dimensions at all locations.
 - Retrofit plates shown on both the east (E) and west (W) side of the girder or at both stiffeners for girders with 2 bearing stiffeners for illustrative purposes only. Only required at the side of the girders indicated on the plan sheets.
 - Typical lengths of repair plates for bidding purposes are shown in table. Contractor shall field verify fit-up prior to fabrication and shall match drill existing holes in new plates or match drill existing members for new holes in repair plates. Minimum edge clearance for all 7/8" bolts shall be 1 1/8" UNO.
 - Based on the existing conditions identified during the 2020 and 2021 inspections, a total of 620 pounds of bearing stiffener repairs is anticipated.
 - Cleaning and Painting of contact surfaces shall meet the requirements for Primary Connections as specified in the special provision "Cleaning and Painting Contact Surface Areas of Steel Structures."



Section B-B

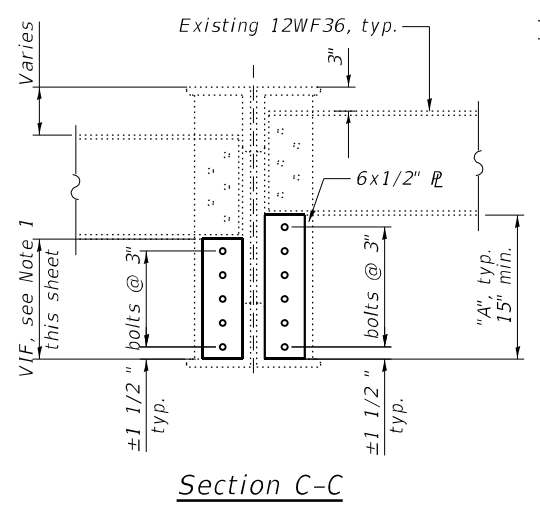

Section C-C

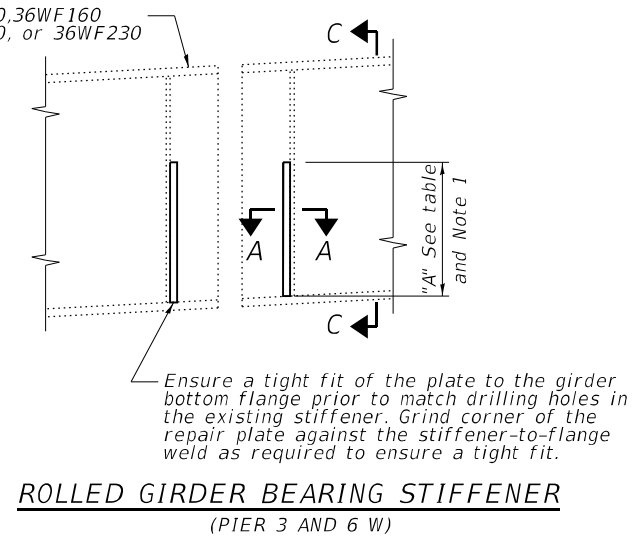

ROLLED GIRDER BEARING STIFFENER
 (PIER 3 AND 6 W)

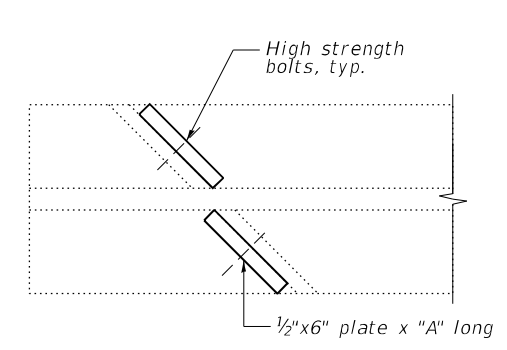

SECTION A-A

RETROFIT DIMENSIONS

Pier	"A"	"B"
3	18"	
6 (W)	18"	33 1/2"
6 (E)	18"	
7	18"	
8	18"	
9 (W)	18"	58 3/4"
9 (E)	18"	
10	18"	
13	18"	
16	18"	

BILL OF MATERIAL

ITEM	UNIT	QUANTITY
Structural Steel Repair	Pound	620

WJE ENGINEERS ARCHITECTS MATERIAL SCIENTISTS
 Wss, Janney, Elstner Associates, Inc.
 330 Pfingsten Road
 Northbrook, Illinois 60062
 847.272.7400 tel | 847.291.9595 fax

USER NAME = MGold	DESIGNED - PJM	REVISED -
PLOT SCALE = 0.1667' / in.	CHECKED - AW	REVISED -
PLOT DATE = 8/13/2024	DRAWN - LS	REVISED -
	CHECKED - PJM/SMG	REVISED -

STATE OF ILLINOIS
DEPARTMENT OF TRANSPORTATION

BEARING STIFFENER REPAIRS
S.N. 082-0017

SHEET 35 OF 114 SHEETS

F.A.I. RTE.	SECTION	COUNTY	TOTAL SHEETS	SHEET NO.
55/70	82-5VB-R-2	ST. CLAIR	254	173
CONTRACT NO. 76K02				
ILLINOIS FED. AID PROJECT				

MODEL: Default
 FILE NAME: \\wje.com\p\NB\2014\2014.6xxx\2014.6410.5 - W029 B&O Bridge PS&E and TMP (SMG)\09 Drawings\0820017-76K02-036_Girder and Drainage System Repairs.dgn
 8/13/2024 12:55:06 PM

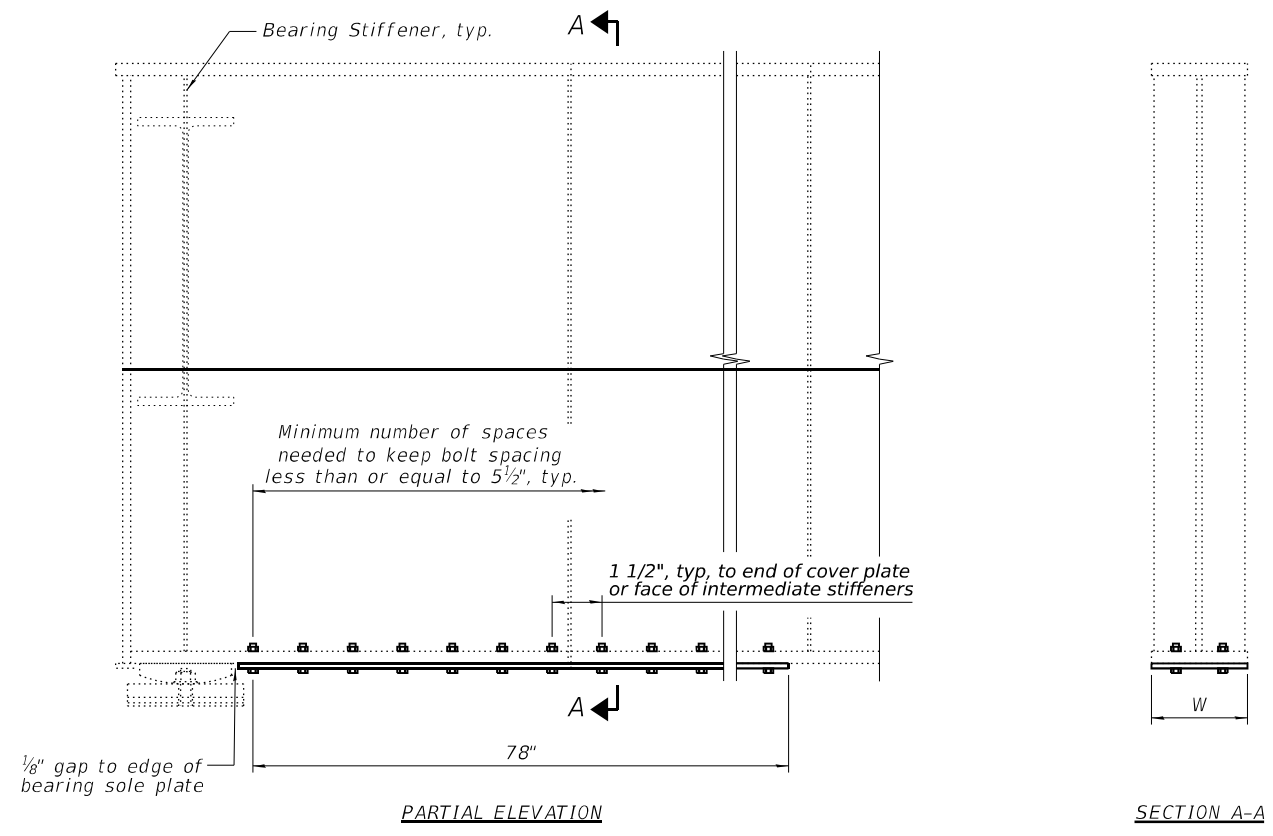

GIRDER FLANGE REPAIR DETAIL
 Girder bottom flange repairs:
 Pier 6 (E), Girder H: 1/2" x W = 15" x 78"
 Pier 16 (E), Girder M: 1/2" x W = 11" x 78"

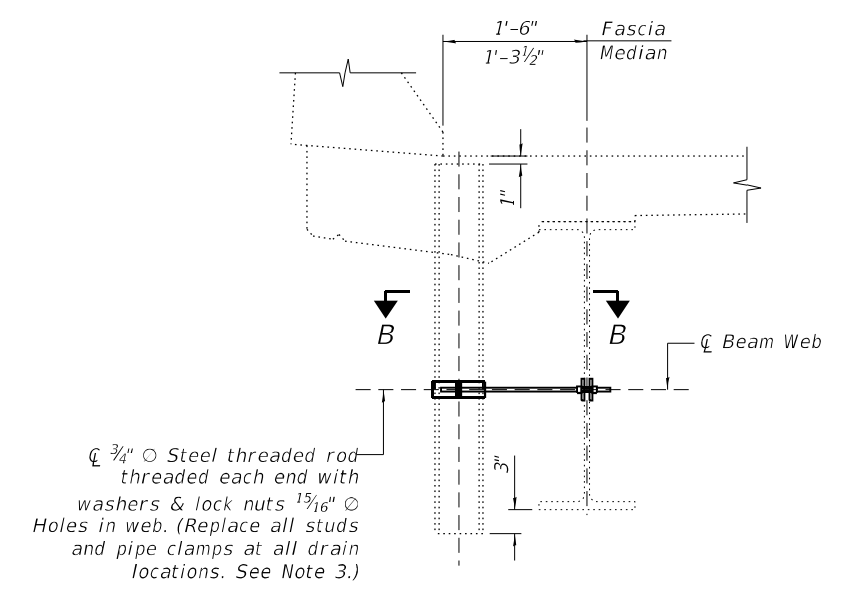

FLOOR DRAIN DETAILS
 Existing pipe to remain. Clean surface prior to attaching new clamp

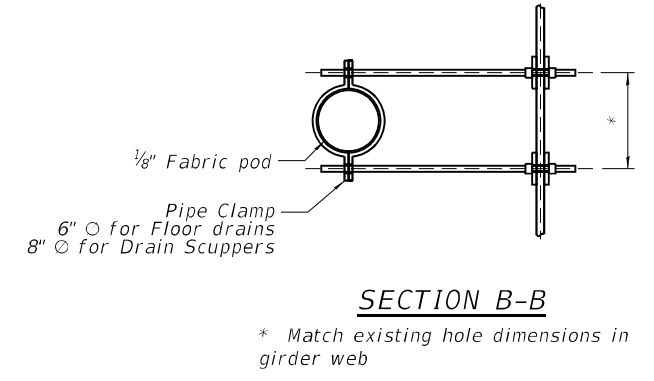
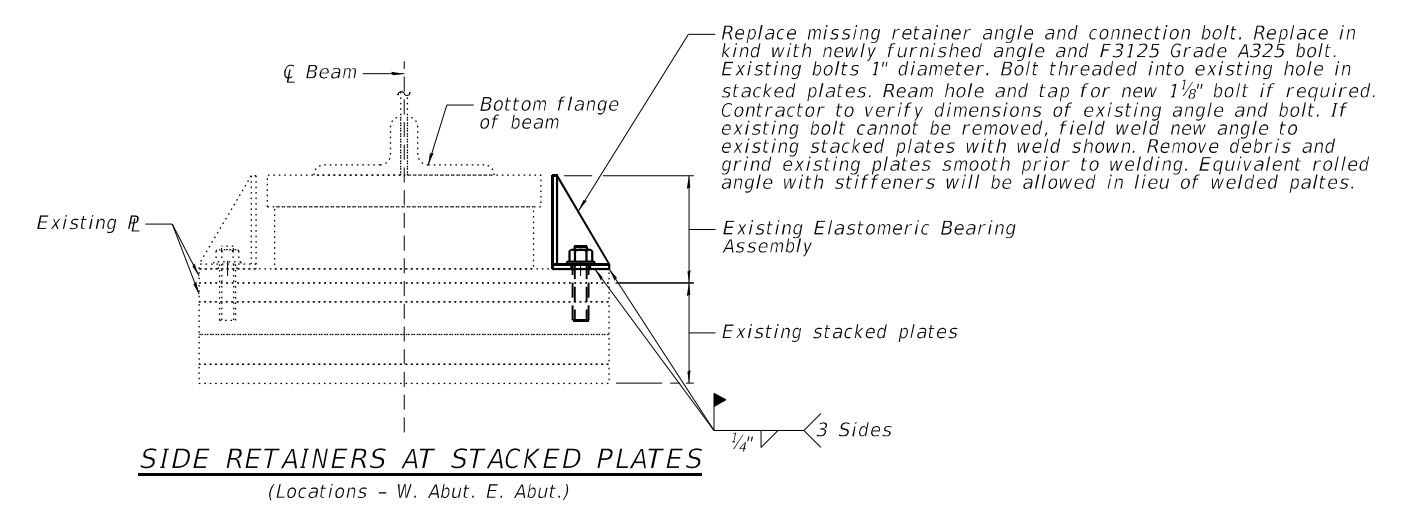

- Notes:
- All new hardware and threaded rods for floor drain attachment shall be hot dipped galvanized. Cost included with "Structural Steel Repair".
 - Based on the existing conditions identified during the 2020 and 2021 inspections, a total of 2,700 pounds of structural steel repair is anticipated - 300 pounds of girder flange repair, 20 pounds of side retainer repairs, and 2,380 pounds of floor drain hardware replacement.
 - At the approval of the Engineer, existing pipe clamps may be cleaned, painted and reused. All steel rods to be replaced with HDG rods.
 - Lengths of repair plates for bidding purposes are as shown. Contractor shall field verify fit-up prior to fabrication and shall match drill existing holes in new plates or match drill existing members for new holes in repair plates. Minimum edge clearance for all 7/8" bolts shall be 1 1/8" U.N.O.
 - Cleaning and Painting of contact surfaces shall meet the requirements for Primary Connections as specified in the special provision "Cleaning and Painting Contact Surface Areas of Steel Structures."

BILL OF MATERIAL

ITEM	UNIT	QUANTITY
Structural Steel Repair	Pound	2,700

WJE ENGINEERS ARCHITECTS MATERIAL SCIENTISTS
 Wss, Janney, Elstner Associates, Inc.
 330 Pfingsten Road
 Northbrook, Illinois 60062
 847.272.7400 tel | 847.291.9595 fax
 www.wje.com

USER NAME = MGolde	DESIGNED - PJM	REVISED -
PLOT SCALE = 0.1667"/in.	CHECKED - AW	REVISED -
PLOT DATE = 8/13/2024	DRAWN - LS	REVISED -
	CHECKED - PJM/SMG	REVISED -

STATE OF ILLINOIS
 DEPARTMENT OF TRANSPORTATION

GIRDER REPAIR AND DRAINAGE SYSTEM
 STRUCTURE NO. 082-0017

SHEET 36 OF 114 SHEETS

F.A.I. RTE.	SECTION	COUNTY	TOTAL SHEETS	SHEET NO.
55/70	82-5VB-R-2	ST. CLAIR	254	174
CONTRACT NO. 76K02				
ILLINOIS FED. AID PROJECT				

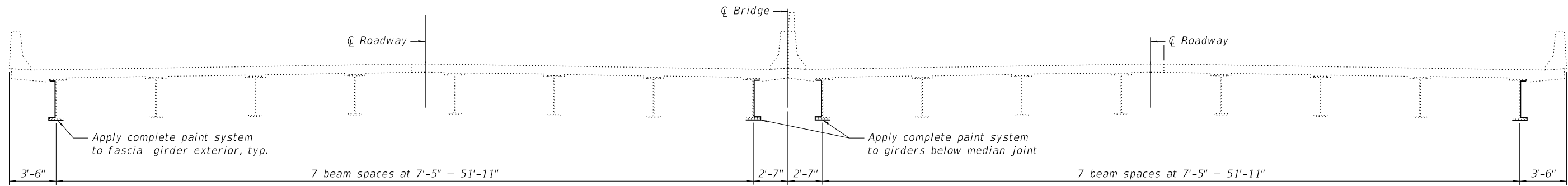

TYPICAL SECTION THROUGH SUPERSTRUCTURE AT MID-SPAN
(Looking East)

Paint Limits at Fascia and Median Girders:
Complete paint system shall be applied to the fascia girders to include all exterior girder surfaces, the underside of the top flange, and the bottom flange as shown.

Complete paint system shall also be applied to the median girders (H&J) to include all girder surfaces facing the centerline of the bridge, the underside of the top flanges, and bottom flanges as shown.

Conduit along exterior face of Fascia Girder A shall be supported during the work. Cost included with Conduit Support System.

Conduits along interior faces of Fascia Girders A and R were confirmed in November 2021 to be no longer active. These conduits are to be removed. Cost included with Cleaning and Painting Steel Bridge.

Paint Limits at Transverse Expansion Joints:
Complete paint system shall be applied to all structural steel within the limits shown on the framing plans.

Existing seismic restraint cable brackets to remain.

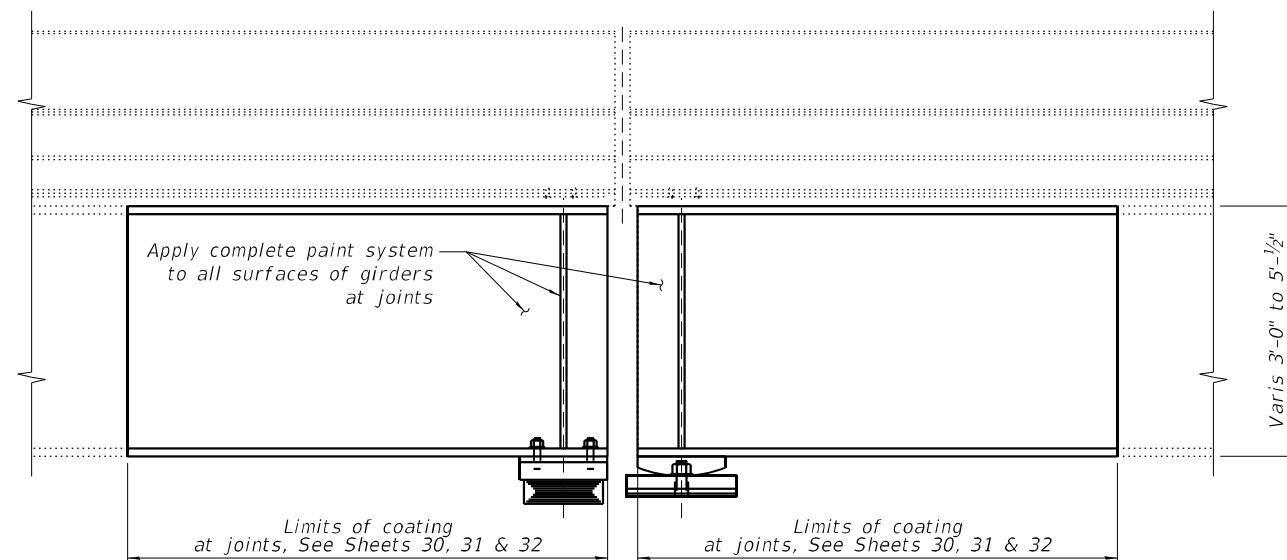

TYPICAL ELEVATION OF GIRDERS AT JOINTS

BILL OF MATERIAL

Item	Unit	Total
Cleaning and Painting Steel Bridge No. 1	Lump Sum	1
Containment and Disposal of Lead Paint Cleaning Residues No. 1	Lump Sum	1
Conduit Support System	Lump Sum	1

MODEL: Default
FILE NAME: \\wje.com\p\NB\2014\2014.6xxx\2014.6410.5 - W029 B&O Bridge PS&E and TMP (SMG)\09 Drawings\0820017-76K02-037_Limits of Steel Coating and Coating Details.dgn
8/13/2024 12:55:07 PM

WJE ENGINEERS ARCHITECTS MATERIAL SCIENTISTS
Wiss, Janney, Elstner Associates, Inc.
330 Pfingsten Road
Northbrook, Illinois 60062
847.272.7400 tel | 847.291.9595 fax
www.wje.com

USER NAME = MGolde	DESIGNED - PJM	REVISED -
	CHECKED - AW	REVISED -
PLOT SCALE = 0.1667"/in.	DRAWN - LS	REVISED -
PLOT DATE = 8/13/2024	CHECKED - PJM/SMG	REVISED -

**STATE OF ILLINOIS
DEPARTMENT OF TRANSPORTATION**

**LIMITS OF STEEL COATING AND COATING DETAILS
STRUCTURE NO. 082-0017**

SHEET 37 OF 114 SHEETS

F.A.I. RTE.	SECTION	COUNTY	TOTAL SHEETS	SHEET NO.
55/70	82-5VB-R-2	ST. CLAIR	254	175
CONTRACT NO. 76K02				
		ILLINOIS	FED. AID PROJECT	

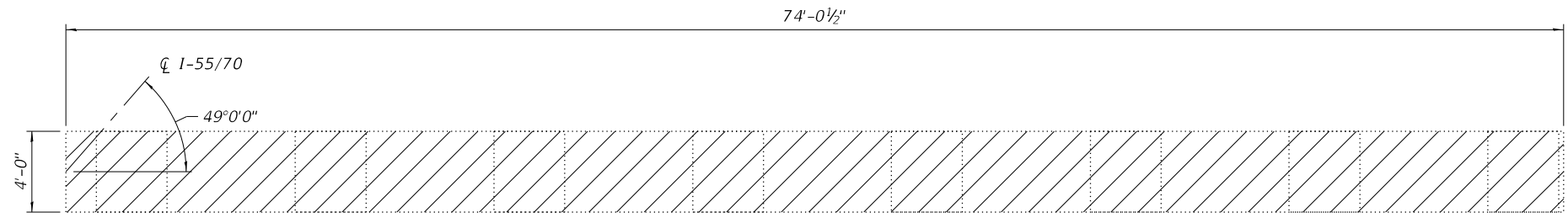

Plan

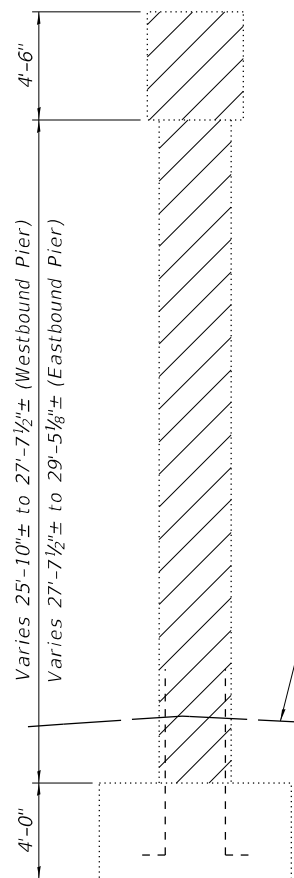
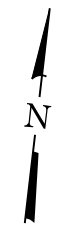

End View
(Looking East)

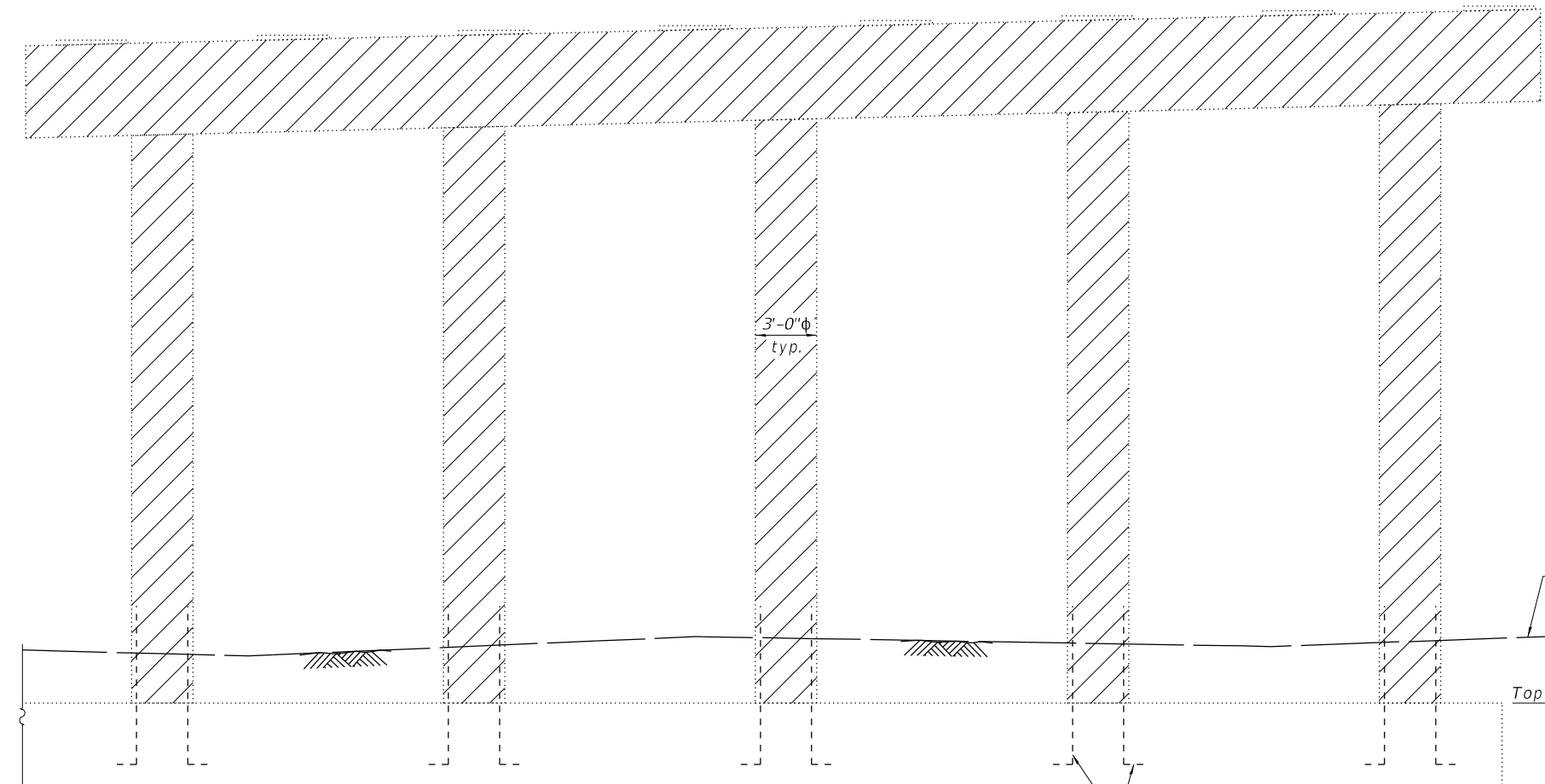

Elevation
(Looking North)
(Eastbound Structure Shown. Westbound Structure Similar)

Approximate Ground Line
Top of Soil (Average) Elev. 415.1
Top of Footing (Plan) Elev. 412.0

Existing reinforcement extending out of the footing shall be cleaned, straightened, and incorporated into the new construction, typ.

Concrete Removal (Special)

Notes:
Structure excavation, as required for concrete removal, shall be considered included in the contract unit price for "Concrete Removal (Special)".
Removal of existing seismic retrofit retainer angles, existing restraint cables, and existing bearings are included in Concrete Removal (Special).
Seismic restraint cable brackets attached to girders are to remain.

BILL OF MATERIAL

ITEM	UNIT	QUANTITY
Concrete Removal (Special)	Cu. Yd.	170.8

MODEL: Default
FILE NAME: Z:\1505229_B&O_RR_Bridge\DCN\Bridg\final\Plotsheets\0820017-76K02-038-Pier_3_Substructure Removal.dgn



USER NAME = khill	DESIGNED - ACB	REVISED -
PLOT SCALE = 02" / ft.	CHECKED - CDL	REVISED -
PLOT DATE = 8/13/2024	DRAWN - ACB	REVISED -
	CHECKED - CDL	REVISED -

**STATE OF ILLINOIS
DEPARTMENT OF TRANSPORTATION**

**SUBSTRUCTURE REMOVAL (PIER 3)
STRUCTURE NO. 082-0017**

SHEET 38 OF 114 SHEETS

F.A.I. RTE.	SECTION	COUNTY	TOTAL SHEETS	SHEET NO.
55/70	82-5VB-R-2	ST. CLAIR	254	176
CONTRACT NO. 76K02				
		ILLINOIS	FED. AID PROJECT	

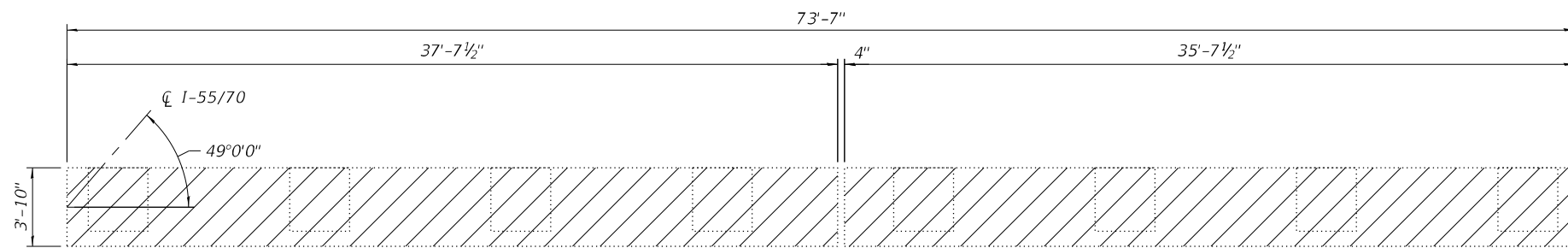

Plan

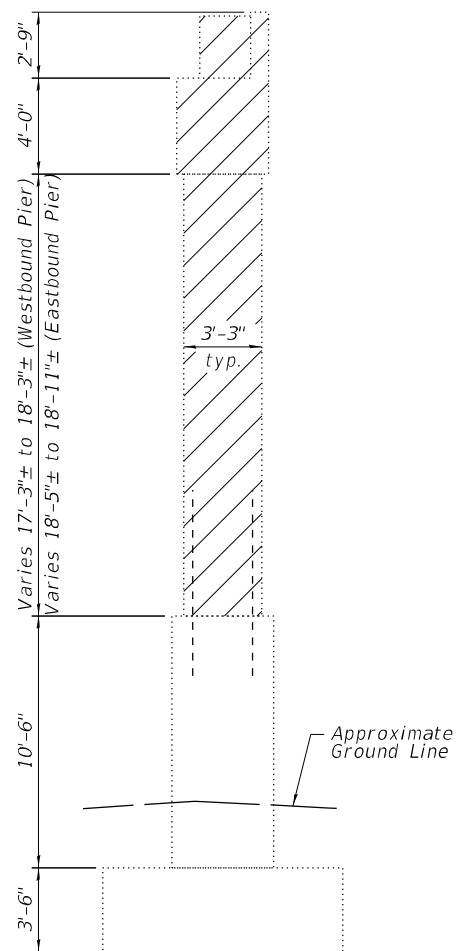

End View
(Looking East)

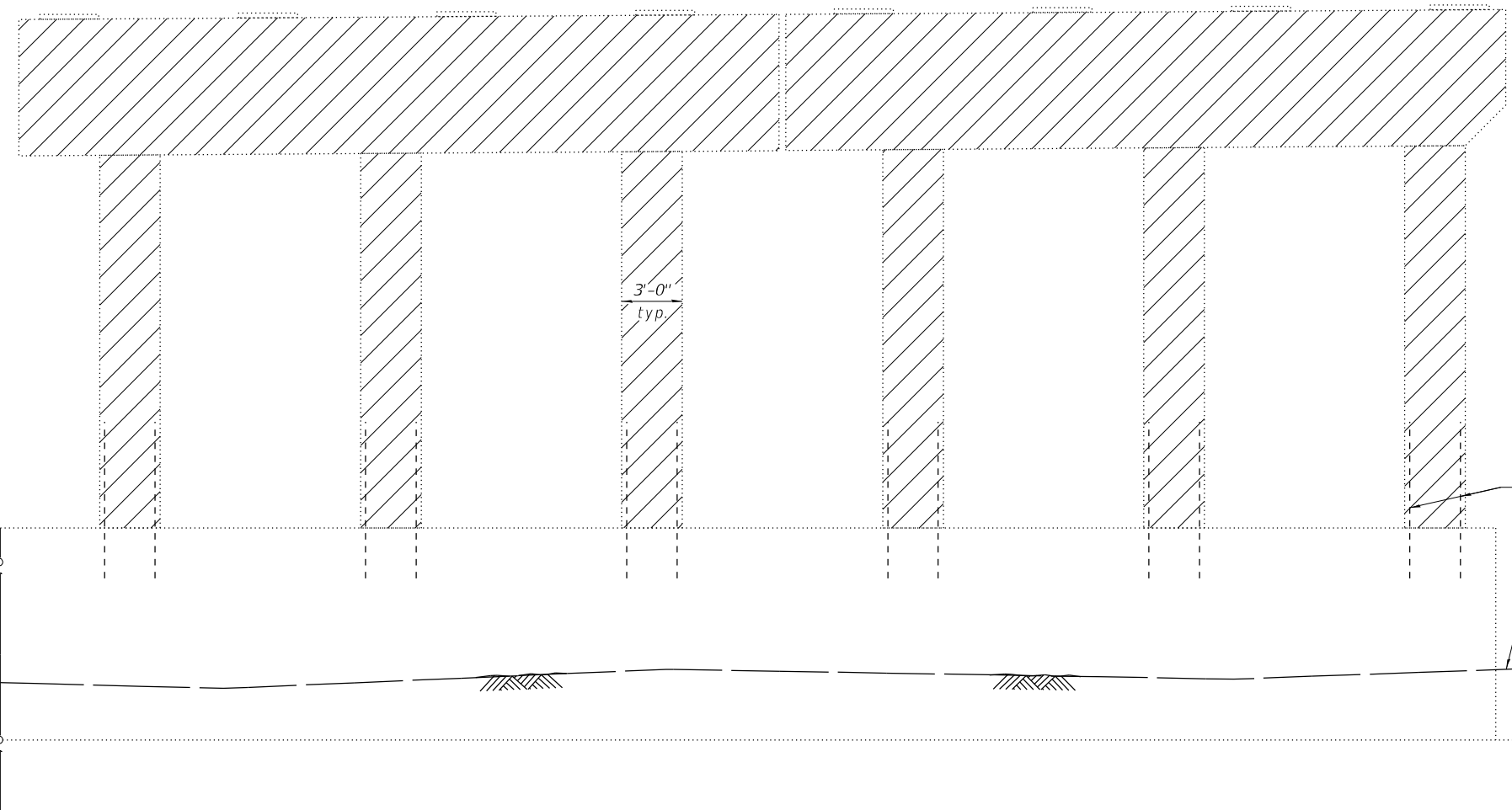

Elevation
(Looking North)
(Eastbound Structure Shown. Westbound Structure Similar)

Concrete Removal (Special)

Notes:
Removal of existing seismic retrofit retainer angles, existing restraint cables, and existing bearings are included in Concrete Removal (Special).
Seismic restraint cable brackets attached to girders are to remain.

BILL OF MATERIAL

ITEM	UNIT	QUANTITY
Concrete Removal (Special)	Cu. Yd.	186.3

MODEL: Default
FILE NAME: Z:\1505229_B&O_RR_Bridge\DCN\Bridg\final\Plotsheets\0820017-76K02-039-Pier_6_Substructure Removal.dgn

EFK•Moen
Civil Engineering Design

USER NAME = khill	DESIGNED - ACB	REVISED -
PLOT SCALE = 0.1667"/in.	CHECKED - CDL	REVISED -
PLOT DATE = 8/13/2024	DRAWN - ACB	REVISED -
	CHECKED - CDL	REVISED -

STATE OF ILLINOIS
DEPARTMENT OF TRANSPORTATION

SUBSTRUCTURE REMOVAL (PIER 6)
STRUCTURE NO. 082-0017

SHEET 39 OF 114 SHEETS

F.A.I. RTE.	SECTION	COUNTY	TOTAL SHEETS	SHEET NO.
55/70	82-5VB-R-2	ST. CLAIR	254	177
CONTRACT NO. 76K02				
ILLINOIS		FED. AID PROJECT		

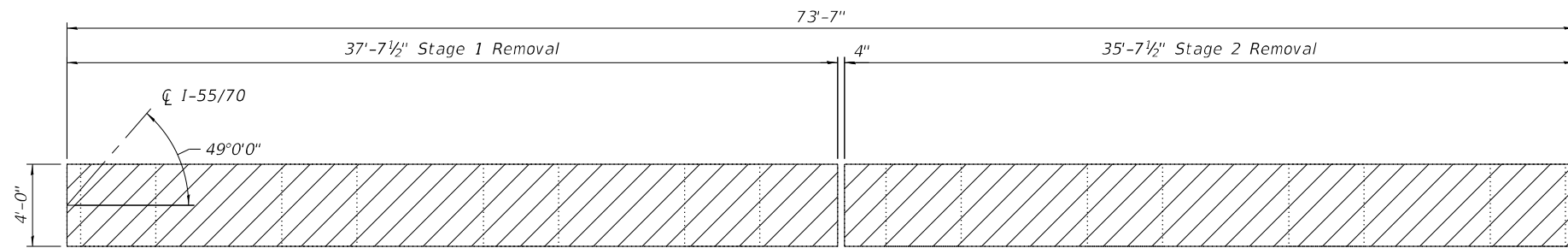

Plan
 (Stage removal shown for Eastbound replacement and strongback system per Sheets 97 thru 103 of 114. Refer to Sheet 85 of 114 for additional information.)

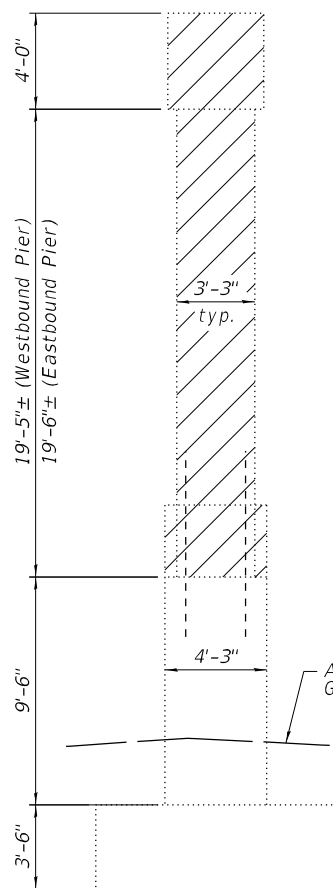
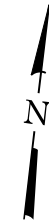

End View
 (Looking East)

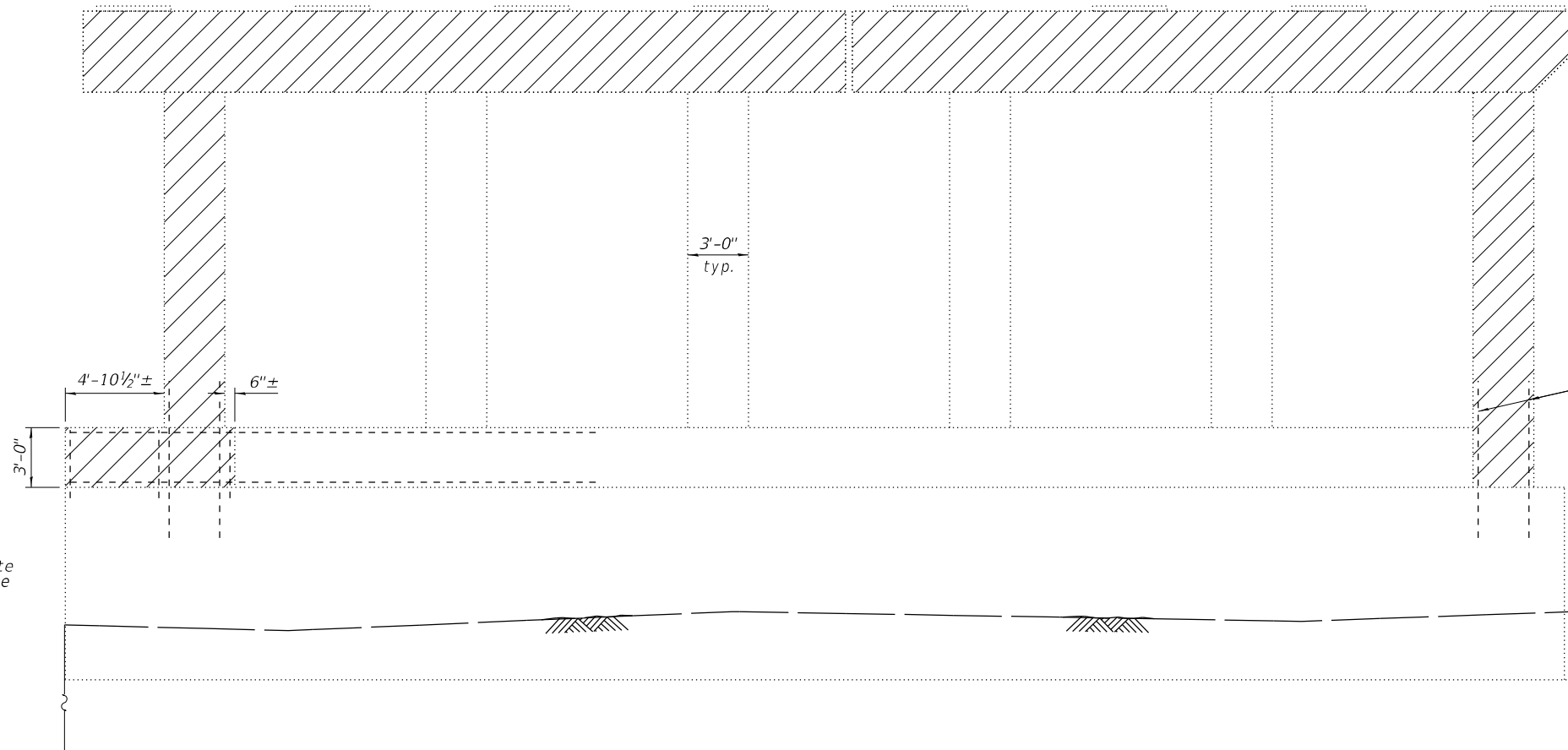

Elevation
 (Looking North)
 (Eastbound Structure Shown. Westbound Structure Similar)

Existing reinforcement extending out of the wall shall be cleaned, straightened, and incorporated into the new construction, typ.

Approximate Ground Line

Concrete Removal (Special)

Notes:
 Removal of existing seismic retrofit retainer angles, existing restraint cables, and existing bearings are included in Concrete Removal (Special).
 Seismic restraint cable brackets attached to girders are to remain.

BILL OF MATERIAL

ITEM	UNIT	QUANTITY
Concrete Removal (Special)	Cu. Yd.	118.8

MODEL: Default
 FILE NAME: Z:\1505229_B&O_RR_Bridge\DCN\Bridg\final\Plotsheets\0820017-76K02-040-Pier 7_Substructure Removal.dgn

EFK Moen
 Civil Engineering Design

USER NAME = khill	DESIGNED - ACB	REVISED -
PLOT SCALE = 0.1667"/in.	CHECKED - CDL	REVISED -
PLOT DATE = 8/13/2024	DRAWN - ACB	REVISED -
	CHECKED - CDL	REVISED -

STATE OF ILLINOIS
DEPARTMENT OF TRANSPORTATION

SUBSTRUCTURE REMOVAL (PIER 7)
STRUCTURE NO. 082-0017

SHEET 40 OF 114 SHEETS

F.A.I. RTE.	SECTION	COUNTY	TOTAL SHEETS	SHEET NO.
55/70	82-5VB-R-2	ST. CLAIR	254	178
CONTRACT NO. 76K02				
		ILLINOIS	FED. AID PROJECT	

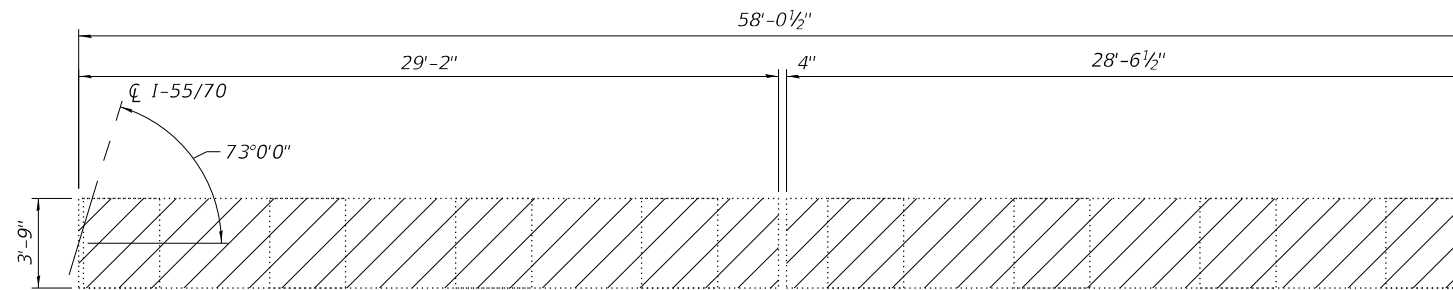

Plan

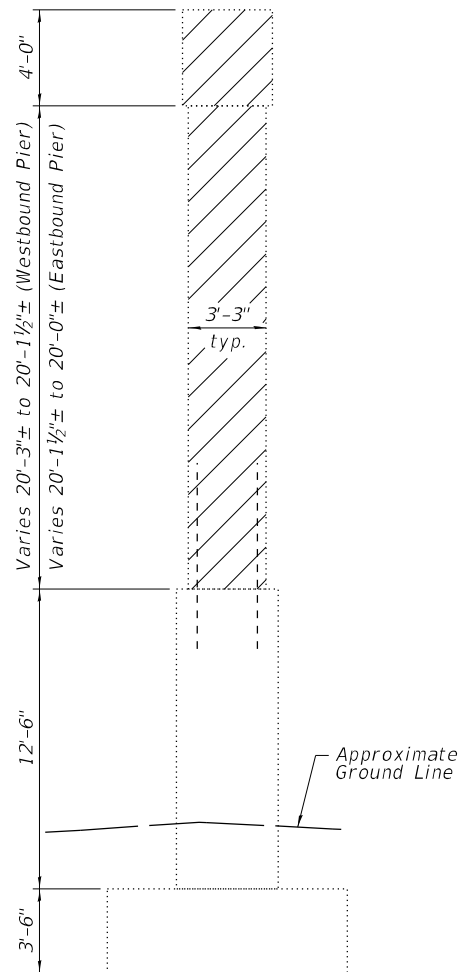
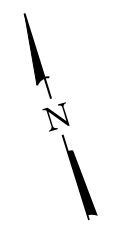

End View
(Looking East)

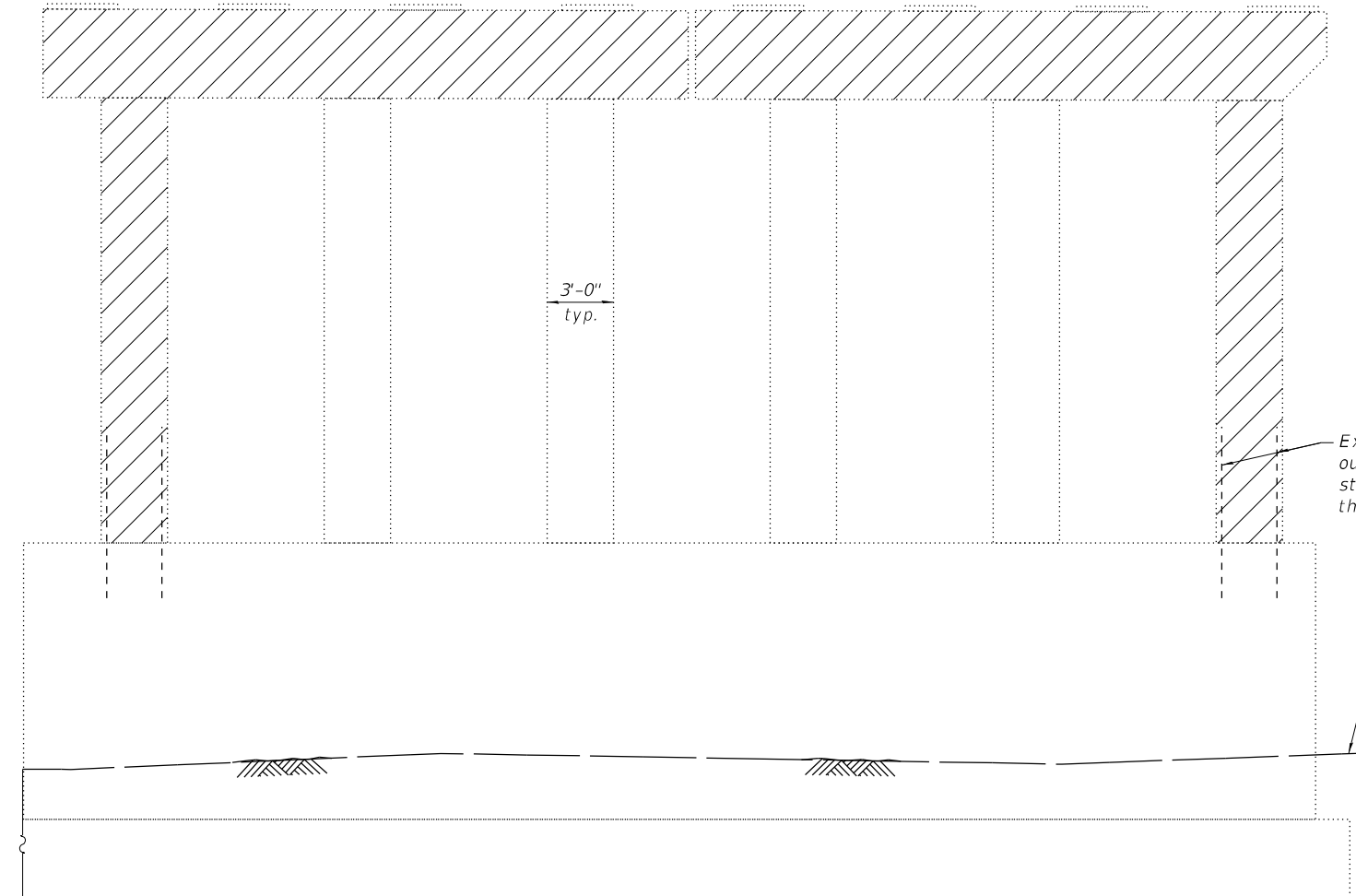

Elevation
(Looking North)
(Eastbound Structure Shown. Westbound Structure Similar)

Concrete Removal (Special)

Notes:
Removal of existing seismic retrofit retainer angles, existing restraint cables, and existing bearings are included in Concrete Removal (Special).
Seismic restraint cable brackets attached to girders are to remain.

BILL OF MATERIAL

ITEM	UNIT	QUANTITY
Concrete Removal (Special)	Cu. Yd.	92.4

MODEL: Default
FILE NAME: Z:\1505229_B&O_RR_Bridge\DCN\Bridges\final\Plotsheets\0820017-76K02-041-Pier_8_Substructure Removal.dgn
8/13/2024 9:41:43 AM



USER NAME = khill	DESIGNED - ACB	REVISED -
PLOT SCALE = 0.1667"/in.	CHECKED - CDL	REVISED -
PLOT DATE = 8/13/2024	DRAWN - ACB	REVISED -
	CHECKED - CDL	REVISED -

**STATE OF ILLINOIS
DEPARTMENT OF TRANSPORTATION**

**SUBSTRUCTURE REMOVAL (PIER 8)
STRUCTURE NO. 082-0017**

SHEET 41 OF 114 SHEETS

F.A.I. RTE.	SECTION	COUNTY	TOTAL SHEETS	SHEET NO.
55/70	82-5VB-R-2	ST. CLAIR	254	179
CONTRACT NO. 76K02				
ILLINOIS		FED. AID PROJECT		

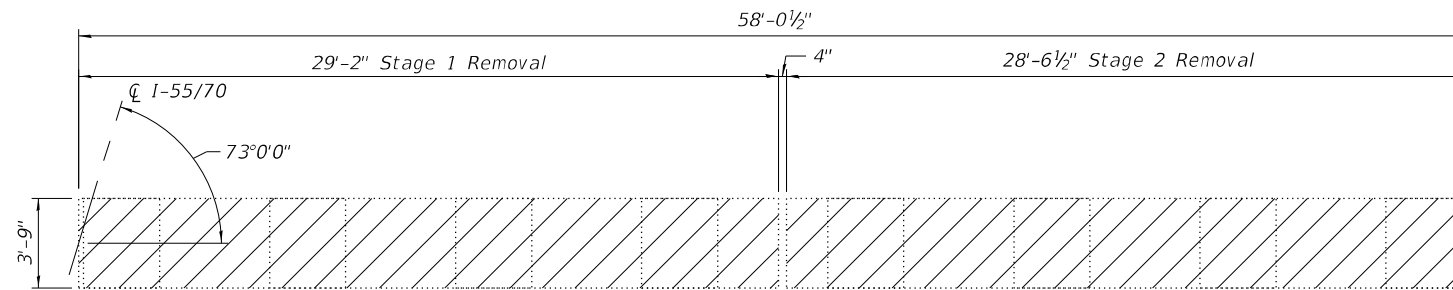

Plan

(Refer to Sheet 85 of 114 for additional information regarding staged construction.)

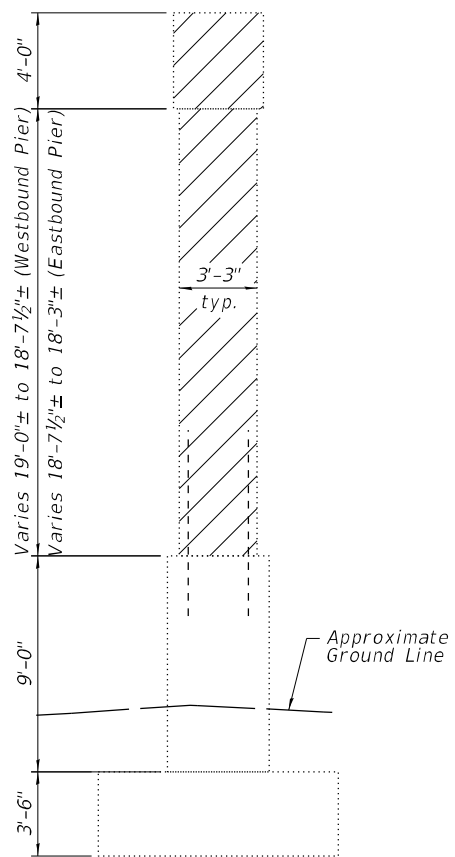

End View
(Looking East)

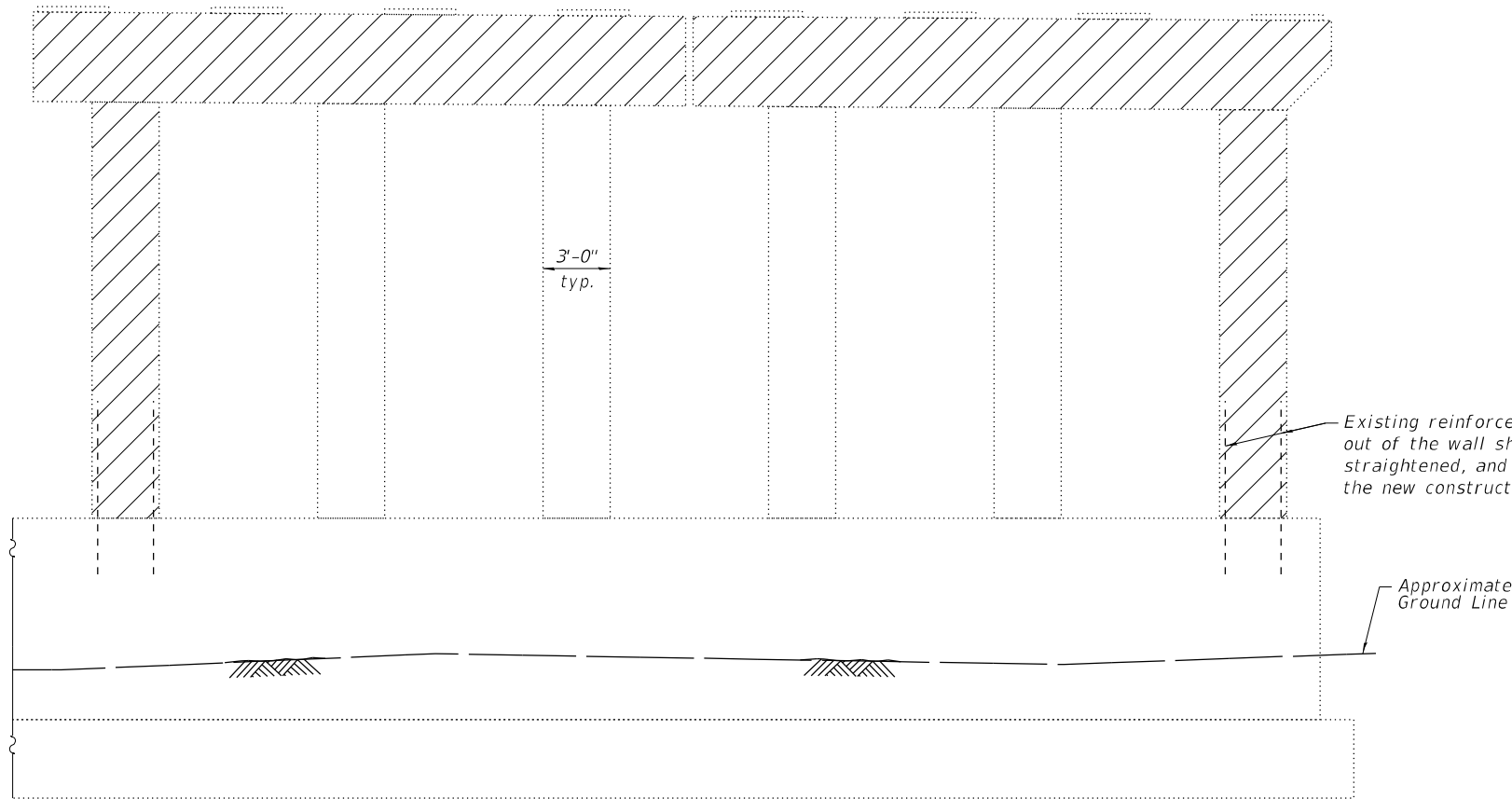

Elevation
(Looking North)
(Eastbound Structure Shown. Westbound Structure Similar)

Existing reinforcement extending out of the wall shall be cleaned, straightened, and incorporated into the new construction, typ.

Concrete Removal (Special)

Notes:
Removal of existing seismic retrofit retainer angles, existing restraint cables, and existing bearings are included in Concrete Removal (Special).
Seismic restraint cable brackets attached to girders are to remain.

BILL OF MATERIAL

ITEM	UNIT	QUANTITY
Concrete Removal (Special)	Cu. Yd.	90.1

MODEL: Default
FILE NAME: Z:\1505229_B&O_RR_Bridge\DCN\Bridg\final\Plotsheets\0820017-76K02-042-Pier_9_Substructure Removal.dgn

EFK•Moen
Civil Engineering Design

USER NAME = khill	DESIGNED - ACB	REVISED -
PLOT SCALE = 0.1667"/in.	CHECKED - CDL	REVISED -
PLOT DATE = 8/13/2024	DRAWN - ACB	REVISED -
	CHECKED - CDL	REVISED -

STATE OF ILLINOIS
DEPARTMENT OF TRANSPORTATION

SUBSTRUCTURE REMOVAL (PIER 9)
STRUCTURE NO. 082-0017

SHEET 42 OF 114 SHEETS

F.A.I. RTE.	SECTION	COUNTY	TOTAL SHEETS	SHEET NO.
55/70	82-5VB-R-2	ST. CLAIR	254	180
CONTRACT NO. 76K02				
ILLINOIS		FED. AID PROJECT		

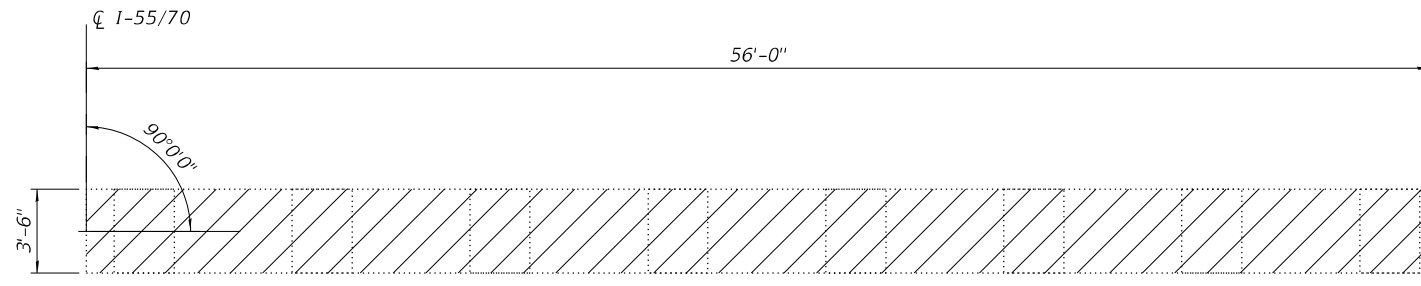

Plan

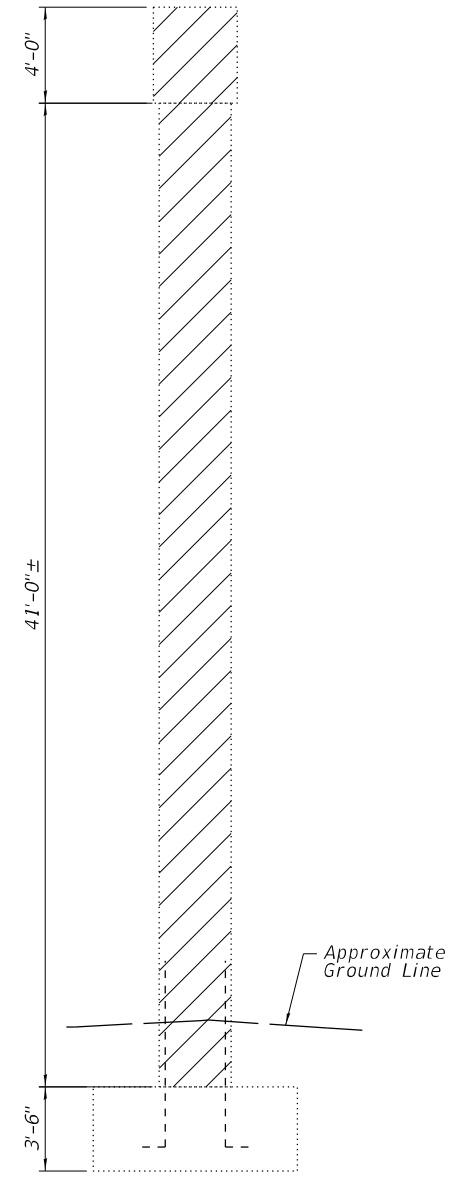
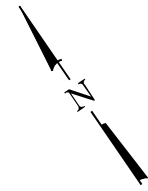

End View
(Looking East)

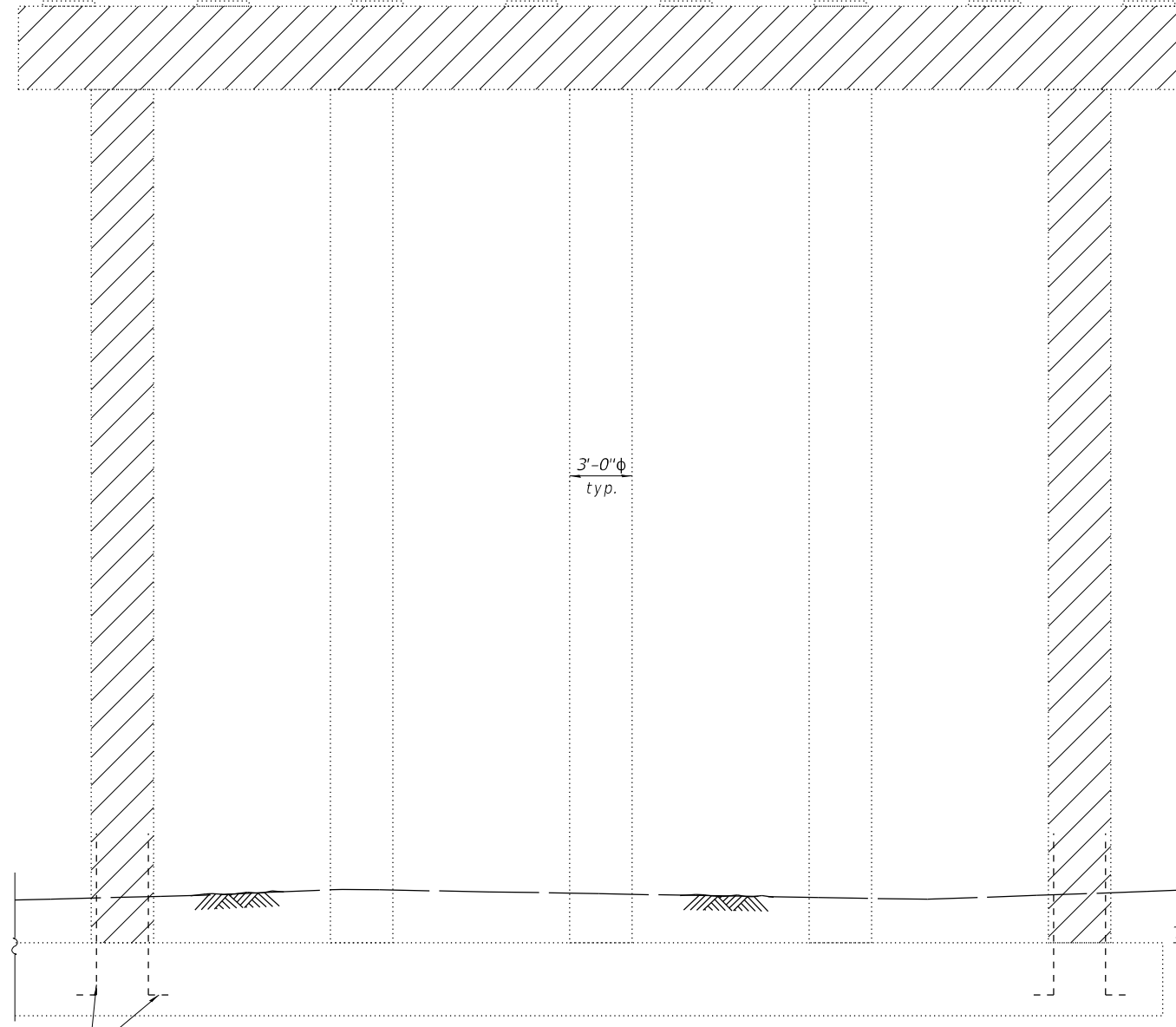

Elevation
(Looking North)

(Eastbound Structure Shown. Westbound Structure Similar)

Notes:
 Structure excavation, as required for concrete removal, shall be considered included in the contract unit price for "Concrete Removal (Special)".
 Removal of existing seismic retrofit retainer angles, existing restraint cables, and existing bearings are included in Concrete Removal (Special).
 Seismic restraint cable brackets attached to girders are to remain.

Concrete Removal (Special)

BILL OF MATERIAL

ITEM	UNIT	QUANTITY
Concrete Removal (Special)	Cu. Yd.	104.0

MODEL: Default
FILE NAME: Z:\1505229_B&O_RR_Bridge\Bridg\final\Plotsheets\0820017-76K02-043-Pier 10_Substructure_Removal.dgn

EFK•Moen
Civil Engineering Design

USER NAME = khill	DESIGNED - ACB	REVISED -
PLOT SCALE = 0.1667"/in.	CHECKED - CDL	REVISED -
PLOT DATE = 8/13/2024	DRAWN - ACB	REVISED -
	CHECKED - CDL	REVISED -

STATE OF ILLINOIS
DEPARTMENT OF TRANSPORTATION

SUBSTRUCTURE REMOVAL (PIER 10)
STRUCTURE NO. 082-0017

SHEET 43 OF 114 SHEETS

F.A.I. RTE.	SECTION	COUNTY	TOTAL SHEETS	SHEET NO.
55/70	82-5VB-R-2	ST. CLAIR	254	181
CONTRACT NO. 76K02				
		ILLINOIS	FED. AID PROJECT	

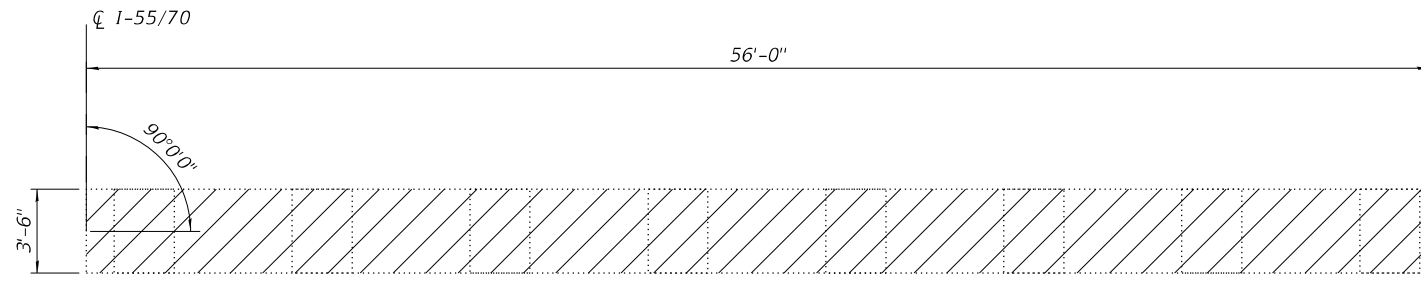

Plan

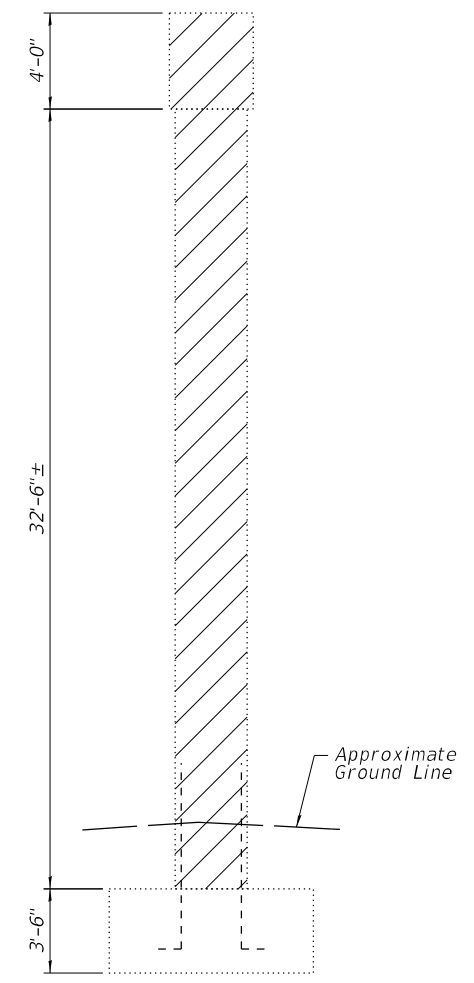

End View
(Looking East)

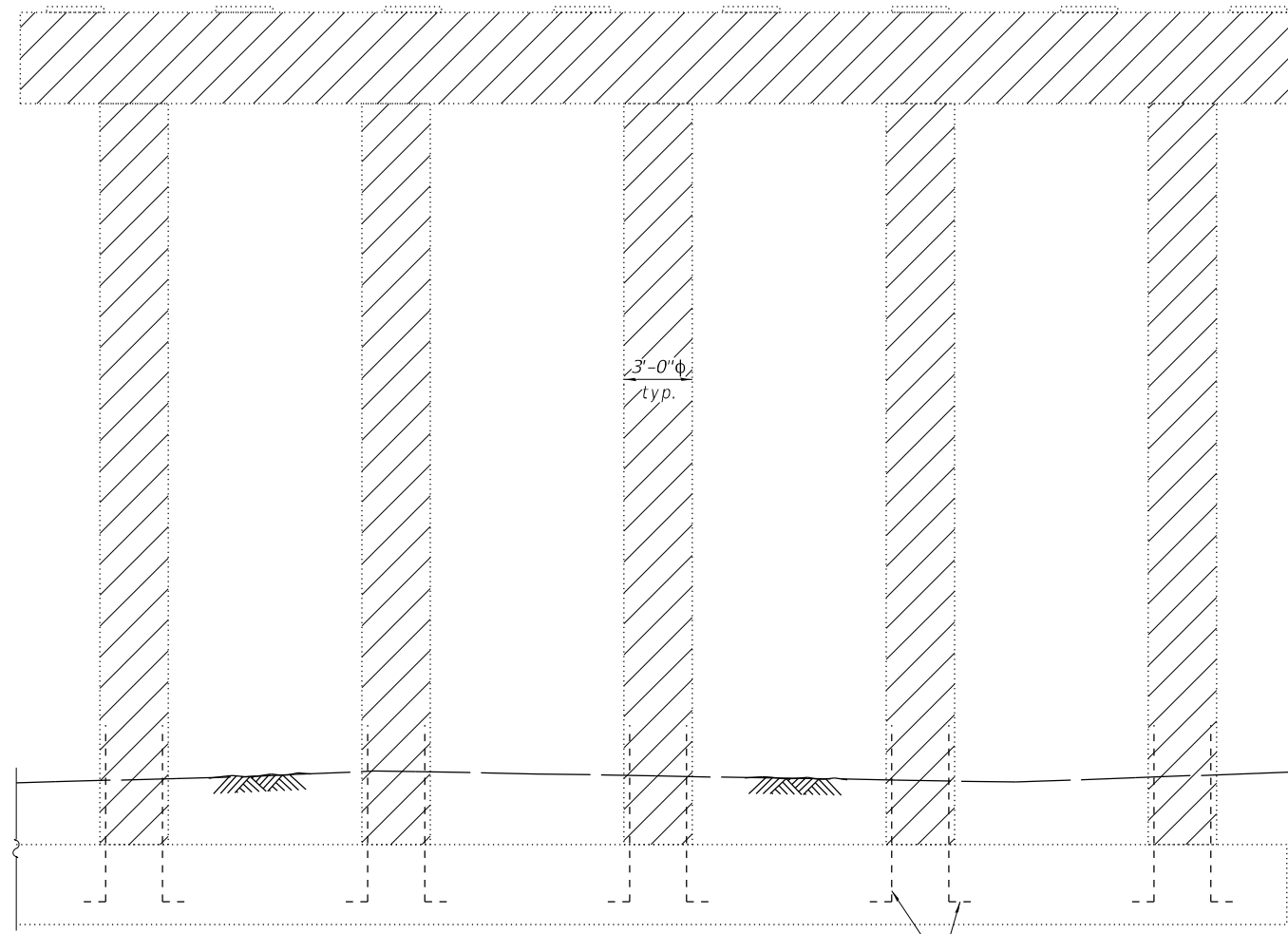

Elevation
(Looking North)
(Eastbound Structure Shown. Westbound Structure Similar)

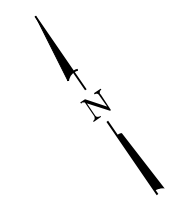

Notes:
 Structure excavation, as required for concrete removal, shall be considered included in the contract unit price for "Concrete Removal (Special)".
 Removal of existing seismic retrofit retainer angles, existing restraint cables, and existing bearings are included in Concrete Removal (Special).
 Seismic restraint cable brackets attached to girders are to remain.

Concrete Removal (Special)

BILL OF MATERIAL

ITEM	UNIT	QUANTITY
Concrete Removal (Special)	Cu. Yd.	146.1

MODEL: Default
FILE NAME: Z:\15052.29 B&O RR Bridge\DCN\Bridg\final\Plotsheets\0820017-76K02-044-Pier 13 Substructure Removal.dgn



USER NAME = khill	DESIGNED - ACB	REVISED -
PLOT SCALE = 0.1667"/in.	CHECKED - CDL	REVISED -
PLOT DATE = 8/13/2024	DRAWN - ACB	REVISED -
	CHECKED - CDL	REVISED -

**STATE OF ILLINOIS
DEPARTMENT OF TRANSPORTATION**

**SUBSTRUCTURE REMOVAL (PIER 13)
STRUCTURE NO. 082-0017**

SHEET 44 OF 114 SHEETS

F.A.I. RTE.	SECTION	COUNTY	TOTAL SHEETS	SHEET NO.
55/70	82-5VB-R-2	ST. CLAIR	254	182
CONTRACT NO. 76K02				
ILLINOIS		FED. AID PROJECT		

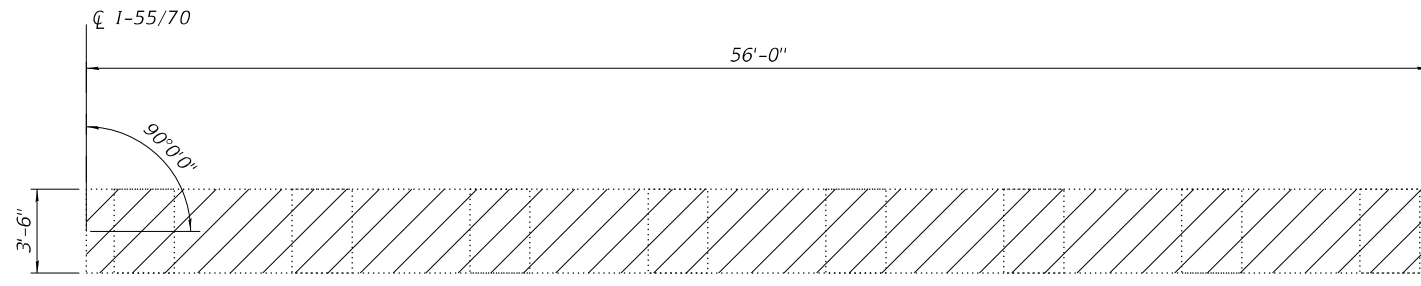

Plan

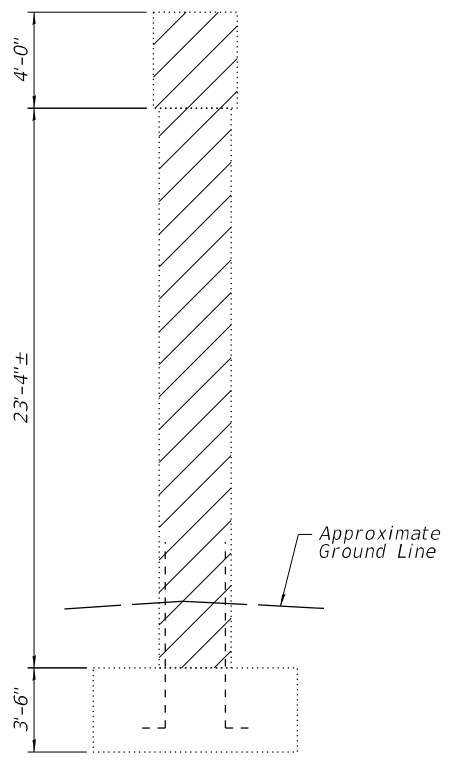
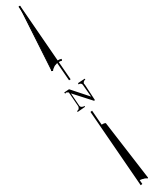

End View
(Looking East)

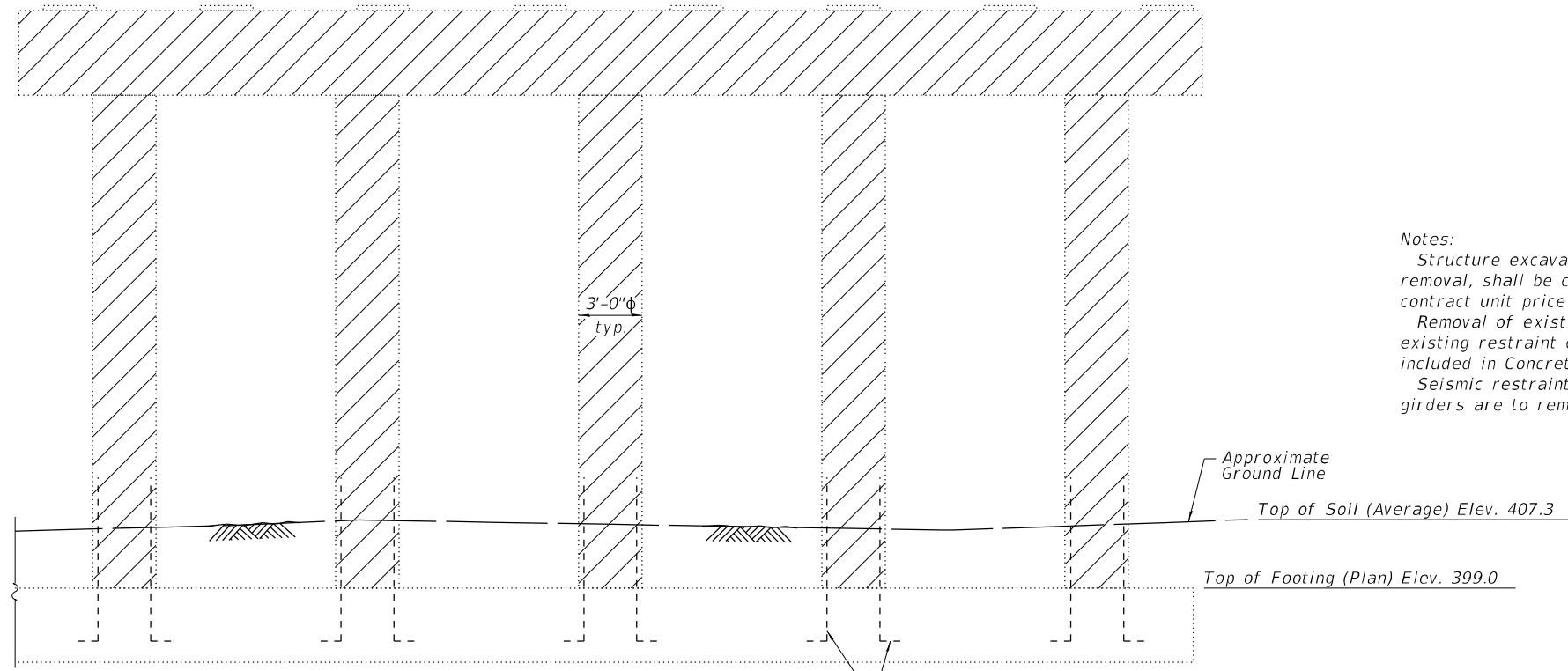

Elevation
(Looking North)
(Eastbound Structure Shown. Westbound Structure Similar)

Notes:
 Structure excavation, as required for concrete removal, shall be considered included in the contract unit price for "Concrete Removal (Special)".
 Removal of existing seismic retrofit retainer angles, existing restraint cables, and existing bearings are included in Concrete Removal (Special).
 Seismic restraint cable brackets attached to girders are to remain.

Concrete Removal (Special)

BILL OF MATERIAL

ITEM	UNIT	QUANTITY
Concrete Removal (Special)	Cu. Yd.	122.1

MODEL: Default
 FILE NAME: Z:\1505229_B&O_RR_Bridge\DCN\Bridg\final\Plotsheets\0820017-76K02-045-Pier_16_Substructure_Removal.dgn

EFK•Moen
 Civil Engineering Design

USER NAME = khill	DESIGNED - ACB	REVISED -
	CHECKED - CDL	REVISED -
PLOT SCALE = 0.1667"/in.	DRAWN - ACB	REVISED -
PLOT DATE = 8/13/2024	CHECKED - CDL	REVISED -

STATE OF ILLINOIS
DEPARTMENT OF TRANSPORTATION

SUBSTRUCTURE REMOVAL (PIER 16)
STRUCTURE NO. 082-0017

SHEET 45 OF 114 SHEETS

F.A.I. RTE.	SECTION	COUNTY	TOTAL SHEETS	SHEET NO.
55/70	82-5VB-R-2	ST. CLAIR	254	183
CONTRACT NO. 76K02				
ILLINOIS		FED. AID PROJECT		

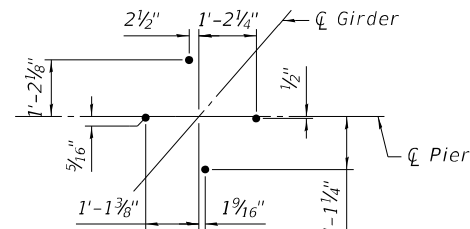

ANCHOR BOLT LAYOUT
Girders A-G

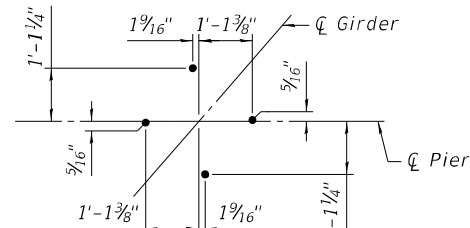

ANCHOR BOLT LAYOUT
Girder H

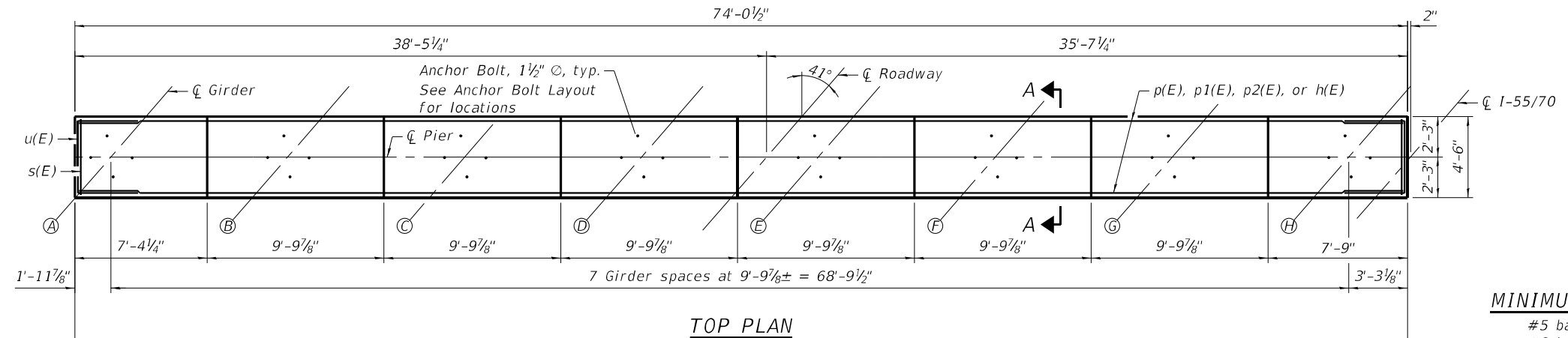

TOP PLAN

MINIMUM BAR LAP

#5 bars	= 2'-9"
#6 bars	= 3'-4"
#8 bars	= 5'-1"
#9 bars	= 6'-5"

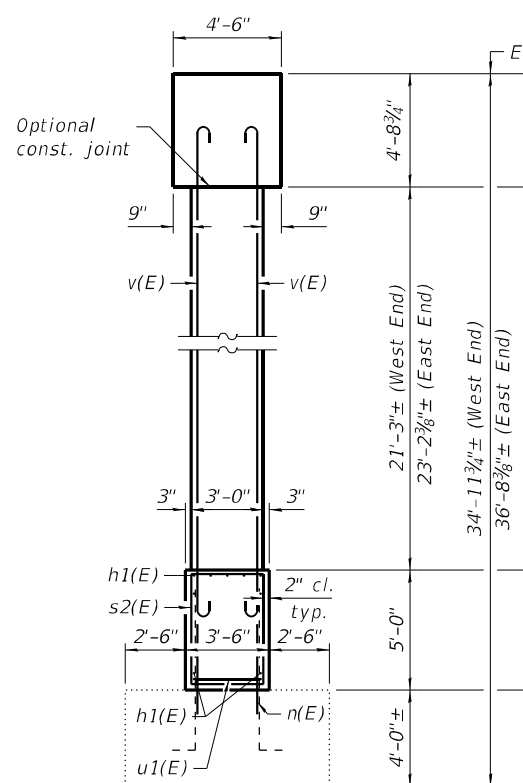

END VIEW
(Looking East)

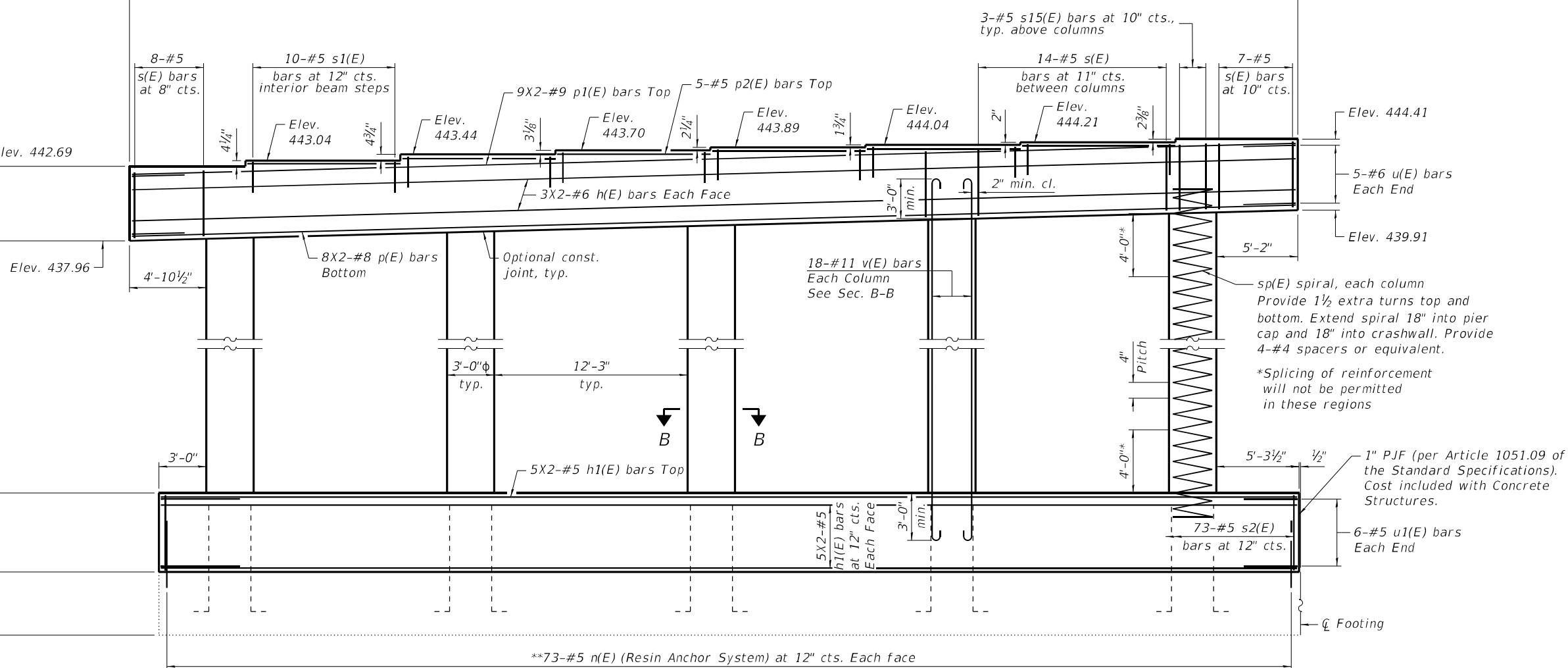

ELEVATION
(Looking North)

Notes:
Contractor shall adjust column heights in field after verifying footing elevation. Column heights can be adjusted up to 6" without notifying Engineer. If required to meet minimums shown, reinforcement lengths shall be increased.
All exposed surfaces of new concrete for the pier cap, columns, and wall shall be treated with Concrete Sealer.
Bars indicated thus 1x4-#8 etc. indicates 1 line of bars with 4 lengths per line.

**Epoxy grout n(E) bars according to Section 584 of the Standard Specifications. Minimum embedment is 12". Embedment depth may be reduced according to the epoxy Manufacturer, if the Contractor provides the Engineer in writing that the shallower embedment depth is capable of developing the full yield strength of the reinforcement at the surface of the existing concrete.

MODEL: Default
FILE NAME: Z:\15052229_B&O_RR_Bridge\DNV\Bridge\final\Plotsheets\0820017-76K02-046-Substructure_Replacement_Pier_3_WB.dgn
8/13/2024 9:41:46 AM

EFK•Moen Civil Engineering Design	USER NAME = khill	DESIGNED - ACB	REvised -	STATE OF ILLINOIS DEPARTMENT OF TRANSPORTATION	SUBSTRUCTURE REPLACEMENT (PIER 3 WB) STRUCTURE NO. 082-0017	F.A.I. RTE. = 5570	SECTION = 82-5VB-R-2	COUNTY = ST. CLAIR	TOTAL SHEETS = 254	SHEET NO. = 184
	PLOT SCALE = 0.1667"/in.	DRAWN - ACB	REvised -			CONTRACT NO. 76K02				
	PLOT DATE = 8/13/2024	CHECKED - CDL	REvised -	SHEET 46 OF 114 SHEETS			ILLINOIS FED. AID PROJECT			

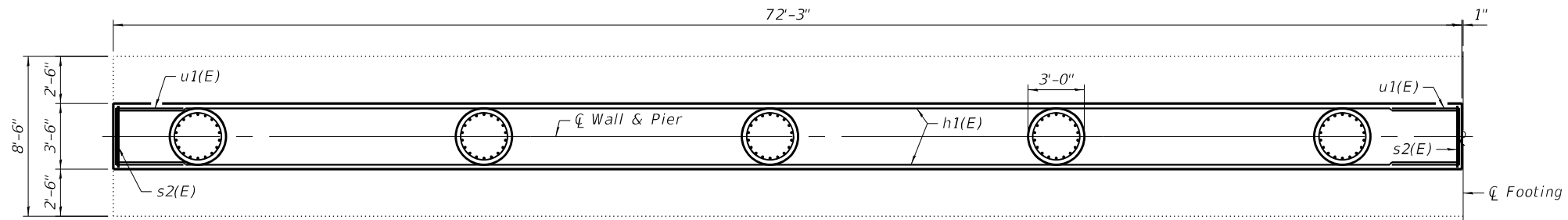

FOOTING PLAN

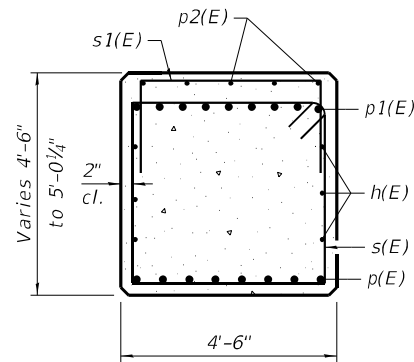

SECTION A-A

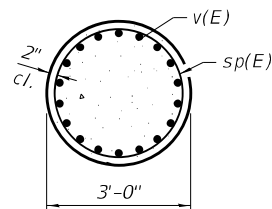

SECTION B-B

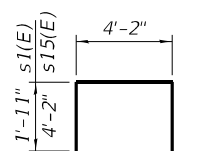

BAR s1(E)
& s15(E)

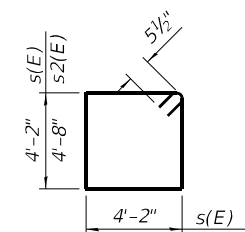

BAR s(E)
& s2(E)

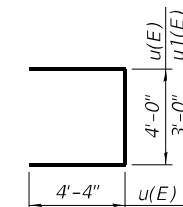

BAR u(E)
& u1(E)

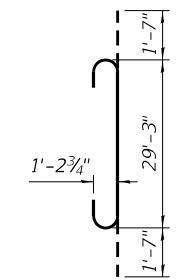

BAR v(E)

BILL OF MATERIAL

Bar	No.	Size	Length	Shape
h(E)	12	#6	38'-7"	—
h1(E)	30	#5	37'-5"	—
n(E)	146	#5	4'-3"	—
p(E)	16	#8	39'-5"	—
p1(E)	18	#9	40'-1"	—
p2(E)	30	#5	9'-8"	—
s(E)	71	#5	17'-7"	□
s1(E)	60	#5	8'-0"	U
s2(E)	73	#5	16'-7"	□
s15(E)	15	#5	12'-6"	U
* sp(E)	5	#5	26'-3"	W
u(E)	10	#6	12'-8"	U
u1(E)	12	#5	10'-2"	U
v(E)	90	#11	32'-5"	C
Concrete Structures			Cu. Yd.	134.6
Reinforcement Bars, Epoxy Coated			Pound	29,540
Concrete Sealer			Sq. Ft.	2,431

* Length is height of spiral.

MODEL: Default
FILE NAME: Z:\15052229_B&O RR Bridge\DCN\Bridg\final\Plotsheets\0820017-76K02-047-Substructure_Replacement_Pier_3 (WB).dgn

USER NAME = khill	DESIGNED - ACB	REVISED -
PLOT SCALE = 02" / ft.	CHECKED - CDL	REVISED -
PLOT DATE = 8/13/2024	DRAWN - ACB	REVISED -
	CHECKED - CDL	REVISED -

F.A.I. RTE.	SECTION	COUNTY	TOTAL SHEETS	SHEET NO.
55/70	82-SVB-R-2	ST. CLAIR	254	185
CONTRACT NO. 76K02				
ILLINOIS		FED. AID PROJECT		

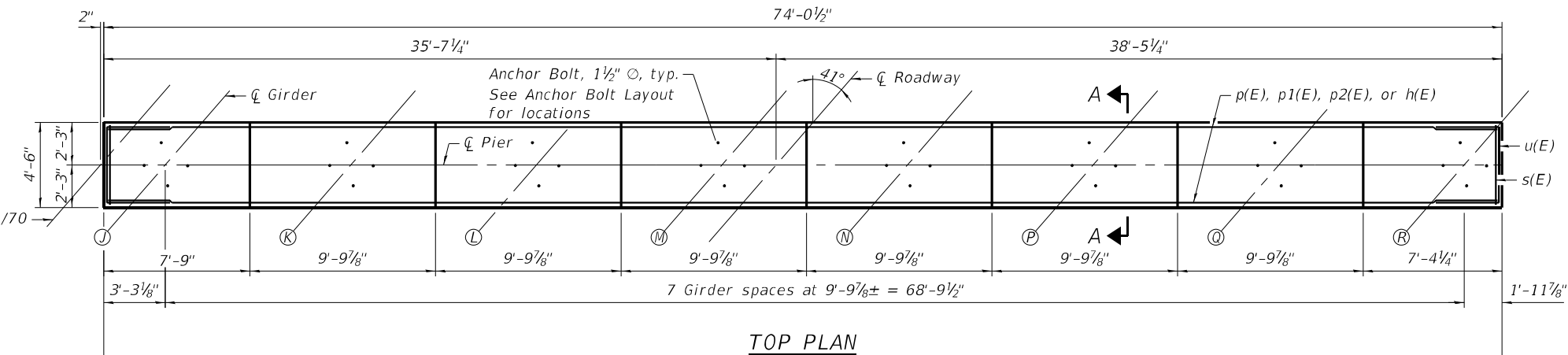
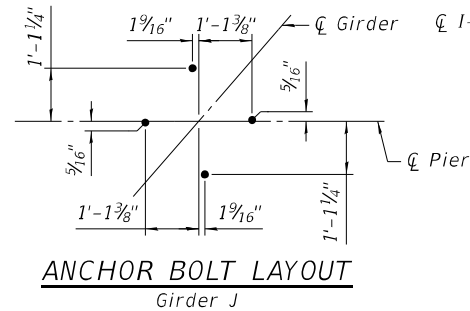
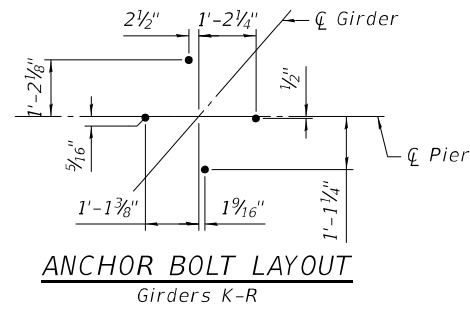

MINIMUM BAR LAP
 #5 bars = 2'-9"
 #6 bars = 3'-4"
 #8 bars = 5'-1"
 #9 bars = 6'-5"

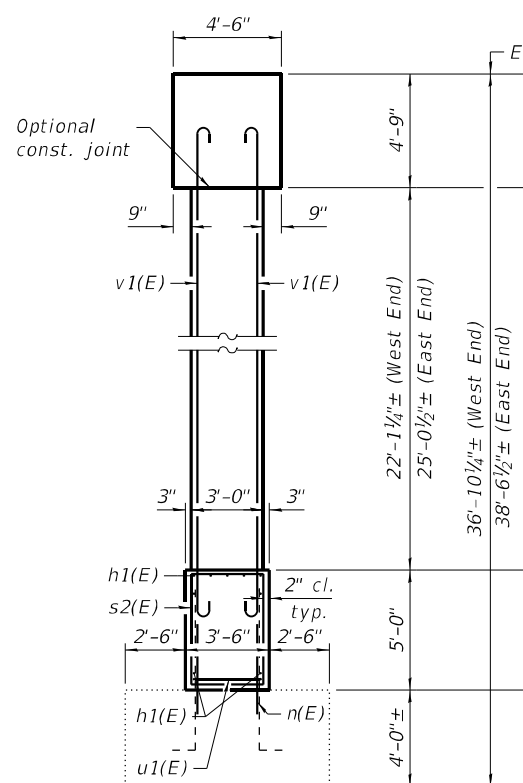
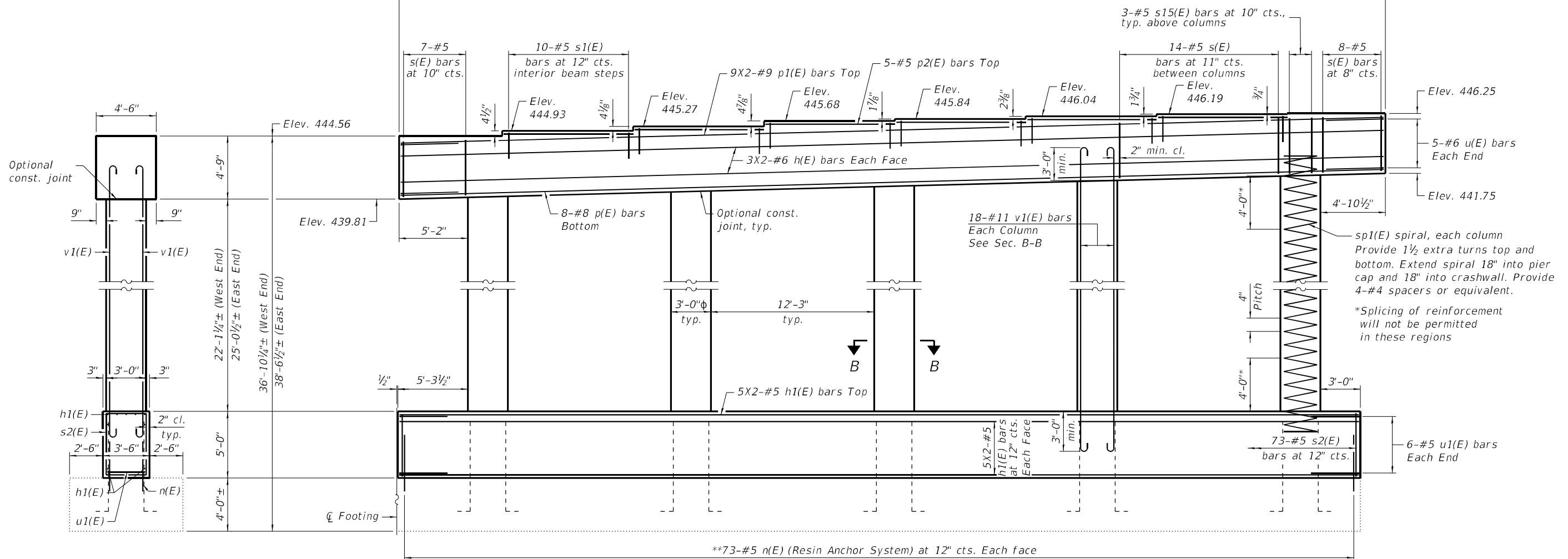

**Epoxy grout n(E) bars according to Section 584 of the Standard Specifications. Minimum embedment is 12". Embedment depth may be reduced according to the epoxy Manufacturer, if the Contractor provides the Engineer in writing that the shallower embedment depth is capable of developing the full yield strength of the reinforcement at the surface of the existing concrete.

Notes:
 Contractor shall adjust column heights in field after verifying footing elevation. Column heights can be adjusted up to 6" without notifying Engineer. If required to meet minimums shown, reinforcement lengths shall be increased.
 All exposed surfaces of new concrete for the pier cap, columns, and wall shall be treated with Concrete Sealer.
 Bars indicated thus 1x4-#8 etc. indicates 1 line of bars with 4 lengths per line.

MODEL: Default
 FILE NAME: Z:\15052229_B&O_RR_Bridge\DCN\Bridg\final\Plotsheets\082001776K02-04B-Substructure_Replacement_Pier_3_(EB).dgn
 8/13/2024 9:41:47 AM

EFK•Moen Civil Engineering Design	USER NAME = khill	DESIGNED - ACB	REVISED -	STATE OF ILLINOIS DEPARTMENT OF TRANSPORTATION	SUBSTRUCTURE REPLACEMENT (PIER 3 EB) STRUCTURE NO. 082-0017	F.A.I. RTE. = 5570	SECTION = 82-5VB-R-2	COUNTY = ST. CLAIR	TOTAL SHEETS = 254	SHEET NO. = 186
	PLOT SCALE = 0.1667"/in.	DRAWN - ACB	REVISED -			SHEET 48 OF 114 SHEETS	CONTRACT NO. 76K02		ILLINOIS	FED. AID PROJECT
	PLOT DATE = 8/13/2024	CHECKED - CDL	REVISED -							

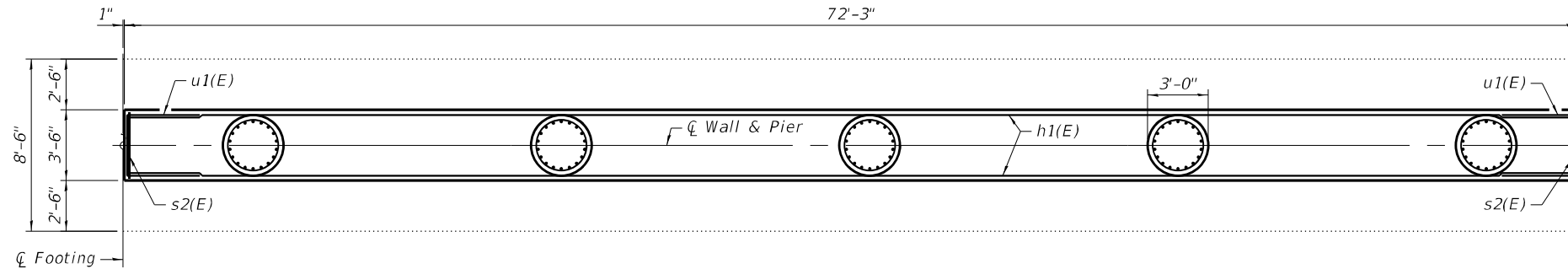

FOOTING PLAN

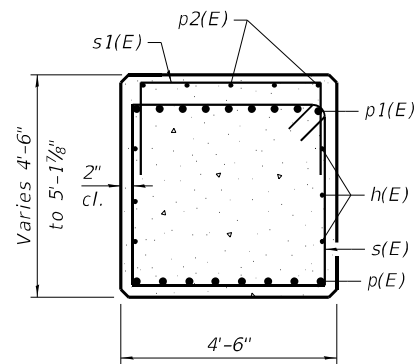

SECTION A-A

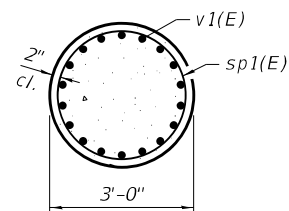

SECTION B-B

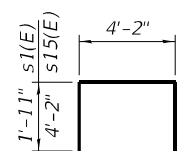

BAR s1(E)
& s15(E)

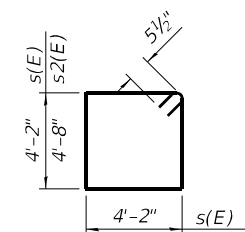

BAR s(E)
& s2(E)

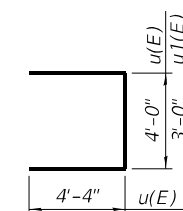

BAR u(E)
& u1(E)

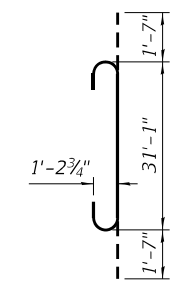

BAR v1(E)

BILL OF MATERIAL

Bar	No.	Size	Length	Shape
h(E)	12	#6	38'-7"	—
h1(E)	30	#5	37'-5"	—
n(E)	146	#5	4'-3"	—
p(E)	16	#8	39'-5"	—
p1(E)	18	#9	40'-1"	—
p2(E)	30	#5	9'-8"	—
s(E)	71	#5	17'-7"	□
s1(E)	60	#5	8'-0"	U
s2(E)	73	#5	16'-7"	□
s15(E)	15	#5	12'-6"	U
* sp1(E)	5	#5	28'-1"	W
u(E)	10	#6	12'-8"	U
u1(E)	12	#5	10'-2"	U
v1(E)	90	#11	34'-3"	C
Concrete Structures			Cu. Yd.	137.8
Reinforcement Bars, Epoxy Coated			Pound	30,650
Concrete Sealer			Sq. Ft.	2,518

* Length is height of spiral.

MODEL: Default
FILE NAME: Z:\1505229_B&O RR Bridge\DCN\Bridg\final\Plotsheets\0820017-76K02-049-Substructure_Replacement_Pier_3 (EB).dgn

EFK Moen
Civil Engineering Design

USER NAME = khill	DESIGNED - ACB	REVISED -
PLOT SCALE = 0.1667"/in.	CHECKED - CDL	REVISED -
PLOT DATE = 8/13/2024	DRAWN - ACB	REVISED -
	CHECKED - CDL	REVISED -

STATE OF ILLINOIS
DEPARTMENT OF TRANSPORTATION

SUBSTRUCTURE REPLACEMENT (PIER 3 EB)
STRUCTURE NO. 082-0017

SHEET 49 OF 114 SHEETS

F.A.I. RTE.	SECTION	COUNTY	TOTAL SHEETS	SHEET NO.
55/70	82-SVB-R-2	ST. CLAIR	254	187
CONTRACT NO. 76K02				
ILLINOIS		FED. AID PROJECT		

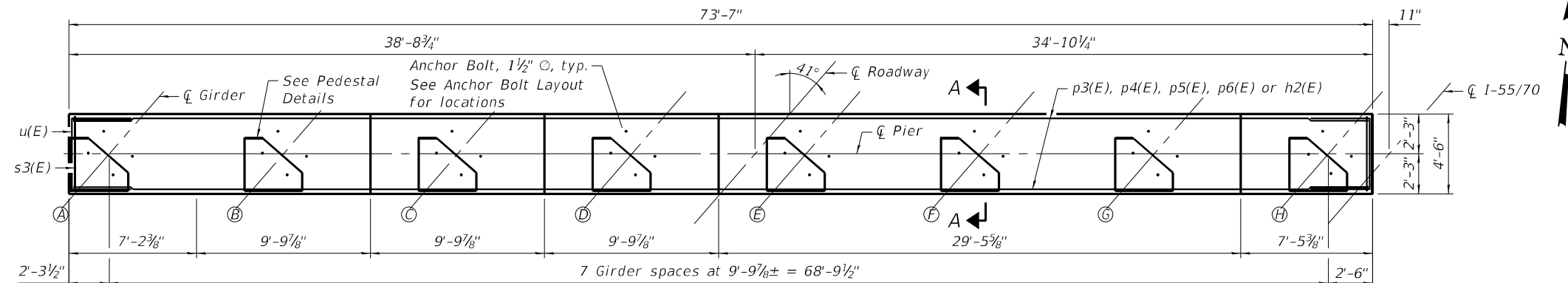
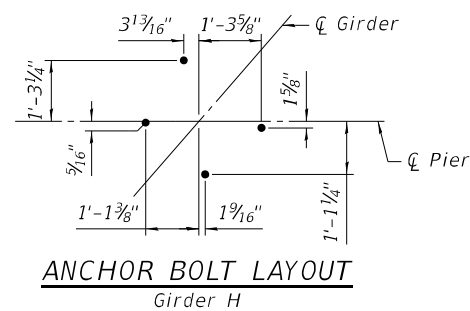
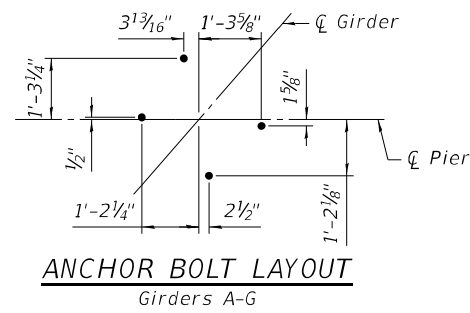

MINIMUM BAR LAP
 #5 bars = 2'-9"
 #6 bars = 3'-4"
 #8 bars = 5'-9"

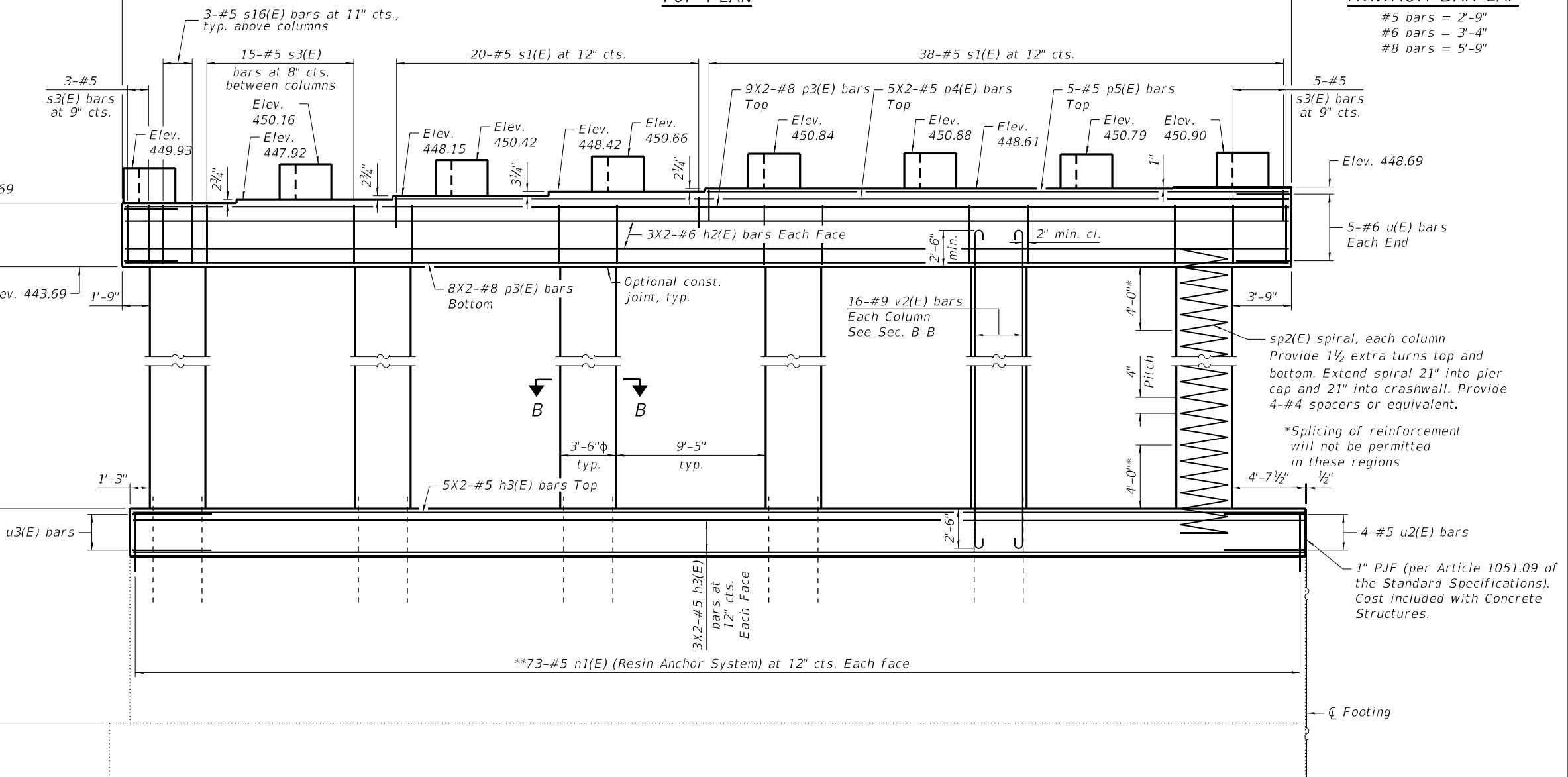
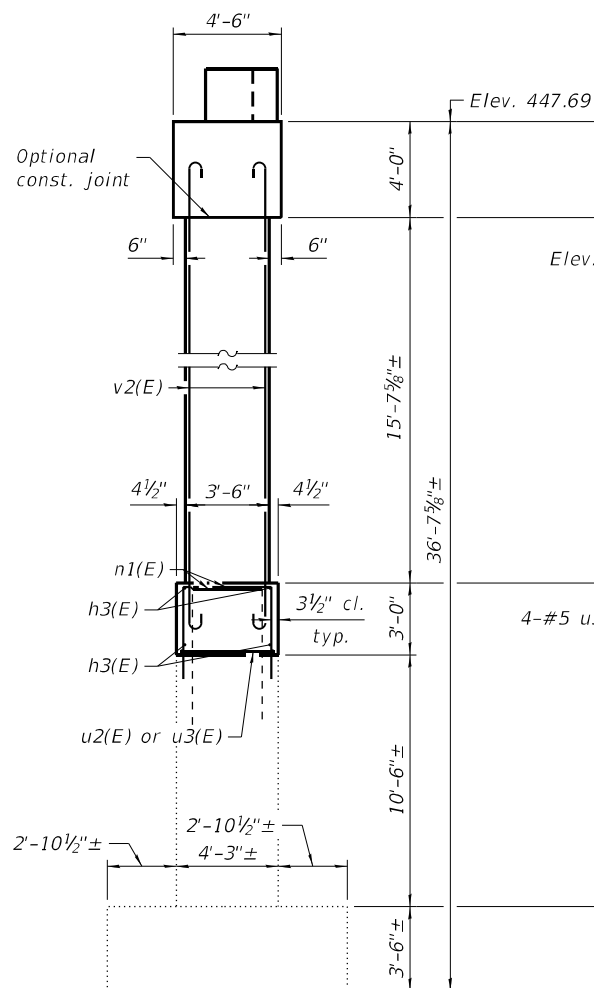

**Epoxy grout n1(E) bars according to Section 584 of the Standard Specifications. Minimum embedment is 12". Embedment depth may be reduced according to the epoxy Manufacturer, if the Contractor provides the Engineer in writing that the shallower embedment depth is capable of developing the full yield strength of the reinforcement at the surface of the existing concrete.

Note:
 Contractor shall adjust column heights in field after verifying wall elevation. Column heights can be adjusted up to 6" without notifying Engineer. If required to meet minimums shown, reinforcement lengths shall be increased.
 Protective Coat (Special) shall be applied to new concrete pedestals. All other exposed surfaces of new concrete for the pier cap, columns, and wall shall be treated with Concrete Sealer.
 Bars indicated thus 1x4-#8 etc. indicates 1 line of bars with 4 lengths per line.

MODEL: Default
 FILE NAME: Z:\1505229_B&O RR Bridge\DNV\Bridge\final\Plotsheets\082001776K02-050-Substructure- Replacement Pier 6 (WB).dgn
 8/13/2024 9:41:49 AM

EFK Moen Civil Engineering Design	USER NAME = khill	DESIGNED - ACB	REVISED -	STATE OF ILLINOIS DEPARTMENT OF TRANSPORTATION	SUBSTRUCTURE REPLACEMENT (PIER 6 WB) STRUCTURE NO. 082-0017	F.A.I. RTE. = 55/70	SECTION = 82-5VB-R-2	COUNTY = ST. CLAIR	TOTAL SHEETS = 254	SHEET NO. = 188
	PLOT SCALE = 0.1667"/in.	DRAWN - ACB	REVISED -			SHEET 50 OF 114 SHEETS	CONTRACT NO. 76K02		ILLINOIS	FED. AID PROJECT
	PLOT DATE = 8/13/2024	CHECKED - CDL	REVISED -							

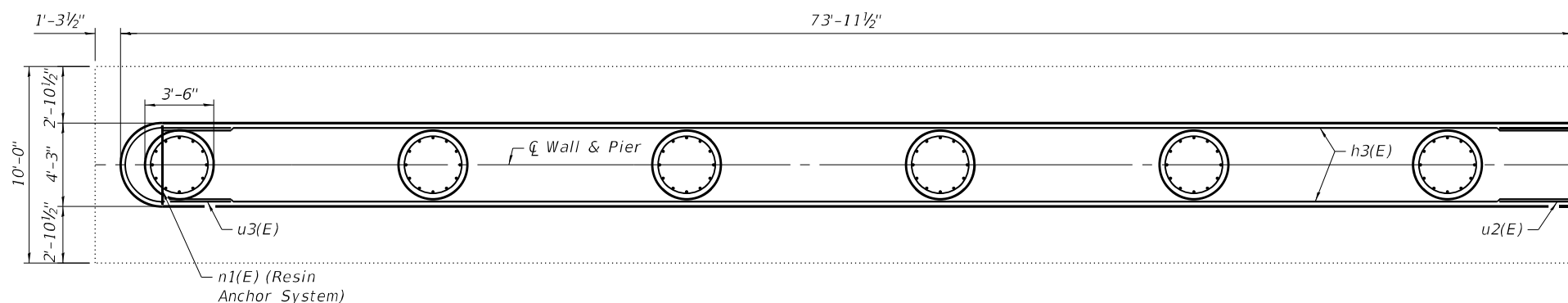

FOOTING PLAN

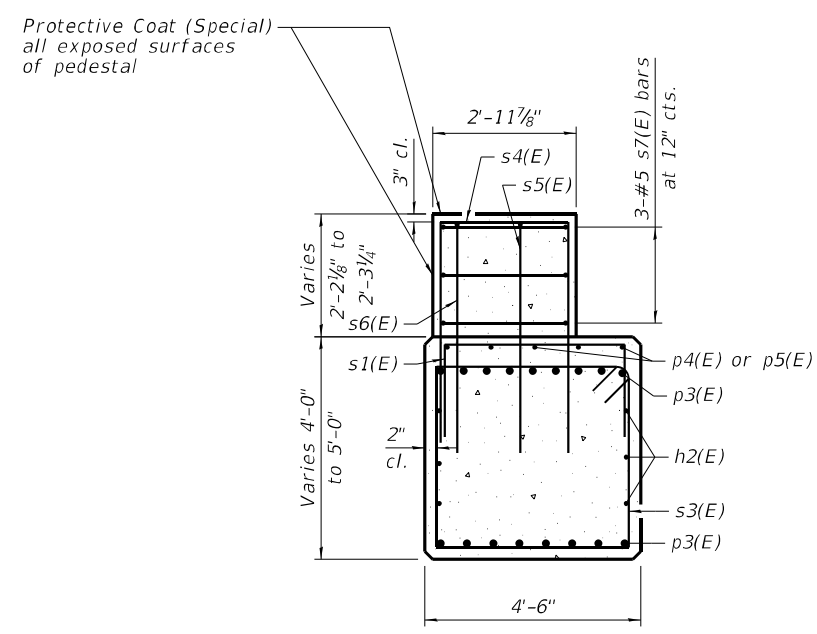

SECTION A-A

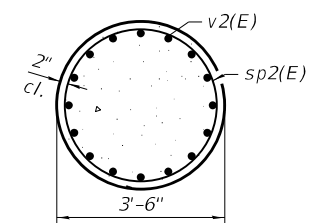

SECTION B-B

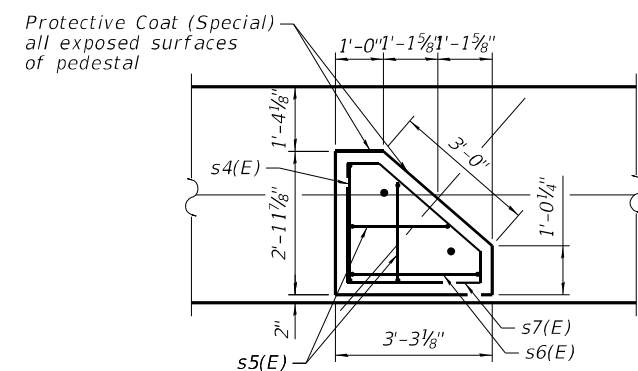

PEDESTAL DETAIL

Provide minimum 2.5" clear cover around all reinforcement in pedestal. Concrete Sealer applied to pier cap only. Protect pedestals from overspray.

Bar	A	B
s1(E)	1'-11"	4'-2"
s4(E)	4'-5"	2'-6"
s5(E)	4'-5"	2'-1"
s6(E)	4'-5"	2'-7"
s16(E)	3'-8"	4'-2"

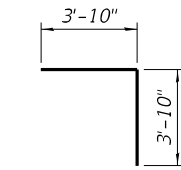

BAR n1(E)

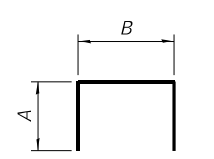

BAR s1(E), s4(E) thru s6(E) & s16(E)

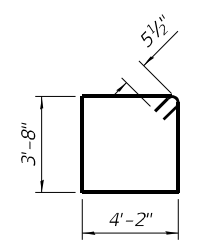

BAR s3(E)

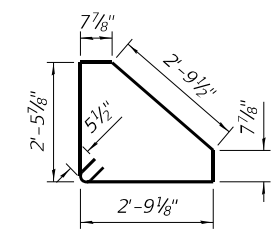

BAR s7(E)

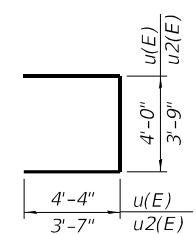

BAR u(E) & u2(E)

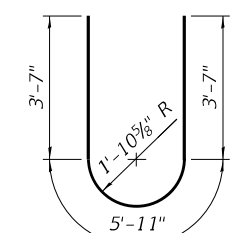

BAR u3(E)

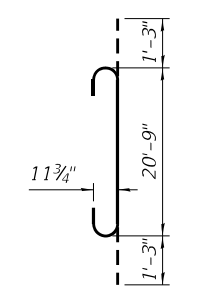

BAR v2(E)

BILL OF MATERIAL

Bar	No.	Size	Length	Shape
h2(E)	12	#6	38'-0"	—
h3(E)	22	#5	37'-3"	—
n1(E)	146	#5	7'-8"	┌
p3(E)	34	#8	39'-6"	—
p4(E)	10	#5	29'-6"	—
p5(E)	5	#5	36'-7"	—
s1(E)	58	#5	8'-0"	┌
s3(E)	83	#5	16'-7"	┌
s4(E)	8	#5	11'-4"	┌
s5(E)	16	#5	10'-11"	┌
s6(E)	8	#5	11'-5"	┌
s7(E)	24	#5	10'-4"	┌
s16(E)	18	#5	11'-6"	┌
sp2(E)	6	#5	19'-2"	⋈
u(E)	10	#6	12'-8"	┌
u2(E)	4	#5	10'-11"	┌
u3(E)	4	#5	13'-1"	┌
v2(E)	96	#9	23'-3"	┌
Concrete Structures			Cu. Yd.	130.5
Reinforcement Bars, Epoxy Coated			Pound	26,110
Concrete Sealer Protective Coat (Special)			Sq. Ft.	3,009
			Sq. Yd.	34

* Length is height of spiral.

MODEL: Default
FILE NAME: Z:\15052229_B&O RR Bridge\DCN\Bridg\final\Plotsheets\0820017-76K02-051-Substructure_Replacement_Pier 6 (WB).dgn
8/13/2024 9:41:50 AM

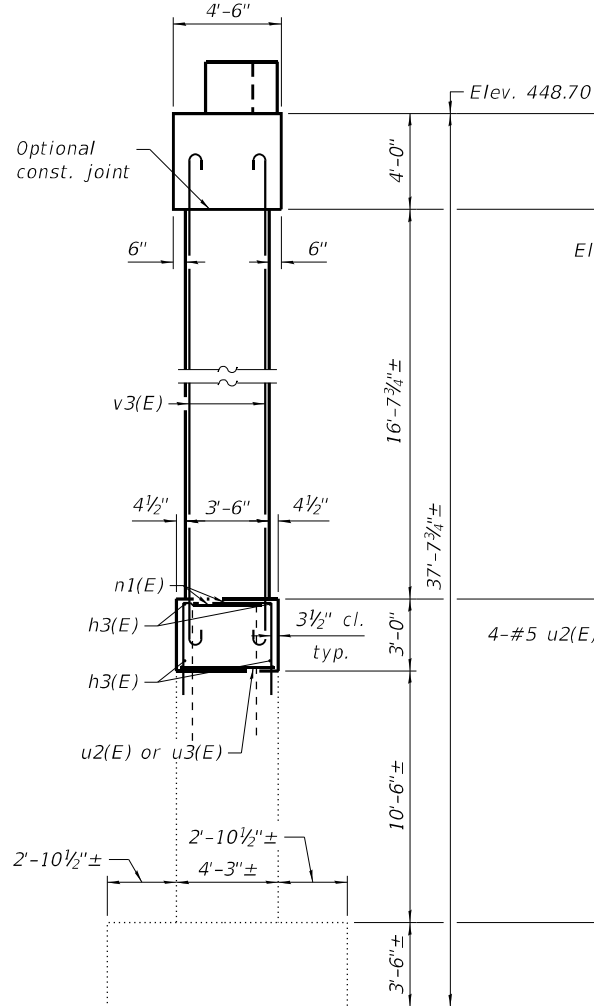
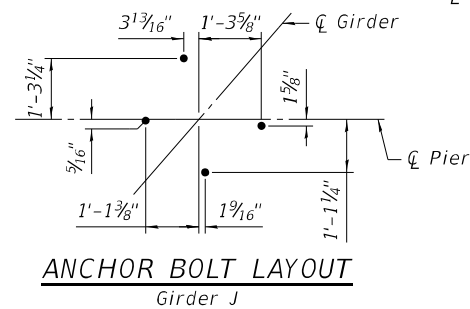
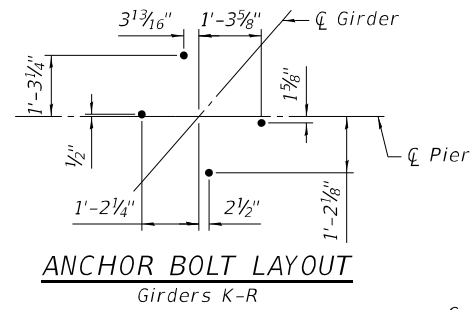

END VIEW
(Looking East)

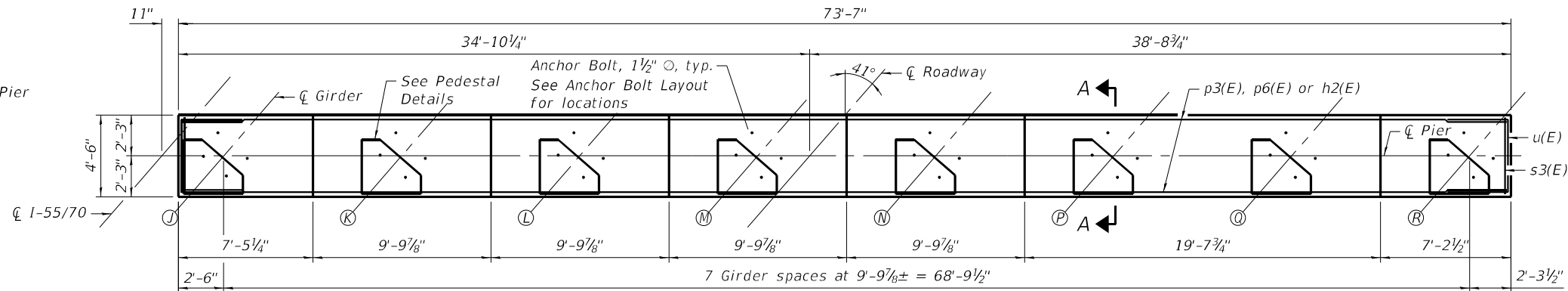

TOP PLAN

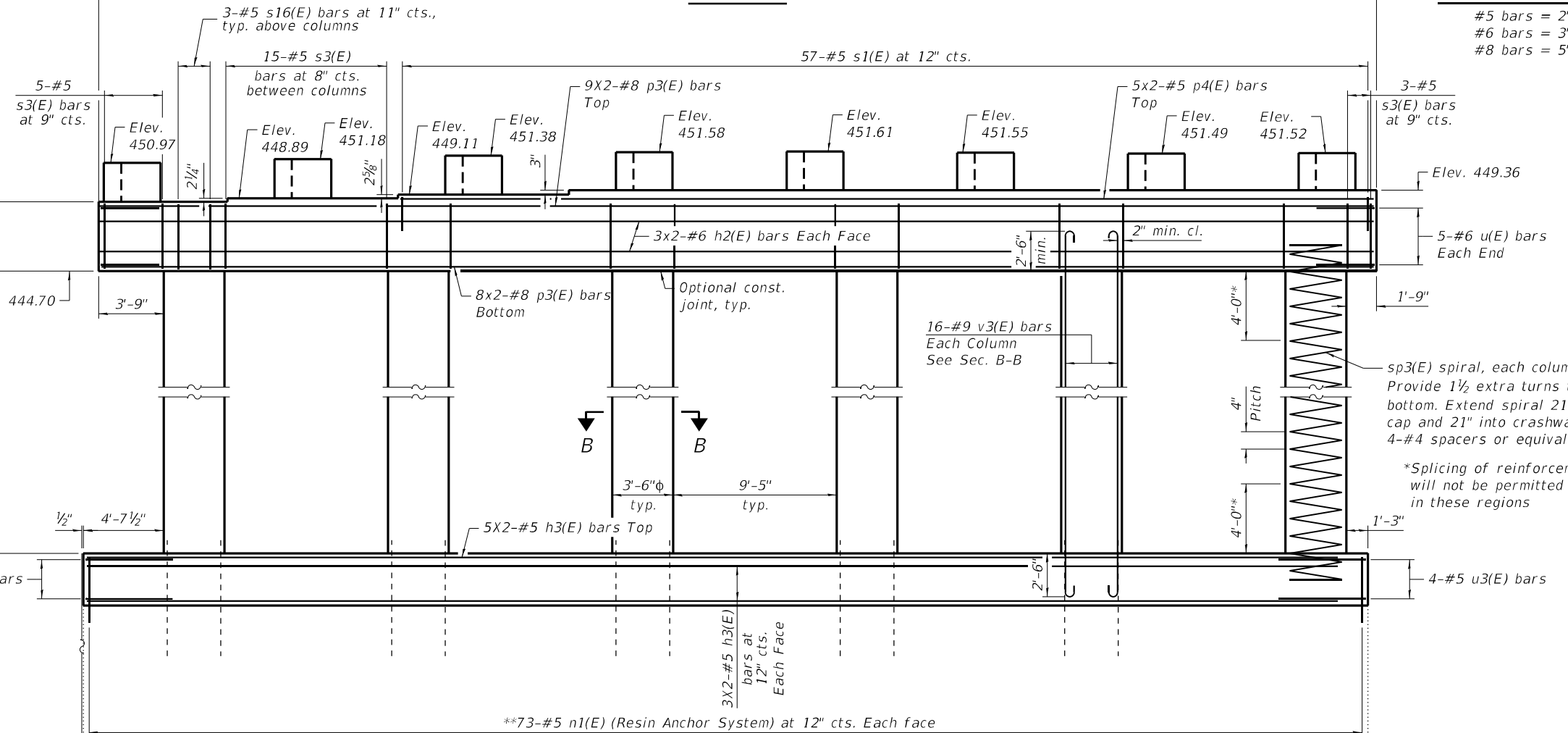

ELEVATION
(Looking North)

MINIMUM BAR LAP

- #5 bars = 2'-9"
- #6 bars = 3'-4"
- #8 bars = 5'-9"

**Epoxy grout n1(E) bars according to Section 584 of the Standard Specifications. Minimum embedment is 12". Embedment depth may be reduced according to the epoxy Manufacturer, if the Contractor provides the Engineer in writing that the shallower embedment depth is capable of developing the full yield strength of the reinforcement at the surface of the existing concrete.

Note:
Contractor shall adjust column heights in field after verifying wall elevation. Column heights can be adjusted up to 6" without notifying Engineer. If required to meet minimums shown, reinforcement lengths shall be increased.
Protective Coat (Special) shall be applied to new concrete pedestals. All other exposed surfaces of new concrete for the pier cap, columns, and wall shall be treated with Concrete Sealer.
Bars indicated thus 1x4-#8 etc. indicates 1 line of bars with 4 lengths per line.

MODEL: Default
FILE NAME: Z:\1505229_B&O RR Bridge\DCN\Bridg\final\Plotsheets\0820017-76K02-052-Substructure Replacement Pier 6 (EB).dgn

EFK Moen
Civil Engineering Design

USER NAME = khill	DESIGNED - ACB	REVISED -
PLOT SCALE = 0.1667"/in.	CHECKED - CDL	REVISED -
PLOT DATE = 8/13/2024	DRAWN - ACB	REVISED -
	CHECKED - CDL	REVISED -

STATE OF ILLINOIS
DEPARTMENT OF TRANSPORTATION

SUBSTRUCTURE REPLACEMENT (PIER 6 EB)
STRUCTURE NO. 082-0017

SHEET 52 OF 114 SHEETS

F.A.I. RTE.	SECTION	COUNTY	TOTAL SHEETS	SHEET NO.
55/70	82-5VB-R-2	ST. CLAIR	254	190
CONTRACT NO. 76K02				
ILLINOIS		FED. AID PROJECT		

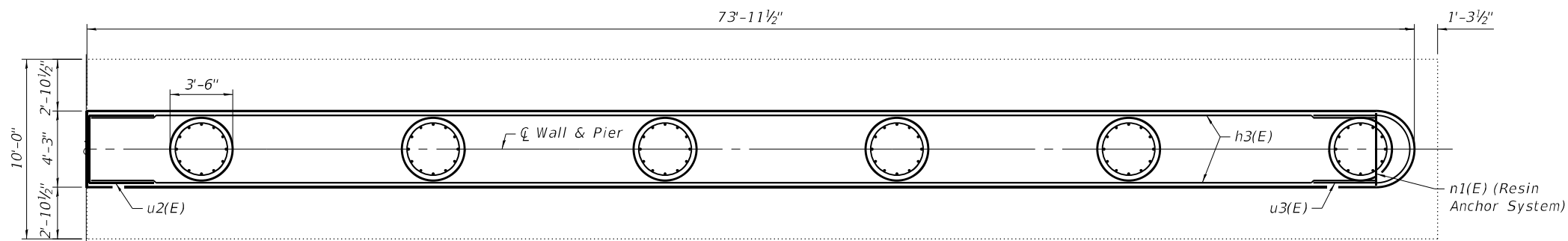

FOOTING PLAN

Protective Coat (Special)
all exposed surfaces
of pedestal

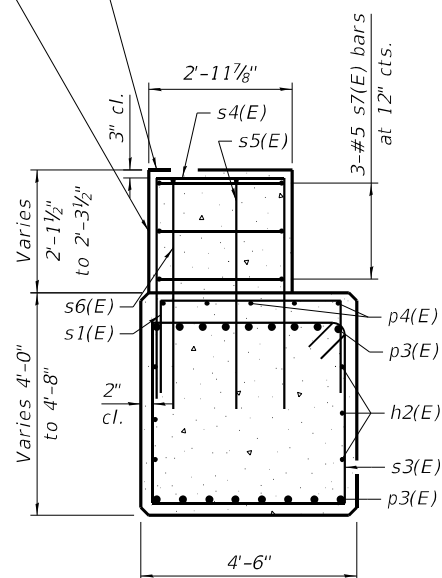

SECTION A-A

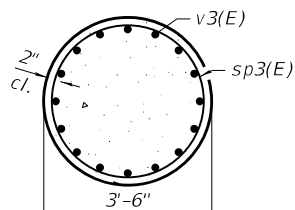

SECTION B-B

Protective Coat (Special)
all exposed surfaces
of pedestal

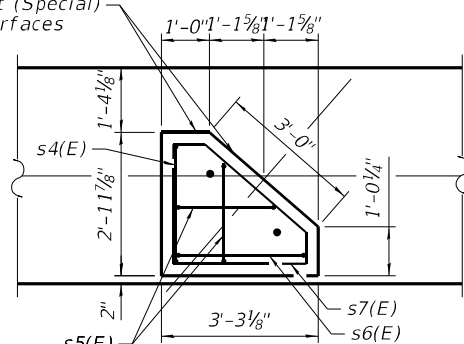

PEDESTAL DETAIL

Provide minimum 2.5" clear cover
around all reinforcement in pedestal.
Concrete Sealer applied to pier cap
only. Protect pedestals from overspray.

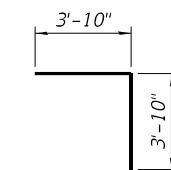

BAR n1(E)

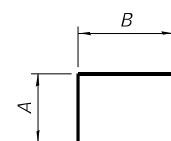

**BAR s1(E),
s4(E) thru s6(E)
& s16(E)**

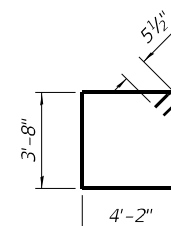

BAR s3(E)

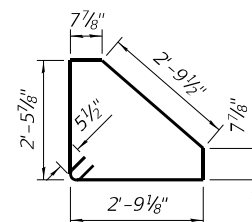

BAR s7(E)

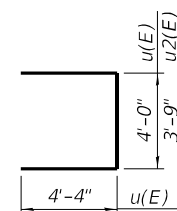

**BAR u(E)
& u2(E)**

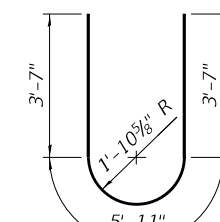

BAR u3(E)

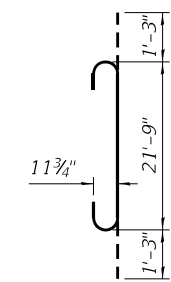

BAR v3(E)

Bar	A	B
s1(E)	1'-11"	4'-2"
s4(E)	4'-5"	2'-6"
s5(E)	4'-5"	2'-1"
s6(E)	4'-5"	2'-7"
s16(E)	3'-8"	4'-2"

BILL OF MATERIAL

Bar	No.	Size	Length	Shape
h2(E)	12	#6	38'-0"	—
h3(E)	22	#5	37'-3"	—
n1(E)	146	#5	7'-8"	└
p3(E)	34	#8	39'-6"	—
p4(E)	10	#5	29'-6"	—
s1(E)	57	#5	8'-0"	┌
s3(E)	83	#5	16'-7"	┌
s4(E)	8	#5	11'-4"	┌
s5(E)	16	#5	10'-11"	┌
s6(E)	8	#5	11'-5"	┌
s7(E)	24	#5	10'-4"	┌
s16(E)	18	#5	11'-6"	┌
sp3(E)	6	#5	20'-2"	⋈
u(E)	10	#6	12'-8"	┌
u2(E)	4	#5	10'-11"	┌
u3(E)	4	#5	13'-1"	┌
v3(E)	96	#9	24'-3"	┌
Concrete Structures			Cu. Yd.	130.6
Reinforcement Bars, Epoxy Coated			Pound	21,460
Concrete Sealer Protective Coat (Special)			Sq. Ft.	3,049
			Sq. Yd.	34

* Length is height of spiral.

MODEL: Default
FILE NAME: Z:\15052229_B&O_RR_Bridge\DCN\Bridg\final\Plotsheets\0820017-76K02-053-Substructure_Replacement_Pier 6 (EB).dgn

EFK Moen
Civil Engineering Design

USER NAME = khll	DESIGNED - ACB	REVISED -
PLOT SCALE = 0.1667"/in.	CHECKED - CDL	REVISED -
PLOT DATE = 8/13/2024	DRAWN - ACB	REVISED -
	CHECKED - CDL	REVISED -

**STATE OF ILLINOIS
DEPARTMENT OF TRANSPORTATION**

**SUBSTRUCTURE REPLACEMENT (PIER 6 EB)
STRUCTURE NO. 082-0017**

SHEET 53 OF 114 SHEETS

F.A.I. RTE.	SECTION	COUNTY	TOTAL SHEETS	SHEET NO.
55/70	82-5VB-R-2	ST. CLAIR	254	191
CONTRACT NO. 76K02				
ILLINOIS		FED. AID PROJECT		

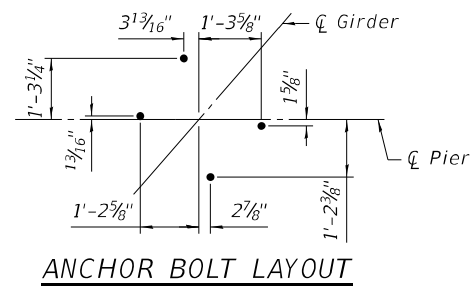

ANCHOR BOLT LAYOUT

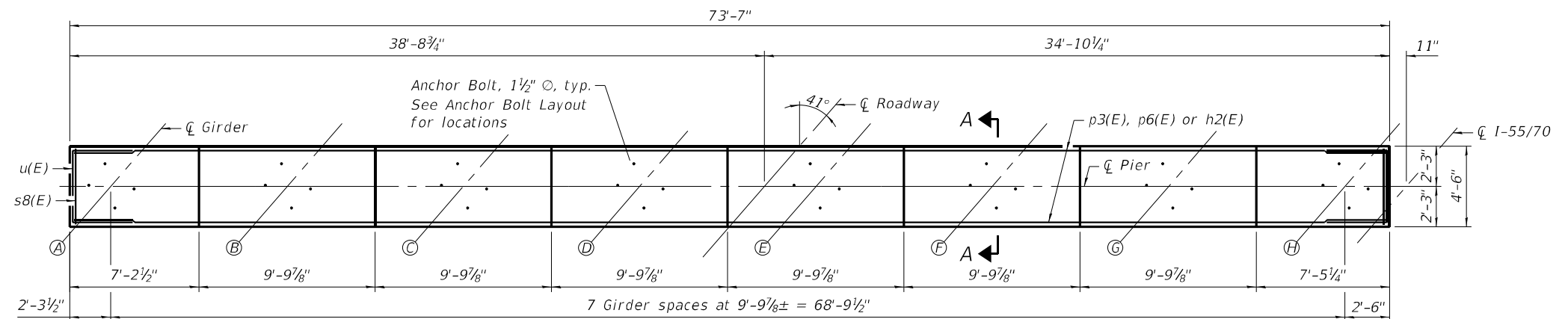

TOP PLAN

MINIMUM BAR LAP

- #5 bars = 2'-9"
- #6 bars = 3'-4"
- #8 bars = 5'-9"

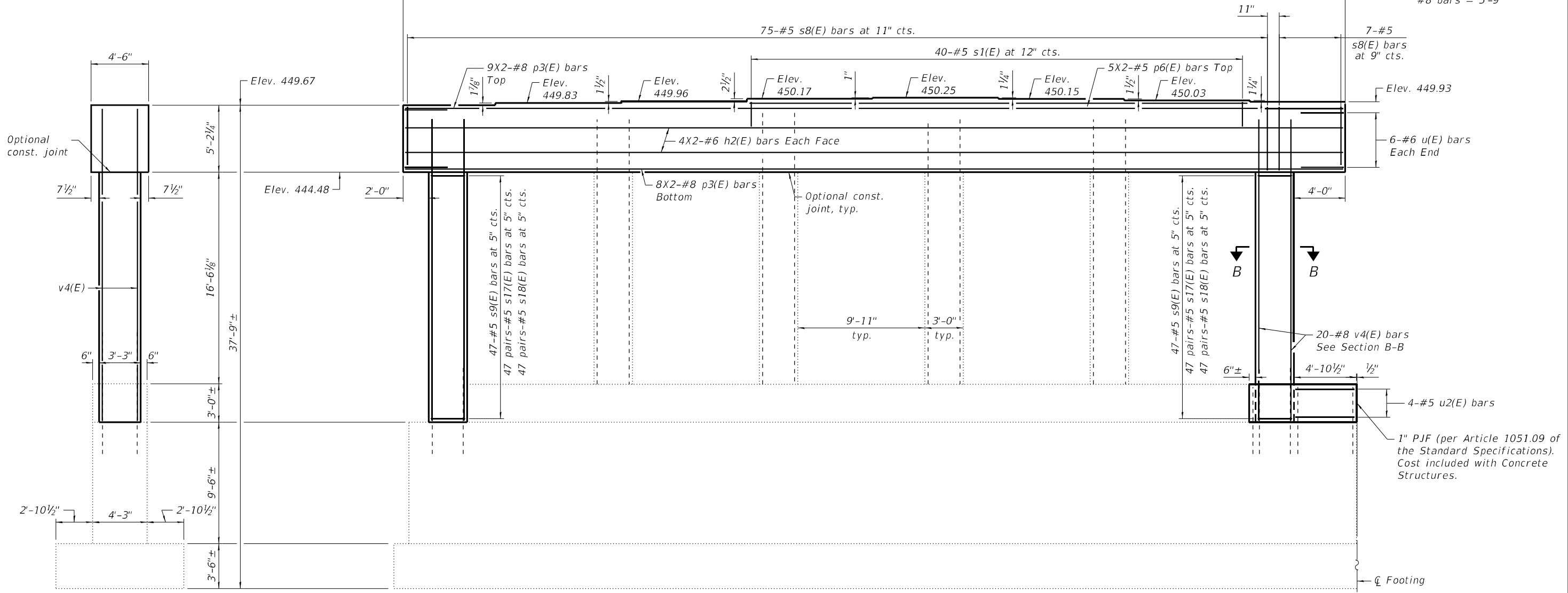

ELEVATION
(Looking North)

END VIEW
(Looking East)

Note:
Contractor shall adjust column height in field after verifying wall elevation. Column height can be adjusted up to 6" without notifying engineer of record. If required to meet minimums shown, reinforcement lengths shall be increased.
All exposed surfaces of new concrete for the pier cap, columns, and wall shall be treated with Concrete Sealer.
Bars indicated thus 1x4-#8 etc. indicates 1 line of bars with 4 lengths per line.

MODEL: Default
FILE NAME: Z:\15052,29_B&O RR Bridge\DCN\Bridg\final\Plotsheets\0820017-76K02-054-Substructure_Replacement_Pier 7 (WB).dgn



USER NAME = khill	DESIGNED - ACB	REVISED -
PLOT SCALE = 02'"/ft.	CHECKED - CDL	REVISED -
PLOT DATE = 8/13/2024	DRAWN - ACB	REVISED -
	CHECKED - CDL	REVISED -

STATE OF ILLINOIS
DEPARTMENT OF TRANSPORTATION

SUBSTRUCTURE REPLACEMENT (PIER 7 WB)
STRUCTURE NO. 082-0017

SHEET 54 OF 114 SHEETS

F.A.I. RTE.	SECTION	COUNTY	TOTAL SHEETS	SHEET NO.
55/70	82-5VB-R-2	ST. CLAIR	254	192
CONTRACT NO. 76K02				
ILLINOIS		FED. AID PROJECT		

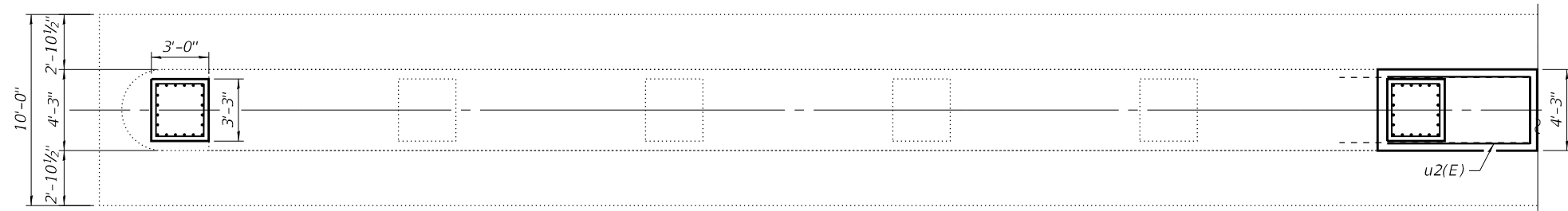

FOOTING PLAN

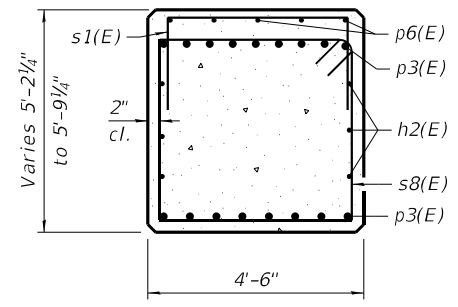

SECTION A-A

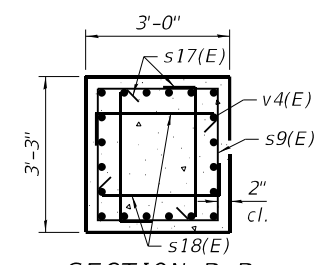

SECTION B-B

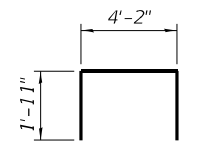

BAR s1(E)

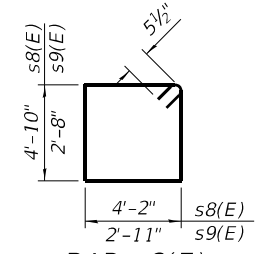

BAR s8(E) & s9(E)

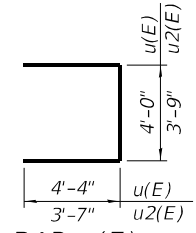

BAR u(E) & u2(E)

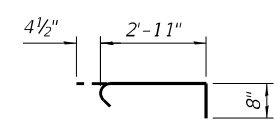

BAR s17(E)

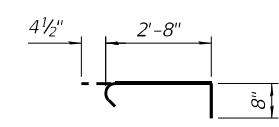

BAR s18(E)

BILL OF MATERIAL

Bar	No.	Size	Length	Shape
h2(E)	16	#6	38'-0"	—
p3(E)	34	#8	39'-6"	—
p6(E)	10	#5	25'-10"	—
s1(E)	40	#5	8'-0"	U
s8(E)	82	#5	18'-11"	□
s9(E)	94	#5	12'-1"	□
s17(E)	188	#5	4'-0"	U
s18(E)	188	#5	3'-9"	U
u(E)	12	#6	12'-8"	U
u2(E)	4	#5	10'-11"	U
v4(E)	40	#8	22'-10"	—
Concrete Structures			Cu. Yd.	84.8
Reinforcement Bars, Epoxy Coated			Pound	12,140
Concrete Sealer			Sq. Ft.	2,052

MODEL: Default
FILE NAME: Z:\15052229_B&O RR Bridge\DN\Bridg\final\Plotsheets\0820017-76K02-055-Substructure_Replacement_Pier 7 (WB).dgn
8/13/2024 9:41:53 AM

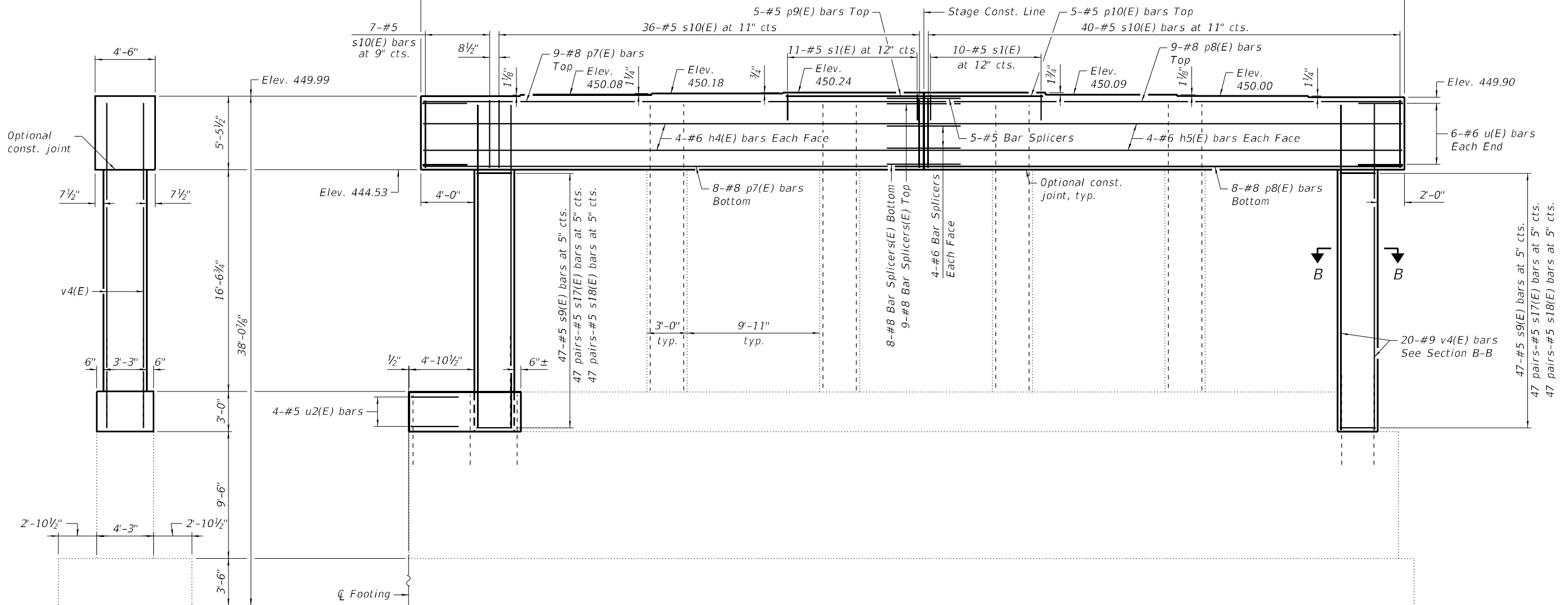
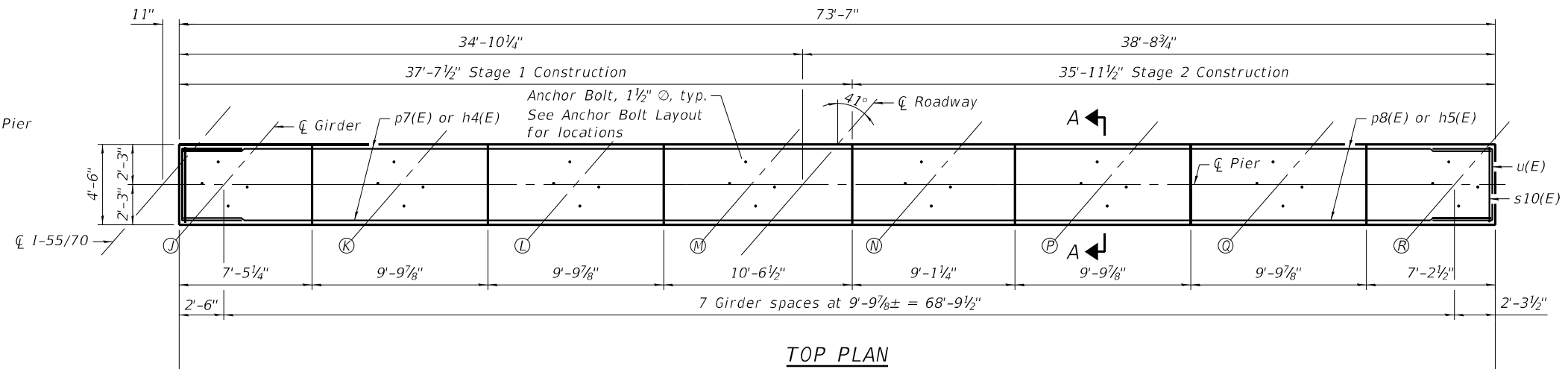
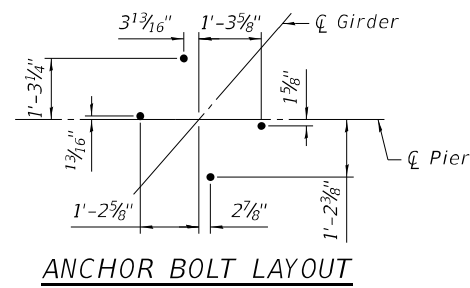

END VIEW
(Looking East)

ELEVATION
(Looking North)

Note: Stage construction shown for Eastbound replacement (with strongback system) per Sheets 97 thru 103 of 114. Refer to Sheet 85 of 114 for additional information.

Note:
Contractor shall adjust column height in field after verifying wall elevation. Column height can be adjusted up to 6" without notifying engineer of record. If required to meet minimums shown, reinforcement lengths shall be increased.
All exposed surfaces of new concrete for the pier cap, columns, and wall shall be treated with Concrete Sealer.

MODEL: Default
FILE NAME: Z:\1505229_B&O RR Bridge\DCN\Bridg\final\Plotsheets\082001776K02-056-Substructure_Replacement_Pier 7 (EB).dgn

EFK•Moen
Civil Engineering Design

USER NAME = khill	DESIGNED - ACB	REVISED -
PLOT SCALE = 02'"/ft.	CHECKED - CDL	REVISED -
PLOT DATE = 8/13/2024	DRAWN - ACB	REVISED -
	CHECKED - CDL	REVISED -

STATE OF ILLINOIS
DEPARTMENT OF TRANSPORTATION

SUBSTRUCTURE REPLACEMENT (PIER 7 EB)
STRUCTURE NO. 082-0017

SHEET 56 OF 114 SHEETS

F.A.I. RTE.	SECTION	COUNTY	TOTAL SHEETS	SHEET NO.
55/70	82-5VB-R-2	ST. CLAIR	254	194
CONTRACT NO. 76K02				

ILLINOIS FED. AID PROJECT

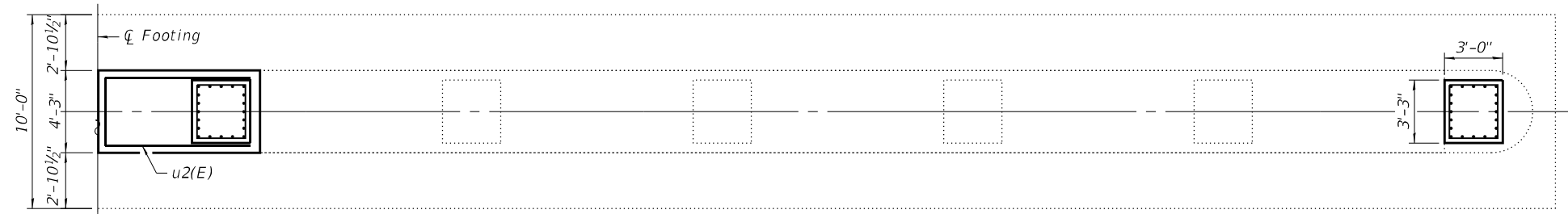

FOOTING PLAN

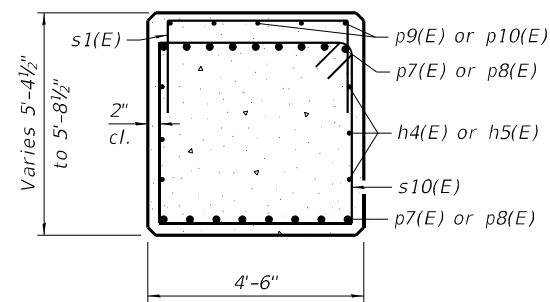

SECTION A-A

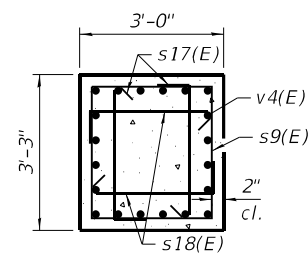

SECTION B-B

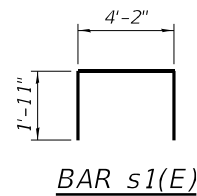

BAR s1(E)

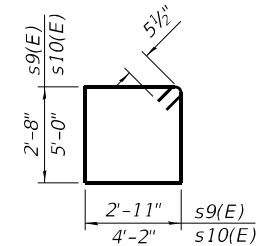

BAR s9(E)
& s10(E)

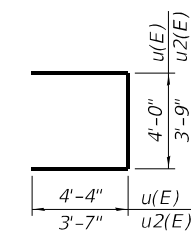

BAR u(E)
& u2(E)

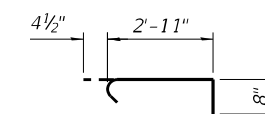

BAR s17(E)

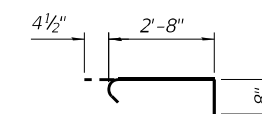

BAR s18(E)

BILL OF MATERIAL

Bar	No.	Size	Length	Shape
h4(E)	8	#6	37'-4"	—
h5(E)	8	#6	35'-8"	—
p7(E)	17	#8	37'-4"	—
p8(E)	17	#8	35'-8"	—
p9(E)	5	#5	10'-3"	—
p10(E)	5	#5	8'-10"	—
s1(E)	21	#5	8'-0"	U
s9(E)	94	#5	12'-1"	□
s10(E)	83	#5	19'-3"	□
s17(E)	188	#5	4'-0"	U
s18(E)	188	#5	3'-9"	U
u(E)	12	#6	12'-8"	U
u2(E)	4	#5	10'-11"	U
v4(E)	40	#8	22'-10"	—
Concrete Structures		Cu. Yd.	84.3	
Reinforcement Bars, Epoxy Coated		Pound	11,550	
Bar Splicers		Each	30	
Concrete Sealer		Sq. Ft.	1,971	

MODEL: Default
FILE NAME: Z:\1505229_B&O_RR_Bridge\GN\Bridg\final\Plotsheets\0820017-76K02-057-Substructure_Replacement_Pier 7 (EB).dgn
8/13/2024 9:41:55 AM

EFK Moen
Civil Engineering Design

USER NAME = khill	DESIGNED - ACB	REVISED -
PLOT SCALE = 0.1667' / in.	CHECKED - CDL	REVISED -
PLOT DATE = 8/13/2024	DRAWN - ACB	REVISED -
	CHECKED - CDL	REVISED -

STATE OF ILLINOIS
DEPARTMENT OF TRANSPORTATION

SUBSTRUCTURE REPLACEMENT (PIER 7 EB)
STRUCTURE NO. 082-0017

SHEET 57 OF 114 SHEETS

F.A.I. RTE.	SECTION	COUNTY	TOTAL SHEETS	SHEET NO.
55/70	82-5VB-R-2	ST. CLAIR	254	195
CONTRACT NO. 76K02				
ILLINOIS		FED. AID PROJECT		

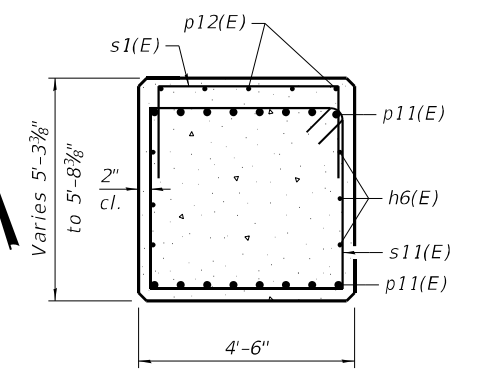
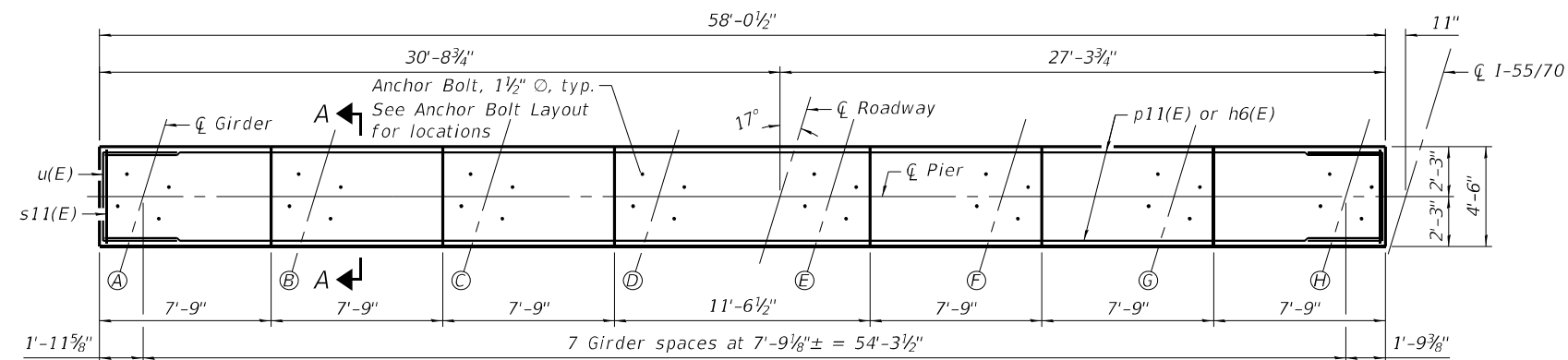
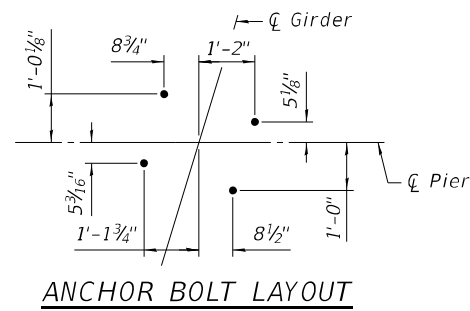

SECTION A-A

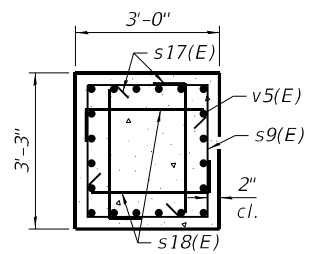

SECTION B-B

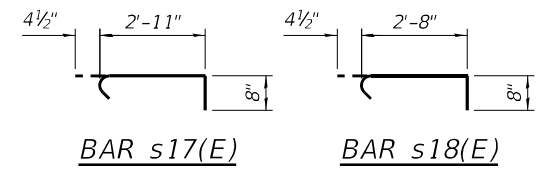

BAR s17(E)

BAR s18(E)

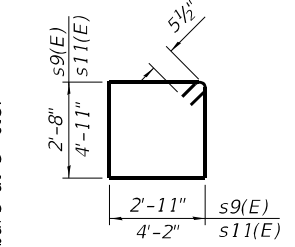

BAR s9(E) & s11(E)

BAR s1(E)

BILL OF MATERIAL

Bar	No.	Size	Length	Shape
h6(E)	16	#6	30'-3"	—
p11(E)	32	#8	31'-9"	—
p12(E)	5	#5	11'-3"	—
s1(E)	13	#5	8'-0"	□
s9(E)	98	#5	12'-1"	□
s11(E)	64	#5	19'-1"	□
s17(E)	196	#5	4'-0"	U
s18(E)	196	#5	3'-9"	U
u(E)	12	#6	12'-8"	—
v5(E)	40	#9	23'-9"	—
Concrete Structures			Cu. Yd.	67.7
Reinforcement Bars, Epoxy Coated			Pound	11,160
Concrete Sealer			Sq. Ft.	1,664

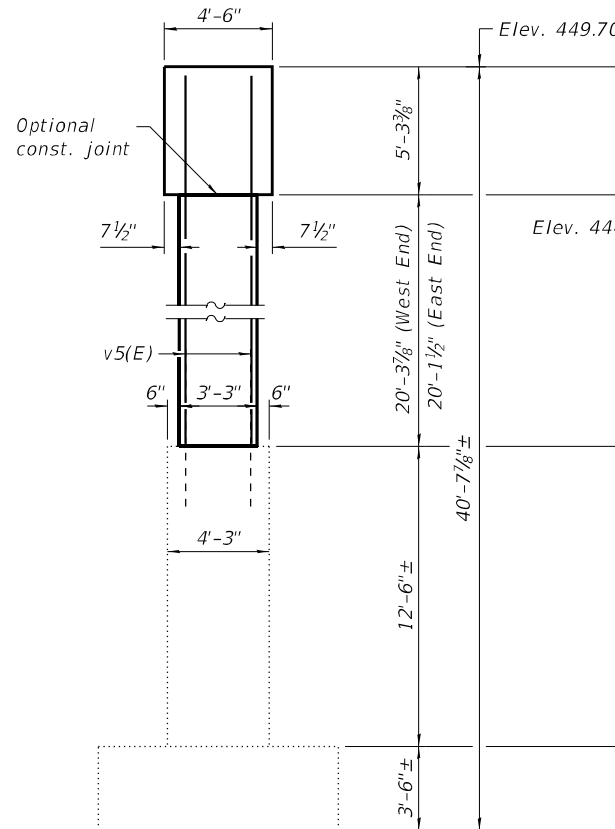

END VIEW (Looking East)

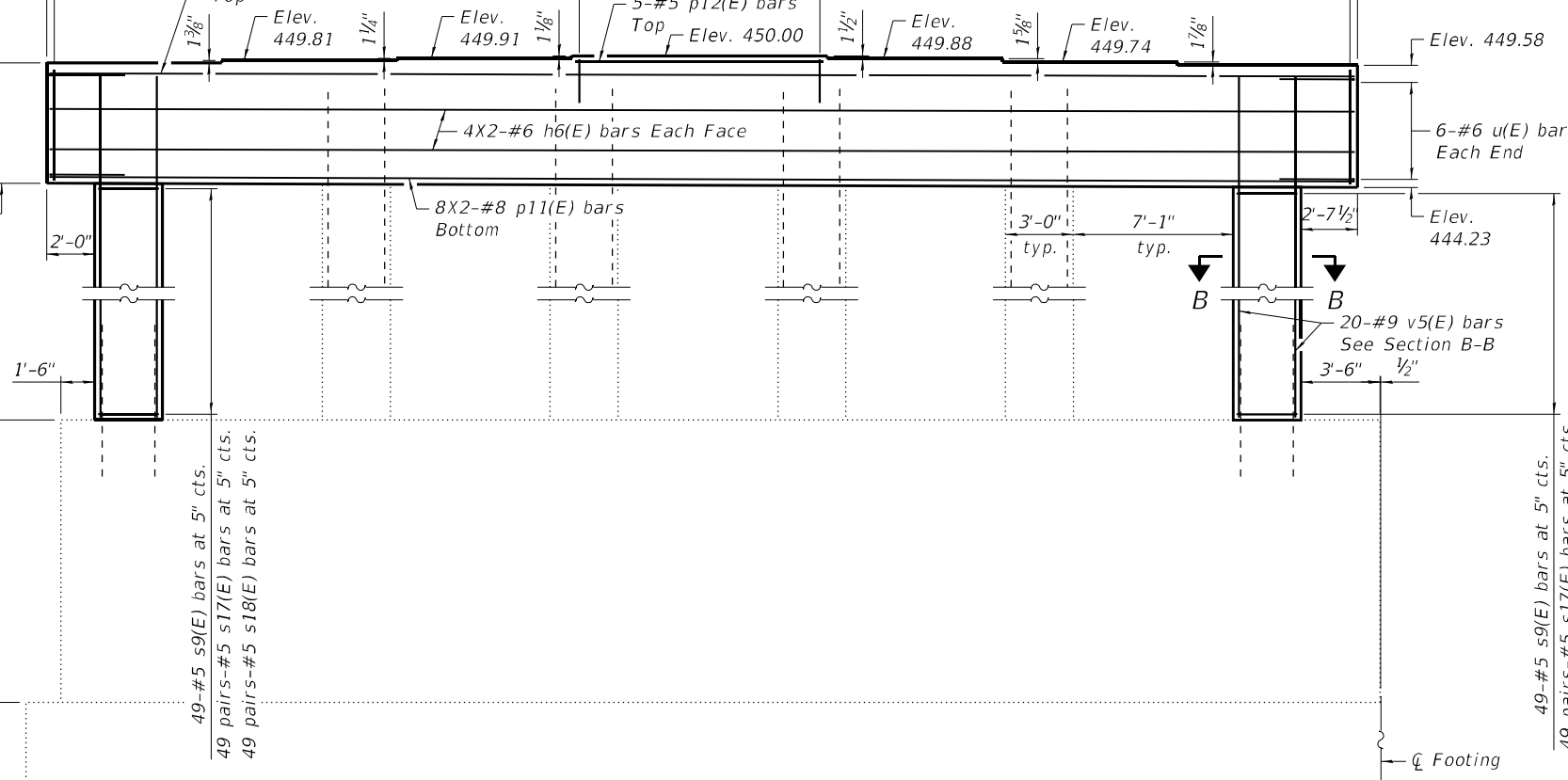

ELEVATION (Looking North)

MINIMUM BAR LAP

#6 bars = 3'-4"
#8 bars = 5'-9"

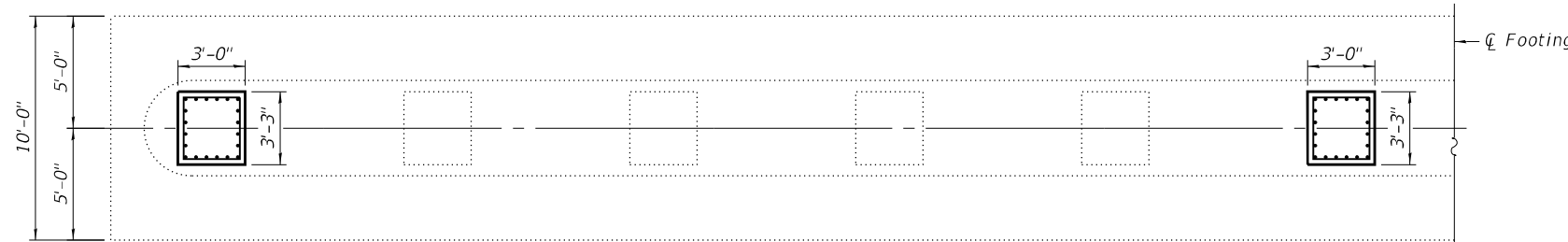

FOOTING PLAN

Note:
All exposed surfaces of new concrete for the pier cap and columns shall be treated with Concrete Sealer.
Bars indicated thus 1x4-#8 etc. indicates 1 line of bars with 4 lengths per line.

MODEL: Default
FILE NAME: Z:\1505229_B&O RR Bridge\DCN\Bridg\final\Plotsheets\0820017-76K02-05B-Substructure_Replacement_Pier 8 (WB).dgn

EFK Moen
Civil Engineering Design

USER NAME = khill
DESIGNED - ACB
CHECKED - CDL
PLOT SCALE = 0.1667"/in.
DRAWN - ACB
PLOT DATE = 8/13/2024
CHECKED - CDL
REVISED -

DESIGNED - ACB
CHECKED - CDL
DRAWN - ACB
PLOT DATE = 8/13/2024
CHECKED - CDL
REVISED -

DESIGNED - ACB
CHECKED - CDL
DRAWN - ACB
PLOT DATE = 8/13/2024
CHECKED - CDL
REVISED -

STATE OF ILLINOIS
DEPARTMENT OF TRANSPORTATION

SUBSTRUCTURE REPLACEMENT (PIER 8 WB)
STRUCTURE NO. 082-0017

SHEET 58 OF 114 SHEETS

F.A.I. RTE. SECTION COUNTY TOTAL SHEETS SHEET NO.
5570 82-5VB-R-2 ST. CLAIR 254 196
CONTRACT NO. 76K02
ILLINOIS FED. AID PROJECT

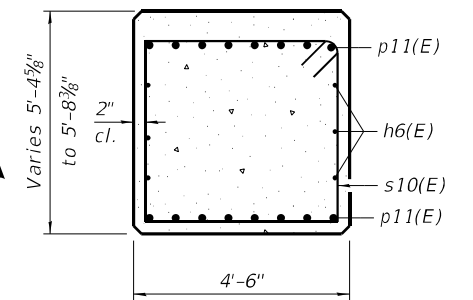
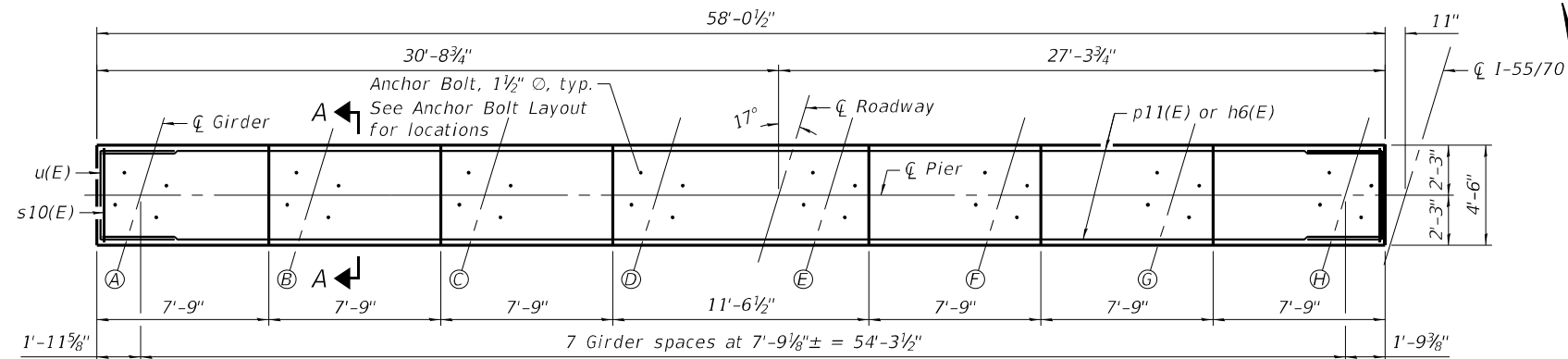
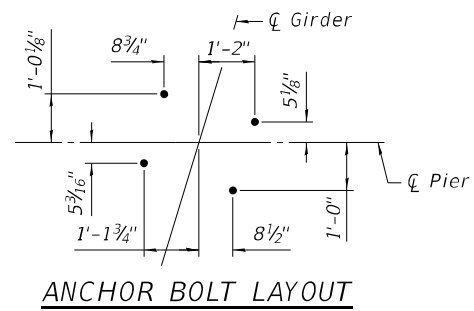

SECTION A-A

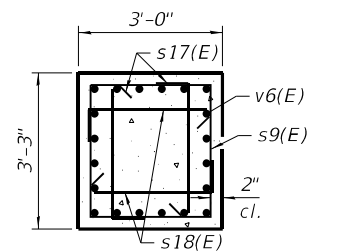

SECTION B-B

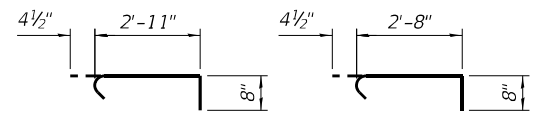

BAR s17(E)

BAR s18(E)

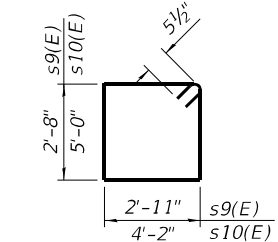

BAR s9(E)
& s10(E)

BILL OF MATERIAL

Bar	No.	Size	Length	Shape
h6(E)	16	#6	30'-3"	—
p11(E)	32	#8	31'-9"	—
s9(E)	92	#5	12'-1"	□
s10(E)	64	#5	19'-3"	□
s17(E)	184	#5	4'-0"	U
s18(E)	184	#5	3'-9"	U
u(E)	12	#6	12'-8"	—
v6(E)	40	#9	22'-0"	—
Concrete Structures			Cu. Yd.	67.4
Reinforcement Bars, Epoxy Coated			Pound	10,590
Concrete Sealer			Sq. Ft.	1,639

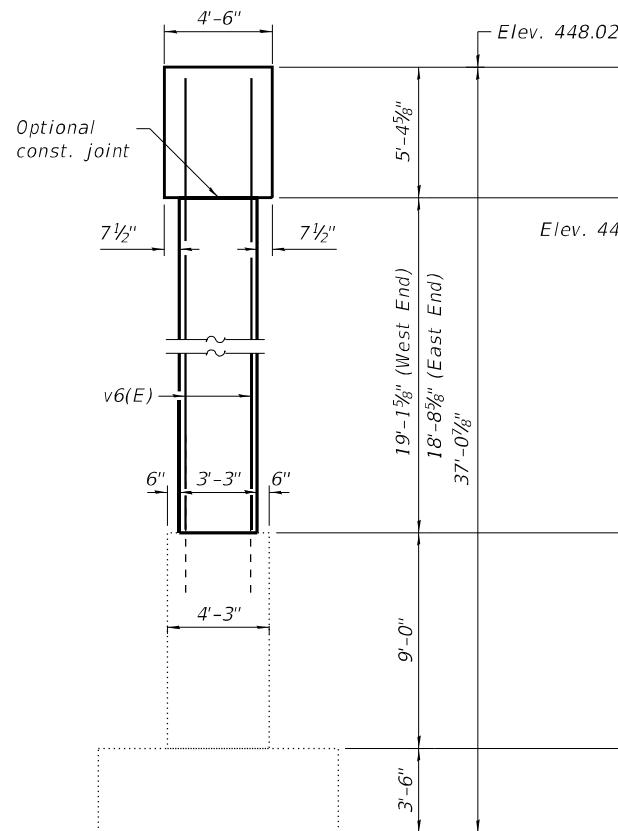

END VIEW
(Looking East)

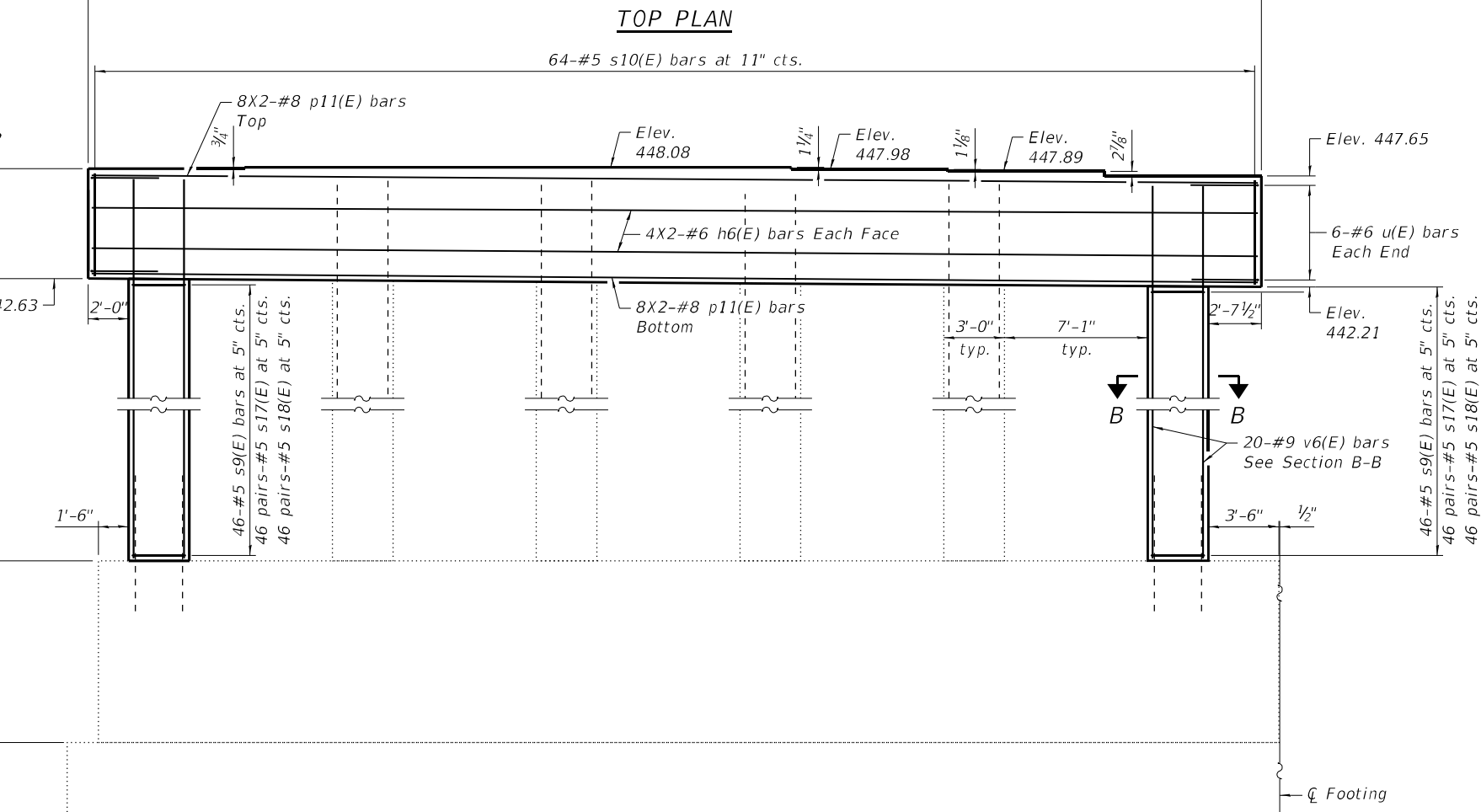

ELEVATION
(Looking North)

MINIMUM BAR LAP
#6 bars = 3'-4"
#8 bars = 5'-9"

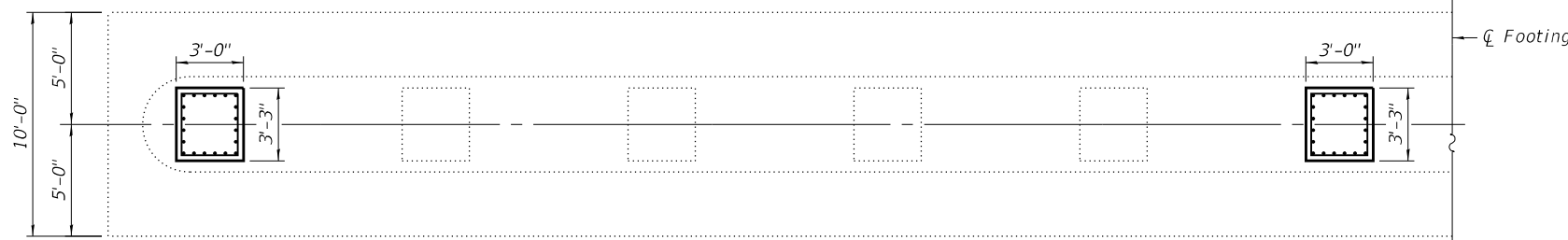

FOOTING PLAN

Note:
All exposed surfaces of new concrete for the pier cap and columns shall be treated with Concrete Sealer.
Bars indicated thus 1x4-#8 etc. indicates 1 line of bars with 4 lengths per line.

MODEL: Default
FILE NAME: Z:\1505229_B&O RR Bridge\DCN\Bridg\final\Plotsheets\0820017-76K02-060-Substructure Replacement Pier 9 (WB).dgn
8/13/2024 9:41:57 AM

EFK Moen
Civil Engineering Design

USER NAME = khll	DESIGNED - ACB	REVISED -
PLOT SCALE = 02" = 1'-0"	CHECKED - CDL	REVISED -
PLOT DATE = 8/13/2024	DRAWN - ACB	REVISED -
	CHECKED - CDL	REVISED -

STATE OF ILLINOIS
DEPARTMENT OF TRANSPORTATION

SUBSTRUCTURE REPLACEMENT (PIER 9 WB)
STRUCTURE NO. 082-0017

SHEET 60 OF 114 SHEETS

F.A.I. RTE.	SECTION	COUNTY	TOTAL SHEETS	SHEET NO.
5570	82-5VB-R-2	ST. CLAIR	254	198
CONTRACT NO. 76K02				
ILLINOIS FED. AID PROJECT				

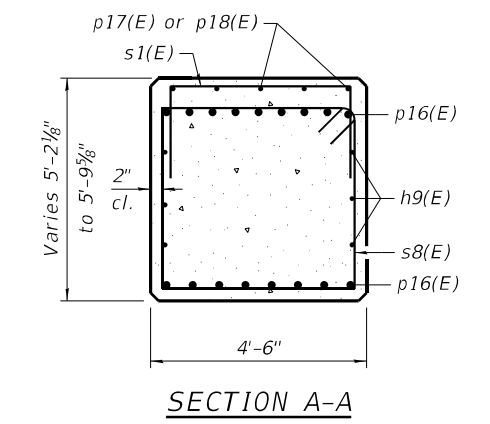
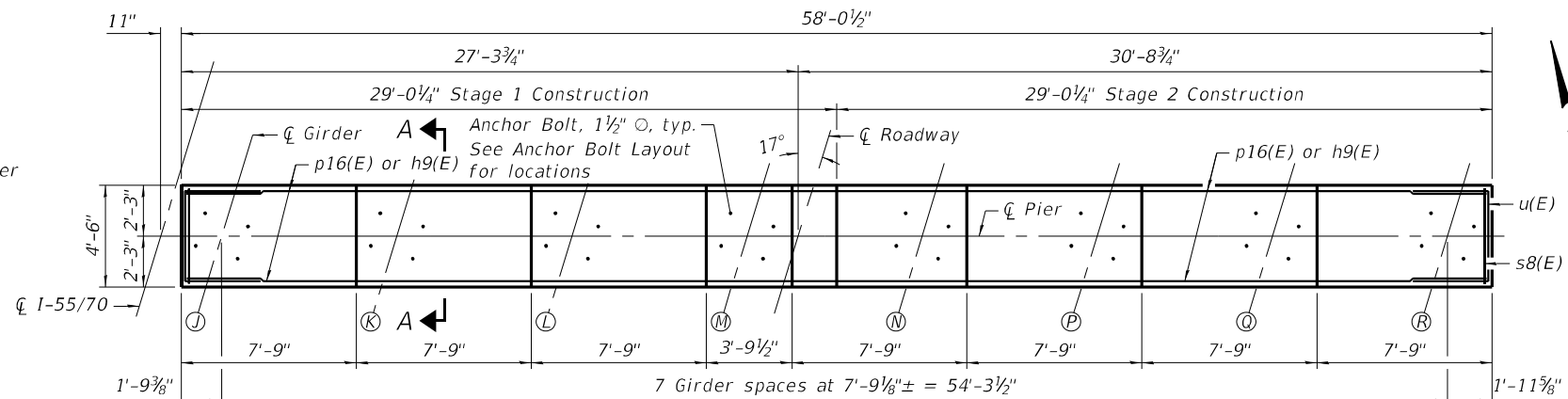
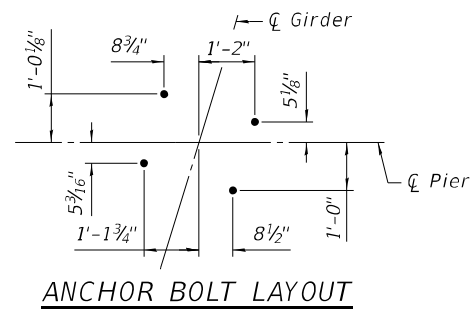

Note: Refer to Sheet 85 of 114 for additional information regarding staged construction.

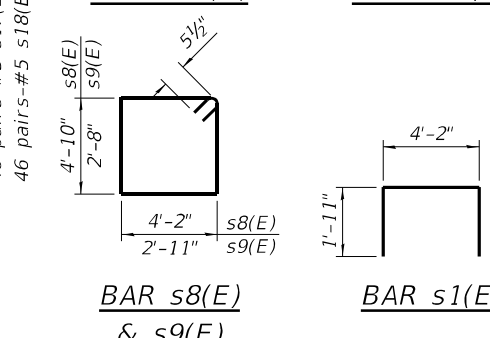
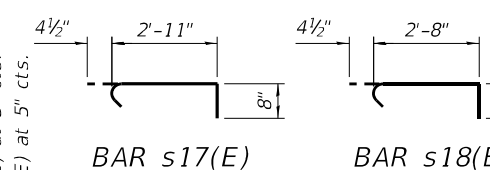
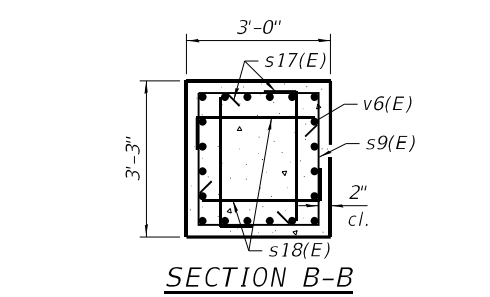

BILL OF MATERIAL

Bar	No.	Size	Length	Shape
h9(E)	16	#6	28'-10"	—
p16(E)	32	#8	28'-10"	—
p17(E)	5	#5	13'-4"	—
p18(E)	5	#5	5'-7"	—
s1(E)	20	#5	8'-0"	□
s8(E)	64	#5	18'-11"	□
s9(E)	92	#5	12'-1"	□
s17(E)	184	#5	4'-0"	U
s18(E)	184	#5	3'-9"	U
u(E)	12	#6	12'-8"	—
v6(E)	40	#9	22'-0"	—
Concrete Structures		Cu. Yd.	67.2	
Reinforcement Bars, Epoxy Coated		Pound	10,550	
Concrete Sealer		Sq. Ft.	1,632	
Bar Splicers		Each	30	

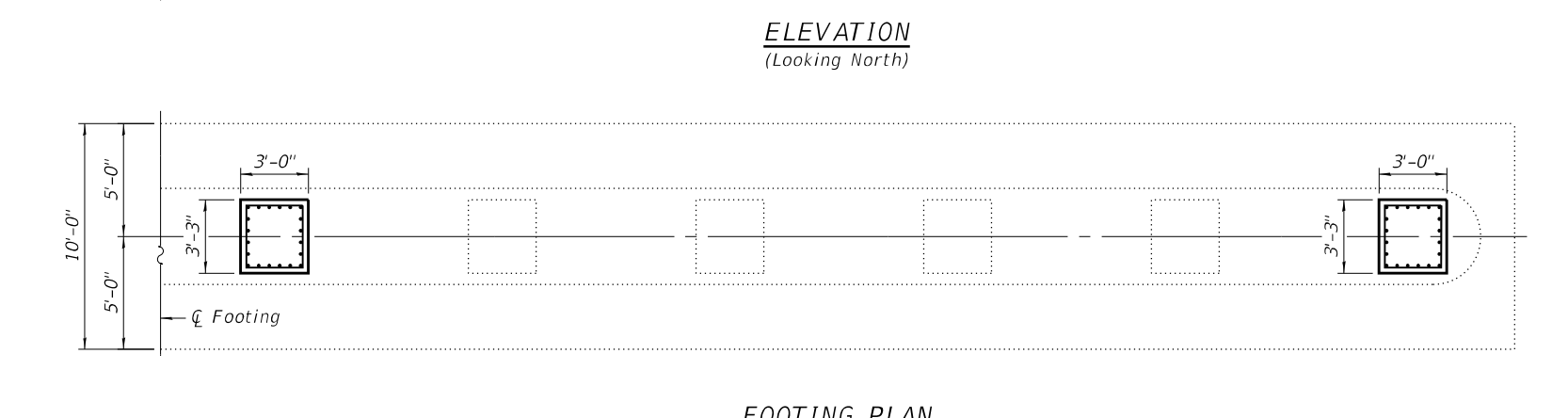
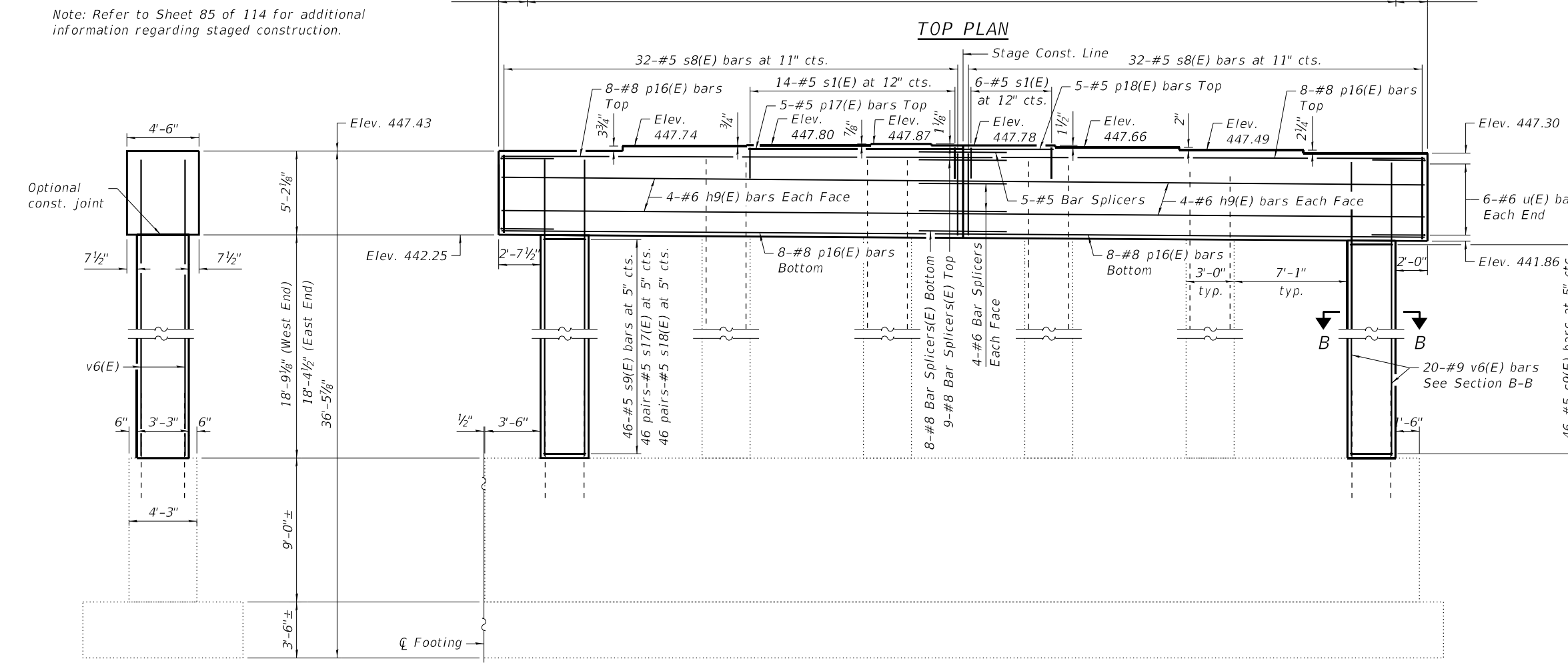

MINIMUM BAR LAP
#6 bars = 3'-4"
#8 bars = 5'-9"

Note:
All exposed surfaces of new concrete for the pier cap and columns shall be treated with Concrete Sealer.
Bars indicated thus 1x4-#8 etc. indicates 1 line of bars with 4 lengths per line.

MODEL: Default
FILE NAME: Z:\1505229_B&O RR Bridge\DNV\Bridge\final\Plotsheets\0820017-76K02-061-Substructure_Replacement_Pier 9 (EB).dgn
8/13/2024 9:41:58 AM

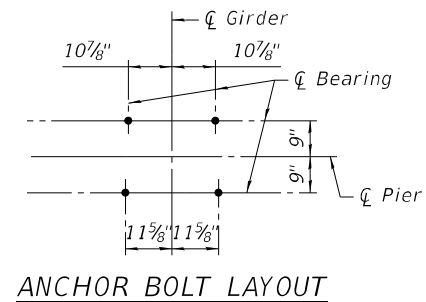

ANCHOR BOLT LAYOUT

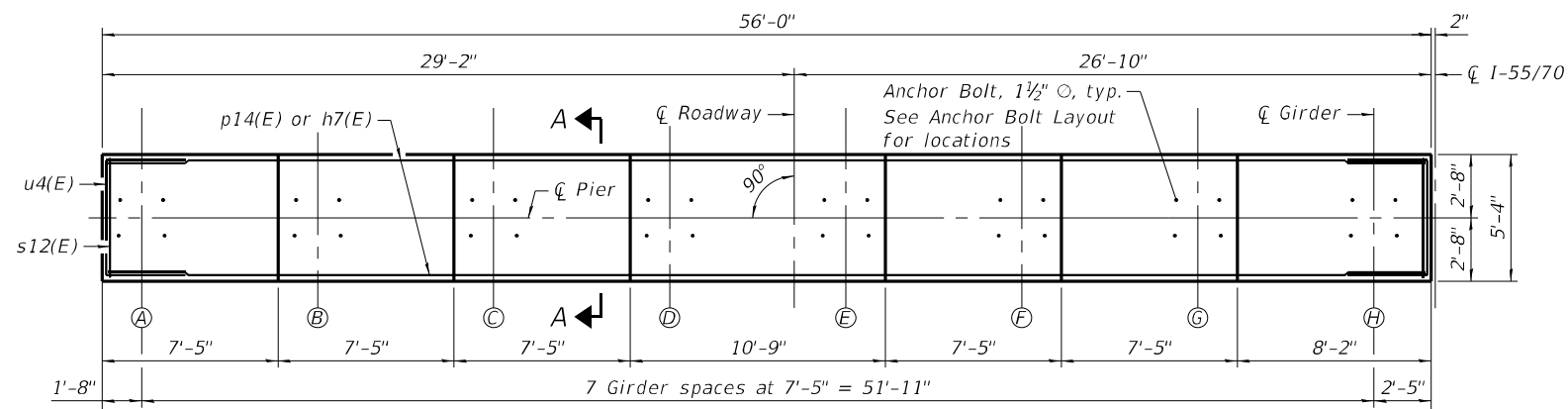

TOP PLAN

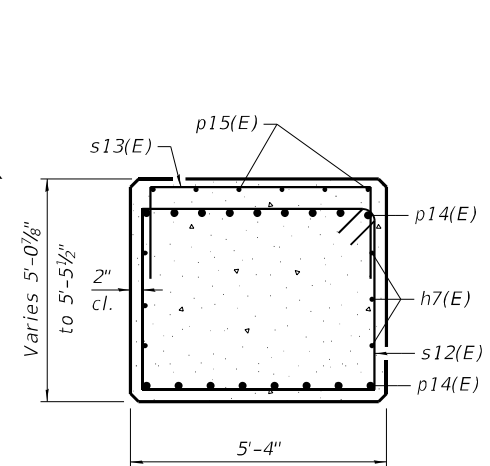

SECTION A-A

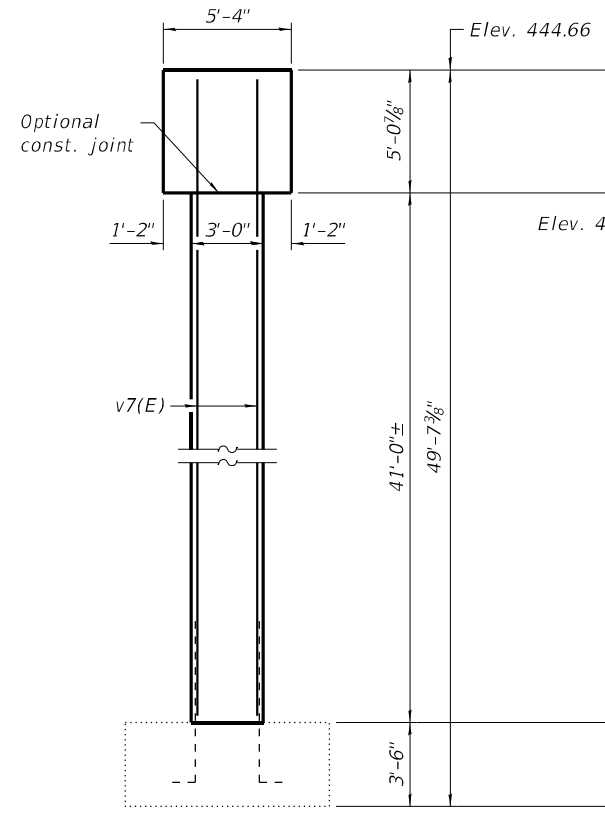

END VIEW (Looking East)

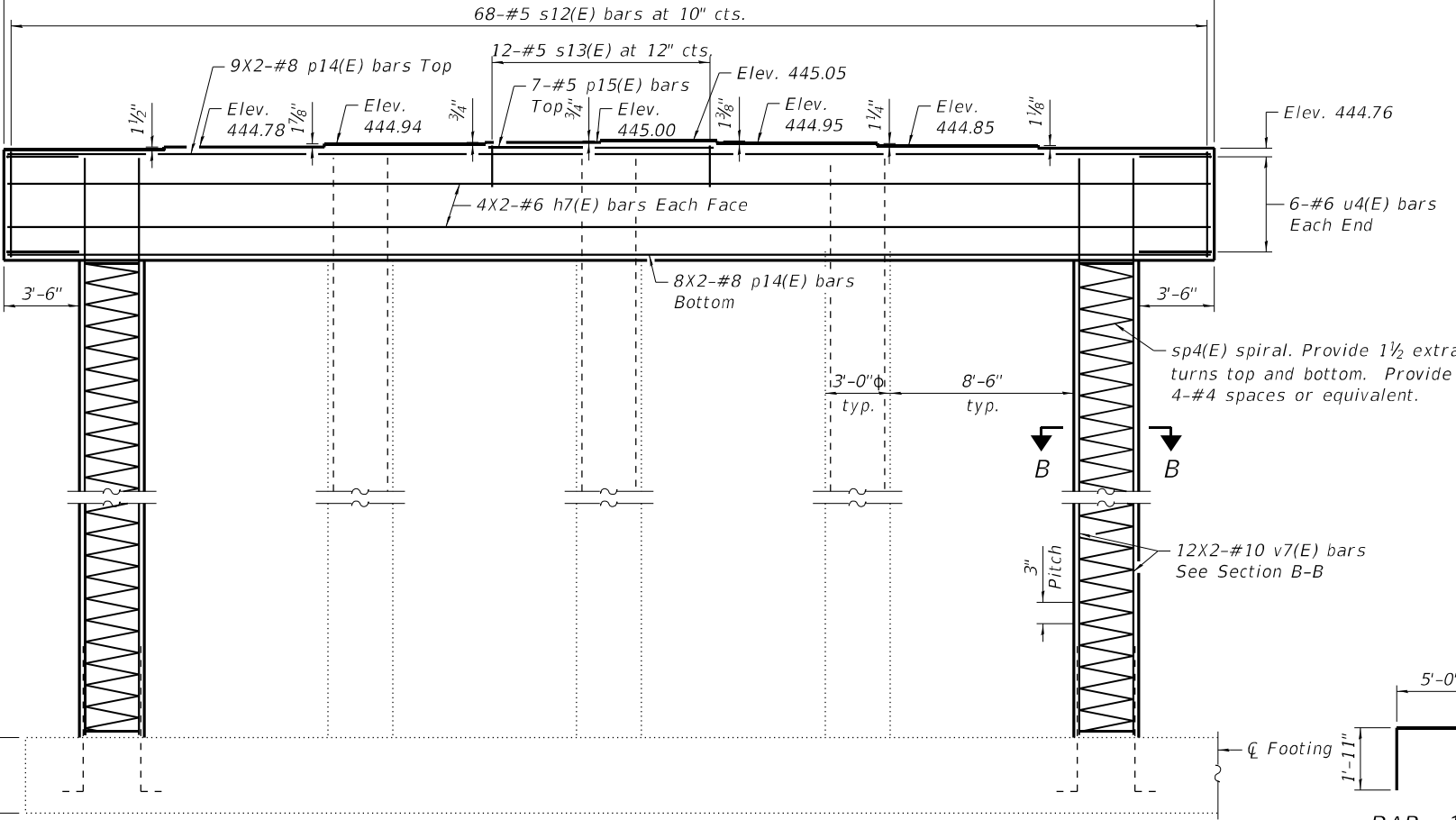

ELEVATION (Looking North)

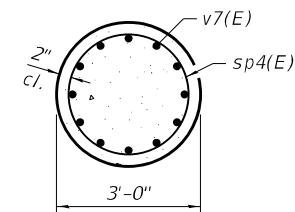

SECTION B-B

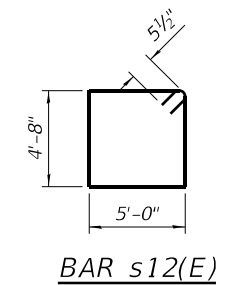

BAR s12(E)

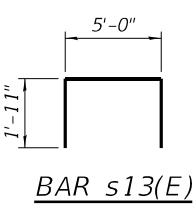

BAR s13(E)

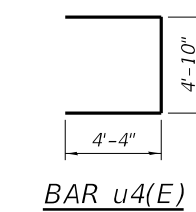

BAR u4(E)

MINIMUM BAR LAP

- #6 bars = 3'-4"
- #8 bars = 5'-9"
- #10 bars = 6'-9"

Note: All exposed surfaces of new concrete for the pier cap and columns shall be treated with Concrete Sealer. Bars indicated thus 1x4-#8 etc. indicates 1 line of bars with 4 lengths per line.

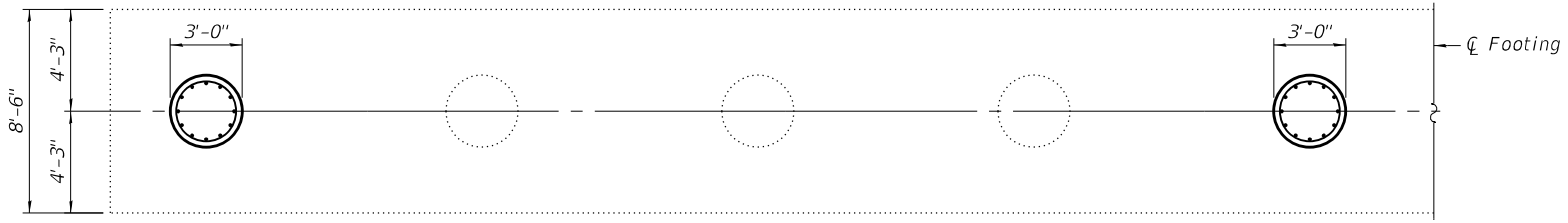

FOOTING PLAN

BILL OF MATERIAL

Bar	No.	Size	Length	Shape
h7(E)	16	#6	29'-3"	—
p14(E)	34	#8	30'-9"	—
p15(E)	7	#5	10'-5"	—
s12(E)	68	#5	20'-3"	□
s13(E)	12	#5	8'-10"	□
sp4(E)	2	#4	40'-9"	⋈
u4(E)	12	#6	13'-6"	—
v7(E)	48	#10	25'-9"	—
Concrete Structures		Cu. Yd.	112.0	
Reinforcement Bars, Epoxy Coated		Pound	12,510	
Concrete Sealer		Sq. Ft.	3,148	

* Length is height of spiral.

MODEL: Default
FILE NAME: Z:\1505229_B&O RR Bridge\DCN\Bridg\final\Plotsheets\082001776K02-062-Substructure_Replacement_Pier 10 (WB).dgn
8/13/2024 9:41:59 AM

EFK Moen
Civil Engineering Design

USER NAME = khill	DESIGNED - ACB	REVISED -
PLOT SCALE = 02" = 1'-0"	CHECKED - CDL	REVISED -
PLOT DATE = 8/13/2024	DRAWN - ACB	REVISED -
	CHECKED - CDL	REVISED -

STATE OF ILLINOIS
DEPARTMENT OF TRANSPORTATION

SUBSTRUCTURE REPLACEMENT (PIER 10 WB)
STRUCTURE NO. 082-0017

SHEET 62 OF 114 SHEETS

F.A.I. RTE.	SECTION	COUNTY	TOTAL SHEETS	SHEET NO.
55/70	82-5VB-R-2	ST. CLAIR	254	200
CONTRACT NO. 76K02				
ILLINOIS FED. AID PROJECT				

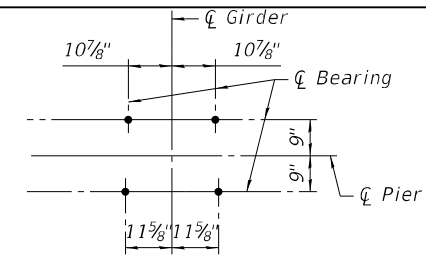

ANCHOR BOLT LAYOUT
Beams J-K

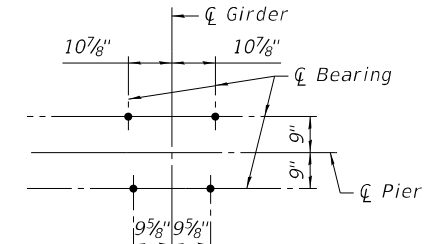

ANCHOR BOLT LAYOUT
Beams L-R

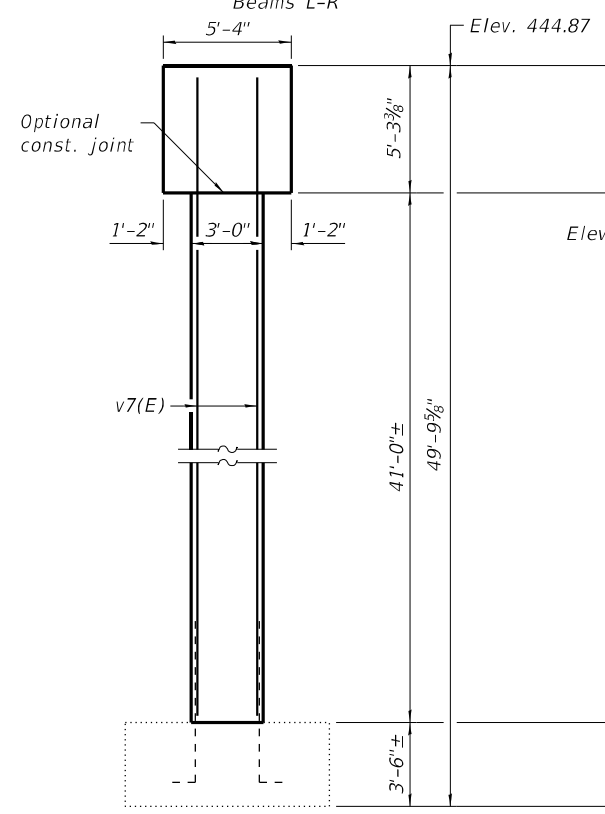

END VIEW
(Looking East)

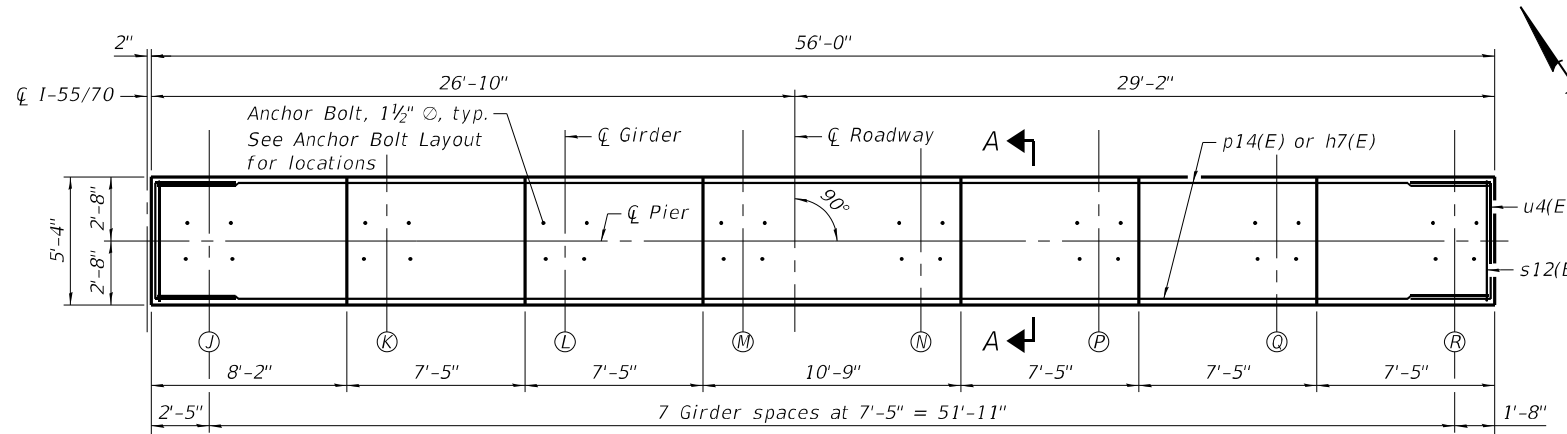

TOP PLAN

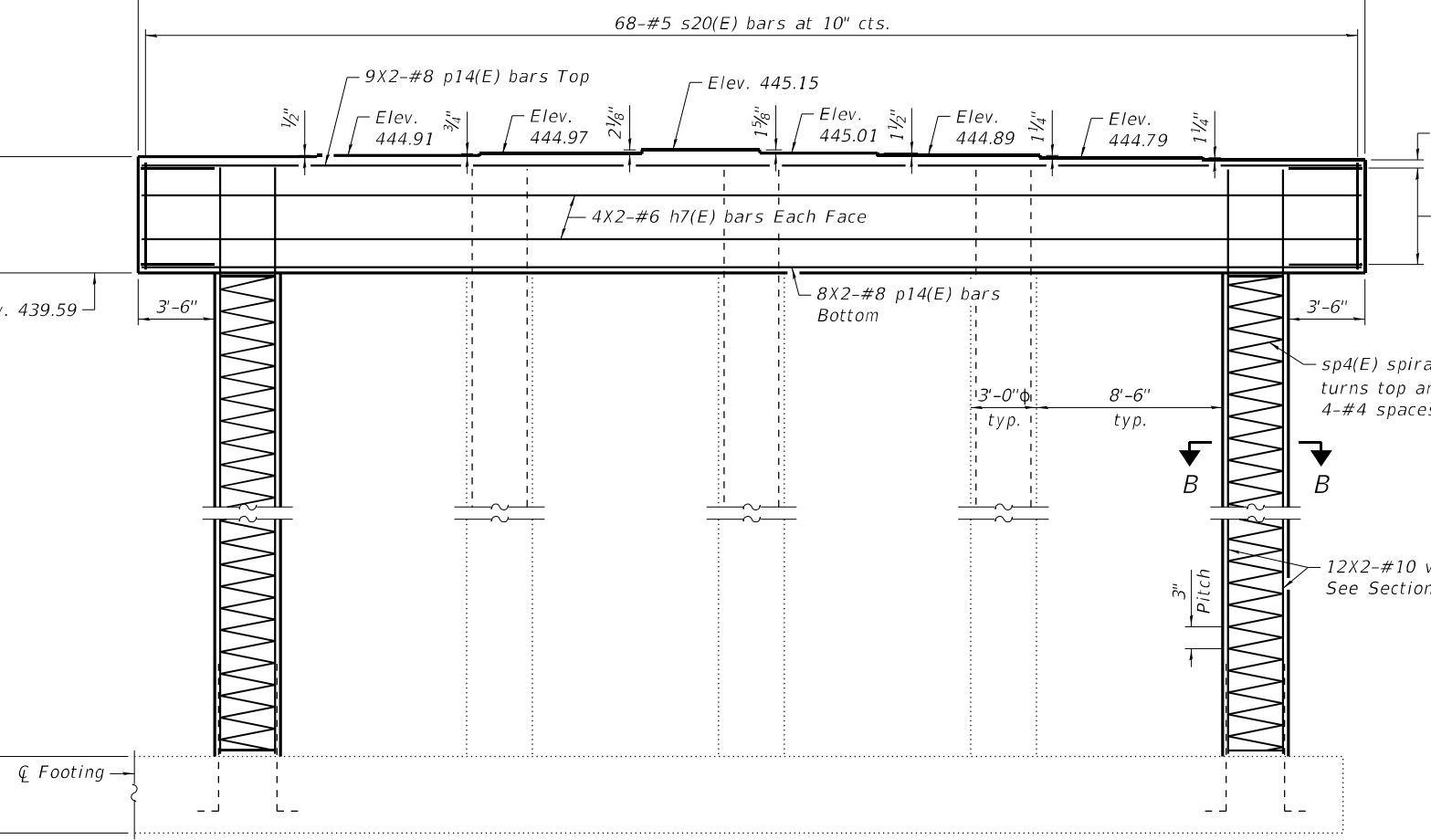

ELEVATION
(Looking North)

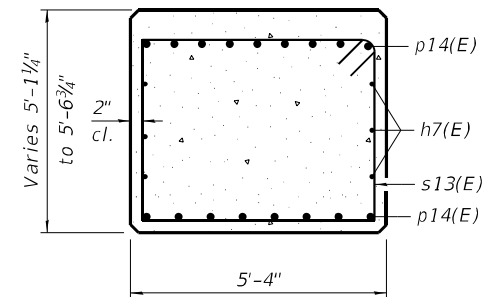

SECTION A-A

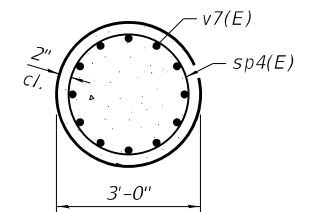

SECTION B-B

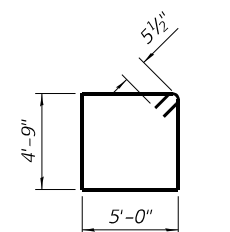

BAR s20(E)

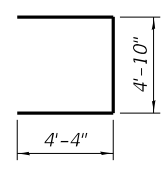

BAR u4(E)

MINIMUM BAR LAP

- #6 bars = 3'-4"
- #8 bars = 5'-9"
- #10 bars = 6'-9"

Note:
All exposed surfaces of new concrete for the pier cap and columns shall be treated with Concrete Sealer.
Bars indicated thus 1x4-#8 etc. indicates 1 line of bars with 4 lengths per line.

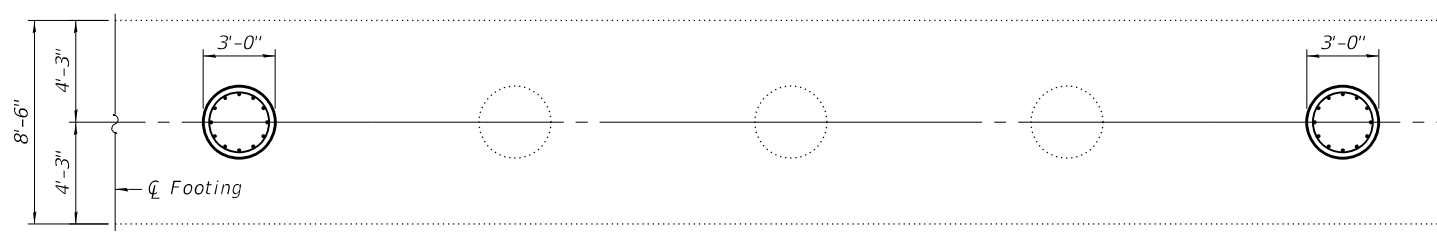

FOOTING PLAN

BILL OF MATERIAL

Bar	No.	Size	Length	Shape
h7(E)	16	#6	29'-3"	—
p14(E)	34	#8	30'-9"	—
s20(E)	68	#5	20'-9"	□
sp4(E)	2	#4	40'-9"	⋈
u4(E)	12	#6	13'-6"	▭
v7(E)	48	#10	25'-9"	—
Concrete Structures		Cu. Yd.	112.4	
Reinforcement Bars, Epoxy Coated		Pound	12,330	
Concrete Sealer		Sq. Ft.	3,153	

* Length is height of spiral.

MODEL: Default
FILE NAME: Z:\15052229_B&O RR Bridge\DCN\Bridg\final\Plotsheets\082001776K02-063-Substructure_Replacement_Pier 10 (EB).dgn
8/13/2024 9:42:00 AM

EFK Moen
Civil Engineering Design

USER NAME = khill	DESIGNED - ACB	REVISED -
PLOT SCALE = 0.1667'/in.	CHECKED - CDL	REVISED -
PLOT DATE = 8/13/2024	DRAWN - ACB	REVISED -
	CHECKED - CDL	REVISED -

STATE OF ILLINOIS
DEPARTMENT OF TRANSPORTATION

SUBSTRUCTURE REPLACEMENT (PIER 10 EB)
STRUCTURE NO. 082-0017

SHEET 63 OF 114 SHEETS

F.A.I. RTE.	SECTION	COUNTY	TOTAL SHEETS	SHEET NO.
55/70	82-5VB-R-2	ST. CLAIR	254	201
CONTRACT NO. 76K02				
ILLINOIS		FED. AID PROJECT		

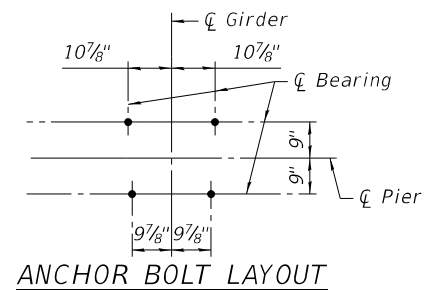

MINIMUM BAR LAP
 #6 bars = 3'-4"
 #8 bars = 5'-9"

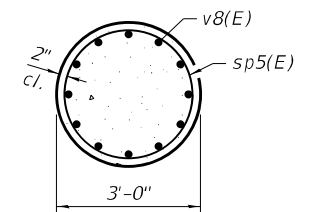
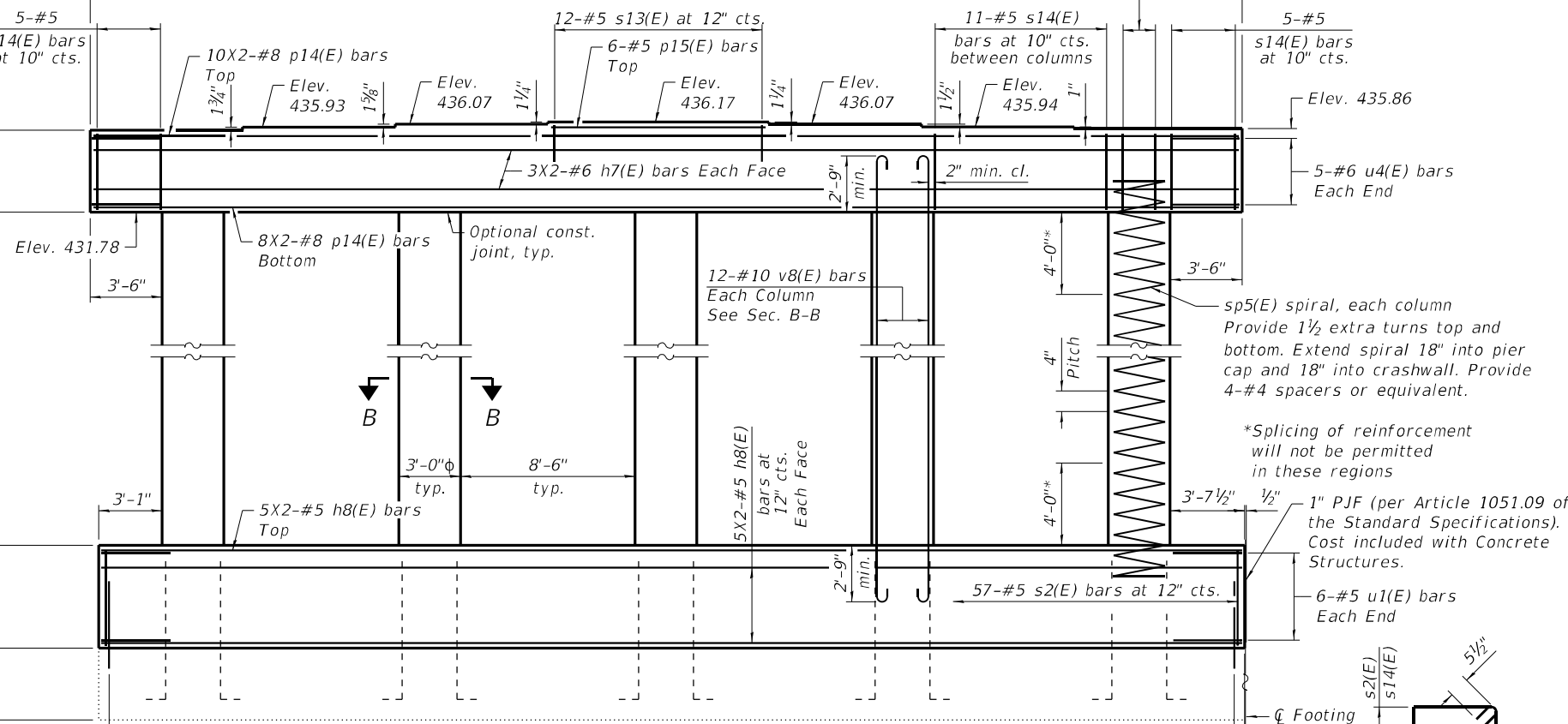
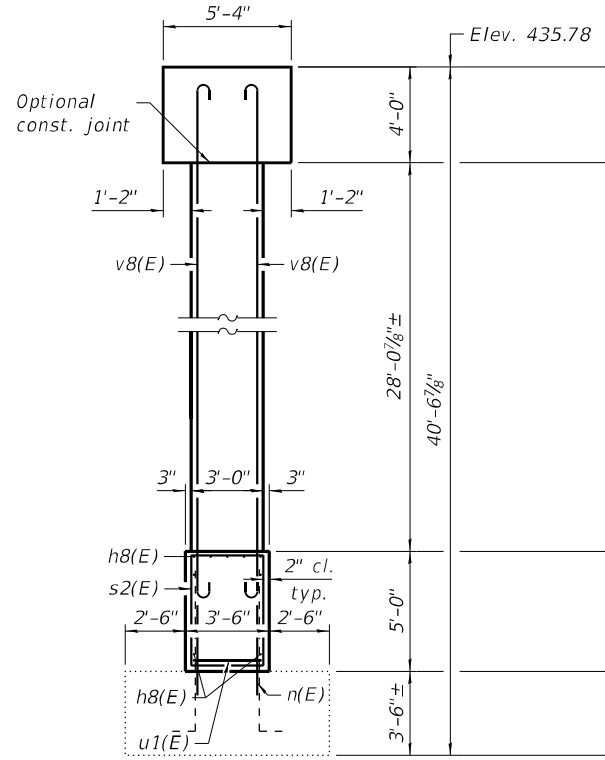
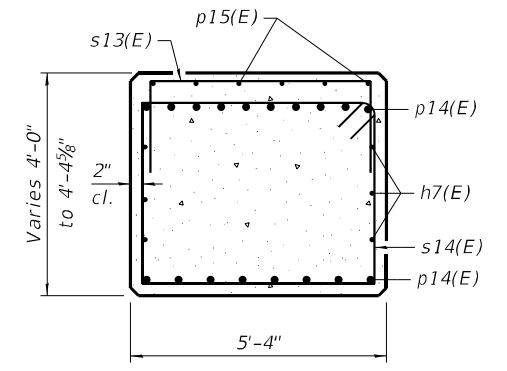
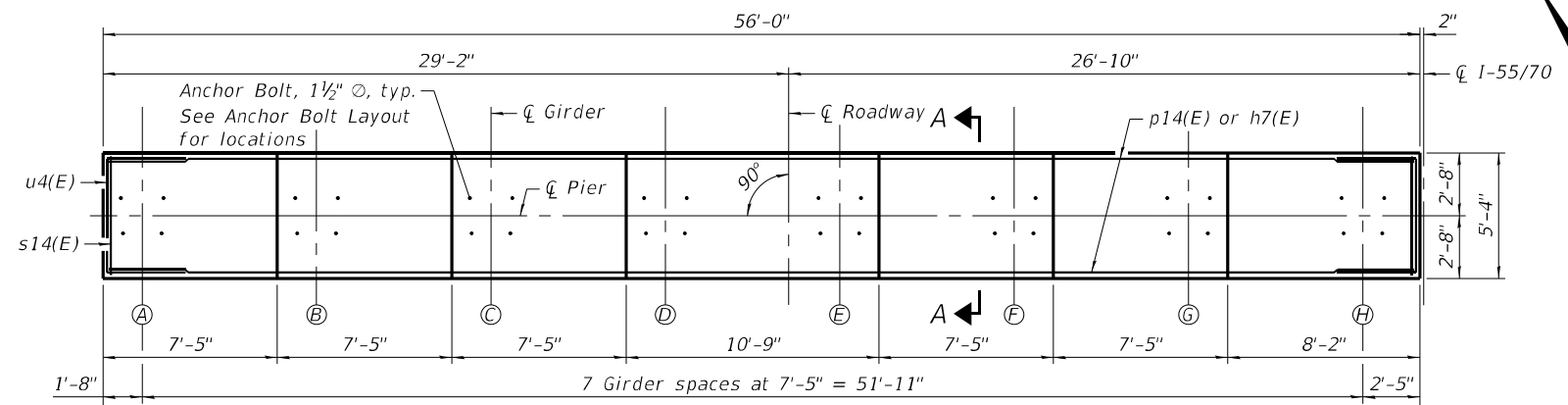

Note:
 Contractor shall adjust column heights in field after verifying footing elevation. Column heights can be adjusted up to 6" without notifying Engineer. If required to meet minimums shown, reinforcement lengths shall be increased.
 All exposed surfaces of new concrete for the pier cap, columns, and wall shall be treated with Concrete Sealer.
 Bars indicatd thus 1x4-#8 etc. indicatse 1 line of bars with 4 length per line.

BILL OF MATERIAL

Bar	No.	Size	Length	Shape
h7(E)	12	#6	29'-3"	—
h8(E)	30	#5	29'-1"	—
n(E)	114	#5	4'-3"	—
p14(E)	36	#8	30'-9"	—
p15(E)	6	#5	10'-5"	—
s2(E)	57	#5	16'-7"	□
s13(E)	12	#5	8'-10"	U
s14(E)	54	#5	18'-3"	□
s19(E)	15	#5	12'-4"	U
sp5(E)	5	#5	31'-1"	⋈
u1(E)	12	#5	10'-2"	—
u4(E)	10	#6	13'-6"	—
v8(E)	60	#10	36'-6"	—
Concrete Structures		Cu. Yd.	119.4	
Reinforcement Bars, Epoxy Coated		Pound	21,160	
Concrete Sealer		Sq. Ft.	2,403	

*** Length is height of spiral.

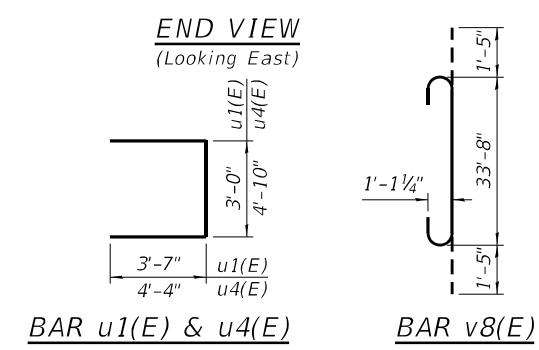

**Epoxy grout n(E) bars according to Section 584 of the Standard Specifications. Minimum embedment is 12". Embedment depth may be reduced according to the epoxy Manufacturer, if the Contractor provides the Engineer in writing that the shallower embedment depth is capable of developing the full yield strength of the reinforcement at the surface of the existing concrete.

MODEL: Default
 FILE NAME: Z:\15052229 BRIDGE\DNV\Bridge\final\Plotsheets\082001776K02-064-Substructure- Replacement Pier 13 (WB).dgn
 8/13/2024 9:42:01 AM

EFK Moen
 Civil Engineering Design

USER NAME = khll	DESIGNED - ACB	REVISED -
PLOT SCALE = 0.1667'/in.	CHECKED - CDL	REVISED -
PLOT DATE = 8/13/2024	DRAWN - ACB	REVISED -
	CHECKED - CDL	REVISED -

STATE OF ILLINOIS
 DEPARTMENT OF TRANSPORTATION

SUBSTRUCTURE REPLACEMENT (PIER 13 WB)
 STRUCTURE NO. 082-0017

SHEET 64 OF 114 SHEETS

F.A.I. RTE.	SECTION	COUNTY	TOTAL SHEETS	SHEET NO.
55/70	82-5VB-R-2	ST. CLAIR	254	202
CONTRACT NO. 76K02				
ILLINOIS FED. AID PROJECT				

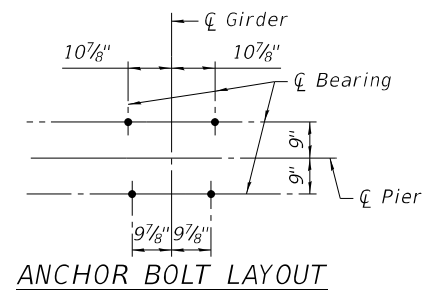

MINIMUM BAR LAP
 #6 bars = 3'-4"
 #8 bars = 5'-9"

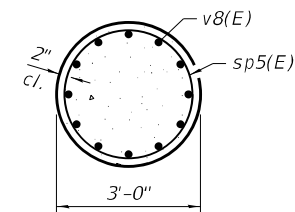
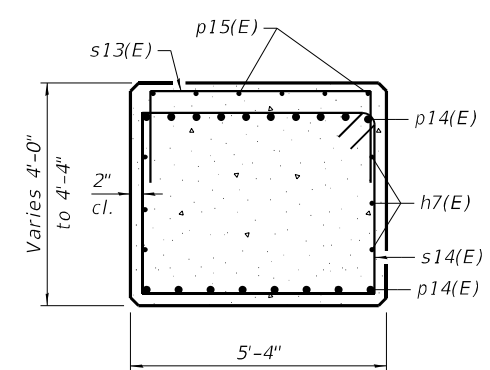
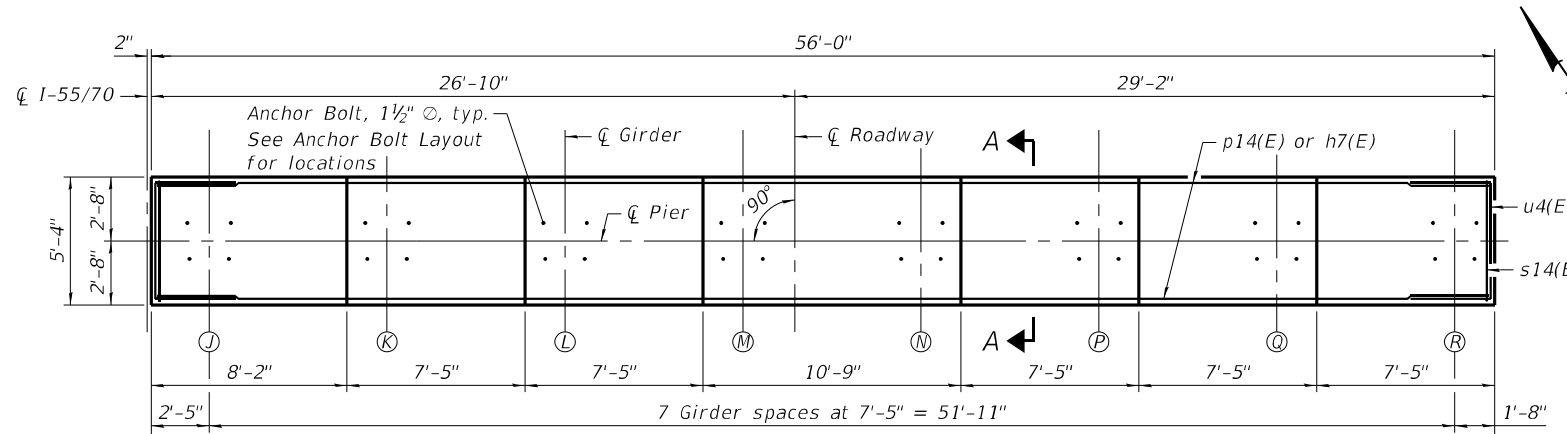

Note:
 Contractor shall adjust column heights in field after verifying footing elevation. Column heights can be adjusted up to 6" without notifying Engineer. If required to meet minimums shown, reinforcement lengths shall be increased.
 All exposed surfaces of new concrete for the pier cap, columns, and wall shall be treated with Concrete Sealer.
 Bars indicatd thus 1x4-#8 etc. indicates 1 line of bars with 4 length per line.

BILL OF MATERIAL

Bar	No.	Size	Length	Shape
h7(E)	12	#6	29'-3"	—
h8(E)	30	#5	29'-1"	—
n(E)	114	#5	4'-3"	—
p14(E)	36	#8	30'-9"	—
p15(E)	6	#5	10'-5"	—
s2(E)	57	#5	16'-7"	□
s13(E)	12	#5	8'-10"	U
s14(E)	54	#5	18'-3"	□
s19(E)	15	#5	12'-4"	U
sp5(E)	5	#5	31'-1"	⋈
u1(E)	12	#5	10'-2"	—
u4(E)	10	#6	13'-6"	—
v8(E)	60	#10	36'-6"	—
Concrete Structures		Cu. Yd.	119.0	
Reinforcement Bars, Epoxy Coated		Pound	21,160	
Concrete Sealer		Sq. Ft.	2,501	

*** Length is height of spiral.

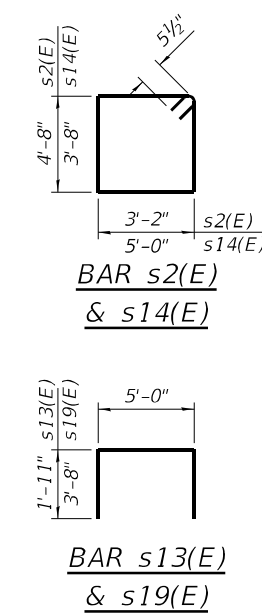
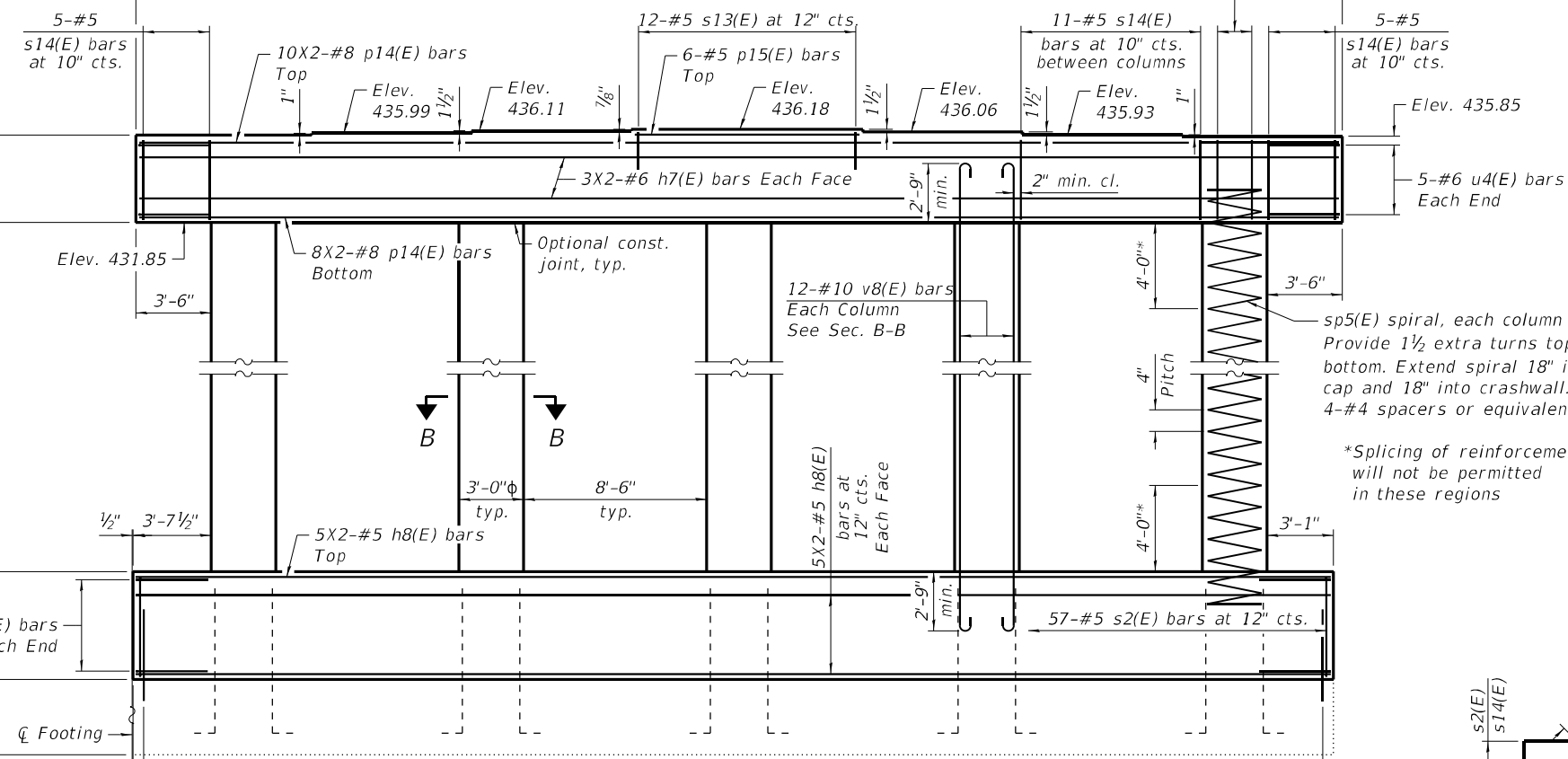
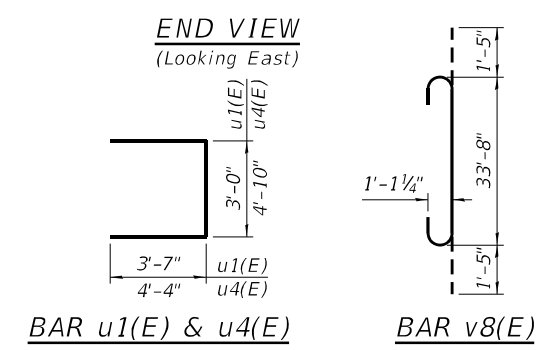
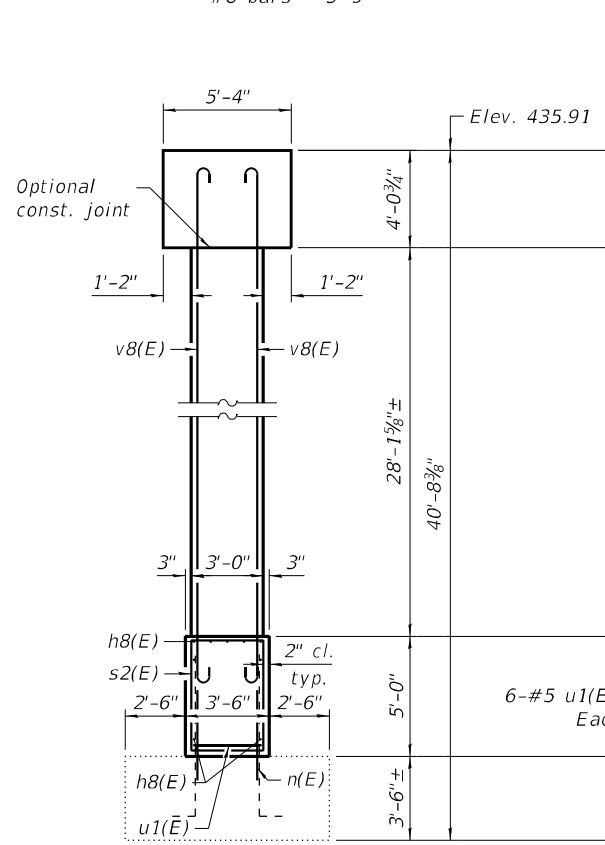

MODEL: Default
 FILE NAME: Z:\15052229_B&O RR Bridge\DNV\Bridge\final\Plotsheets\082001776K02-065-Substructure_Replacement_Pier_13_EB.dgn
 8/13/2024 9:42:02 AM

**Epoxy grout n(E) bars according to Section 584 of the Standard Specifications. Minimum embedment is 12". Embedment depth may be reduced according to the epoxy Manufacturer, if the Contractor provides the Engineer in writing that the shallower embedment depth is capable of developing the full yield strength of the reinforcement at the surface of the existing concrete.

EFK Moen Civil Engineering Design	USER NAME = khll	DESIGNED - ACB	REVISED -	STATE OF ILLINOIS DEPARTMENT OF TRANSPORTATION	SUBSTRUCTURE REPLACEMENT (PIER 13 EB) STRUCTURE NO. 082-0017	F.A.I. RTE.	SECTION	COUNTY	TOTAL SHEETS	SHEET NO.
	PLOT SCALE = 0.1667"/in.	DRAWN - ACB	REVISED -			55/70	82-5VB-R-2	ST. CLAIR	254	203
	PLOT DATE = 8/13/2024	CHECKED - CDL	REVISED -	SHEET 65 OF 114 SHEETS			CONTRACT NO. 76K02			

ILLINOIS FED. AID PROJECT

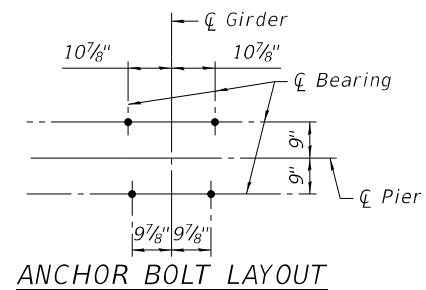

MINIMUM BAR LAP
 #6 bars = 3'-4"
 #8 bars = 5'-9"

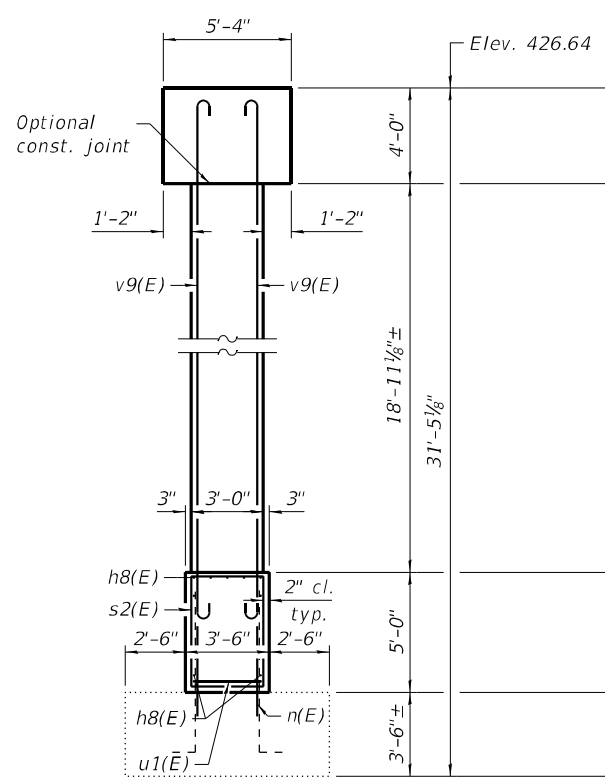

END VIEW
(Looking East)

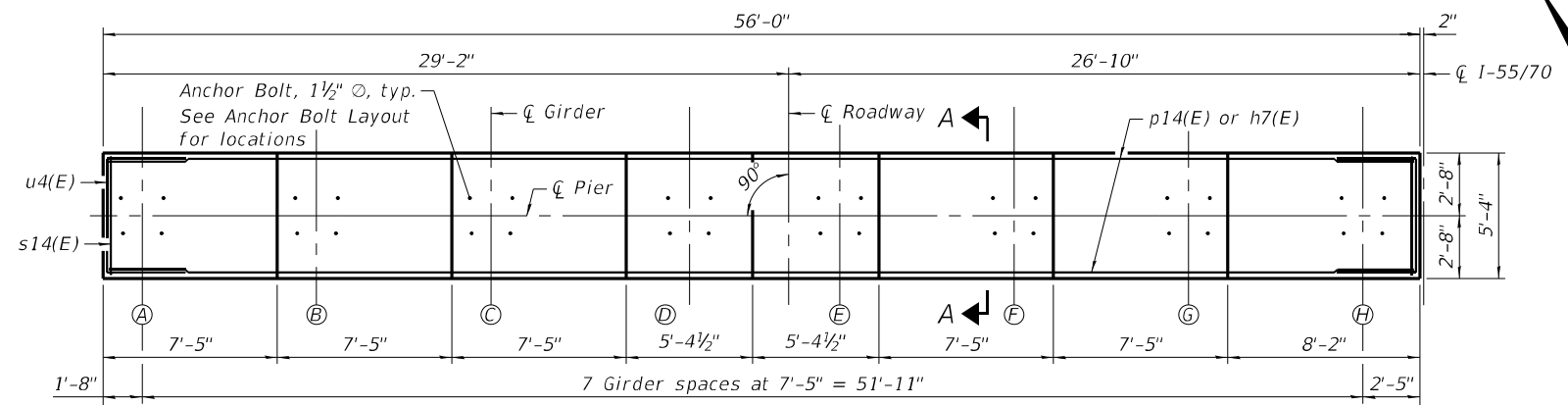
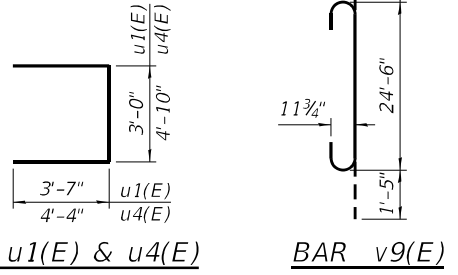

TOP PLAN

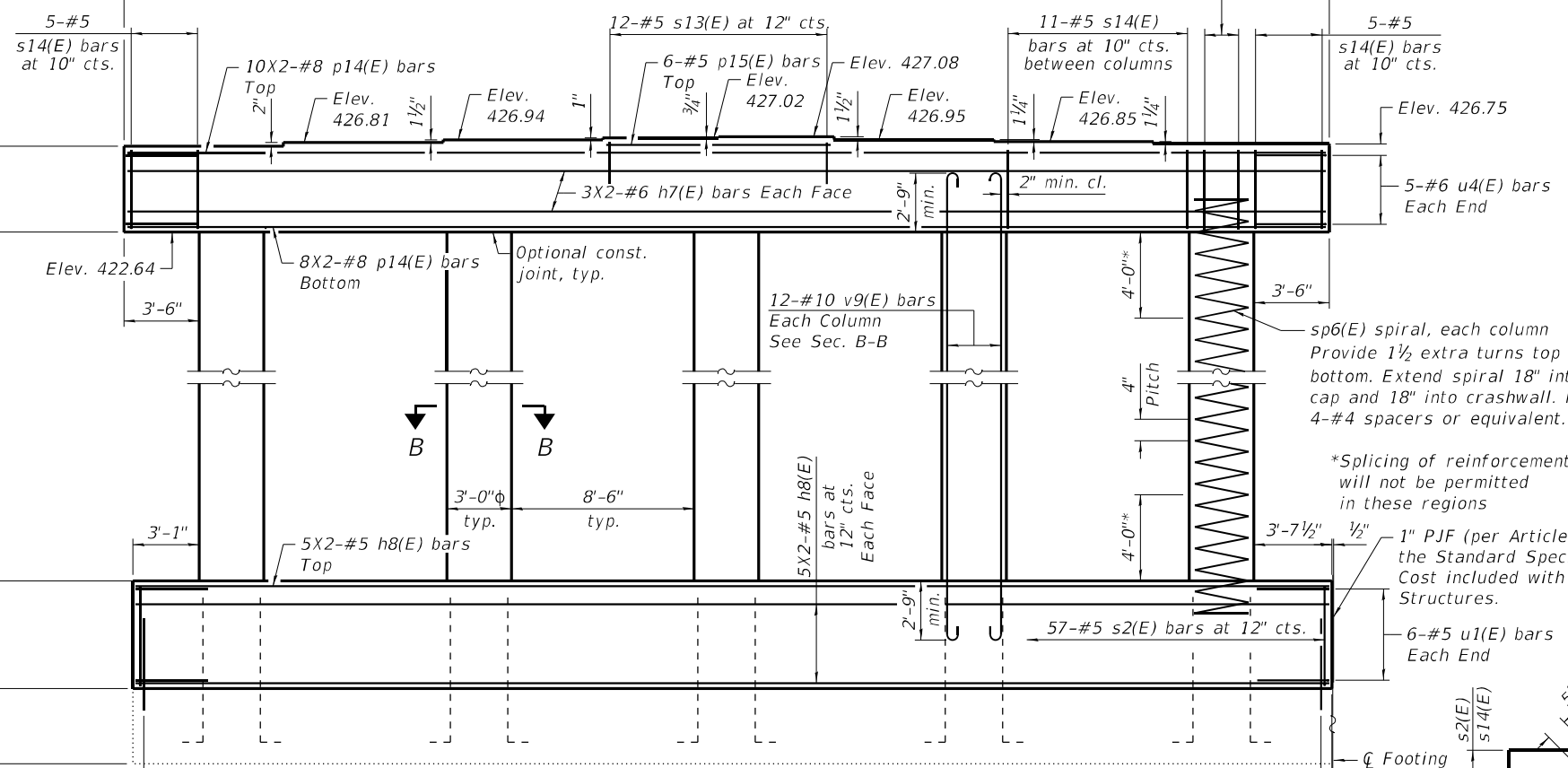

ELEVATION
(Looking North)

FOOTING PLAN

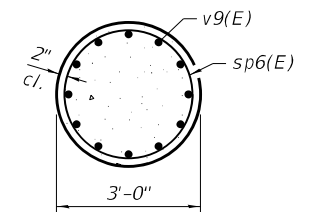
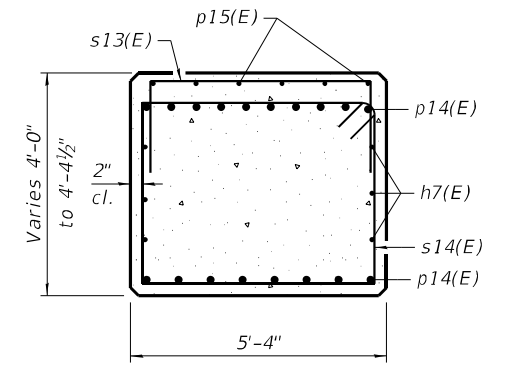

Note:
 Contractor shall adjust column heights in field after verifying footing elevation. Column heights can be adjusted up to 6" without notifying Engineer. If required to meet minimums shown, reinforcement lengths shall be increased.
 All exposed surfaces of new concrete for the pier cap, columns, and wall shall be treated with Concrete Sealer.
 Bars indicated thus 1x4-#8 etc. indicates 1 line of bars with 4 length per line.

BILL OF MATERIAL

Bar	No.	Size	Length	Shape
h7(E)	12	#6	29'-3"	—
h8(E)	30	#5	29'-1"	—
n(E)	114	#5	4'-3"	—
p14(E)	36	#8	30'-9"	—
p15(E)	6	#5	10'-5"	—
s2(E)	57	#5	16'-7"	□
s13(E)	12	#5	8'-10"	U
s14(E)	54	#5	18'-3"	□
s19(E)	15	#5	12'-4"	U
sp6(E)	5	#5	22'-0"	⋈
u1(E)	12	#5	10'-2"	—
u4(E)	10	#6	13'-6"	—
v9(E)	60	#10	27'-4"	—
Concrete Structures		Cu. Yd.		107.6
Reinforcement Bars, Epoxy Coated		Pound		17,630
Concrete Sealer		Sq. Ft.		1,975

*** Length is height of spiral.

**Epoxy grout n(E) bars according to Section 584 of the Standard Specifications. Minimum embedment is 12". Embedment depth may be reduced according to the epoxy Manufacturer, if the Contractor provides the Engineer in writing that the shallower embedment depth is capable of developing the full yield strength of the reinforcement at the surface of the existing concrete.

MODEL: Default
 FILE NAME: Z:\1505229 B&O RR Bridge\DNV\Bridge\final\Plotsheets\082001776K02-066-Substructure- Replacement Pier 16 (WB).dgn
 8/13/2024 9:42:02 AM

EFK Moen
 Civil Engineering Design

USER NAME = khll	DESIGNED - ACB	REVISED -
PLOT SCALE = 0.1667'/in.	CHECKED - CDL	REVISED -
PLOT DATE = 8/13/2024	DRAWN - ACB	REVISED -
	CHECKED - CDL	REVISED -

STATE OF ILLINOIS
 DEPARTMENT OF TRANSPORTATION

SUBSTRUCTURE REPLACEMENT (PIER 16 WB)
 STRUCTURE NO. 082-0017

SHEET 66 OF 114 SHEETS

F.A.I. RTE.	SECTION	COUNTY	TOTAL SHEETS	SHEET NO.
55/70	82-5VB-R-2	ST. CLAIR	254	204
CONTRACT NO. 76K02				
ILLINOIS FED. AID PROJECT				

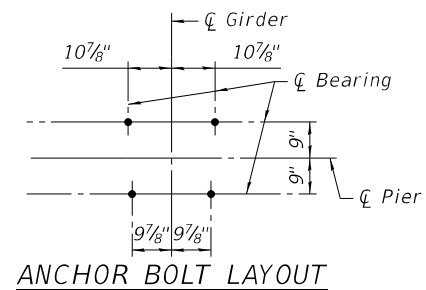

ANCHOR BOLT LAYOUT

MINIMUM BAR LAP

#6 bars = 3'-4"
#8 bars = 5'-9"

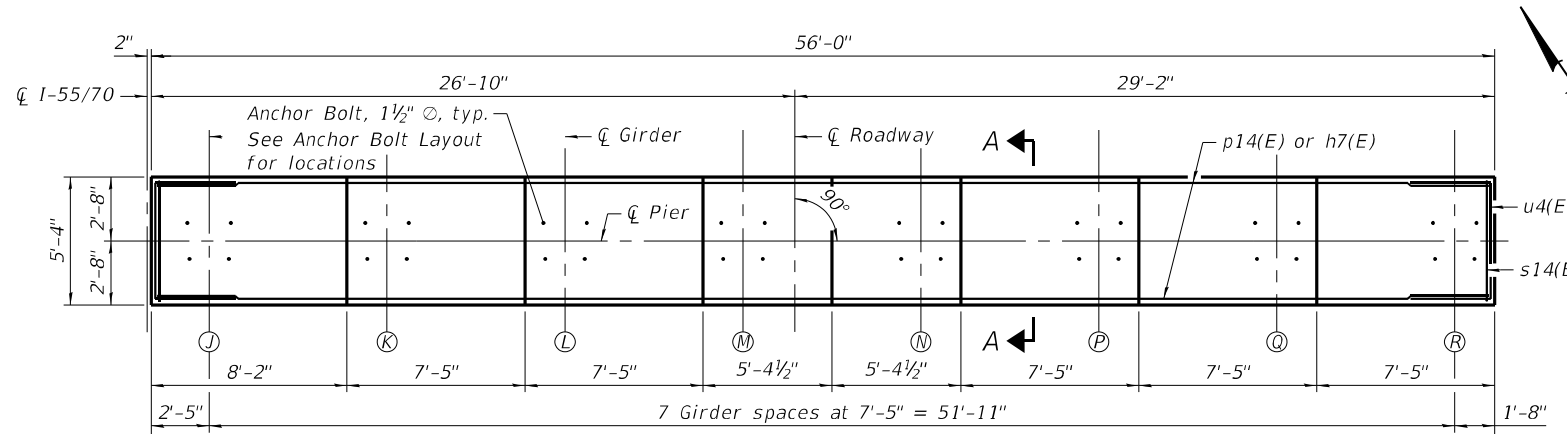

TOP PLAN

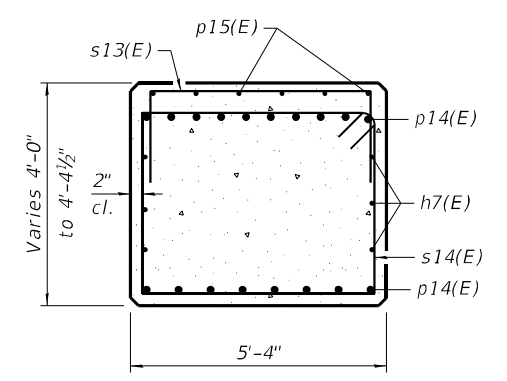

SECTION A-A

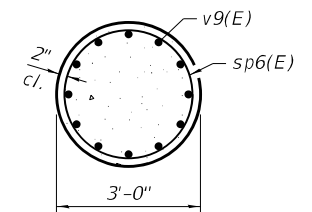

SECTION B-B

Note:
Contractor shall adjust column heights in field after verifying footing elevation. Column heights can be adjusted up to 6" without notifying Engineer. If required to meet minimums shown, reinforcement lengths shall be increased.
All exposed surfaces of new concrete for the pier cap, columns, and wall shall be treated with Concrete Sealer.
Bars indicatd thus 1x4-#8 etc. indicatcs 1 line of bars with 4 length per line.

BILL OF MATERIAL

Bar	No.	Size	Length	Shape
h7(E)	12	#6	29'-3"	—
h8(E)	30	#5	29'-1"	—
n(E)	114	#5	4'-3"	—
p14(E)	36	#8	30'-9"	—
p15(E)	6	#5	10'-5"	—
s2(E)	57	#5	16'-7"	□
s13(E)	12	#5	8'-10"	U
s14(E)	54	#5	18'-3"	□
s19(E)	15	#5	12'-4"	U
sp6(E)	5	#5	22'-0"	⋈
u1(E)	12	#5	10'-2"	—
u4(E)	10	#6	13'-6"	—
v9(E)	60	#10	27'-4"	—
Concrete Structures		Cu. Yd.	107.0	
Reinforcement Bars, Epoxy Coated		Pound	17,630	
Concrete Sealer		Sq. Ft.	1,970	

*** Length is height of spiral.

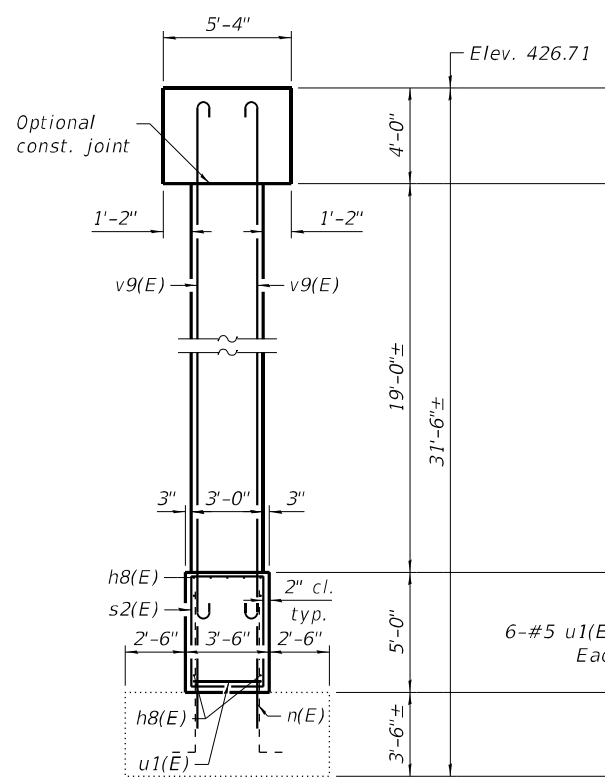

END VIEW (Looking East)

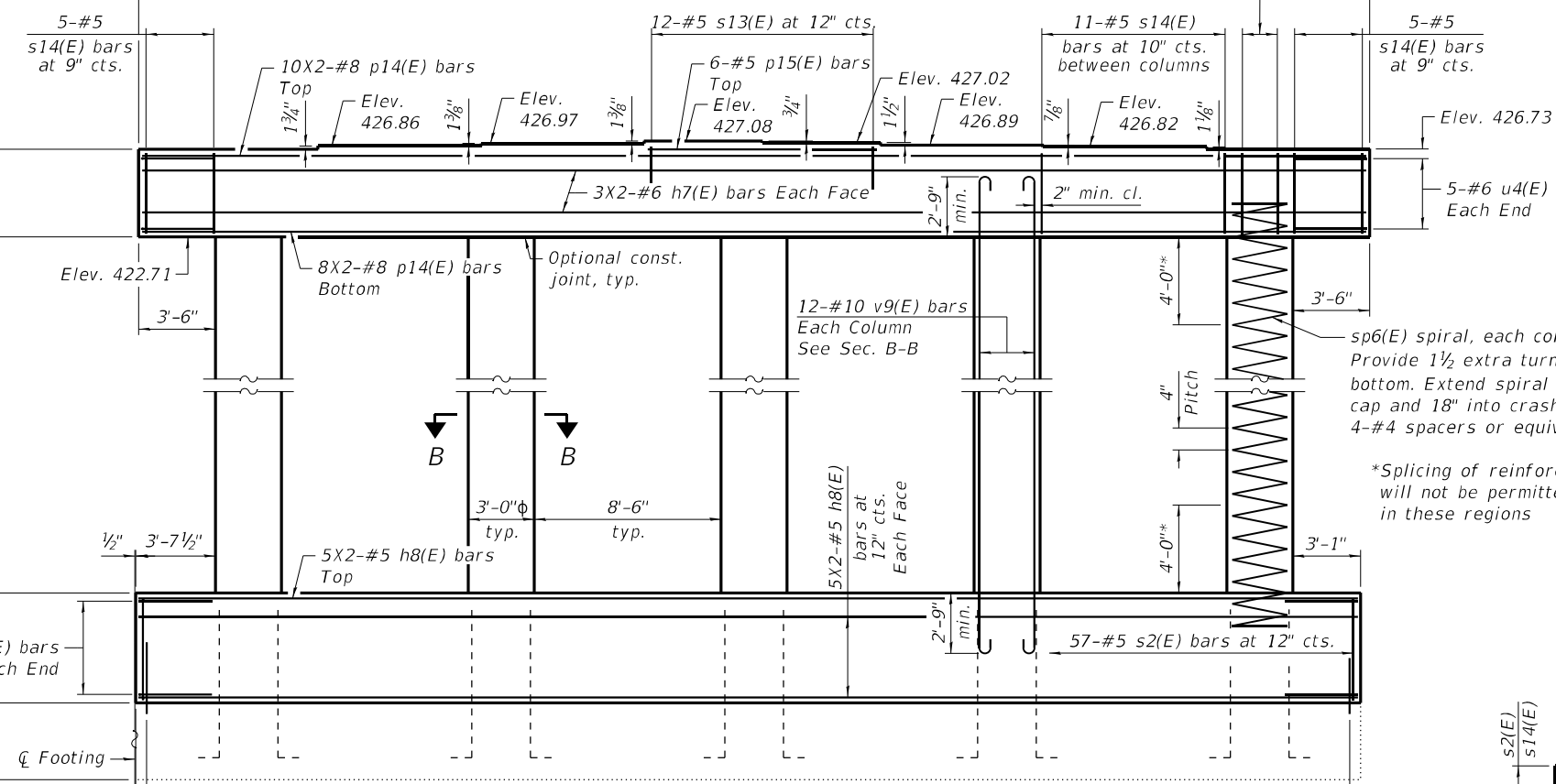
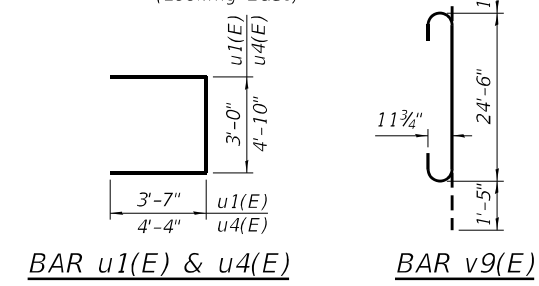

ELEVATION (Looking North)

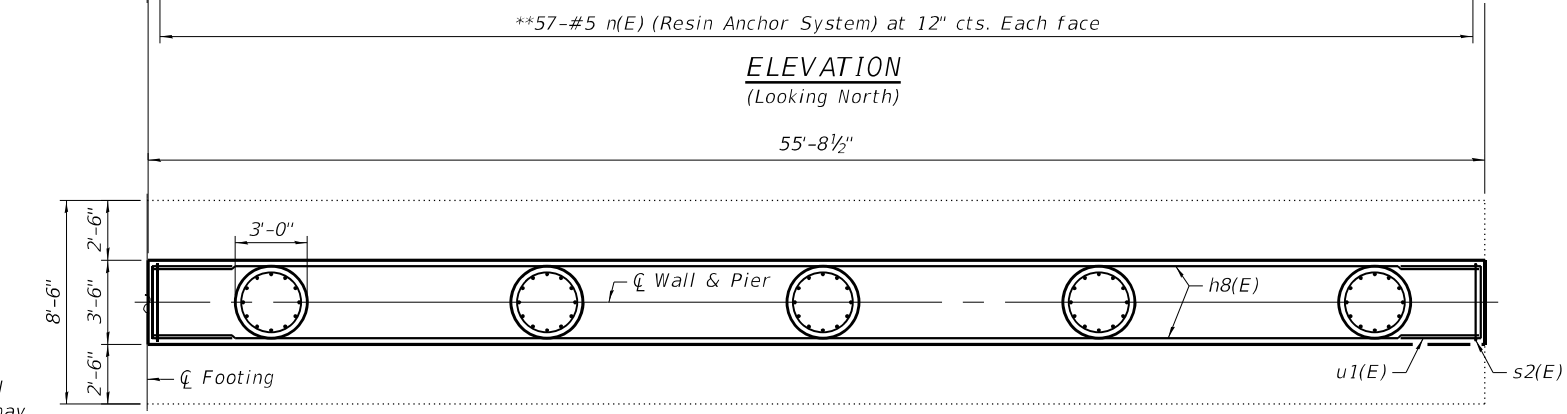

FOOTING PLAN

**Epoxy grout n(E) bars according to Section 584 of the Standard Specifications. Minimum embedment is 12". Embedment depth may be reduced according to the epoxy Manufacturer, if the Contractor provides the Engineer in writing that the shallower embedment depth is capable of developing the full yield strength of the reinforcement at the surface of the existing concrete.

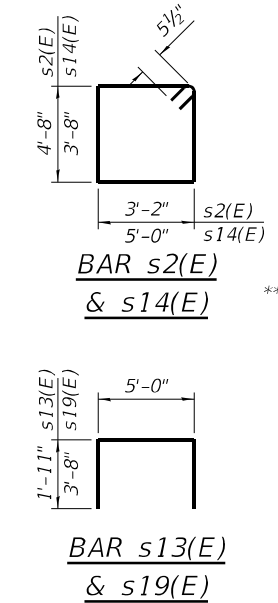

MODEL: Default
FILE NAME: Z:\1505229 BRIDGE\B&O RR Bridge\DNV\Bridge\final\Plotsheets\0820017-76K02-067-Substructure Replacement Pier 16 (EB).dgn
8/13/2024 9:42:03 AM

EFK Moen
Civil Engineering Design

USER NAME = khll	DESIGNED - ACB	REVISED -
PLOT SCALE = 0.1667/1in	CHECKED - CDL	REVISED -
PLOT DATE = 8/13/2024	DRAWN - ACB	REVISED -
	CHECKED - CDL	REVISED -

STATE OF ILLINOIS
DEPARTMENT OF TRANSPORTATION

SUBSTRUCTURE REPLACEMENT (PIER 16 EB)
STRUCTURE NO. 082-0017

SHEET 67 OF 114 SHEETS

F.A.I. RTE.	SECTION	COUNTY	TOTAL SHEETS	SHEET NO.
55/70	82-5VB-R-2	ST. CLAIR	254	205
CONTRACT NO. 76K02				

ILLINOIS FED. AID PROJECT

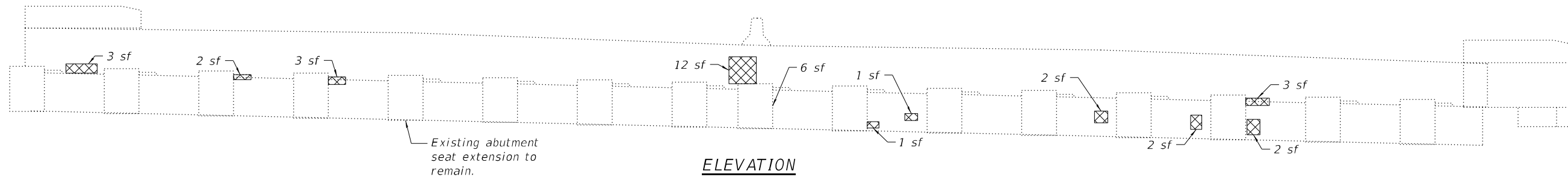

ELEVATION

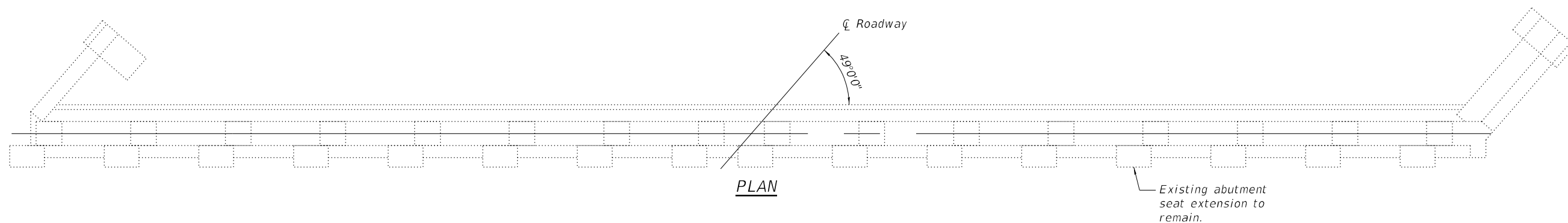

PLAN

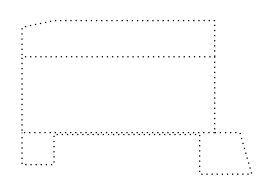

WING WALL ELEVATION (EAST)



WING WALL ELEVATION (WEST)

Notes:
 Repairs may be visible in multiple views, however, the repair is only shown in the most descriptive view.
 Repair locations and quantities shown on Plan or Elevation are approximate and based on the 2020 inspection findings. Allowance of 5 sf has been included in the Bill of Material to account for uncertainty between 2020 inspection findings and present conditions.
 During demolition, it is possible that some repairs may extend below the existing grade.
 It is anticipated that the majority of repairs will be to a depth equal to or less than 5 inches. Some nominal quantity of repair depth greater than 5 inches has been assumed. Resident Engineer to verify all repair locations.

BILL OF MATERIAL

ITEM	UNIT	QUANTITY
Structural Repair of Concrete (Depth Equal to or Less Than 5 Inches)	Sq Ft	37
Structural Repair of Concrete (Depth Greater Than 5 Inches)	Sq Ft	5

 Structural Repair of Concrete

MODEL: Default
 FILE NAME: Z:\1505229_B&O_RR_Bridge\DCN\Bridges\final\Plotsheets\0820017-76K02-068-West_Abutment.dgn

WJE ENGINEERS ARCHITECTS MATERIAL SCIENTISTS
 Wss, Janney, Elstner Associates, Inc.
 330 Pfingsten Road
 Northbrook, Illinois 60062
 847.272.7400 tel | 847.291.9595 fax
 www.wje.com

USER NAME = khill	DESIGNED - SMG	REVISED -
	CHECKED - RAW	REVISED -
PLOT SCALE = 0.1667"/in.	DRAWN - SMG	REVISED -
PLOT DATE = 8/13/2024	CHECKED - RAW	REVISED -

**STATE OF ILLINOIS
 DEPARTMENT OF TRANSPORTATION**

**WEST ABUTMENT REPAIR DETAILS
 STRUCTURE NO. 082-0017**

SHEET 68 OF 114 SHEETS

F.A.I. RTE.	SECTION	COUNTY	TOTAL SHEETS	SHEET NO.
55/70	82-5VB-R-2	ST. CLAIR	254	206
CONTRACT NO. 76K02				
		ILLINOIS	FED. AID PROJECT	

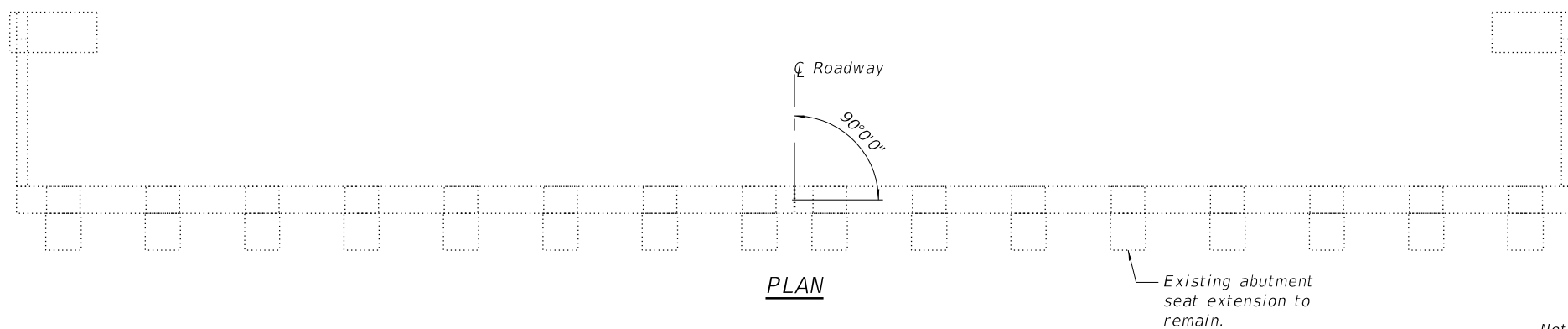
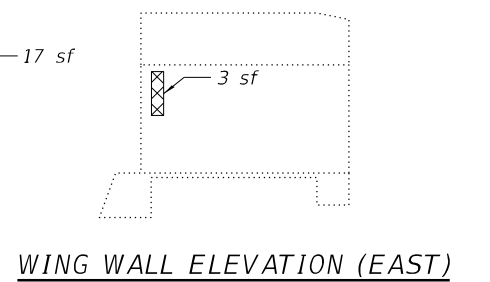
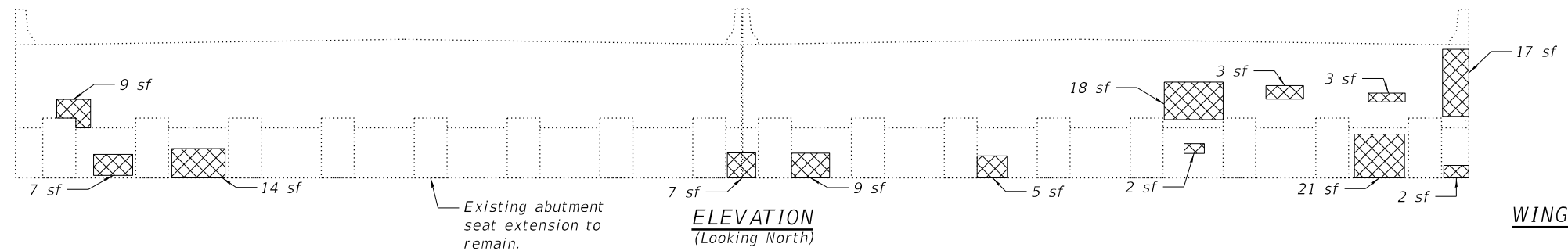
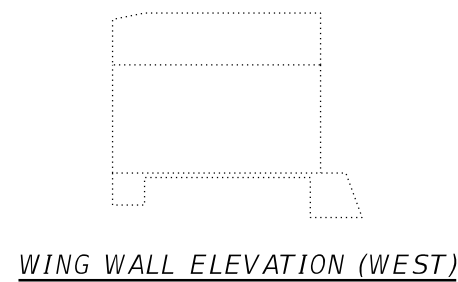
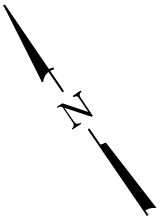

Notes:
 Repairs may be visible in multiple views, however, the repair is only shown in the most descriptive view.
 Repair locations and quantities shown on Plan or Elevation are approximate and based on the 2020 inspection findings. Allowance of 13 sf has been included in Bill of Material to account for uncertainty between 2020 inspection findings and present conditions.
 During demolition, it is possible that some repairs may extend below the existing grade.
 It is anticipated that the majority of repairs will be to a depth equal to or less than 5 inches. Some nominal quantity of repair depth greater than 5 inches has been assumed.
 Resident Engineer to verify all repair locations.

BILL OF MATERIAL

ITEM	UNIT	QUANTITY
Structural Repair of Concrete (Depth Equal to or Less Than 5 Inches)	Sq Ft	119
Structural Repair of Concrete (Depth Greater Than 5 Inches)	Sq Ft	14

Structural Repair of Concrete

MODEL: Default
 FILE NAME: Z:\15052.29 B&O RR Bridge\DCN\Bridg\final\Plotsheets\0820017-76K02-069-East-Abutment.dgn

WJE ENGINEERS ARCHITECTS MATERIAL SCIENTISTS
 Wss, Janney, Elstner Associates, Inc.
 330 Pfingsten Road
 Northbrook, Illinois 60062
 847.272.7400 tel | 847.291.9595 fax
 www.wje.com

USER NAME = khill	DESIGNED - SMG	REVISED -
	CHECKED - RAW	REVISED -
PLOT SCALE = 0.1667" / in.	DRAWN - SMG	REVISED -
PLOT DATE = 8/13/2024	CHECKED - RAW	REVISED -

**STATE OF ILLINOIS
 DEPARTMENT OF TRANSPORTATION**

**EAST ABUTMENT REPAIR DETAILS
 STRUCTURE NO. 082-0017**

SHEET 69 OF 114 SHEETS

F.A.I. RTE.	SECTION	COUNTY	TOTAL SHEETS	SHEET NO.
55/70	82-5VB-R-2	ST. CLAIR	254	207
CONTRACT NO. 76K02				
		ILLINOIS	FED. AID PROJECT	

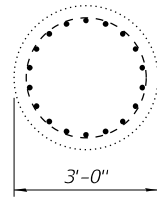

COLUMN CROSS SECTION

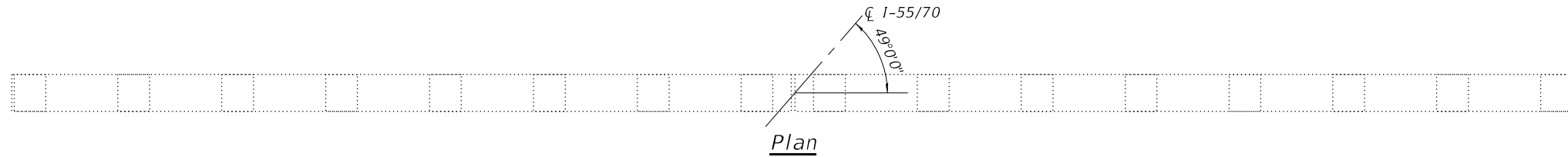

Plan

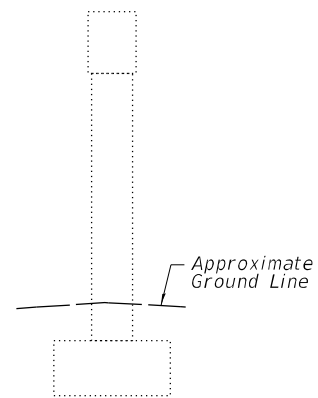
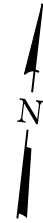

**End View
(Looking East)**

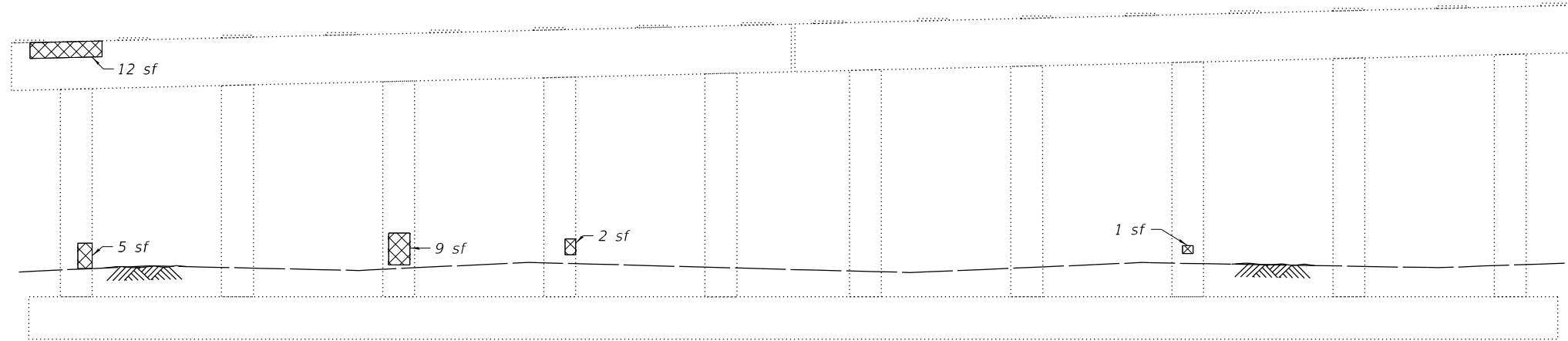

**Elevation
(Looking North)**

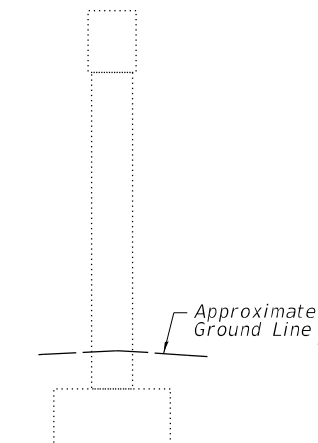

**End View
(Looking West)**

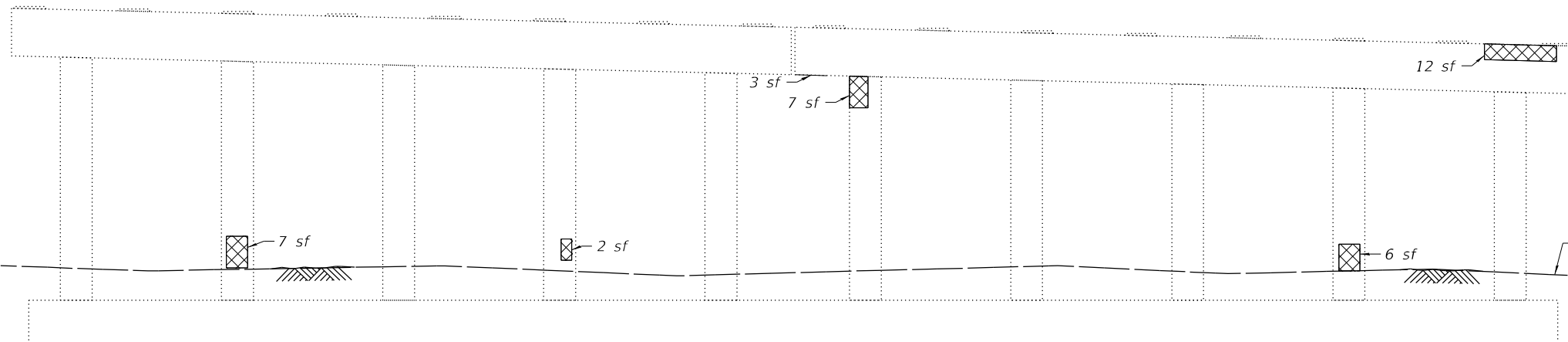

**Elevation
(Looking South)**

Structural Repair of Concrete

Notes:
 Repairs may be visible in multiple views, however, the repair is only shown in the most descriptive view.
 Repair locations and quantities shown on Plan or Elevation are approximate and based on the 2020 inspection findings. Allowance of 7 sf has been included in Bill of Material to account for uncertainty between 2020 inspection findings and present conditions.
 During demolition, it is possible that some repairs may extend below the existing grade.
 It is anticipated that the majority of repairs will be to a depth equal to or less than 5 inches. Some nominal quantity of repair depth greater than 5 inches has been assumed. Resident Engineer to verify all repair locations.

BILL OF MATERIAL

ITEM	UNIT	QUANTITY
Structural Repair of Concrete (Depth Equal to or Less Than 5 Inches)	Sq Ft	65
Structural Repair of Concrete (Depth Greater Than 5 Inches)	Sq Ft	8

MODEL: Default
 FILE NAME: Z:\1505229 B&O RR Bridge\DCN\Bridg\final\Plotsheets\0820017-76K02-070-Pier 1.dgn

WJE ENGINEERS ARCHITECTS MATERIAL SCIENTISTS
 Wss, Janney, Elstner Associates, Inc.
 330 Pfingsten Road
 Northbrook, Illinois 60062
 847.272.7400 tel | 847.291.9595 fax
 www.wje.com

USER NAME = khill	DESIGNED - SMG	REVISED -
PLOT SCALE = 0.1667"/in.	CHECKED - RAW	REVISED -
PLOT DATE = 8/13/2024	DRAWN - SMG	REVISED -
	CHECKED - RAW	REVISED -

**STATE OF ILLINOIS
 DEPARTMENT OF TRANSPORTATION**

**PIER 1 REPAIR DETAILS
 STRUCTURE NO. 082-0017**

SHEET 70 OF 114 SHEETS

F.A.I. RTE.	SECTION	COUNTY	TOTAL SHEETS	SHEET NO.
55/70	82-5VB-R-2	ST. CLAIR	254	208
CONTRACT NO. 76K02				
		ILLINOIS	FED. AID PROJECT	

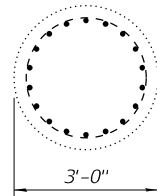

COLUMN CROSS SECTION

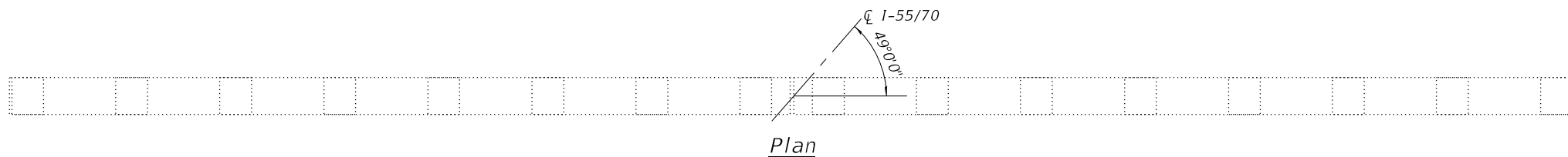

Plan

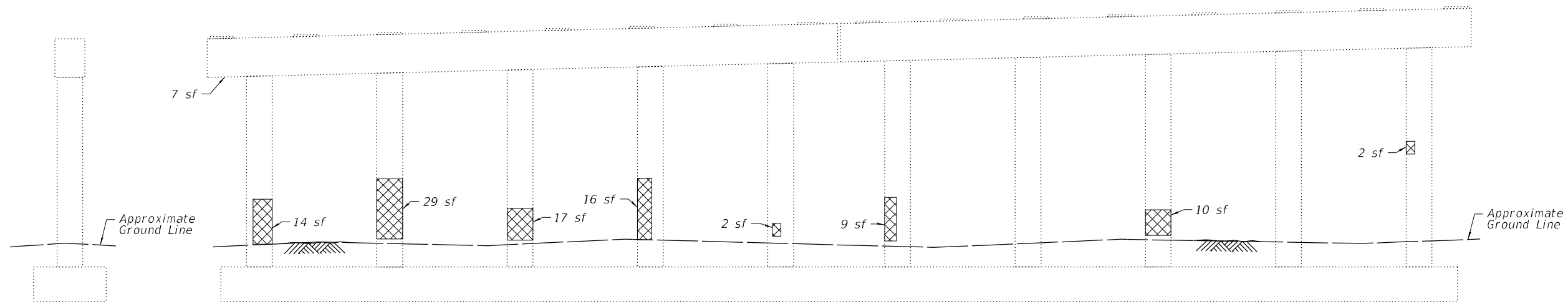
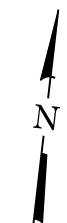

Elevation

(Looking North)

End View

(Looking East)

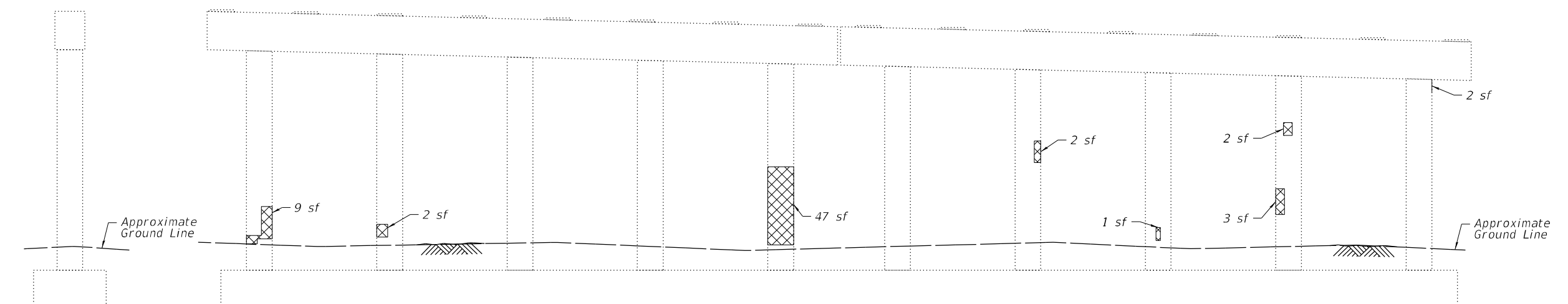

Elevation

(Looking South)

End View

(Looking West)

Structural Repair of Concrete

Notes:
 Repairs may be visible in multiple views, however, the repair is only shown in the most descriptive view.
 Repair locations and quantities shown on Plan or Elevation are approximate and based on the 2020 inspection findings. Allowance of 18 sf has been included in Bill of Material to account for uncertainty between 2020 inspection findings and present conditions.
 During demolition, it is possible that some repairs may extend below the existing grade.
 It is anticipated that the majority of repairs will be to a depth equal to or less than 5 inches. Some nominal quantity of repair depth greater than 5 inches has been assumed. Resident Engineer to verify all repair locations.

BILL OF MATERIAL

ITEM	UNIT	QUANTITY
Structural Repair of Concrete (Depth Equal to or Less Than 5 Inches)	Sq Ft	173
Structural Repair of Concrete (Depth Greater Than 5 Inches)	Sq Ft	19

MODEL: Default
 FILE NAME: Z:\1505229_B&O_RR_Bridge\DCN\Bridg\final\Plotsheets\0820017-76K02-071-Pier_2.dgn

WJE ENGINEERS ARCHITECTS MATERIAL SCIENTISTS
 Wss, Janney, Elstner Associates, Inc.
 330 Pfingsten Road
 Northbrook, Illinois 60062
 847.272.7400 tel | 847.291.9595 fax

USER NAME = khill	DESIGNED - SMG	REVISED -
PLOT SCALE = 0.1667"/in.	CHECKED - RAW	REVISED -
PLOT DATE = 8/13/2024	DRAWN - SMG	REVISED -
	CHECKED - RAW	REVISED -

**STATE OF ILLINOIS
 DEPARTMENT OF TRANSPORTATION**

**PIER 2 REPAIR DETAILS
 STRUCTURE NO. 082-0017**

SHEET 71 OF 114 SHEETS

F.A.I. RTE. 55/70	SECTION 82-5VB-R-2	COUNTY ST. CLAIR	TOTAL SHEETS 254	SHEET NO. 209
CONTRACT NO. 76K02				
		ILLINOIS	FED. AID PROJECT	

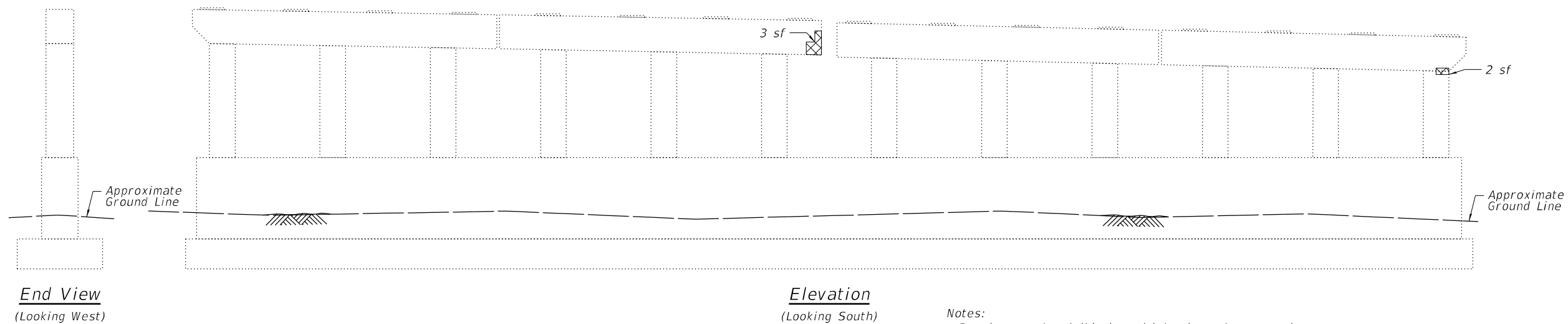
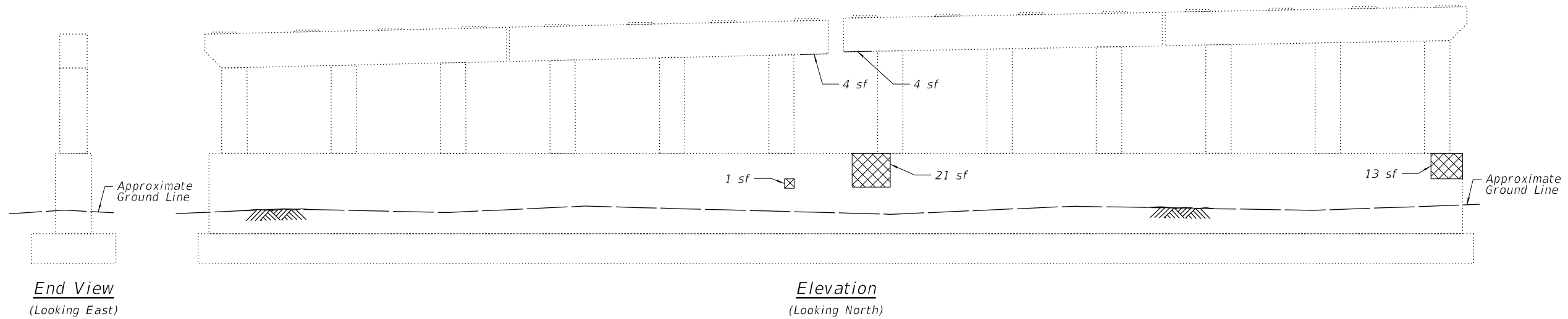
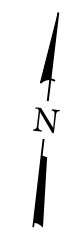
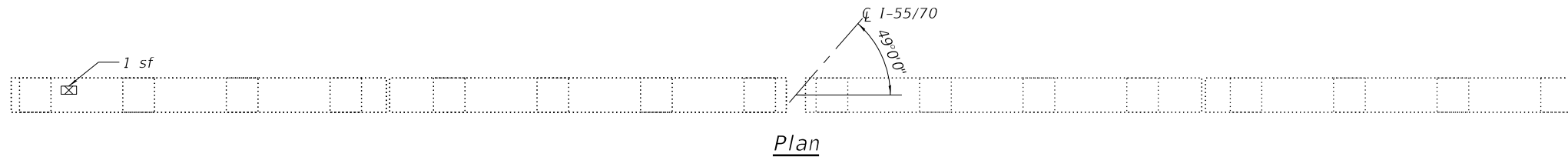
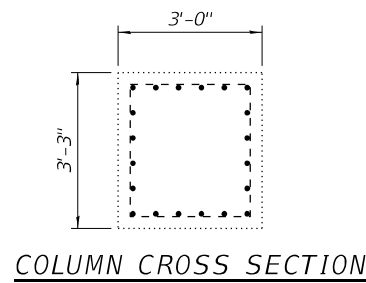

Structural Repair of Concrete

Notes:
 Repairs may be visible in multiple views, however, the repair is only shown in the most descriptive view.
 Repair locations and quantities shown on Plan or Elevation are approximate and based on the 2020 inspection findings. Allowance of 6 sf has been included in Bill of Material to account for uncertainty between 2020 inspection findings and present conditions.
 During demolition, it is possible that some repairs may extend below the existing grade.
 It is anticipated that the majority of repairs will be to a depth equal to or less than 5 inches. Some nominal quantity of repair depth greater than 5 inches has been assumed.
 Resident Engineer to verify all repair locations.
 Reconnecting drainage brackets are incidental to structural repair of concrete.

BILL OF MATERIAL

ITEM	UNIT	QUANTITY
Structural Repair of Concrete (Depth Equal to or Less Than 5 Inches)	Sq Ft	55
Structural Repair of Concrete (Depth Greater Than 5 Inches)	Sq Ft	7

MODEL: Default
 FILE NAME: Z:\1505229 B&O RR Bridge\DCN\Bridg\final\Plotsheets\0820017-76K02-072-Plr_4.dgn

WJE ENGINEERS ARCHITECTS MATERIAL SCIENTISTS
 Wss, Janney, Elstner Associates, Inc.
 330 Pfingsten Road
 Northbrook, Illinois 60062
 847.272.7400 tel | 847.291.9595 fax

USER NAME = khill	DESIGNED - SMG	REVISED -
PLOT SCALE = 0.1667"/in.	CHECKED - RAW	REVISED -
PLOT DATE = 8/13/2024	DRAWN - SMG	REVISED -
	CHECKED - RAW	REVISED -

**STATE OF ILLINOIS
 DEPARTMENT OF TRANSPORTATION**

**PIER 4 REPAIR DETAILS
 STRUCTURE NO. 082-0017**

SHEET 72 OF 114 SHEETS

F.A.I. RTE.	SECTION	COUNTY	TOTAL SHEETS	SHEET NO.
55/70	82-5VB-R-2	ST. CLAIR	254	210
CONTRACT NO. 76K02				
		ILLINOIS	FED. AID PROJECT	

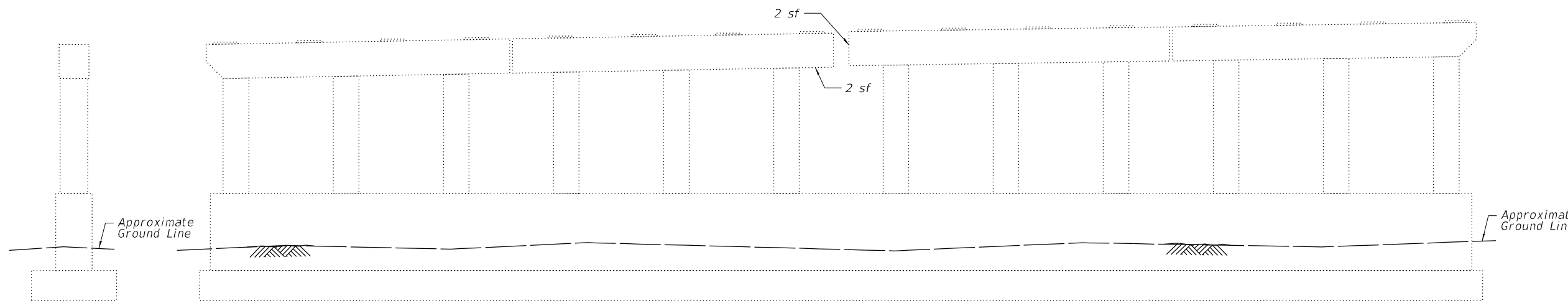
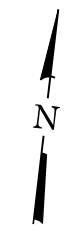
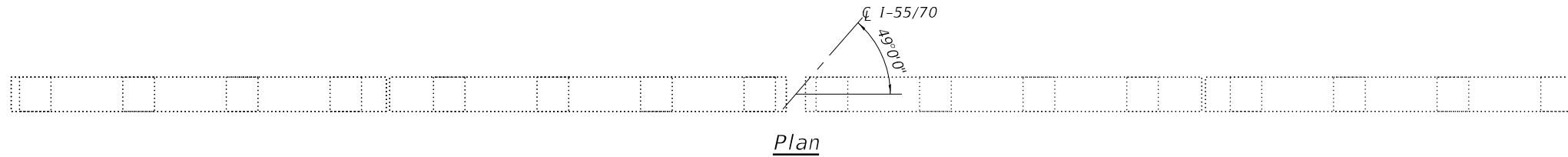
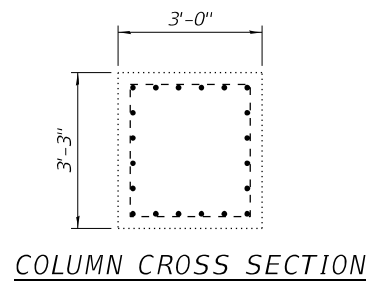

End View (Looking East)

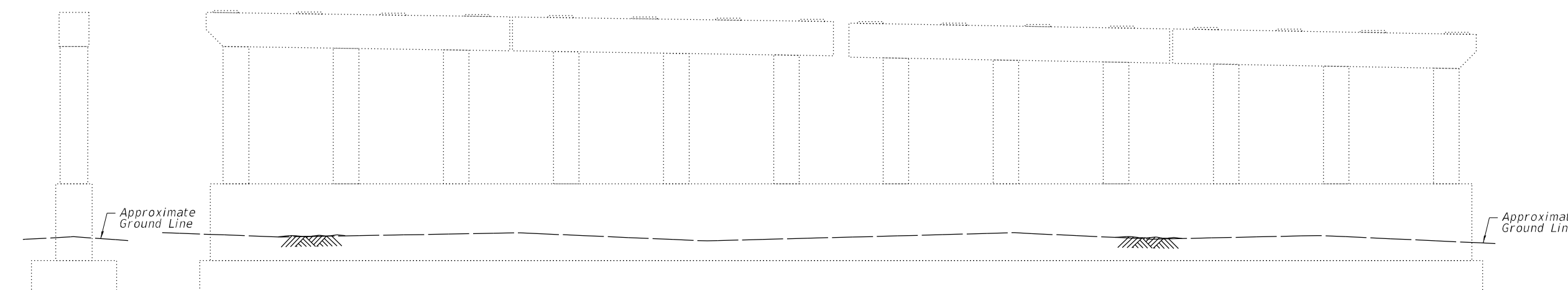

End View (Looking West)

Structural Repair of Concrete

Notes:
 Repairs may be visible in multiple views, however, the repair is only shown in the most descriptive view.
 Repair locations and quantities shown on Plan or Elevation are approximate and based on the 2020 inspection findings. Allowance of 1 sf has been included in Bill of Material to account for uncertainty between 2020 inspection findings and present conditions.
 During demolition, it is possible that some repairs may extend below the existing grade.
 It is anticipated that the majority of repairs will be to a depth equal to or less than 5 inches. Some nominal quantity of repair depth greater than 5 inches has been assumed. Resident Engineer to verify all repair locations.

BILL OF MATERIAL

ITEM	UNIT	QUANTITY
Structural Repair of Concrete (Depth Equal to or Less Than 5 Inches)	Sq Ft	5
Structural Repair of Concrete (Depth Greater Than 5 Inches)	Sq Ft	0

MODEL: Default
 FILE NAME: Z:\1505229_B&O_RR_Bridge\DCN\Bridg\final\Plotsheets\0820017-76K02-073-Plr_5.dgn

WJE ENGINEERS ARCHITECTS MATERIAL SCIENTISTS <i>Wes, Janney, Elstner Associates, Inc.</i> 330 Pfingsten Road Northbrook, Illinois 60062 847.272.7400 tel 847.291.9595 fax www.wje.com	USER NAME = khill	DESIGNED - SMG	REVISED -
	PLOT SCALE = 0.1667"/in.	CHECKED - RAW	REVISED -
	PLOT DATE = 8/13/2024	DRAWN - SMG	REVISED -
		CHECKED - RAW	REVISED -

**STATE OF ILLINOIS
 DEPARTMENT OF TRANSPORTATION**

**PIER 5 REPAIR DETAILS
 STRUCTURE NO. 082-0017**

SHEET 73 OF 114 SHEETS

F.A.I. RTE.	SECTION	COUNTY	TOTAL SHEETS	SHEET NO.
55/70	82-5VB-R-2	ST. CLAIR	254	211
CONTRACT NO. 76K02				
		ILLINOIS	FED. AID PROJECT	

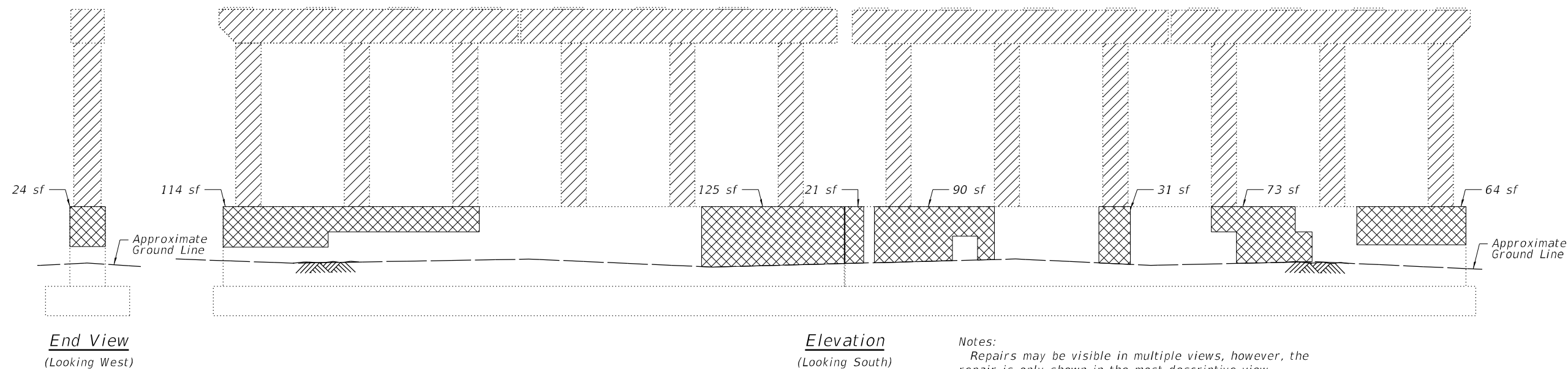
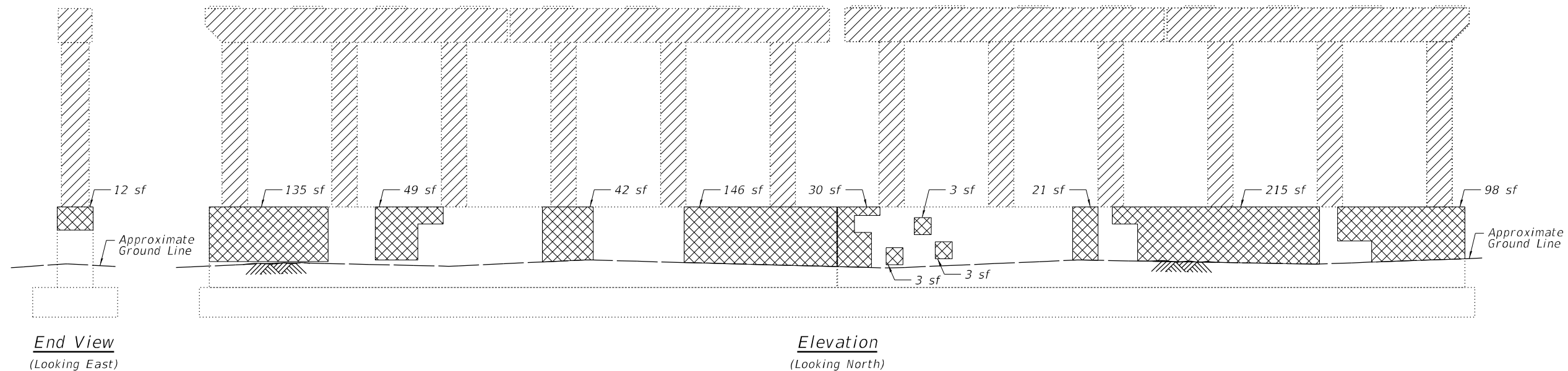
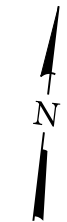
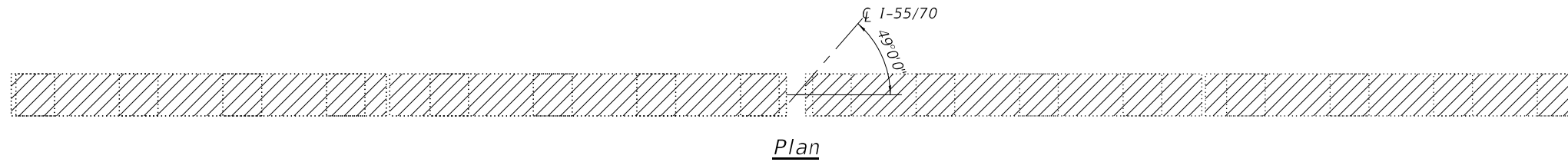
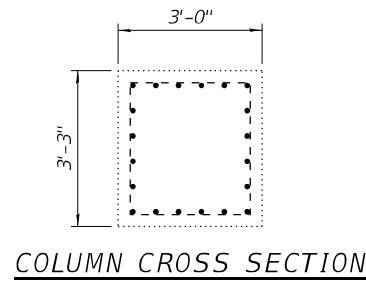

- Structural Repair of Concrete
- Concrete Removal

Notes:
 Repairs may be visible in multiple views, however, the repair is only shown in the most descriptive view.
 Repair locations and quantities shown on Plan or Elevation are approximate and based on the 2020 inspection findings. Allowance of 130 sf has been included in Bill of Material to account for uncertainty between 2020 inspection findings and present conditions.
 During demolition, it is possible that some repairs may extend below the existing grade.
 It is anticipated that the majority of repairs will be to a depth equal to or less than 5 inches. Some nominal quantity of repair depth greater than 5 inches has been assumed.
 Resident Engineer to verify all repair locations.
 For concrete removal details and quantity, see Sheet 39 of 114.

BILL OF MATERIAL

ITEM	UNIT	QUANTITY
Structural Repair of Concrete (Depth Equal to or Less Than 5 Inches)	Sq Ft	1286
Structural Repair of Concrete (Depth Greater Than 5 Inches)	Sq Ft	143

MODEL: Default
 FILE NAME: Z:\1505229 B&O RR Bridge\DCN\Bridg\final\Plotsheets\0820017-76K02-074-Plr_6.dgn

WJE ENGINEERS ARCHITECTS MATERIAL SCIENTISTS
 Wss, Janney, Elstner Associates, Inc.
 330 Pfingsten Road
 Northbrook, Illinois 60062
 847.272.7400 tel | 847.291.9595 fax

USER NAME = khill	DESIGNED - SMG	REVISED -
PLOT SCALE = 0.1667"/in.	CHECKED - RAW	REVISED -
PLOT DATE = 8/13/2024	DRAWN - SMG	REVISED -
	CHECKED - RAW	REVISED -

**STATE OF ILLINOIS
 DEPARTMENT OF TRANSPORTATION**

**PIER 6 REPAIR DETAILS
 STRUCTURE NO. 082-0017**

SHEET 74 OF 114 SHEETS

F.A.I. RTE.	SECTION	COUNTY	TOTAL SHEETS	SHEET NO.
55/70	82-5VB-R-2	ST. CLAIR	254	212
CONTRACT NO. 76K02				
		ILLINOIS	FED. AID PROJECT	

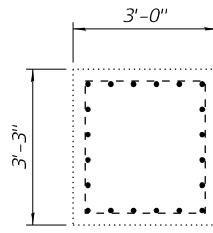

COLUMN CROSS SECTION

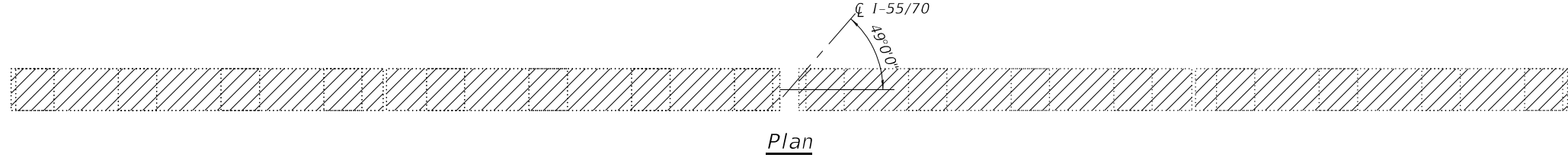

Plan

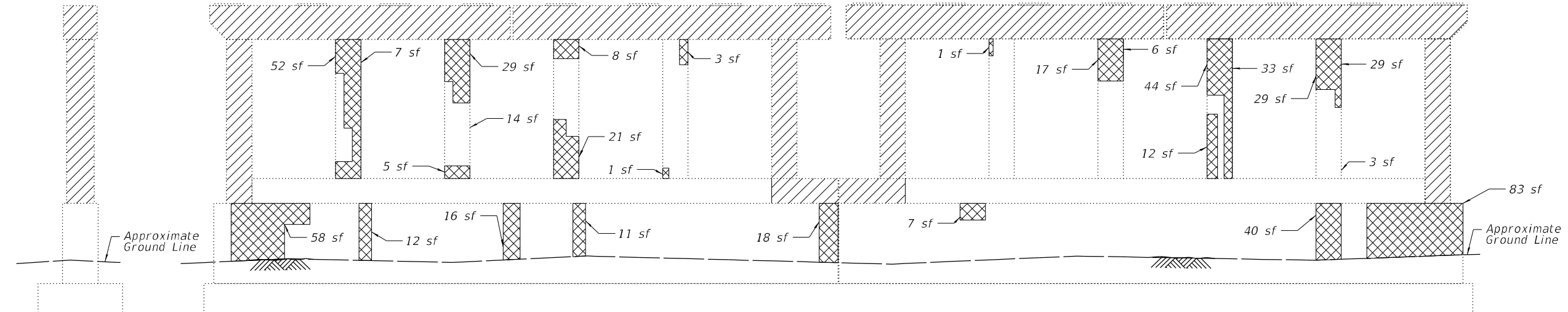

Elevation
(Looking North)

End View
(Looking East)

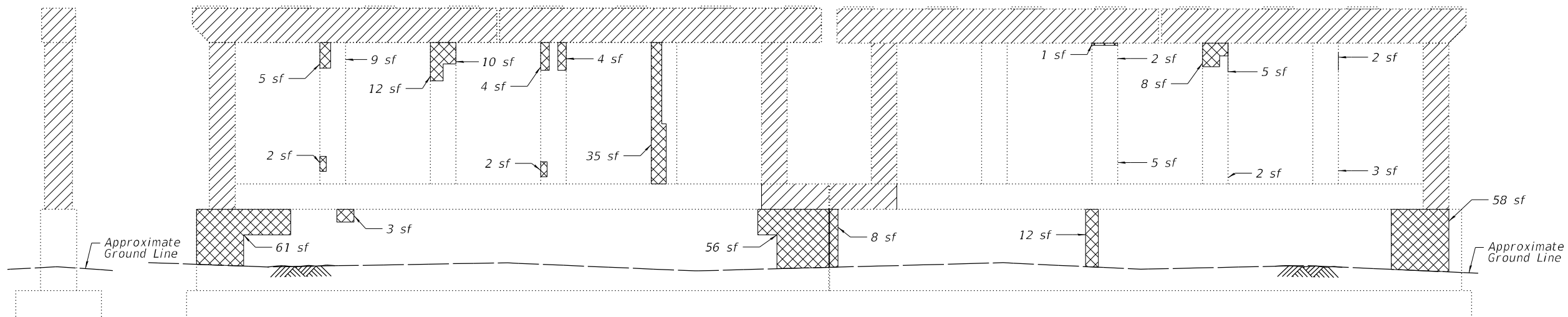

Elevation
(Looking South)

End View
(Looking West)



Notes:
 Repairs may be visible in multiple views, however, the repair is only shown in the most descriptive view.
 Repair locations and quantities shown on Plan or Elevation are approximate and based on the 2020 inspection findings. Allowance of 88 sf has been included in Bill of Material to account for uncertainty between 2020 inspection findings and present conditions.
 During demolition, it is possible that some repairs may extend below the existing grade.
 It is anticipated that the majority of repairs will be to a depth equal to or less than 5 inches. Some nominal quantity of repair depth greater than 5 inches has been assumed.
 Resident Engineer to verify all repair locations.
 For concrete removal details and quantity, see Sheet 40 of 114.

BILL OF MATERIAL

ITEM	UNIT	QUANTITY
Structural Repair of Concrete (Depth Equal to or Less Than 5 Inches)	Sq Ft	860
Structural Repair of Concrete (Depth Greater Than 5 Inches)	Sq Ft	96

MODEL: Default
 FILE NAME: Z:\1505229_B&O_RR_Bridge\DCN\Bridg\final\Plotsheets\0820017-76K02-075-Rev. 7.dgn

WJE ENGINEERS ARCHITECTS MATERIAL SCIENTISTS
 Wss, Janney, Elstner Associates, Inc.
 330 Pfingsten Road
 Northbrook, Illinois 60062
 847.272.7400 tel | 847.291.9595 fax

USER NAME = khill	DESIGNED - SMG	REVISED -
PLOT SCALE = 0.1667"/in.	CHECKED - RAW	REVISED -
PLOT DATE = 8/13/2024	DRAWN - SMG	REVISED -
	CHECKED - RAW	REVISED -

STATE OF ILLINOIS
 DEPARTMENT OF TRANSPORTATION

PIER 7 REPAIR DETAILS
 STRUCTURE NO. 082-0017

SHEET 75 OF 114 SHEETS

F.A.I. RTE.	SECTION	COUNTY	TOTAL SHEETS	SHEET NO.
55/70	82-5VB-R-2	ST. CLAIR	254	213
CONTRACT NO. 76K02				
ILLINOIS		FED. AID PROJECT		

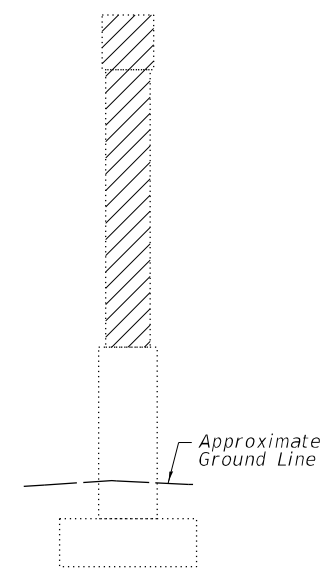
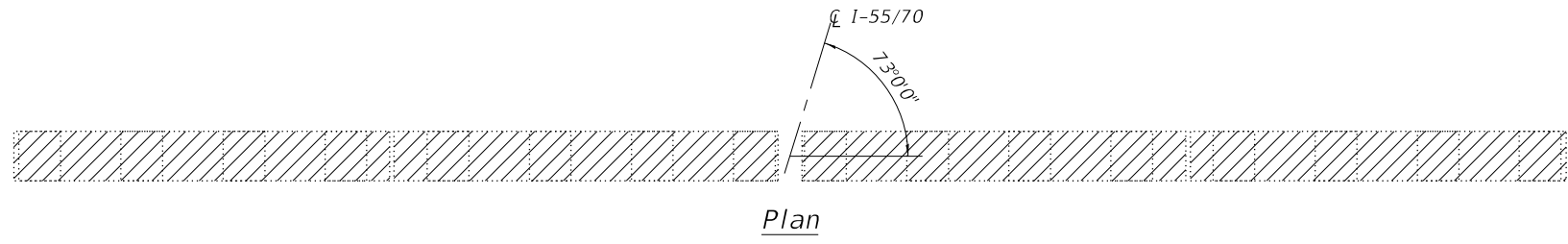
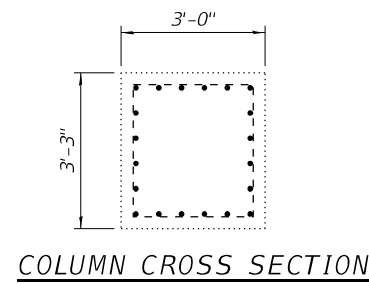

End View
(Looking East)

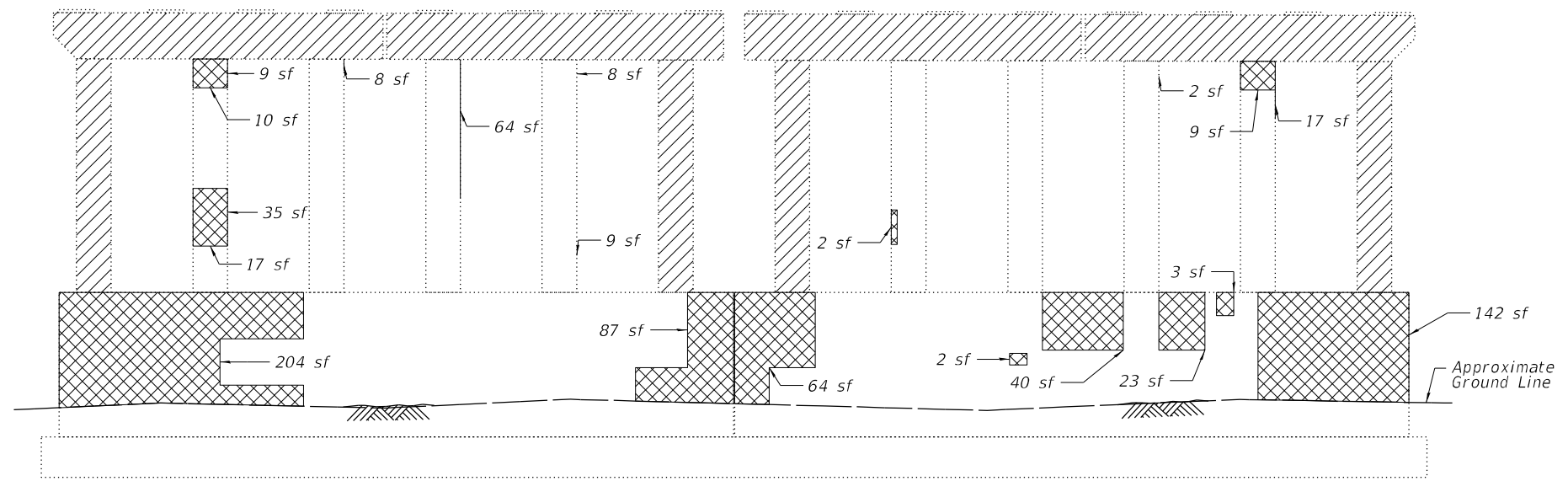

Elevation
(Looking North)

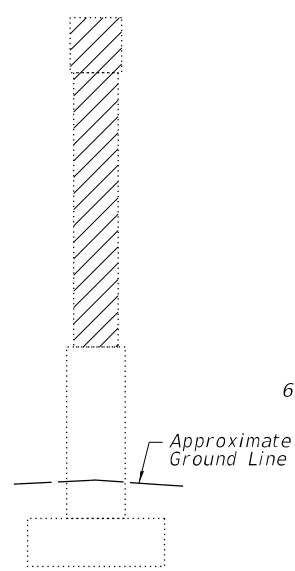

End View
(Looking West)

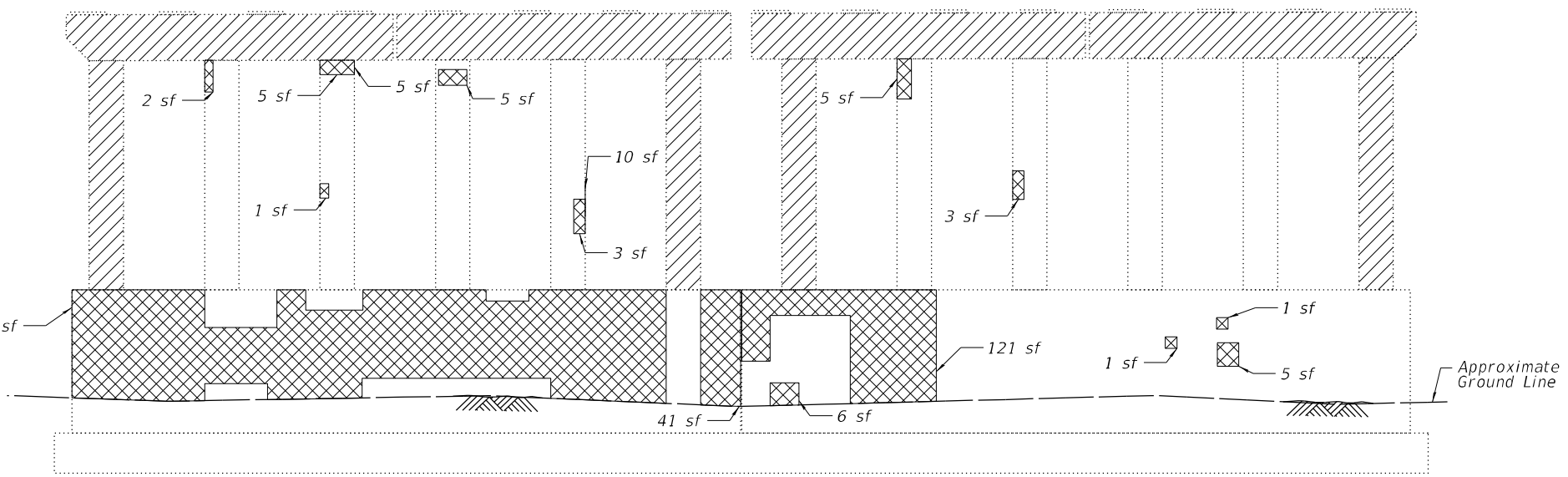

Elevation
(Looking South)

Structural Repair of Concrete
 Concrete Removal

Notes:
 Repairs may be visible in multiple views, however, the repair is only shown in the most descriptive view.
 Repair locations and quantities shown on Plan or Elevation are approximate and based on the 2020 inspection findings. Allowance of 163 sf has been included in Bill of Material to account for uncertainty between 2020 inspection findings and present conditions.
 During demolition, it is possible that some repairs may extend below the existing grade.
 It is anticipated that the majority of repairs will be to a depth equal to or less than 5 inches. Some nominal quantity of repair depth greater than 5 inches has been assumed.
 Resident Engineer to verify all repair locations.
 For concrete removal details and quantity, see Sheet 41 of 114.

BILL OF MATERIAL

ITEM	UNIT	QUANTITY
Structural Repair of Concrete (Depth Equal to or Less Than 5 Inches)	Sq Ft	1606
Structural Repair of Concrete (Depth Greater Than 5 Inches)	Sq Ft	179

MODEL: Default
 FILE NAME: Z:\15052.29 B&O RR Bridge\DCN\Bridg\final\Plot\sheet\0820017-76K02-076-Pier_8.dgn
 WJE ENGINEERS ARCHITECTS MATERIAL SCIENTISTS
 Wss, Janney, Elstner Associates, Inc.
 330 Pfingsten Road
 Northbrook, Illinois 60062
 847.272.7400 tel | 847.291.9595 fax
 www.wje.com

USER NAME = khill	DESIGNED - SMG	REVISED -
PLOT SCALE = 0.1667"/in.	CHECKED - RAW	REVISED -
PLOT DATE = 8/13/2024	DRAWN - SMG	REVISED -
	CHECKED - RAW	REVISED -

STATE OF ILLINOIS
 DEPARTMENT OF TRANSPORTATION

PIER 8 REPAIR DETAILS
 STRUCTURE NO. 082-0017

SHEET 76 OF 114 SHEETS

F.A.I. RTE.	SECTION	COUNTY	TOTAL SHEETS	SHEET NO.
55/70	82-5VB-R-2	ST. CLAIR	254	214
CONTRACT NO. 76K02				
ILLINOIS		FED. AID PROJECT		

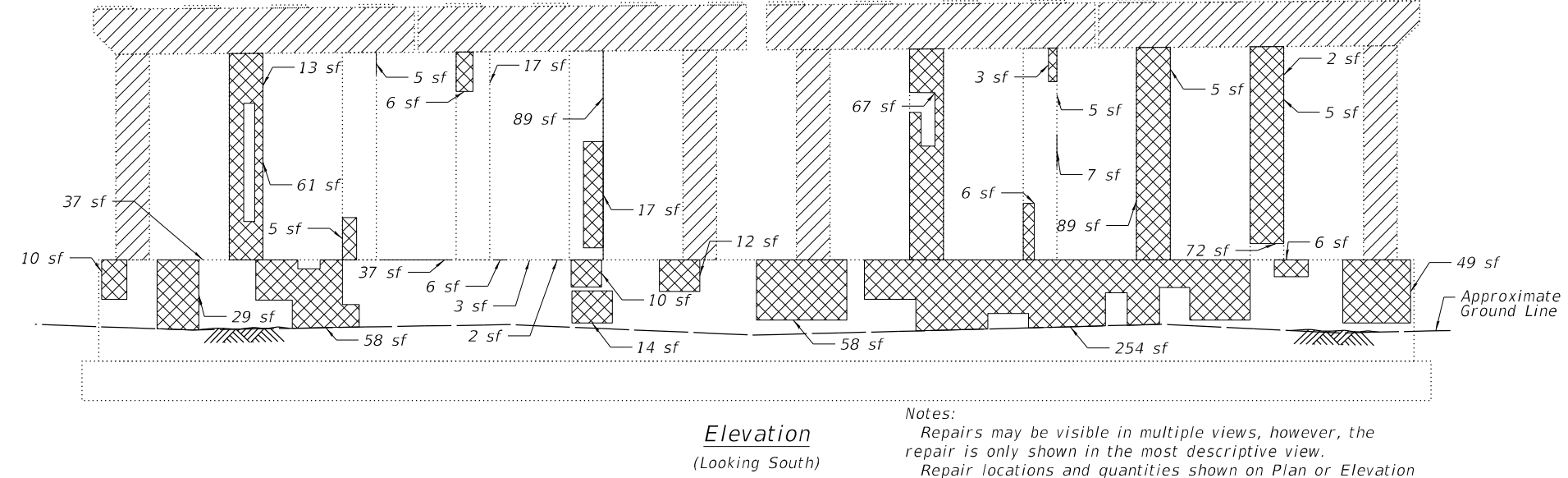
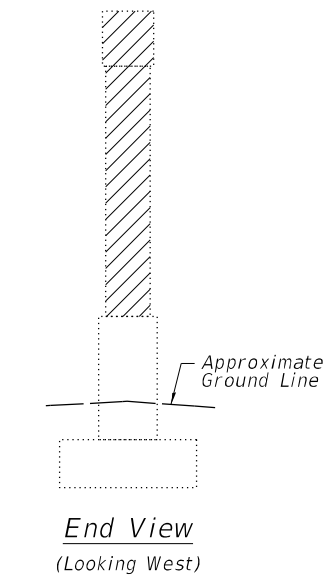
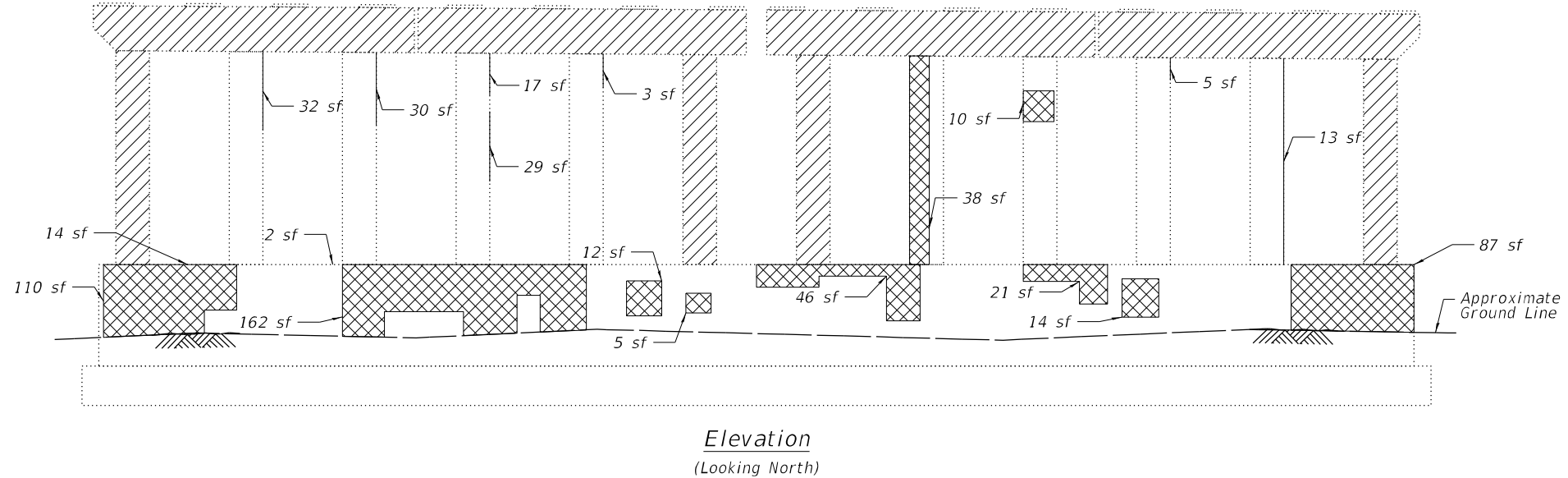
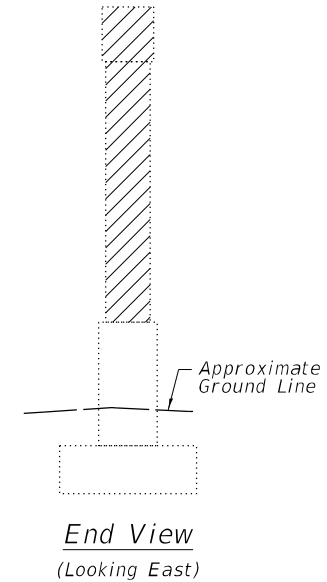
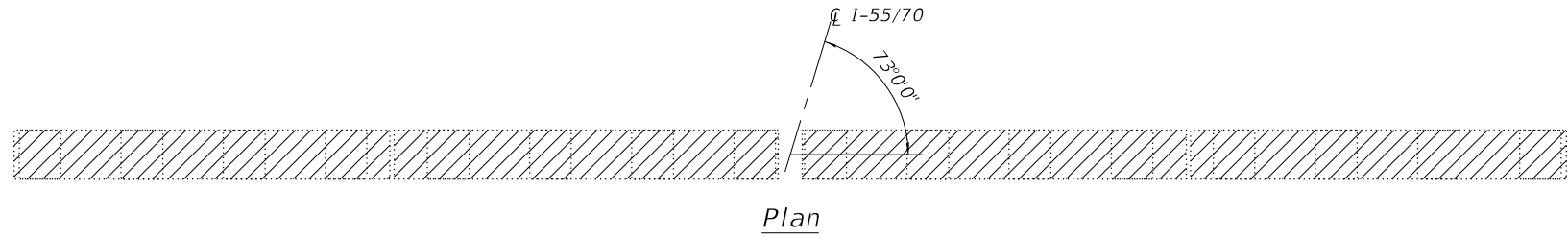
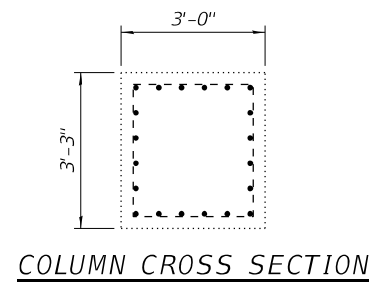

- Structural Repair of Concrete
- Concrete Removal

Notes:
 Repairs may be visible in multiple views, however, the repair is only shown in the most descriptive view.
 Repair locations and quantities shown on Plan or Elevation are approximate and based on the 2020 inspection findings. Allowance of 172 sf has been included in Bill of Material to account for uncertainty between 2020 inspection findings and present conditions.
 During demolition, it is possible that some repairs may extend below the existing grade.
 It is anticipated that the majority of repairs will be to a depth equal to or less than 5 inches. Some nominal quantity of repair depth greater than 5 inches has been assumed. Resident Engineer to verify all repair locations.
 For concrete removal details and quantity, see Sheet 42 of 114.

BILL OF MATERIAL

ITEM	UNIT	QUANTITY
Structural Repair of Concrete (Depth Equal to or Less Than 5 Inches)	Sq Ft	1692
Structural Repair of Concrete (Depth Greater Than 5 Inches)	Sq Ft	189

MODEL: Default
 FILE NAME: Z:\15052.29 B&O RR Bridge\DCN\Bridg\final\Plotsheets\0820017-76K02-077-Pier_9.dgn

WJE ENGINEERS ARCHITECTS MATERIAL SCIENTISTS
 Wss, Janney, Elstner Associates, Inc.
 330 Pfingsten Road
 Northbrook, Illinois 60062
 847.272.7400 tel | 847.291.9595 fax

USER NAME = khill	DESIGNED - SMG	REVISED -
PLOT SCALE = 0.1667"/in.	CHECKED - RAW	REVISED -
PLOT DATE = 8/13/2024	DRAWN - SMG	REVISED -
	CHECKED - RAW	REVISED -

**STATE OF ILLINOIS
 DEPARTMENT OF TRANSPORTATION**

**PIER 9 REPAIR DETAILS
 STRUCTURE NO. 082-0017**

SHEET 77 OF 114 SHEETS

F.A.I. RTE.	SECTION	COUNTY	TOTAL SHEETS	SHEET NO.
55/70	82-5VB-R-2	ST. CLAIR	254	215
CONTRACT NO. 76K02				
ILLINOIS		FED. AID PROJECT		

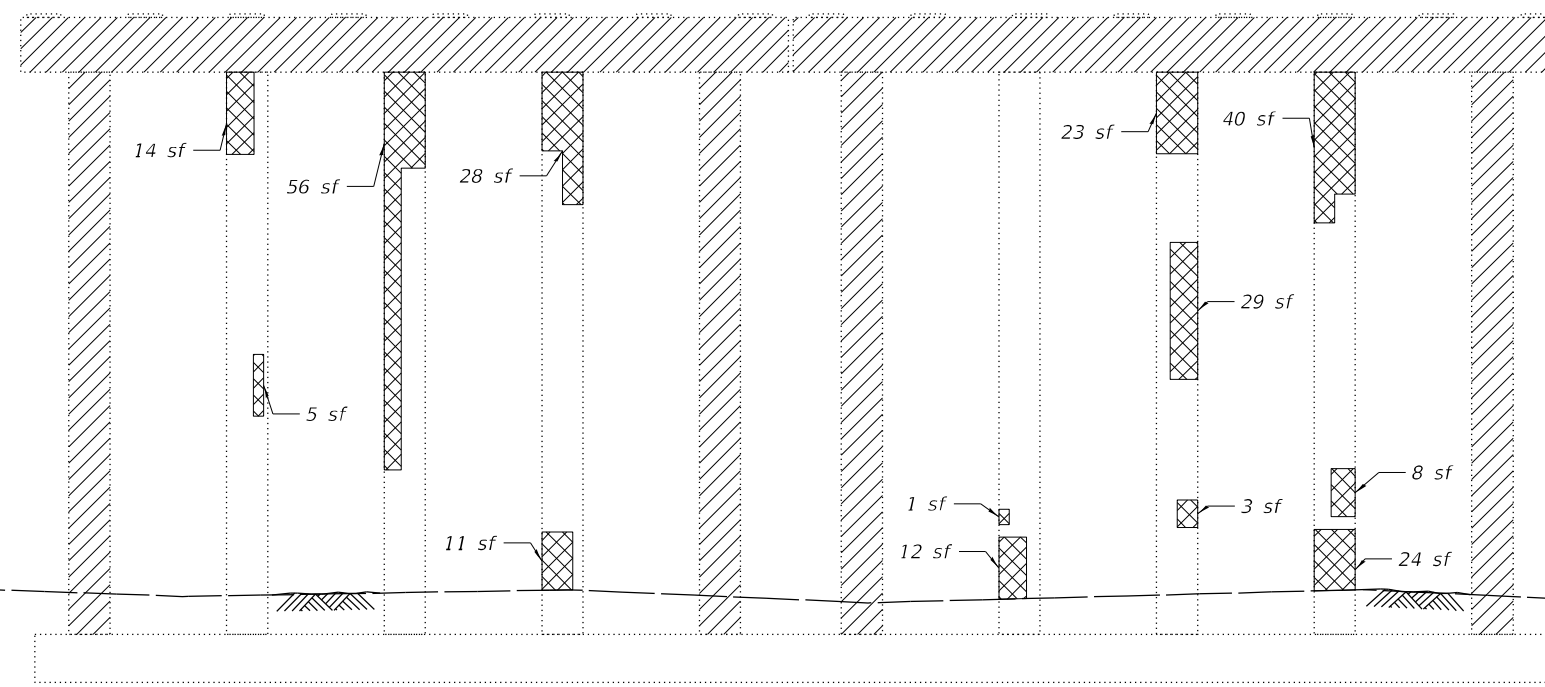
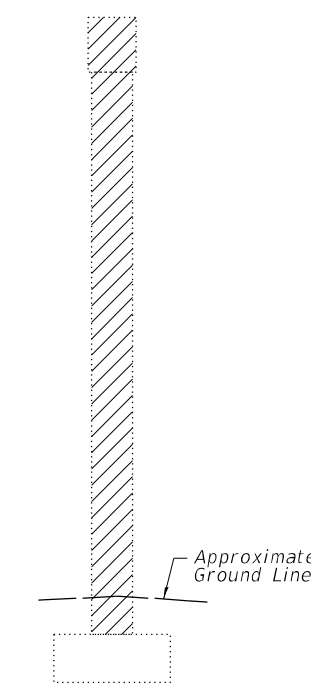
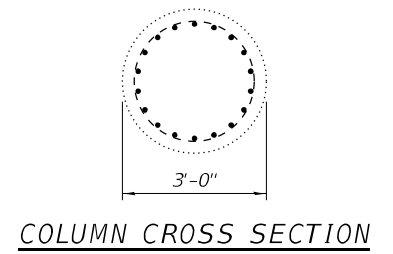
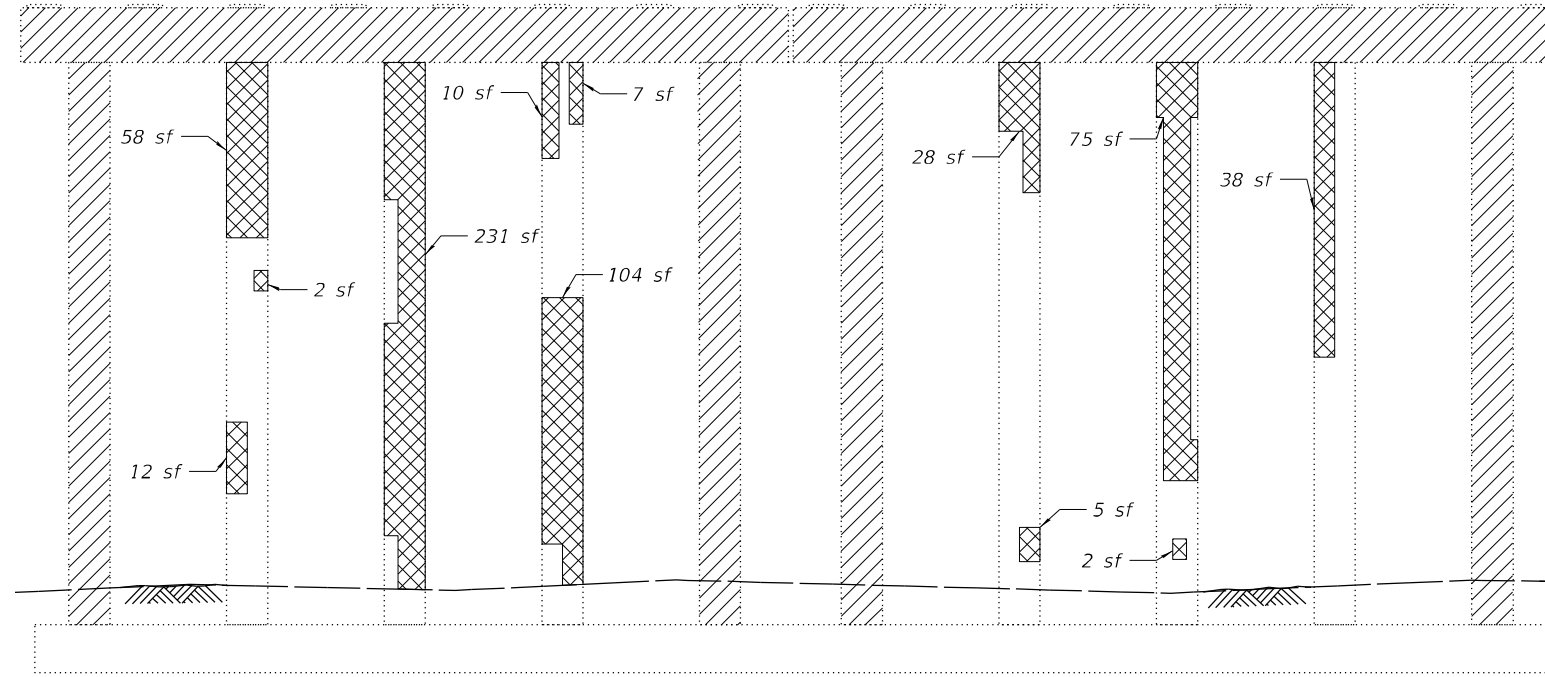
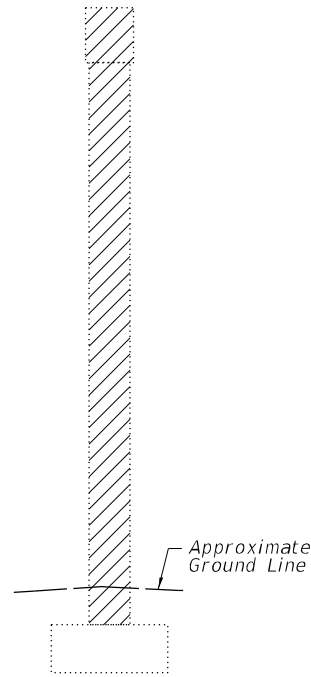
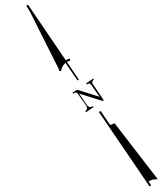
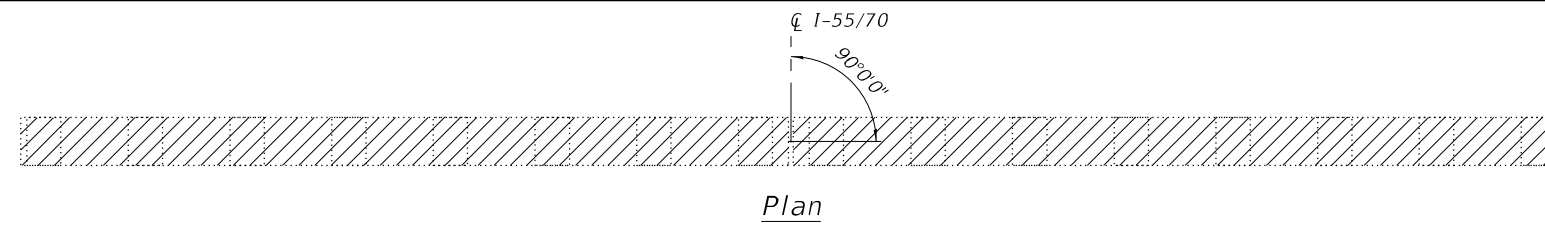

- Structural Repair of Concrete
- Concrete Removal

Notes:
 Repairs may be visible in multiple views, however, the repair is only shown in the most descriptive view.
 Repair locations and quantities shown on Plan or Elevation are approximate and based on the 2020 inspection findings. Allowance of 84 sf has been included in Bill of Material to account for uncertainty between 2020 inspection findings and present conditions.
 During demolition, it is possible that some repairs may extend below the existing grade.
 It is anticipated that the majority of repairs will be to a depth equal to or less than 5 inches. Some nominal quantity of repair depth greater than 5 inches has been assumed. Resident Engineer to verify all repair locations.
 For concrete removal details and quantity, see Sheet 43 of 114.

BILL OF MATERIAL

ITEM	UNIT	QUANTITY
Structural Repair of Concrete (Depth Equal to or Less Than 5 Inches)	Sq Ft	818
Structural Repair of Concrete (Depth Greater Than 5 Inches)	Sq Ft	92

MODEL: Default
 FILE NAME: Z:\15052.29 B&O RR Bridge\DCN\Bridg\final\Plotsheets\0820017-76K02-078-Pier_10.dgn

WJE ENGINEERS ARCHITECTS MATERIAL SCIENTISTS
 Wss, Janney, Elstner Associates, Inc.
 330 Pfingsten Road
 Northbrook, Illinois 60062
 847.272.7400 tel | 847.291.9595 fax

USER NAME = khill	DESIGNED - SMG	REVISED -
PLOT SCALE = 0.1667"/in.	CHECKED - RAW	REVISED -
PLOT DATE = 8/13/2024	DRAWN - SMG	REVISED -
	CHECKED - RAW	REVISED -

**STATE OF ILLINOIS
 DEPARTMENT OF TRANSPORTATION**

**PIER 10 REPAIR DETAILS
 STRUCTURE NO. 082-0017**

SHEET 78 OF 114 SHEETS

F.A.I. RTE.	SECTION	COUNTY	TOTAL SHEETS	SHEET NO.
55/70	82-5VB-R-2	ST. CLAIR	254	216
CONTRACT NO. 76K02				
ILLINOIS		FED. AID PROJECT		

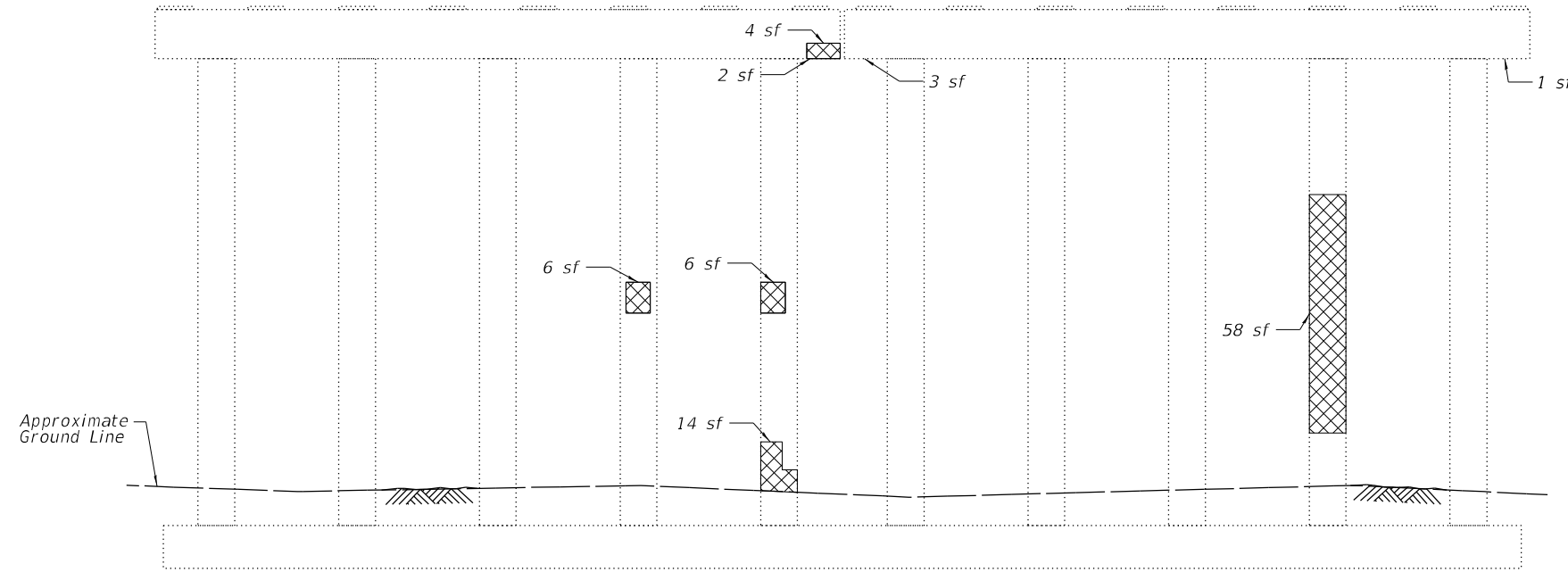
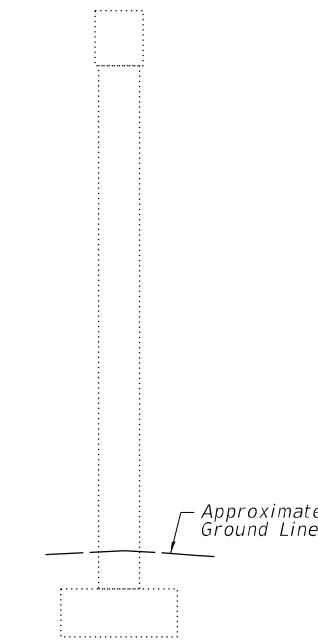
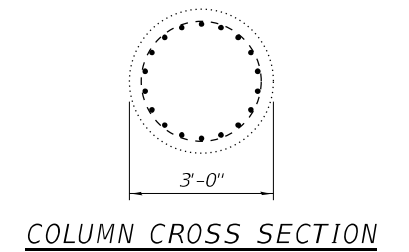
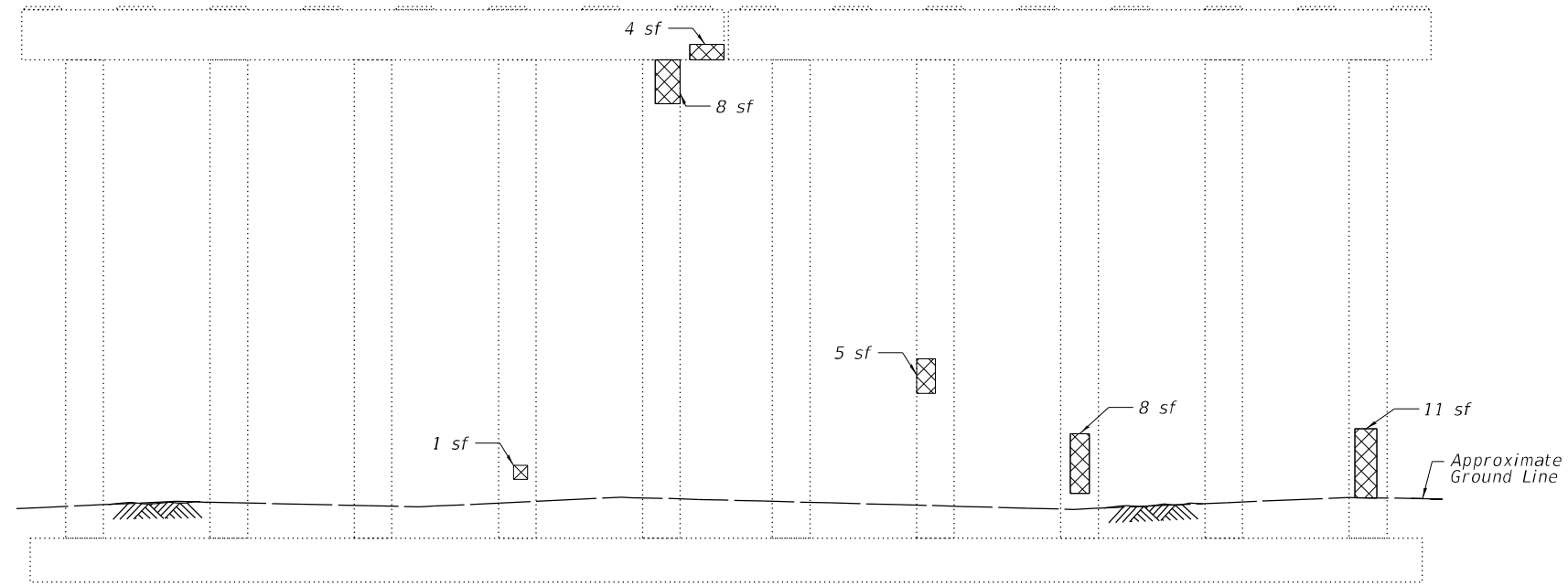
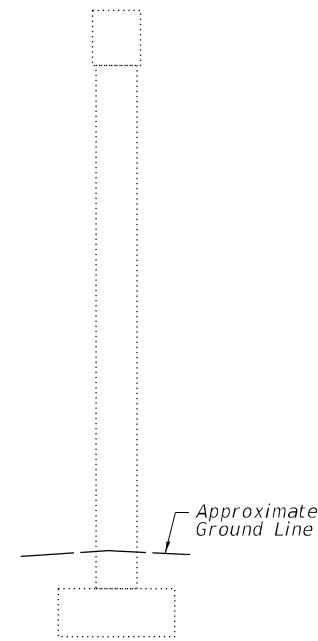
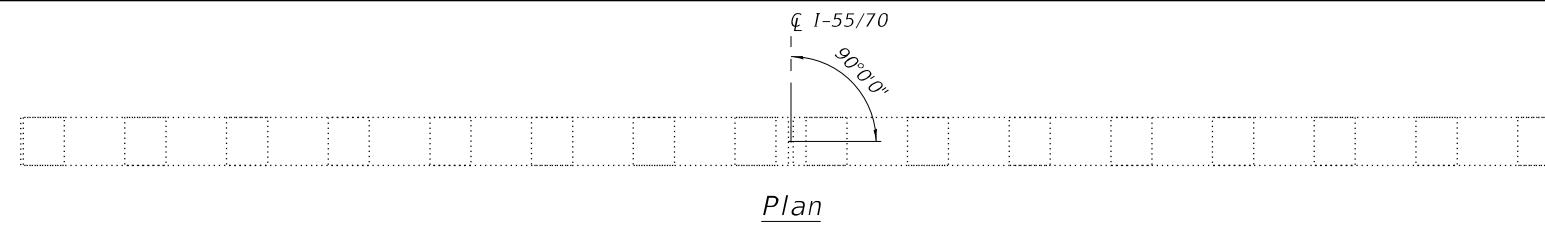

Structural Repair of Concrete

Notes:
 Repairs may be visible in multiple views, however, the repair is only shown in the most descriptive view.
 Repair locations and quantities shown on Plan or Elevation are approximate and based on the 2020 inspection findings. Allowance of 14 sf has been included in Bill of Material to account for uncertainty between 2020 inspection findings and present conditions.
 During demolition, it is possible that some repairs may extend below the existing grade.
 It is anticipated that the majority of repairs will be to a depth equal to or less than 5 inches. Some nominal quantity of repair depth greater than 5 inches has been assumed.
 Resident Engineer to verify all repair locations.

BILL OF MATERIAL

ITEM	UNIT	QUANTITY
Structural Repair of Concrete (Depth Equal to or Less Than 5 Inches)	Sq Ft	130
Structural Repair of Concrete (Depth Greater Than 5 Inches)	Sq Ft	15

MODEL: Default
 FILE NAME: Z:\15052.29 B&O RR Bridge\DCN\Bridg\final\Plotsheets\0820017-76K02-079-Rler 11.dgn

WJE ENGINEERS ARCHITECTS MATERIAL SCIENTISTS
 Wss, Janney, Elstner Associates, Inc.
 330 Pfingsten Road
 Northbrook, Illinois 60062
 847.272.7400 tel | 847.291.9595 fax
 www.wje.com

USER NAME = khill	DESIGNED - SMG	REVISED -
PLOT SCALE = 0.1667"/in.	CHECKED - RAW	REVISED -
PLOT DATE = 8/13/2024	DRAWN - SMG	REVISED -
	CHECKED - RAW	REVISED -

**STATE OF ILLINOIS
 DEPARTMENT OF TRANSPORTATION**

**PIER 11 REPAIR DETAILS
 STRUCTURE NO. 082-0017**

SHEET 79 OF 114 SHEETS

F.A.I. RTE.	SECTION	COUNTY	TOTAL SHEETS	SHEET NO.
55/70	82-5VB-R-2	ST. CLAIR	254	217
CONTRACT NO. 76K02				
ILLINOIS		FED. AID PROJECT		

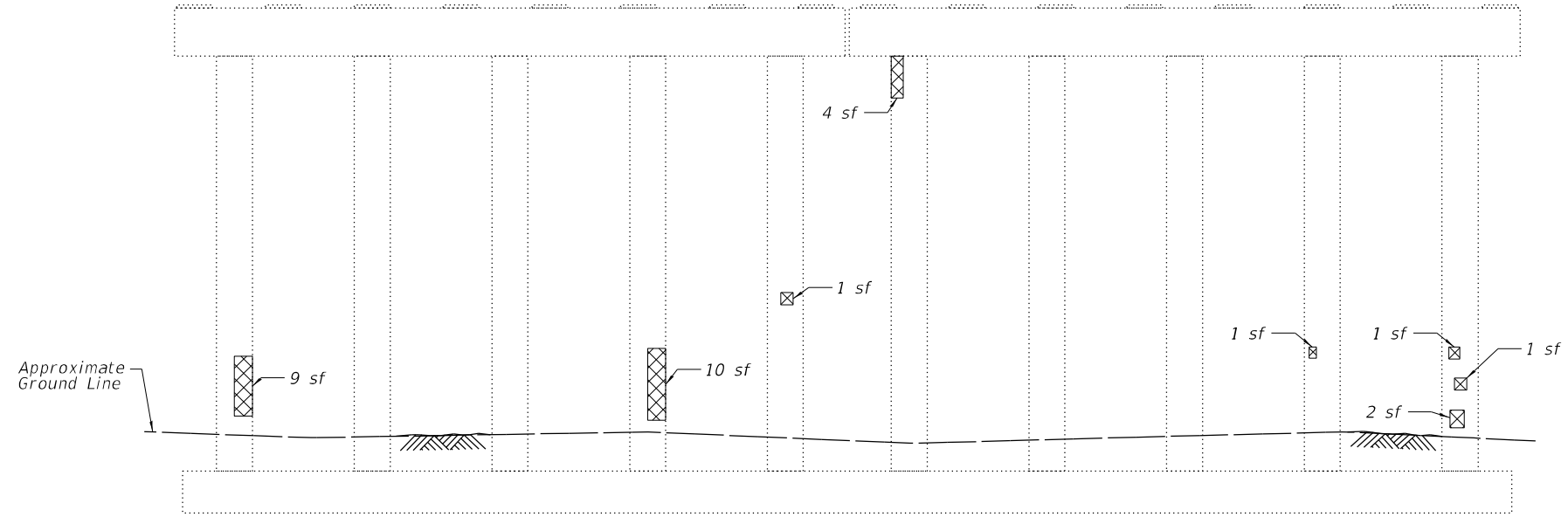
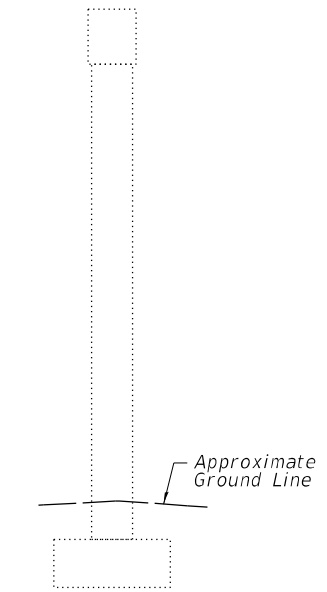
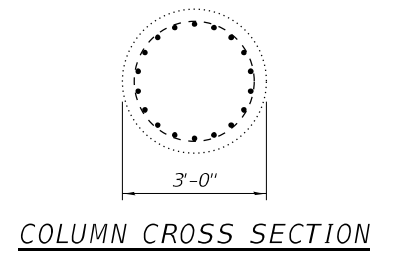
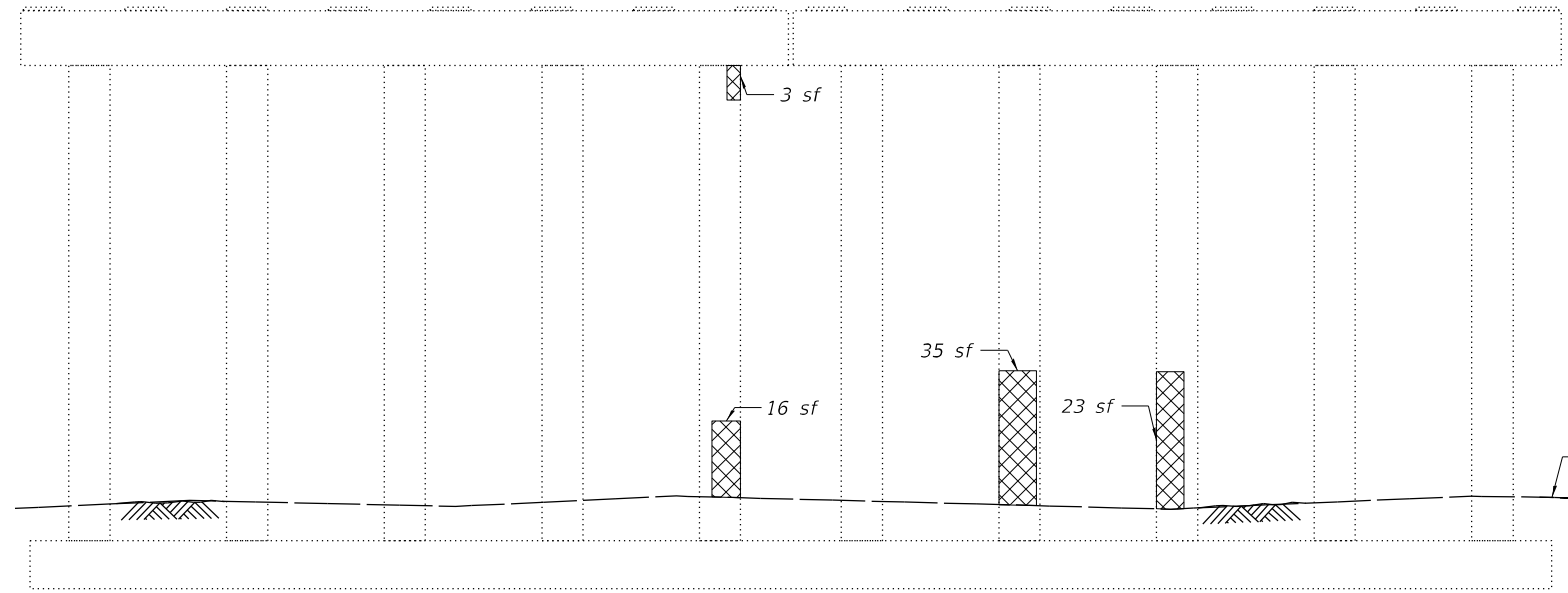
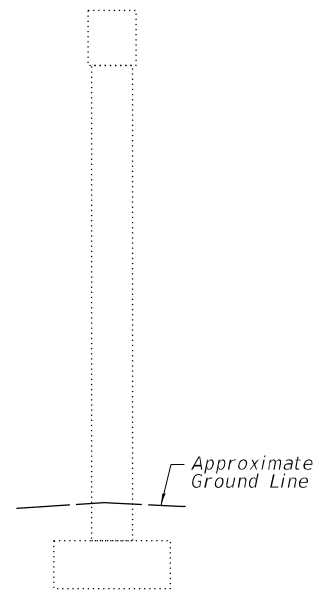
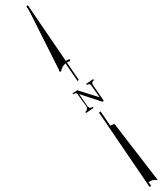
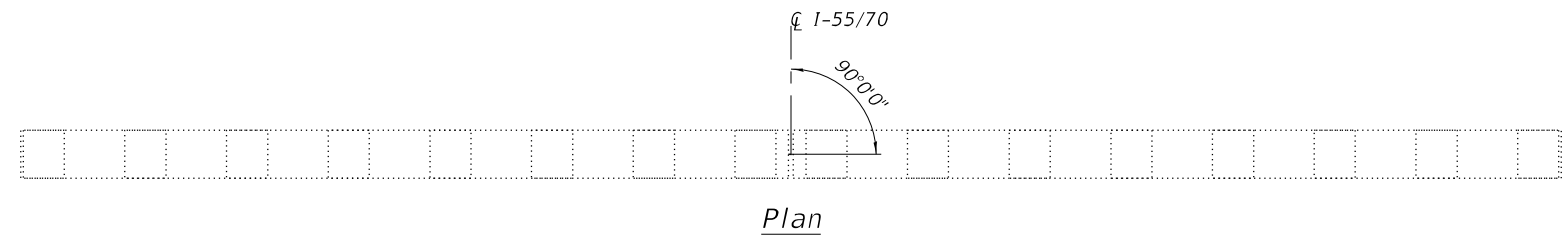

Structural Repair of Concrete

Notes:
 Repairs may be visible in multiple views, however, the repair is only shown in the most descriptive view.
 Repair locations and quantities shown on Plan or Elevation are approximate and based on the 2020 inspection findings. Allowance of 12 sf has been included in Bill of Material to account for uncertainty between 2020 inspection findings and present conditions.
 During demolition, it is possible that some repairs may extend below the existing grade.
 It is anticipated that the majority of repairs will be to a depth equal to or less than 5 inches. Some nominal quantity of repair depth greater than 5 inches has been assumed. Resident Engineer to verify all repair locations.

BILL OF MATERIAL

ITEM	UNIT	QUANTITY
Structural Repair of Concrete (Depth Equal to or Less Than 5 Inches)	Sq Ft	105
Structural Repair of Concrete (Depth Greater Than 5 Inches)	Sq Ft	13

MODEL: Default
 FILE NAME: Z:\1505229_B&O_RR_Bridge\DCN\Bridges\final\Plotsheets\0820017-76K02-080-Pier_12.dgn

WJE ENGINEERS ARCHITECTS MATERIAL SCIENTISTS
 Wss, Janney, Elstner Associates, Inc.
 330 Pfingsten Road
 Northbrook, Illinois 60062
 847.272.7400 tel | 847.291.9595 fax

USER NAME = khill	DESIGNED - SMG	REVISED -
PLOT SCALE = 0.1667"/in.	CHECKED - RAW	REVISED -
PLOT DATE = 8/13/2024	DRAWN - SMG	REVISED -
	CHECKED - RAW	REVISED -

**STATE OF ILLINOIS
 DEPARTMENT OF TRANSPORTATION**

**PIER 12 REPAIR DETAILS
 STRUCTURE NO. 082-0017**

SHEET 80 OF 114 SHEETS

F.A.I. RTE.	SECTION	COUNTY	TOTAL SHEETS	SHEET NO.
55/70	82-5VB-R-2	ST. CLAIR	254	218
CONTRACT NO. 76K02				
ILLINOIS		FED. AID PROJECT		

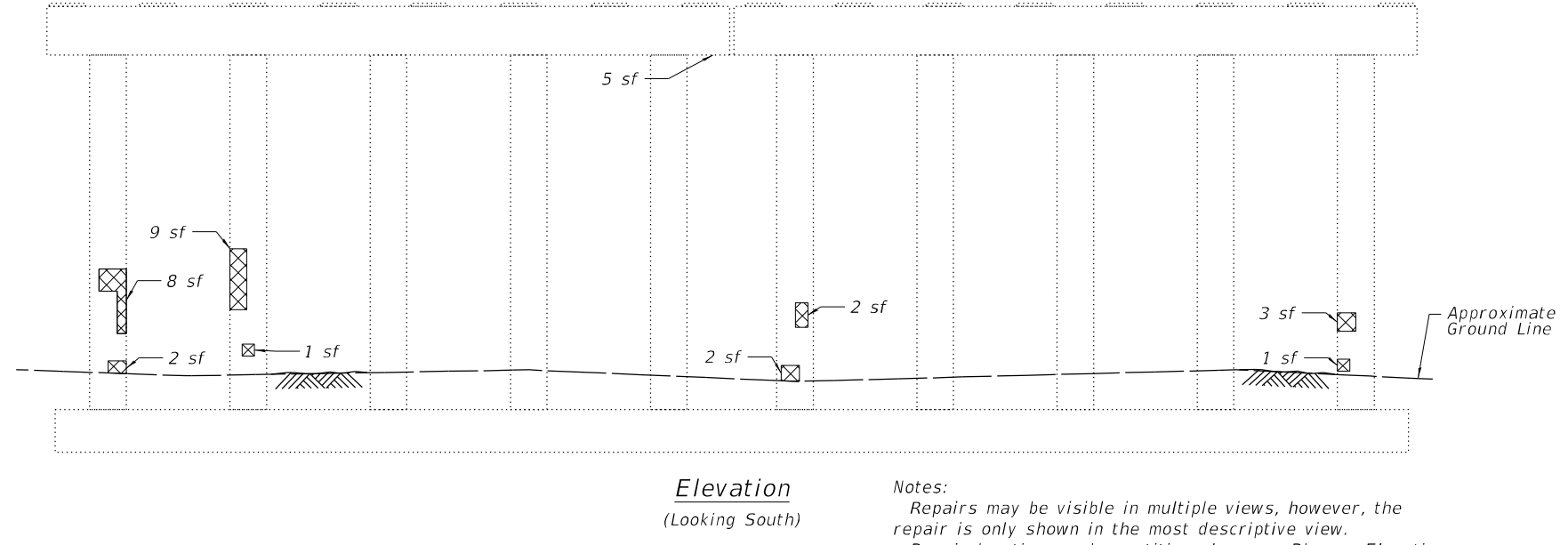
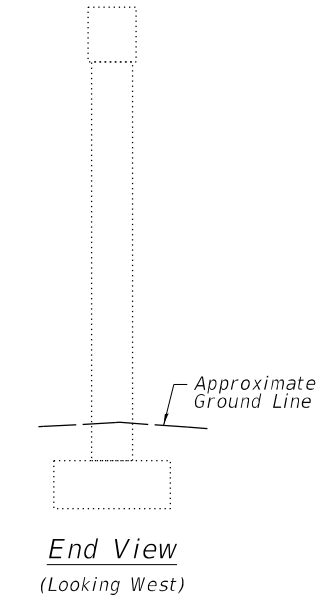
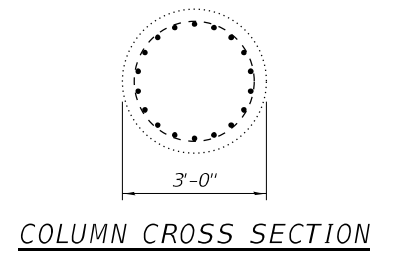
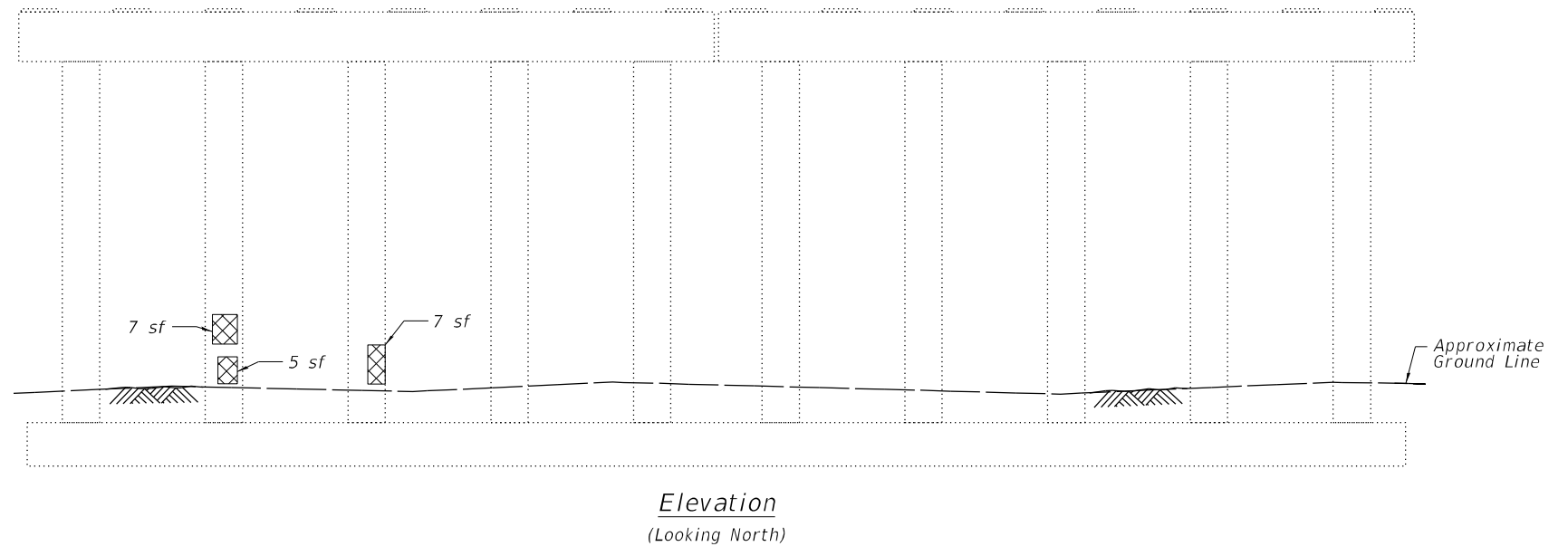
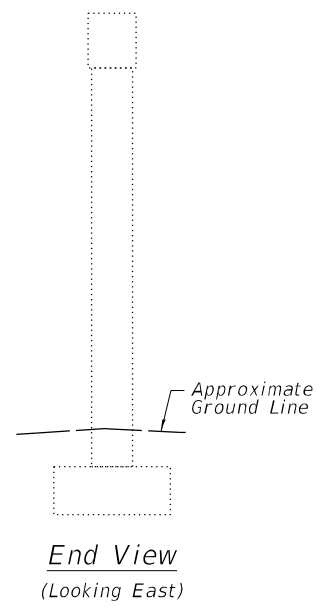
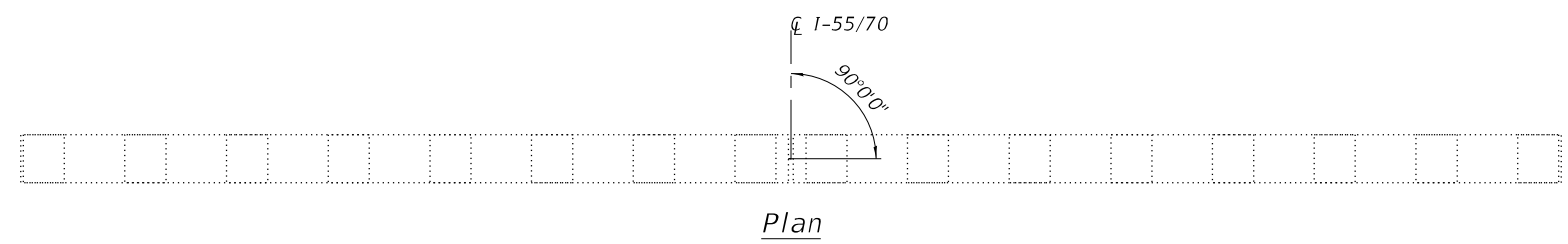

Structural Repair of Concrete

Notes:
 Repairs may be visible in multiple views, however, the repair is only shown in the most descriptive view.
 Repair locations and quantities shown on Plan or Elevation are approximate and based on the 2020 inspection findings. Allowance of 6 sf has been included in Bill of Material to account for uncertainty between 2020 inspection findings and present conditions.
 During demolition, it is possible that some repairs may extend below the existing grade.
 It is anticipated that the majority of repairs will be to a depth equal to or less than 5 inches. Some nominal quantity of repair depth greater than 5 inches has been assumed. Resident Engineer to verify all repair locations.

BILL OF MATERIAL

ITEM	UNIT	QUANTITY
Structural Repair of Concrete (Depth Equal to or Less Than 5 Inches)	Sq Ft	52
Structural Repair of Concrete (Depth Greater Than 5 Inches)	Sq Ft	6

MODEL: Default
 FILE NAME: Z:\15052.29 B&O RR Bridge\DCN\Bridg\final\Plotsheets\0820017-76K02-081-Pier_14.dgn
 8/13/2024 9:42:12 AM

WJE ENGINEERS ARCHITECTS MATERIAL SCIENTISTS Wss, Janney, Elstner Associates, Inc. 330 Pfingsten Road Northbrook, Illinois 60062 847.272.7400 tel 847.291.9595 fax www.wje.com	USER NAME = khill	DESIGNED - SMG	REVISED -
	PLOT SCALE = 0.1667"/in.	CHECKED - RAW	REVISED -
	PLOT DATE = 8/13/2024	DRAWN - SMG	REVISED -
		CHECKED - RAW	REVISED -

**STATE OF ILLINOIS
 DEPARTMENT OF TRANSPORTATION**

**PIER 14 REPAIR DETAILS
 STRUCTURE NO. 082-0017**

SHEET 81 OF 114 SHEETS

F.A.I. RTE.	SECTION	COUNTY	TOTAL SHEETS	SHEET NO.
55/70	82-5VB-R-2	ST. CLAIR	254	219
CONTRACT NO. 76K02				
		ILLINOIS	FED. AID PROJECT	

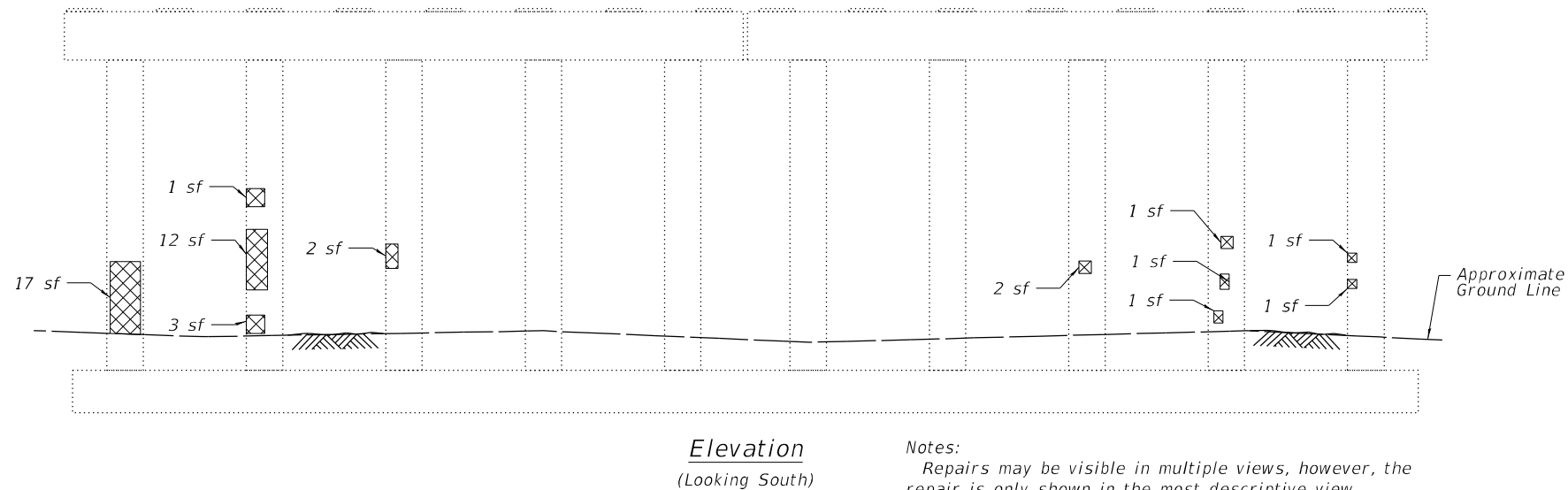
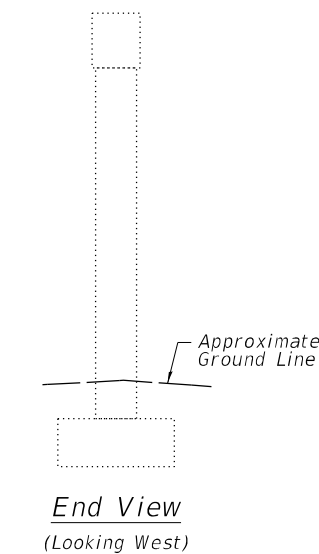
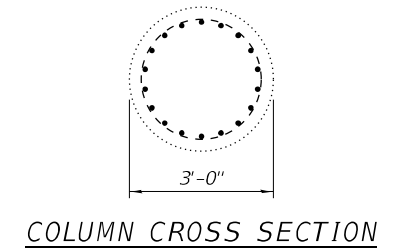
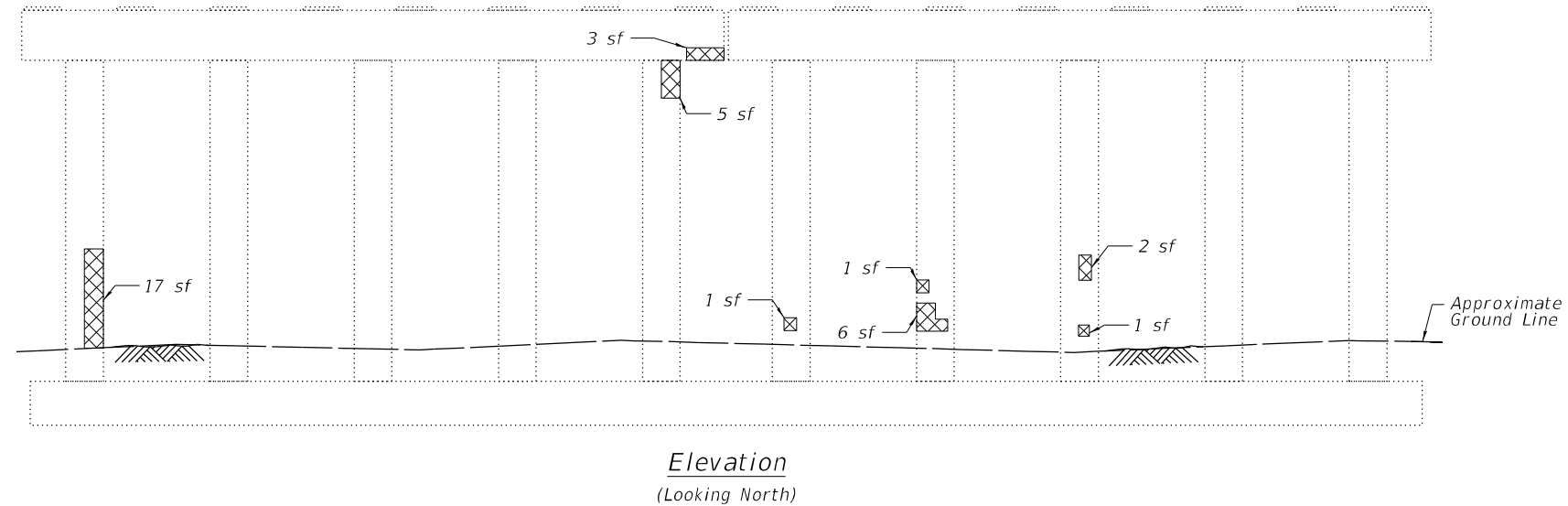
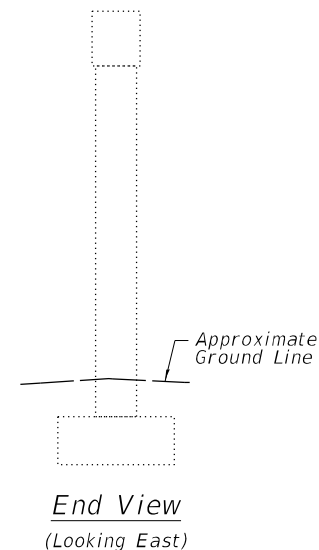
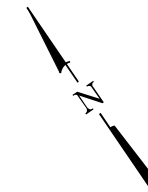
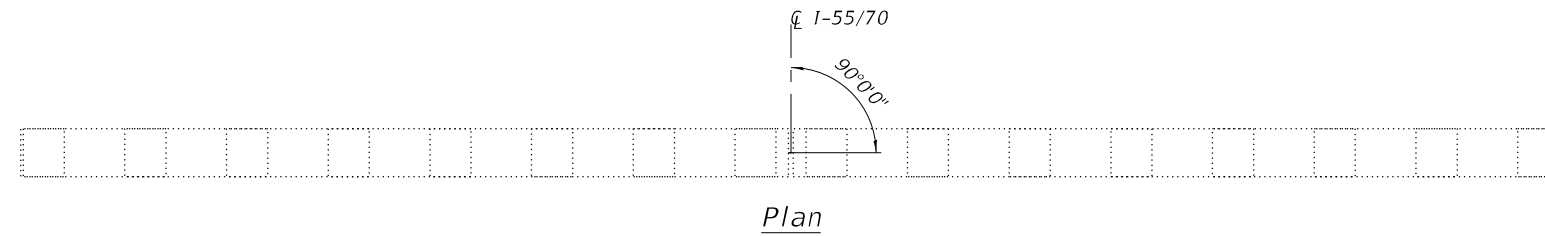

Structural Repair of Concrete

Notes:
 Repairs may be visible in multiple views, however, the repair is only shown in the most descriptive view.
 Repair locations and quantities shown on Plan or Elevation are approximate and based on the 2020 inspection findings. Allowance of 8 sf has been included in Bill of Material to account for uncertainty between 2020 inspection findings and present conditions.
 During demolition, it is possible that some repairs may extend below the existing grade.
 It is anticipated that the majority of repairs will be to a depth equal to or less than 5 inches. Some nominal quantity of repair depth greater than 5 inches has been assumed. Resident Engineer to verify all repair locations.

BILL OF MATERIAL

ITEM	UNIT	QUANTITY
Structural Repair of Concrete (Depth Equal to or Less Than 5 Inches)	Sq Ft	77
Structural Repair of Concrete (Depth Greater Than 5 Inches)	Sq Ft	9

MODEL: Default
 FILE NAME: Z:\15052.29 B&O RR Bridge\DCN\Bridg\final\Plotsheets\0820017-76K02-082-Pier 15.dgn

WJE ENGINEERS ARCHITECTS MATERIAL SCIENTISTS
 Wss, Janney, Elstner Associates, Inc.
 330 Pfingsten Road
 Northbrook, Illinois 60062
 847.272.7400 tel | 847.291.9595 fax

USER NAME = khill	DESIGNED - SMG	REVISED -
PLOT SCALE = 0.1667"/in.	CHECKED - RAW	REVISED -
PLOT DATE = 8/13/2024	DRAWN - SMG	REVISED -
	CHECKED - RAW	REVISED -

STATE OF ILLINOIS
 DEPARTMENT OF TRANSPORTATION

PIER 15 REPAIR DETAILS
 STRUCTURE NO. 082-0017

SHEET 82 OF 114 SHEETS

F.A.I. RTE.	SECTION	COUNTY	TOTAL SHEETS	SHEET NO.
55/70	82-5VB-R-2	ST. CLAIR	254	220
CONTRACT NO. 76K02				
		ILLINOIS	FED. AID PROJECT	

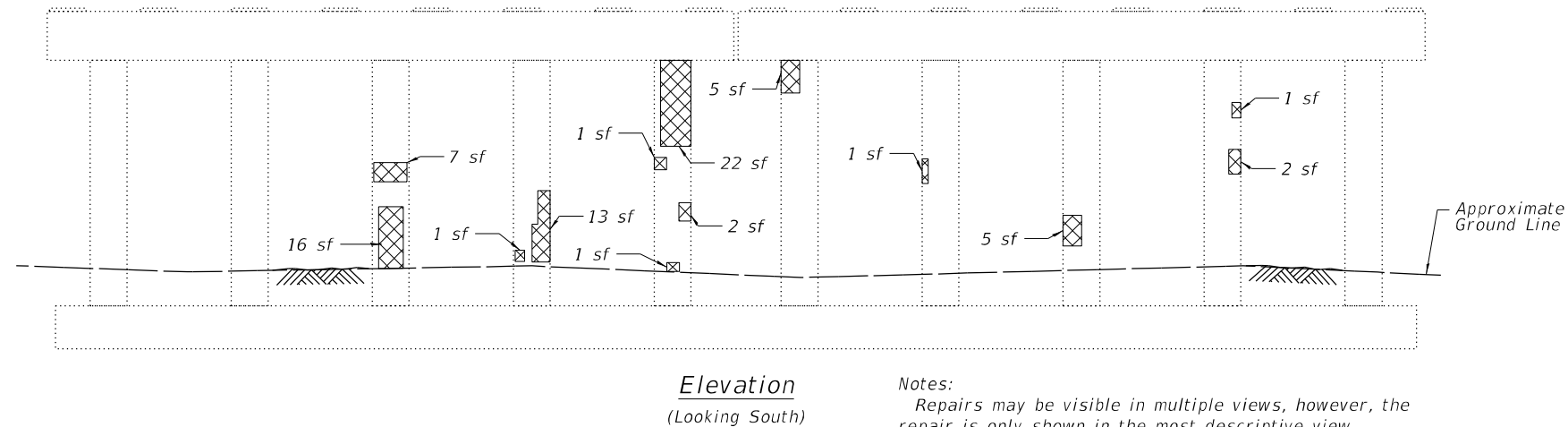
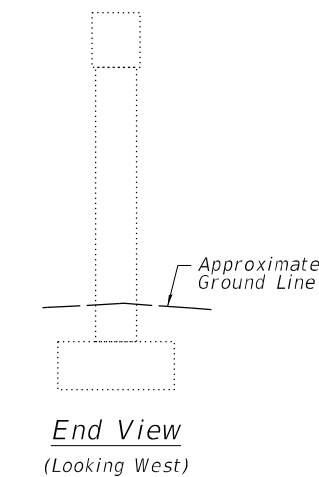
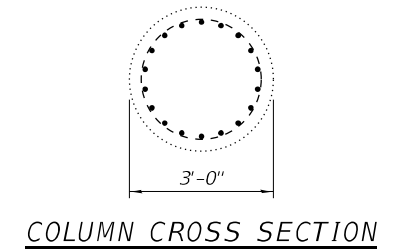
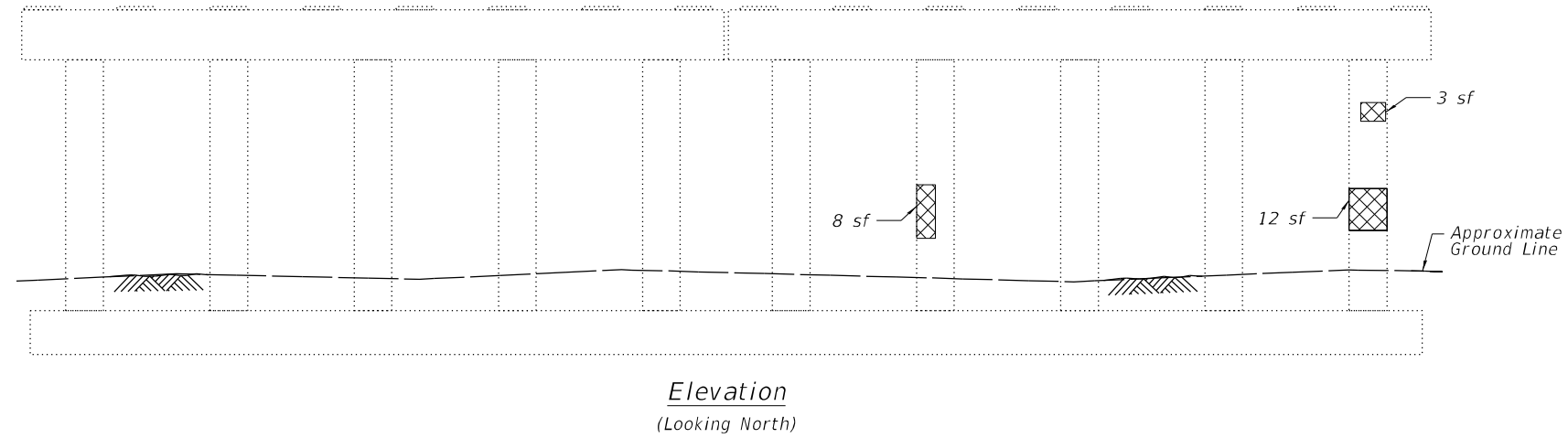
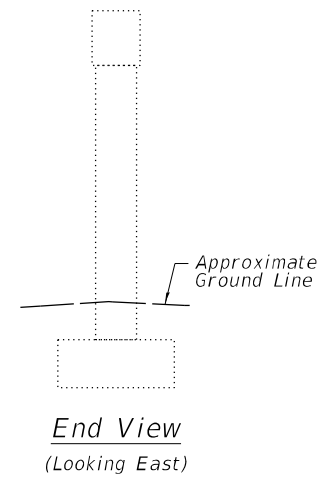
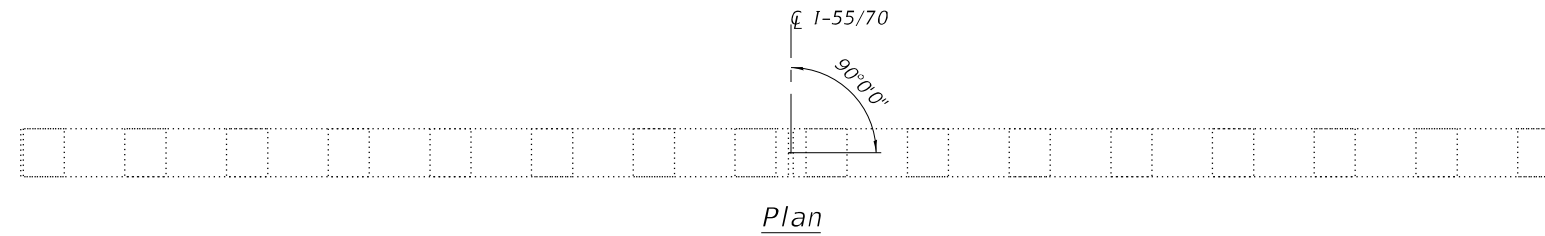

Structural Repair of Concrete

Notes:
 Repairs may be visible in multiple views, however, the repair is only shown in the most descriptive view.
 Repair locations and quantities shown on Plan or Elevation are approximate and based on the 2020 inspection findings. Allowance of 10 sf has been included in Bill of Material to account for uncertainty between 2020 inspection findings and present conditions.
 During demolition, it is possible that some repairs may extend below the existing grade.
 It is anticipated that the majority of repairs will be to a depth equal to or less than 5 inches. Some nominal quantity of repair depth greater than 5 inches has been assumed. Resident Engineer to verify all repair locations.

BILL OF MATERIAL

ITEM	UNIT	QUANTITY
Structural Repair of Concrete (Depth Equal to or Less Than 5 Inches)	Sq Ft	99
Structural Repair of Concrete (Depth Greater Than 5 Inches)	Sq Ft	11

MODEL: Default
 FILE NAME: Z:\1505229_B&O_RR_Bridge\DCN\Bridges\final\Plotsheets\0820017-76K02-083-Plr_17.dgn

WJE ENGINEERS ARCHITECTS MATERIAL SCIENTISTS
 Wss, Janney, Elstner Associates, Inc.
 330 Pfingsten Road
 Northbrook, Illinois 60062
 847.272.7400 tel | 847.291.9595 fax
 www.wje.com

USER NAME = khill	DESIGNED - SMG	REVISED -
PLOT SCALE = 0.1667"/in.	CHECKED - RAW	REVISED -
PLOT DATE = 8/13/2024	DRAWN - SMG	REVISED -
	CHECKED - RAW	REVISED -

**STATE OF ILLINOIS
 DEPARTMENT OF TRANSPORTATION**

**PIER 17 REPAIR DETAILS
 STRUCTURE NO. 082-0017**

SHEET 83 OF 114 SHEETS

F.A.I. RTE.	SECTION	COUNTY	TOTAL SHEETS	SHEET NO.
55/70	82-5VB-R-2	ST. CLAIR	254	221
CONTRACT NO. 76K02				
		ILLINOIS	FED. AID PROJECT	

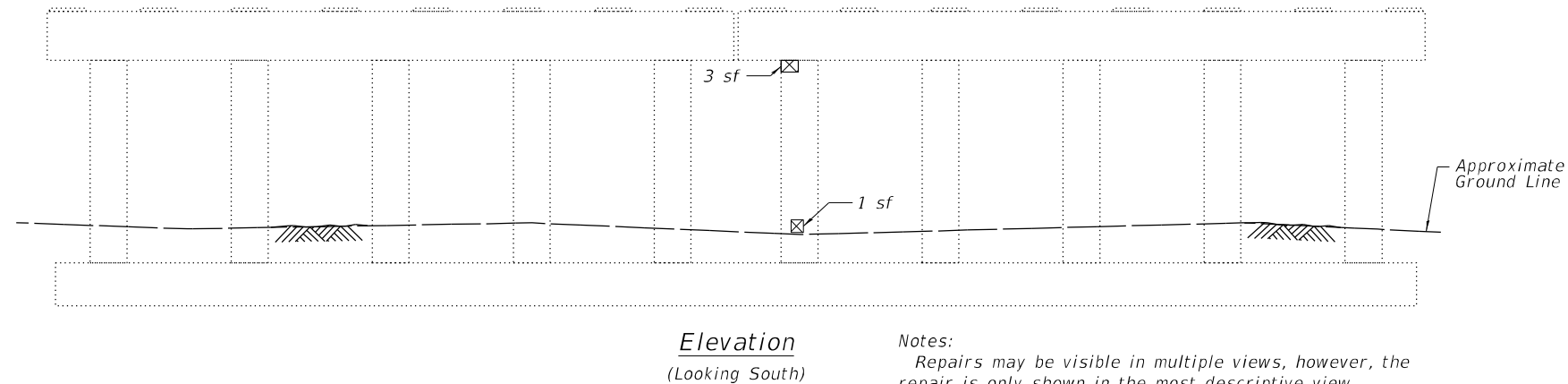
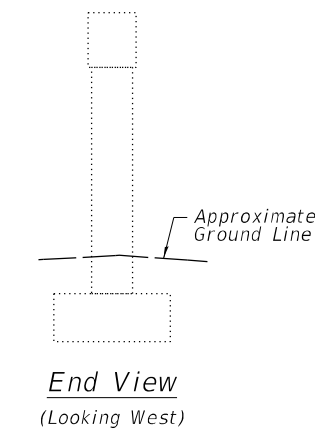
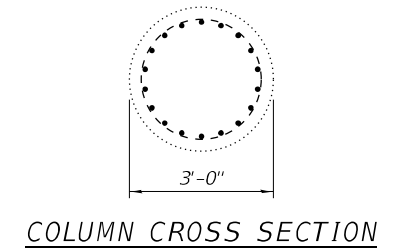
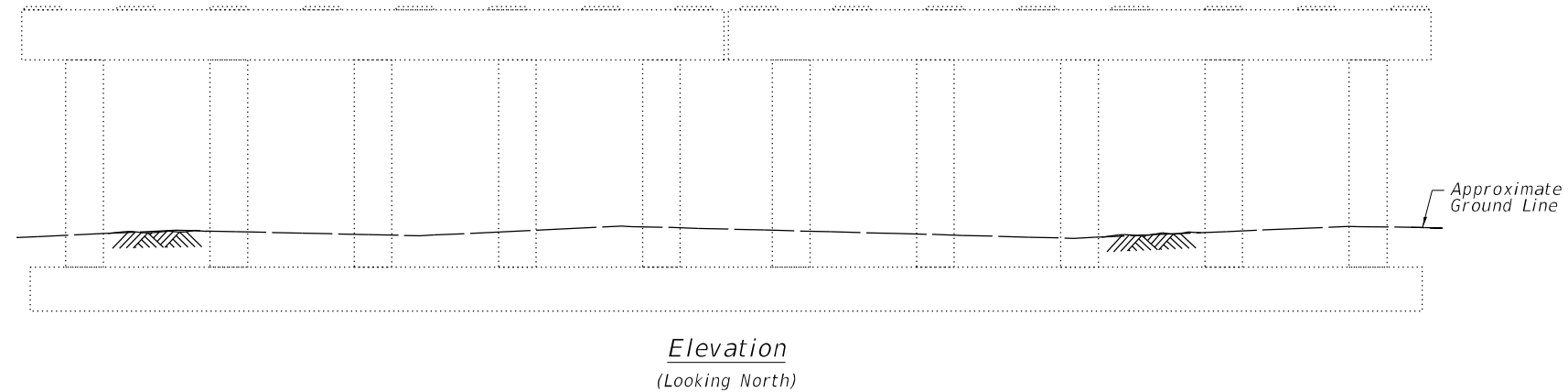
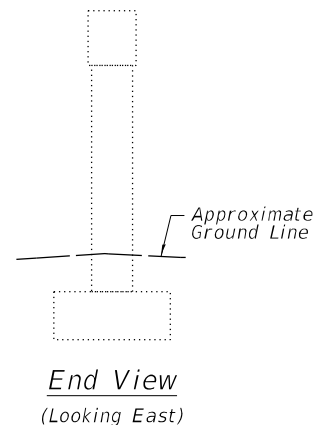
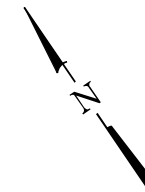
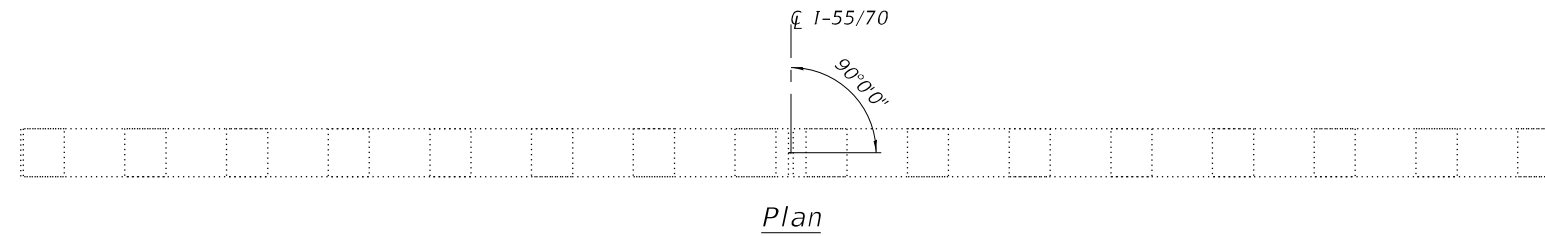

Structural Repair of Concrete

Notes:
 Repairs may be visible in multiple views, however, the repair is only shown in the most descriptive view.
 Repair locations and quantities shown on Plan or Elevation are approximate and based on the 2020 inspection findings. Allowance of 1 sf has been included in Bill of Material to account for uncertainty between 2020 inspection findings and present conditions.
 During demolition, it is possible that some repairs may extend below the existing grade.
 It is anticipated that the majority of repairs will be to a depth equal to or less than 5 inches. Some nominal quantity of repair depth greater than 5 inches has been assumed. Resident Engineer to verify all repair locations.

BILL OF MATERIAL

ITEM	UNIT	QUANTITY
Structural Repair of Concrete (Depth Equal to or Less Than 5 Inches)	Sq Ft	5
Structural Repair of Concrete (Depth Greater Than 5 Inches)	Sq Ft	0

MODEL: Default
FILE NAME: Z:\1505229_B&O_RR_Bridge\DCN\Bridges\final\Plotsheets\0820017-76K02-084-Pier_18.dgn

WJE ENGINEERS ARCHITECTS MATERIAL SCIENTISTS
 Wess, Janney, Elstner Associates, Inc.
 330 Pfingsten Road
 Northbrook, Illinois 60062
 847.272.7400 tel | 847.291.9595 fax
 www.wje.com

USER NAME = khill	DESIGNED - SMG	REVISED -
PLOT SCALE = 0.1667"/in.	CHECKED - RAW	REVISED -
PLOT DATE = 8/13/2024	DRAWN - SMG	REVISED -
	CHECKED - RAW	REVISED -

**STATE OF ILLINOIS
DEPARTMENT OF TRANSPORTATION**

**PIER 18 REPAIR DETAILS
STRUCTURE NO. 082-0017**

SHEET 84 OF 114 SHEETS

F.A.I. RTE.	SECTION	COUNTY	TOTAL SHEETS	SHEET NO.
55/70	82-5VB-R-2	ST. CLAIR	254	222
CONTRACT NO. 76K02				
		ILLINOIS	FED. AID PROJECT	

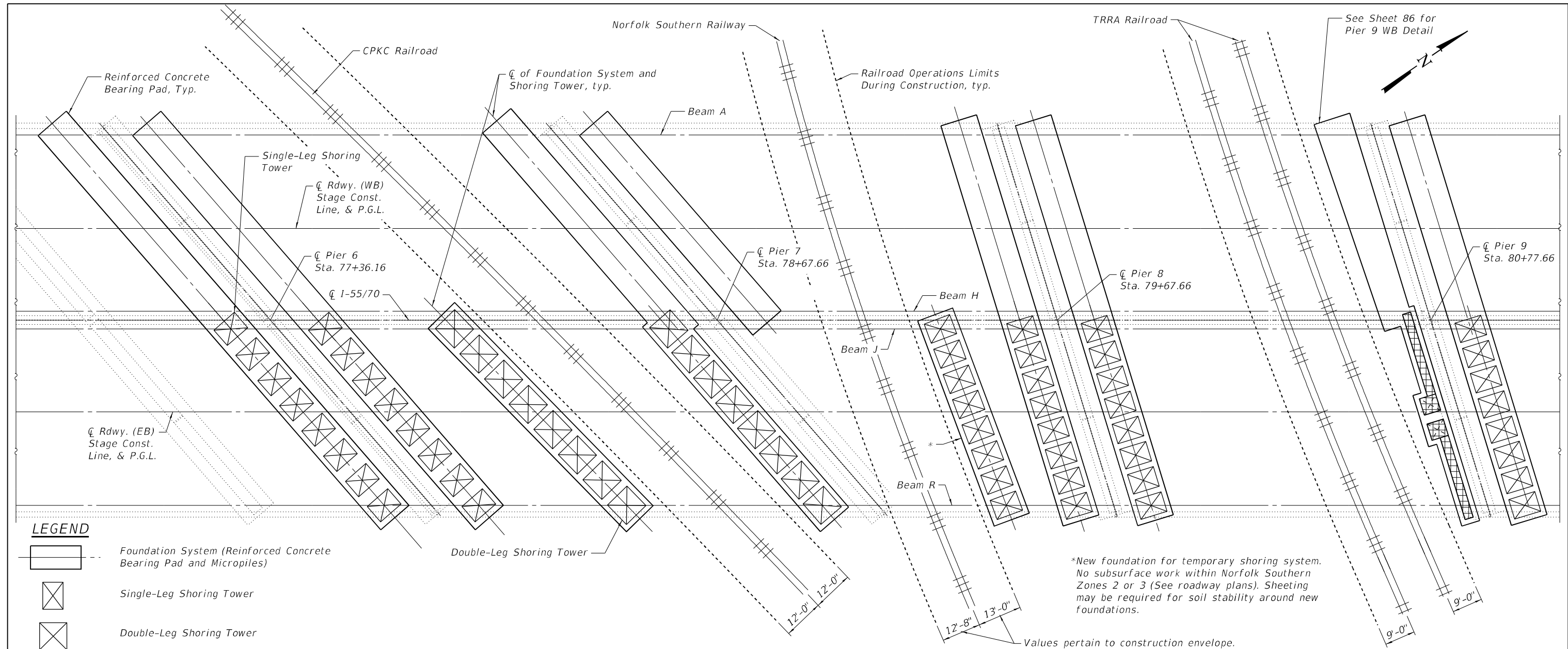

LEGEND

- Foundation System (Reinforced Concrete Bearing Pad and Micropiles)
- Single-Leg Shoring Tower
- Double-Leg Shoring Tower
- Prop Shoring Tower

(See Sheet 87 of 114 for additional information)

Notes:

1. No separate measurement and payment will be made for material needed to complete "Temporary Support System". Refer to Sheet 6 of 114 for typical reactions and locations. Refer to Sheet 97 of 114 for Pier 7 strongback reactions. Foundation systems shown for "Temporary Support System" include roughly 800 cu. yd. of structural concrete, 90,000 lbs of steel reinforcing bars, and a minimum of approximately 43,000 total linear feet of micropiles (with 600 individual micropiles). Components of strongback system include approximately 35,000 lbs of structural steel. Quantities are not included in the total project bill of materials.
2. Refer to Sheet 87 for micropile parameters and minimum requirements. Refer to Sheets 93 thru 96 for foundation details. Refer to Sheet 92 for shoring tower system details.
3. Plans show assumed placement of shoring tower systems for Eastbound work. Contractor may elect to replace Eastbound and Westbound at same time. Refer to Sheet 86 for shoring tower placement at interior fascia girders.
4. Pier 7 shall be replaced using "strongback" system shown on Sheets 97 thru 103 of 114. As noted on Sheet 100 of 114, steel superstructure repairs in Spans 7 and 8 shall be performed prior to temporary shoring operations.
5. Pier 9 Eastbound shall be replaced under staged construction loads, with foundation shown on Sheet 96. Contractor may elect to use conventional shoring system, and Contractor is responsible for coordination of subsurface activities adjacent to TRRA track.
6. Regardless of location of shoring tower, sheeting may be required for soil stability around all new foundations.
7. Refer to Roadway Notes for traffic control and staging requirements as related to installation and application of jacking loads.
8. Design and usage of Temporary Support System is specific to this Contract. After the Temporary Support System is no longer required, it shall be fully removed and become the property of the Contractor. All concrete bearing pads shall be removed, micropiles and deep foundations excavated to at least 3-ft below original grade, and the ground line at all locations, except Pier 9, shall be returned to its original condition once the temporary shoring is removed.

PARTIAL PLAN (SPANS 6 THRU 9)
(Eastbound shoring towers shown, See Note 3)

*New foundation for temporary shoring system. No subsurface work within Norfolk Southern Zones 2 or 3 (See roadway plans). Sheeting may be required for soil stability around new foundations.

Values pertain to construction envelope. Refer to roadway plans for subsurface restrictions.

MODEL: Default
FILE NAME: Z:\150522_29_B&O_RR_Bridge\Bridges\final\Plotsheets\0820017-76K02-085-Shoring_Plan_EB.dgn

WJE ENGINEERS ARCHITECTS MATERIAL SCIENTISTS
Wes, Janney, Elstner Associates, Inc.
330 Pfingsten Road
Northbrook, Illinois 60062
847.272.7400 tel | 847.291.9595 fax

USER NAME = khll	DESIGNED - SMG/JK	REVISED -
	CHECKED - AW/RAW	REVISED -
PLOT SCALE = 0.1667"/in.	DRAWN - ACG	REVISED -
PLOT DATE = 8/13/2024	CHECKED - SMG/RAW	REVISED -

**STATE OF ILLINOIS
DEPARTMENT OF TRANSPORTATION**

**PLAN VIEW OF SHORING NEAR RAILROADS
STRUCTURE NO. 082-0017**

SHEET 85 OF 114 SHEETS

F.A.I. RTE.	SECTION	COUNTY	TOTAL SHEETS	SHEET NO.
55/70	82-5VB-R-2	ST. CLAIR	254	223
CONTRACT NO. 76K02				
ILLINOIS FED. AID PROJECT				

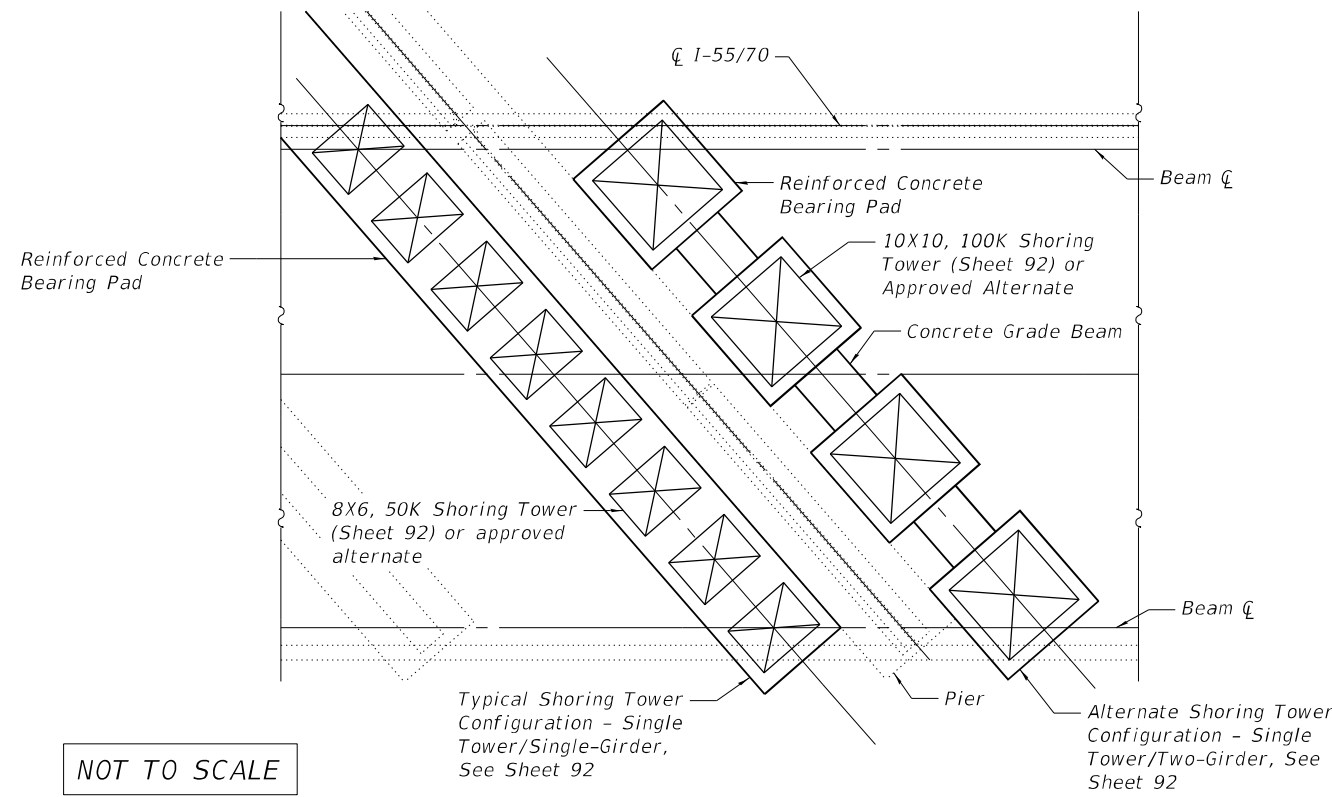

SHORING TOWER CONFIGURATIONS AT TYPICAL PIER

Note: Pier 6 shown. Refer to Sheet 85 for Layouts.

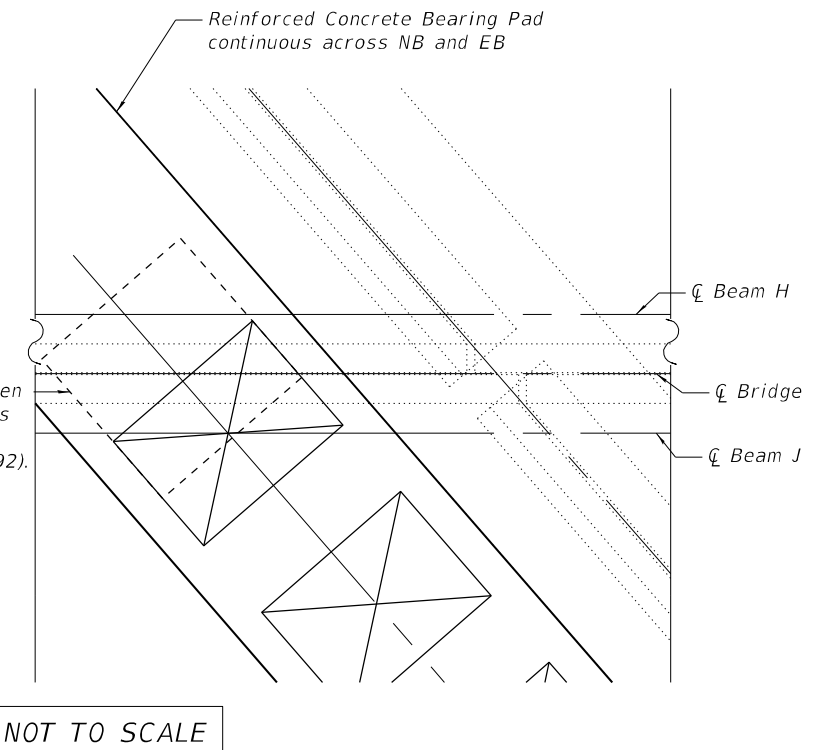

SHORING TOWER CONFIGURATIONS AT MEDIAN

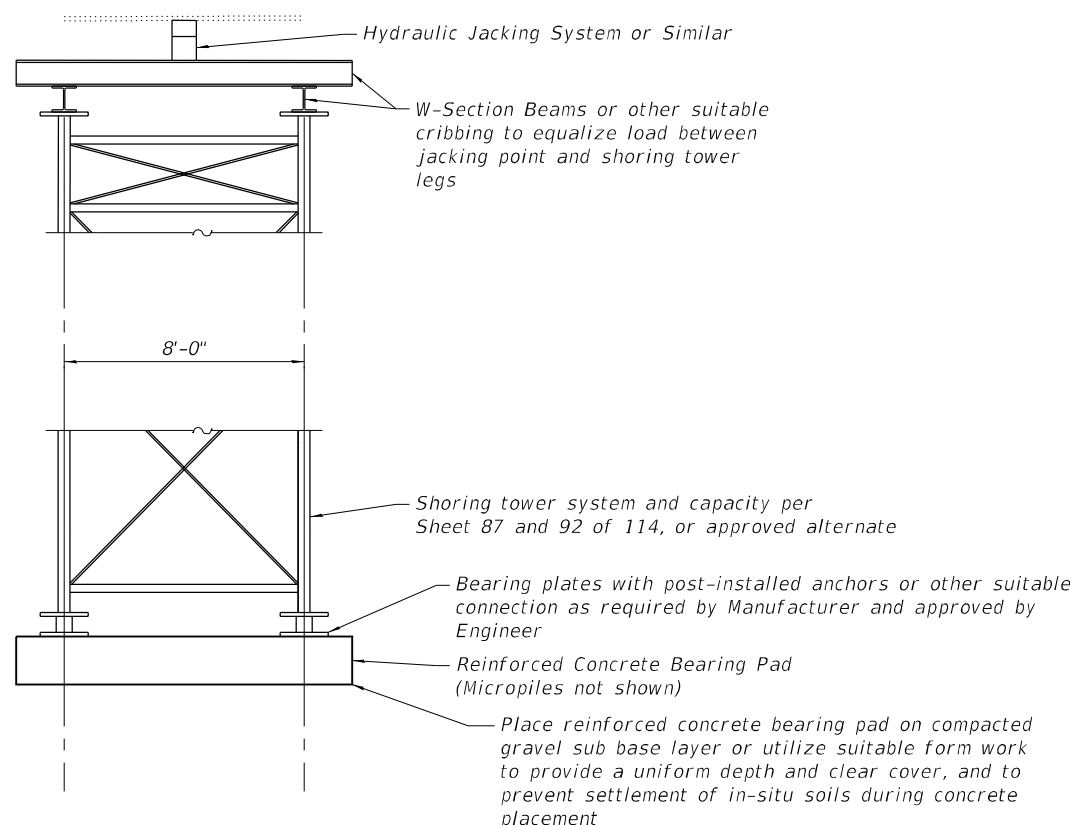

ELEVATION VIEW OF TYPICAL SHORING TOWER JACKING POINT

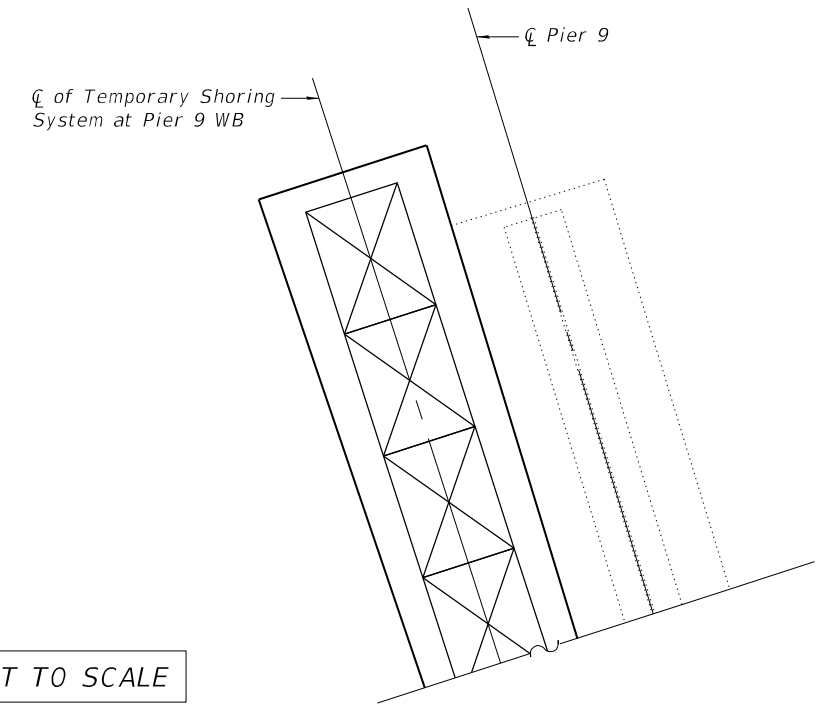

SHORING TOWER CONFIGURATION FOR PIER 9 WB - WEST BEARING

Micropile schedule shown on Sheet 87 assumes two micropiles per girder reaction, and shoring tower oriented as shown

MODEL: Default
FILE NAME: Z:\1505229_B&O_RR_Bridge\DN\Bridges\final\Plotsheets\0820017-76K02-086-Typical Shoring Tower Plans.dgn

WJE ENGINEERS ARCHITECTS MATERIAL SCIENTISTS
 Wss, Janney, Elstner Associates, Inc.
 330 Pfingsten Road
 Northbrook, Illinois 60062
 847.272.7400 tel | 847.291.9595 fax
 www.wje.com

USER NAME = khill	DESIGNED - SMG/JK	REVISED -
PLOT SCALE = 0.1667"/in.	CHECKED - AW/RAW	REVISED -
PLOT DATE = 8/13/2024	DRAWN - ACG	REVISED -
	CHECKED - SMG/RAW	REVISED -

**STATE OF ILLINOIS
DEPARTMENT OF TRANSPORTATION**

**TYPICAL SHORING TOWER PLANS
STRUCTURE NO. 082-0017**

SHEET 86 OF 114 SHEETS

F.A.I. RTE. 55/70	SECTION 82-5VB-R-2	COUNTY ST. CLAIR	TOTAL SHEETS 254	SHEET NO. 224
CONTRACT NO. 76K02				
		ILLINOIS	FED. AID PROJECT	

MICROPILE AND SHORING SYSTEM SCHEDULE

Pier	Traffic Direction	Bearing Reaction	Dimensions			Shoring Tower System [5]	Reinforced Concrete Bearing Pad Details
			Reaction Force (kips)	Micropile Length (ft) [3]	Approximate Micropile Spacing (ft) [4]		
6	EB & WB	West	76.6	55	3'-6"	EFCO 50K - Single Leg (200K)	Sheet 93
		East	160.1	60	3'-6"	EFCO 50K - Single Leg (200K)	Sheet 93
7	WB	West	164.2	60	3'-6"	EFCO 50K - Single Leg (200K)	Sheet 93
		East	152.4	60	3'-6"	EFCO 50K - Single Leg (200K)	Sheet 93
	EB [1]	Span 7 - Midspan	240.0	65	2'-5"	EFCO 50K - Double Leg (400K)	Sheet 94
		West	215.0	80	1'-7"	EFCO 50K - Double Leg (400K)	Sheet 94
8	EB & WB	Span 8 - Midspan	180.0	80	1'-9"	EFCO 50K - Single Leg (200K)	Sheet 94
		West	150.0	80	1'-9"	EFCO 50K - Single Leg (200K)	Sheet 93
9	EB	East	126.7	75	1'-9"	EFCO 50K - Single Leg (200K)	Sheet 93
		West [2]	70.3	65	2'-6"	Enkoflex by ULMA	Sheet 96
9	WB	East	127.1	90	1'-9"	EFCO 50K - Single Leg (200K)	Sheet 93
		West	128.0	85	[6]	EFCO 50K - Single Leg (200K)	Sheet 93 [6]
		East	127.1	90	1'-9"	EFCO 50K - Single Leg (200K)	Sheet 93

- [1] Strongback shoring system Sheet 94, and 97 thru 103 of 114
- [2] No construction Live Loads in Span 9 Eastbound
- [3] Micropile lengths shown are for foundation layouts shown on Sheet 85 of 114
- [4] Center to Center spacing between micropiles of adjacent shoring tower, as shown on Sheets 94 to 96 of 114
- [5] See Sheet 92 of 114 - alternates will be considered as part of shop drawing submittal and review
- [6] Shoring Tower configuration for Pier 9 WB utilizes towers rotated 90-degrees relative to typical installations. See Sheet 86 of 114

GENERAL NOTES

1. Shoring tower installation shall be approved by Manufacturer for project specific use.
2. Monitor existing foundations during construction to confirm no unintended settlement. Adjust final bearing heights to match original bottom flange elevations.
3. Load testing will show actual capacity of micropile. Notify Engineer if capacity determined during load test is less than design capacity.
4. Submit work plan for Engineer approval including all equipment to be used.
5. Submit as-built plans showing installed micropiles and final placement of concrete bearing pads.
6. Micropile locations may require adjustment to avoid intersection with buried utilities.
7. Casing shall extend through upper fill until depth of friction strata.
8. Casing - 7" O.D. x 5.000" API N.80 wall casing.
9. MP Reinforcement - #8 GR. 75 AG15 all threaded center bar.
10. Grout Strength - 4,000 PSI
11. Drilling Diameter - 8" dia. hole
12. Centralizers - Used at 1'-0" from top and bottom; 10'-0" intermediate spacing.
13. Reinforced concrete bearing pads shall be constructed with minimum compressive strength of 4,000 psi and Grade 60 reinforcement.

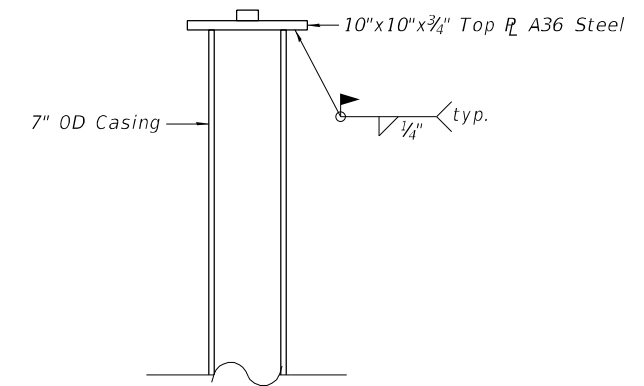

MICROPILE CAP PLATE DETAIL

MODEL: Default
FILE NAME: Z:\1505229_B&O_RR_Bridge\DCN\Bridges\final\Plotsheets\0820017-76K02-087-Micropile_Details_and_Notes.dgn

WJE ENGINEERS ARCHITECTS MATERIAL SCIENTISTS
 Wess, Janney, Elstner Associates, Inc.
 330 Pfingsten Road
 Northbrook, Illinois 60062
 847.272.7400 tel | 847.291.9595 fax
 www.wje.com

USER NAME = khill	DESIGNED - SMG/JK	REVISED -
PLOT SCALE = 0.1667" / in.	CHECKED - AW/RAW	REVISED -
PLOT DATE = 8/13/2024	DRAWN - ACG	REVISED -
	CHECKED - SMG/RAW	REVISED -

**STATE OF ILLINOIS
DEPARTMENT OF TRANSPORTATION**

**MICROPILE DETAILS AND NOTES
STRUCTURE NO. 082-0017**

SHEET 87 OF 114 SHEETS

F.A.I. RTE.	SECTION	COUNTY	TOTAL SHEETS	SHEET NO.
55/70	82-5VB-R-2	ST. CLAIR	254	225
CONTRACT NO. 76K02				
		ILLINOIS	FED. AID PROJECT	

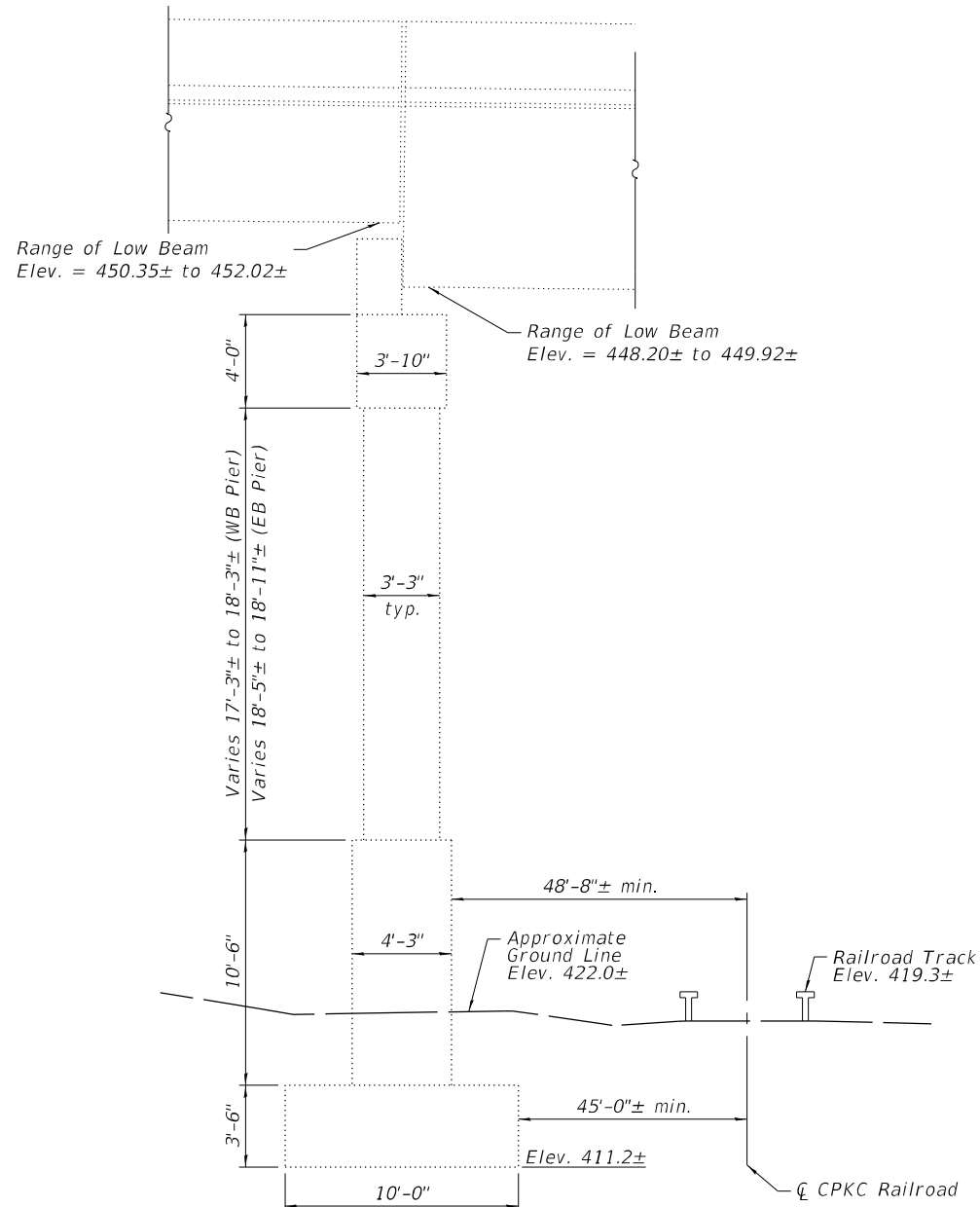

SECTION THRU PIER
(Looking West)

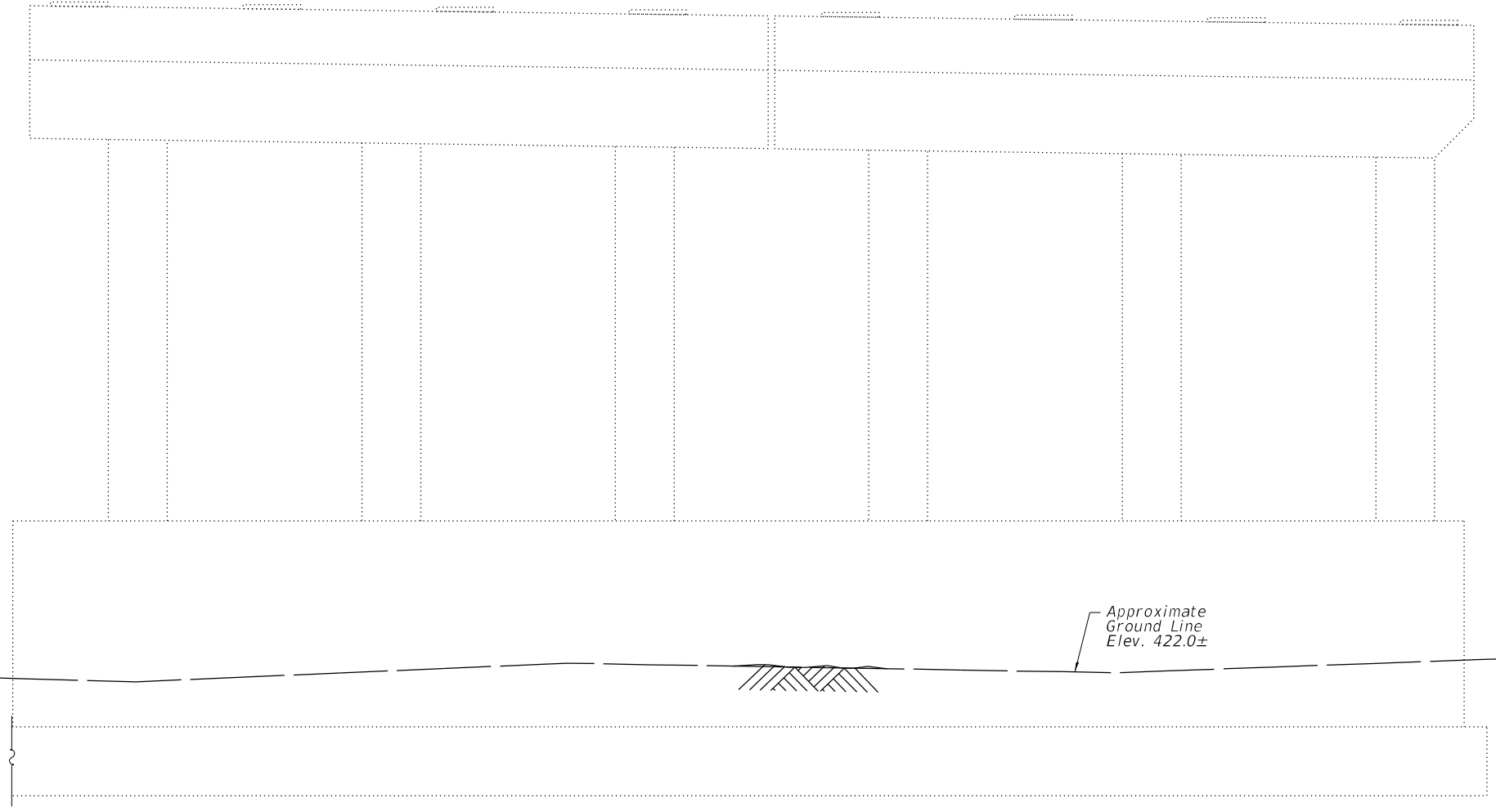

ELEVATION
(Looking North)
(Eastbound Structure Shown,
Westbound Structure Similiar)

Note:
Refer to Sheet 39 of 114 for removal extents.

MODEL: Default
FILE NAME: Z:\1505229_B&O_RR_Bridge\DCN\Bridges\0820017-76K02-088-Pier_6_Shoring.dgn

WJE ENGINEERS ARCHITECTS MATERIAL SCIENTISTS
Wiss, Janney, Elstner Associates, Inc.
330 Pfingsten Road
Northbrook, Illinois 60062
847.272.7400 tel | 847.291.9595 fax
www.wje.com

USER NAME = khill	DESIGNED - SMG/JK	REVISED -
PLOT SCALE = 0.1667"/in.	CHECKED - AW/RAW	REVISED -
PLOT DATE = 8/13/2024	DRAWN - ACB	REVISED -
	CHECKED - SMG/RAW	REVISED -

STATE OF ILLINOIS
DEPARTMENT OF TRANSPORTATION

PIER 6 DETAILS FOR SHORING DESIGN
STRUCTURE NO. 082-0017

SHEET 88 OF 114 SHEETS

F.A.I. RTE.	SECTION	COUNTY	TOTAL SHEETS	SHEET NO.
55/70	82-5VB-R-2	ST. CLAIR	254	226
CONTRACT NO. 76K02				
		ILLINOIS	FED. AID PROJECT	

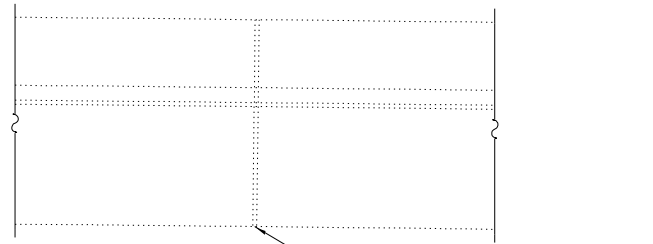

Range of Low Beam
Elev. = 450.07± to 450.76±

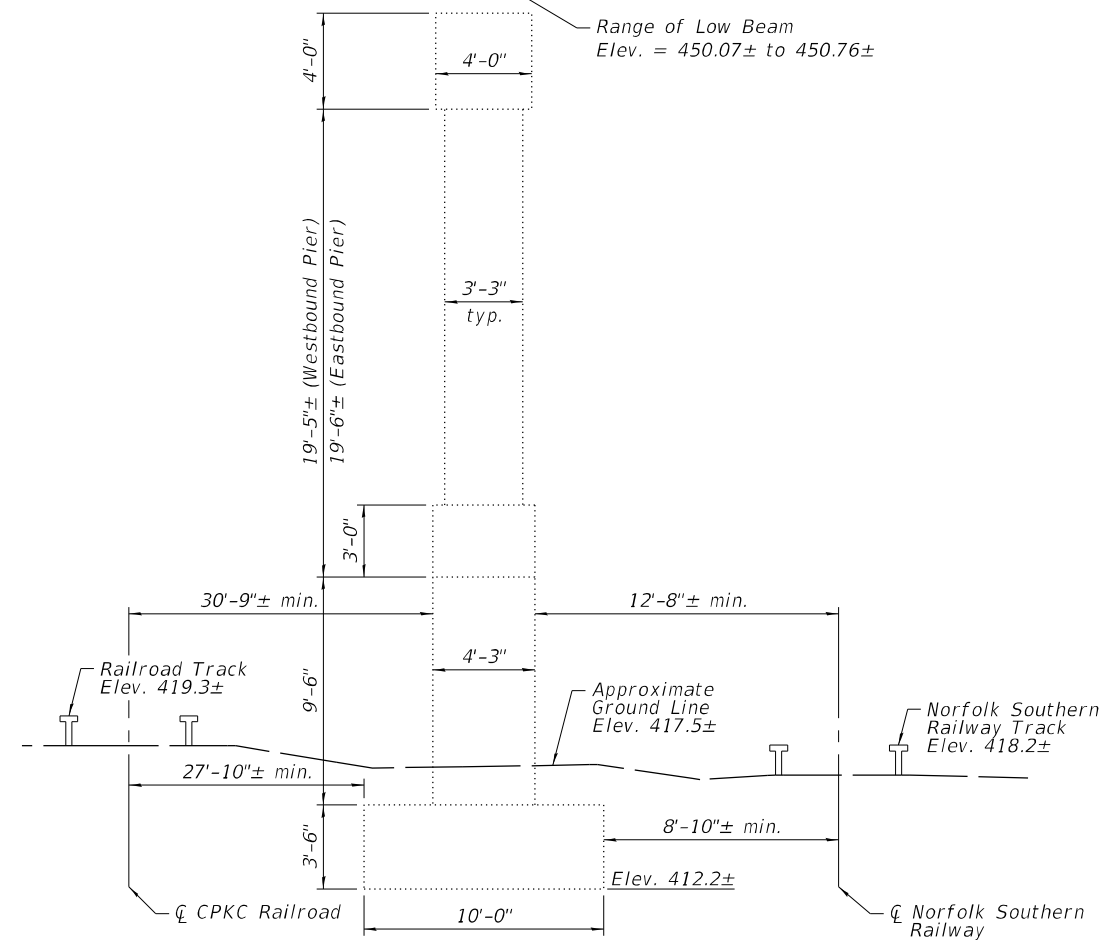

SECTION THRU PIER
(Looking West)

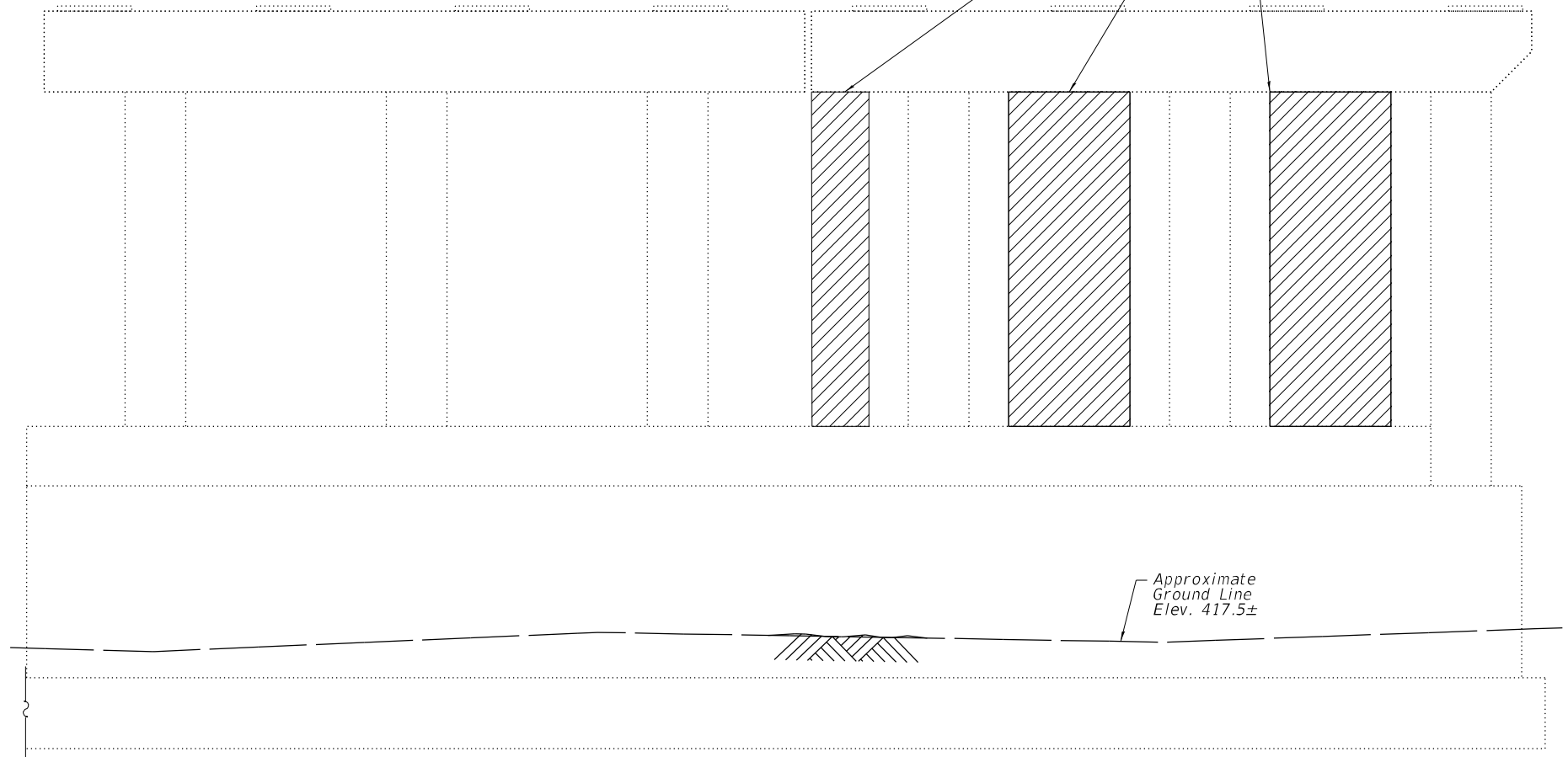

ELEVATION
(Looking North)
(Eastbound Structure Shown,
Westbound Structure Similiar)

Where partial/staged removal will occur,
temporary shoring system shall be
installed prior to transferring loading
and commencing demolition activities.
ALUPROP by ULMA or approved alternate.
Included in Temporary Support System,
Location 3.

Note:
Refer to Sheet 40 of 114 for removal extents.

MODEL: Default
FILE NAME: Z:\15052.29_B&O_RR_Bridge\DC\N\Bridg\final\Plotsheets\0820017-76K02-089-R-7_Shorings.dgn

WJE ENGINEERS ARCHITECTS MATERIAL SCIENTISTS
Wiss, Janney, Elstner Associates, Inc.
330 Pfingsten Road
Northbrook, Illinois 60062
847.272.7400 tel | 847.291.9595 fax
www.wje.com

USER NAME = khill	DESIGNED - SMG/JK	REVISED -
PLOT SCALE = 0.1667"/in.	CHECKED - AW/RAW	REVISED -
PLOT DATE = 8/13/2024	DRAWN - ACB	REVISED -
	CHECKED - SMG/RAW	REVISED -

**STATE OF ILLINOIS
DEPARTMENT OF TRANSPORTATION**

**PIER 7 DETAILS FOR SHORING DESIGN
STRUCTURE NO. 082-0017**

SHEET 89 OF 114 SHEETS

F.A.I. RTE.	SECTION	COUNTY	TOTAL SHEETS	SHEET NO.
55/70	82-5VB-R-2	ST. CLAIR	254	227
CONTRACT NO. 76K02				
		ILLINOIS	FED. AID PROJECT	

MODEL: Default
 FILE NAME: Z:\1505229_B&O_RR_Bridge\DCN\Bridges\0820017-76K02-090-Pier_8_Shoring.dgn

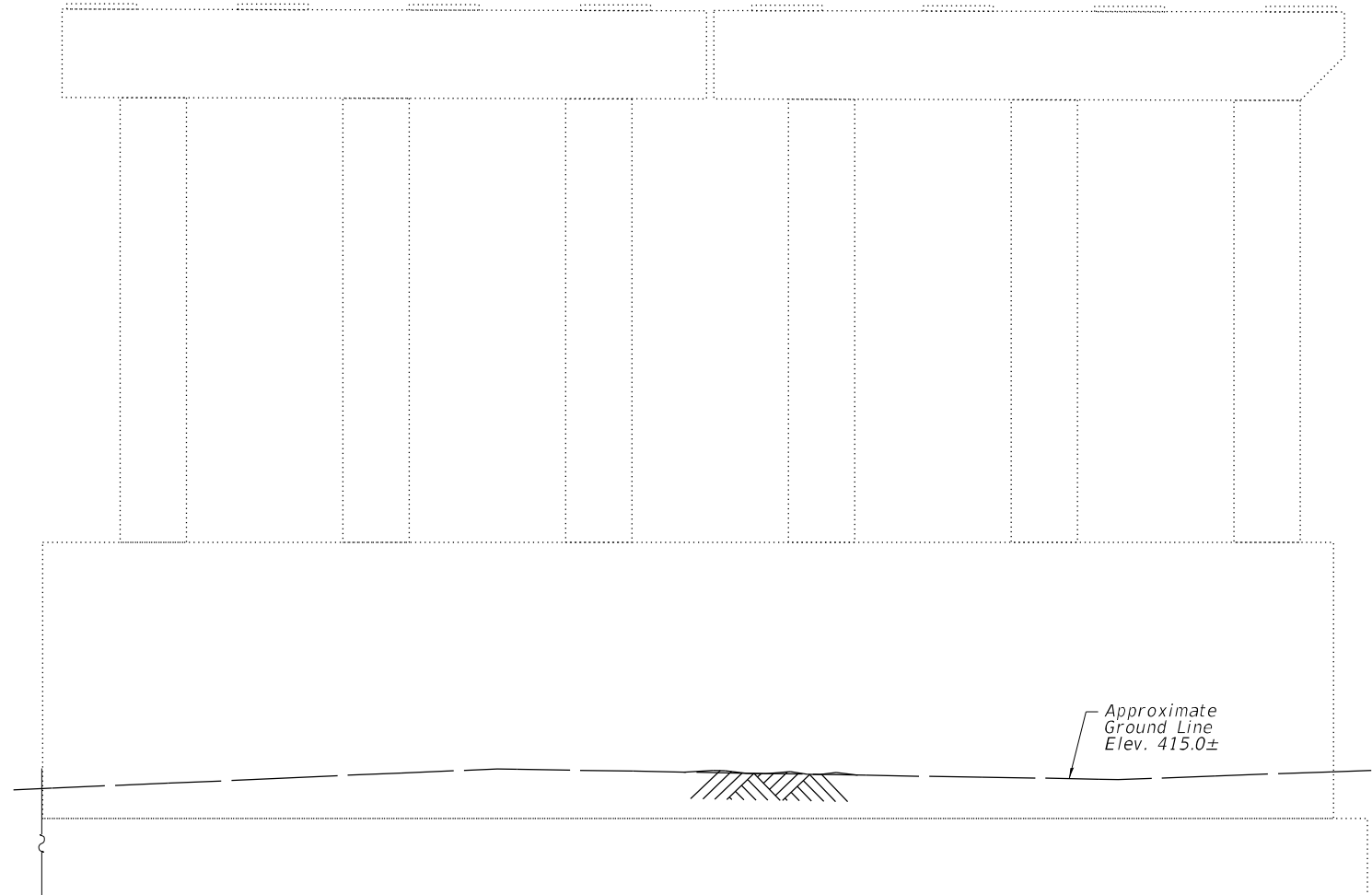
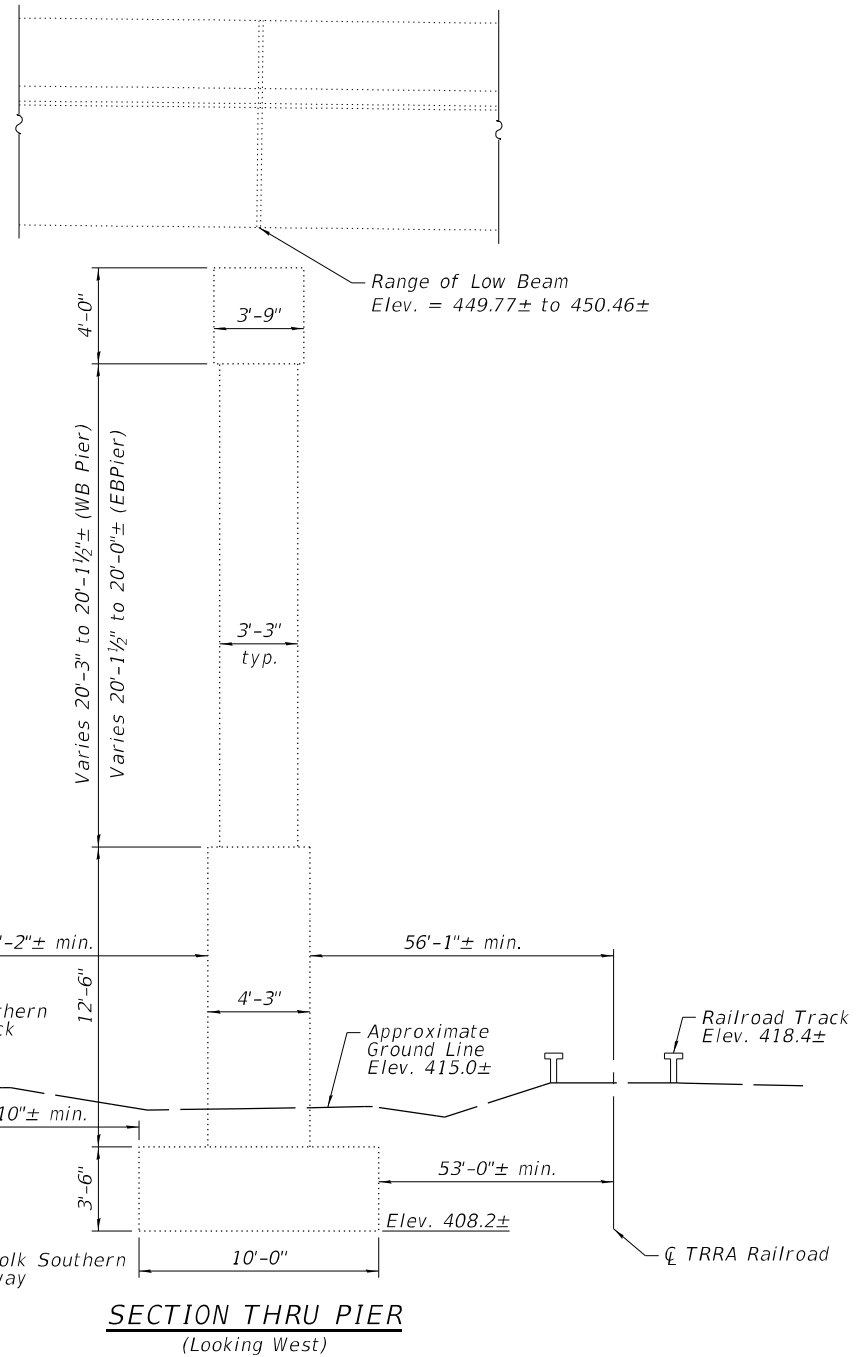

Note:
 Refer to Sheet 41 of 114 for removal extents.

WJE ENGINEERS ARCHITECTS MATERIAL SCIENTISTS
 Wss, Janney, Elstner Associates, Inc.
 330 Pfingsten Road
 Northbrook, Illinois 60062
 847.272.7400 tel | 847.291.9595 fax
 www.wje.com

USER NAME = khill	DESIGNED - SMG/JK	REVISED -
PLOT SCALE = 0.1667"/in.	CHECKED - AW/RAW	REVISED -
PLOT DATE = 8/13/2024	DRAWN - ACB	REVISED -
	CHECKED - SMG/RAW	REVISED -

STATE OF ILLINOIS
 DEPARTMENT OF TRANSPORTATION

PIER 8 DETAILS FOR SHORING DESIGN
 STRUCTURE NO. 082-0017

SHEET 90 OF 114 SHEETS

F.A.I. RTE.	SECTION	COUNTY	TOTAL SHEETS	SHEET NO.
55/70	82-5VB-R-2	ST. CLAIR	254	228
CONTRACT NO. 76K02				
ILLINOIS		FED. AID PROJECT		

MODEL: Default
 FILE NAME: Z:\15052.29_B&O_RR_Bridge\DC\N\Bridg\final\Plotsheets\0820017-76K02-091-Pier_9_Shoring.dgn

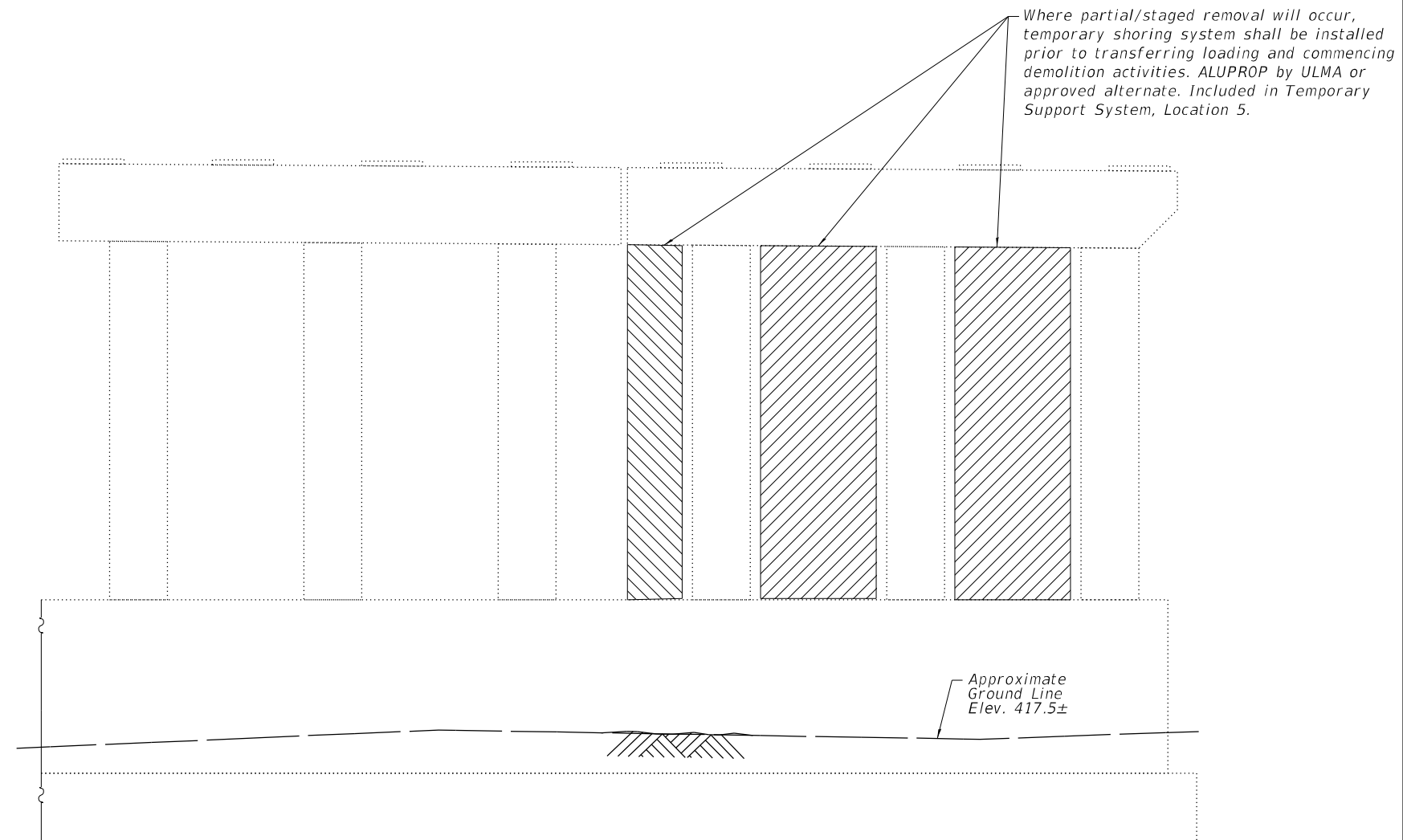
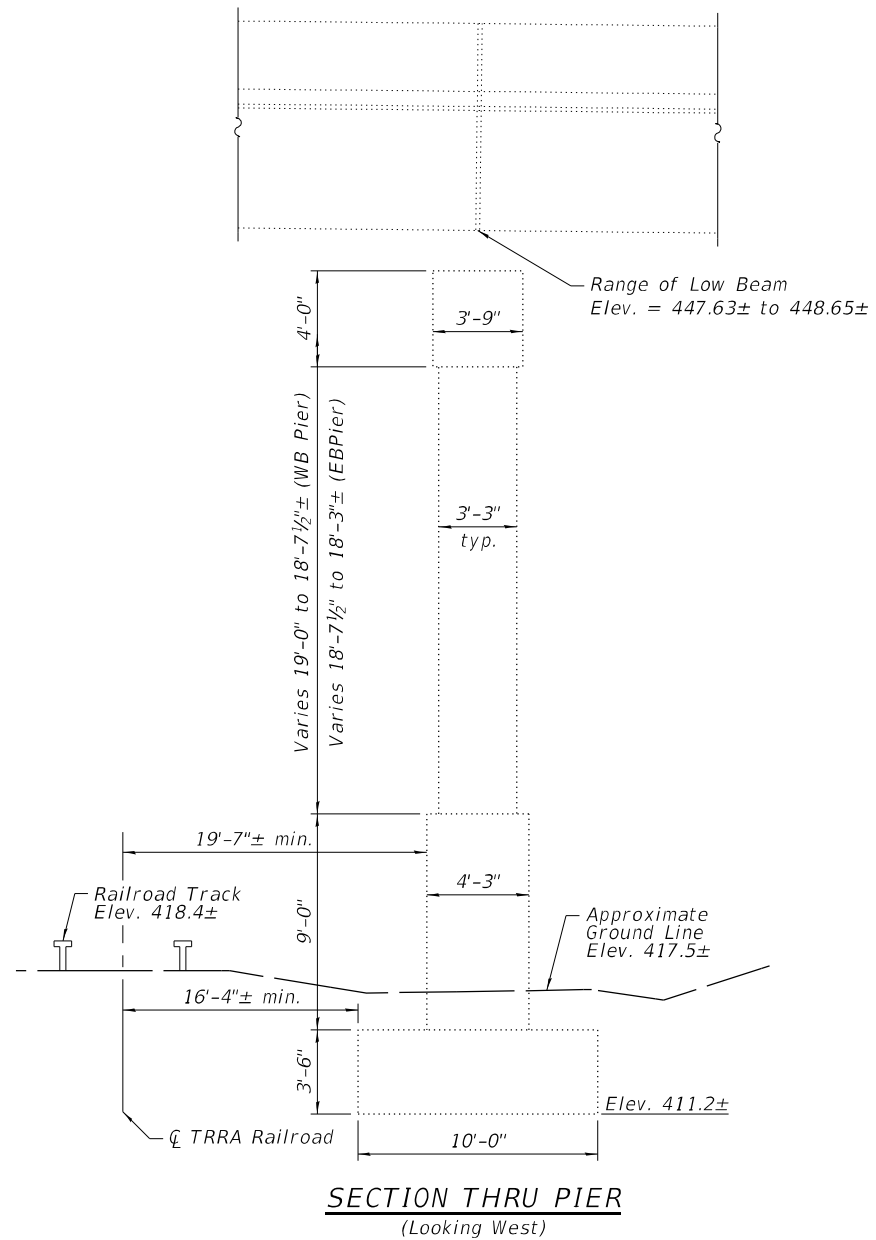

Where partial/staged removal will occur, temporary shoring system shall be installed prior to transferring loading and commencing demolition activities. ALUPROP by ULMA or approved alternate. Included in Temporary Support System, Location 5.

ELEVATION
 (Looking North)
 (Eastbound Structure Shown,
 Westbound Structure Similiar)

Note:
 Refer to Sheet 42 of 114 for removal extents.

WJE ENGINEERS ARCHITECTS MATERIAL SCIENTISTS
 Wess, Janney, Elstner Associates, Inc.
 330 Pfingsten Road
 Northbrook, Illinois 60062
 847.272.7400 tel | 847.291.9595 fax
 www.wje.com

USER NAME = khill	DESIGNED - SMG/JK	REVISED -
PLOT SCALE = 0.1667"/in.	CHECKED - AW/RAW	REVISED -
PLOT DATE = 8/13/2024	DRAWN - ACB	REVISED -
	CHECKED - SMG/RAW	REVISED -

STATE OF ILLINOIS
DEPARTMENT OF TRANSPORTATION

PIER 9 DETAILS FOR SHORING DESIGN
STRUCTURE NO. 082-0017

SHEET 91 OF 114 SHEETS

F.A.I. RTE. 55/70	SECTION 82-5VB-R-2	COUNTY ST. CLAIR	TOTAL SHEETS 254	SHEET NO. 229
CONTRACT NO. 76K02				
ILLINOIS		FED. AID PROJECT		

Heart of the System

Just because it's simple, doesn't mean it's not tough.

EXCERPT FROM EFCO 50K & 100K SHORING CATALOG

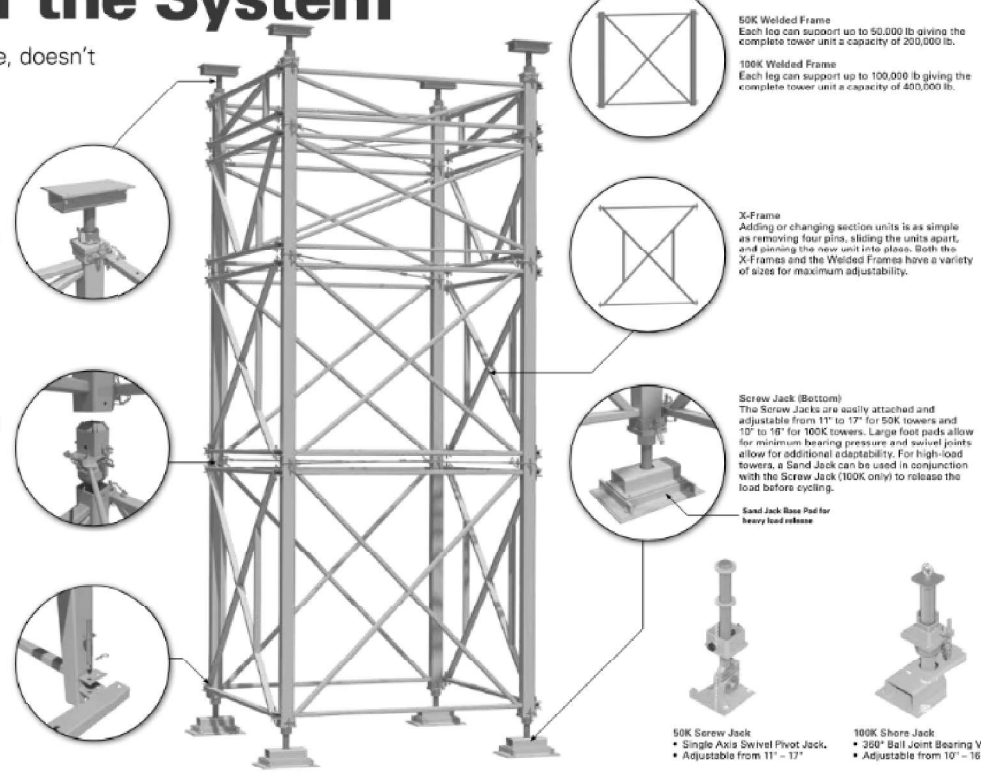

- 50K Screw Jack**
 - Single Axis Swivel Pivot Jack.
 - Adjustable from 11" - 17"
- 100K Shore Jack**
 - 360° Ball Joint Bearing Versatility.
 - Adjustable from 10" - 16"

MAX. LOAD PER LEG
30' = 13 KIPS

Hprop	Bracing frame	
	1,5	2,32
Fully Closed (3.3m)	83kN	83kN
Fully Extended (4.8m)	71kN	73kN

ULMA HEIGHT: from 7.8m to 10.8m (4 Bracing Frames)

TABLE 1: ULMA PROPOSED EFCO 50K/100K SHORING SYSTEM FOR BRACING FRAMES IN HEIGHT

Bracing height to the top of the tower (m)	Bracing height to the top of the tower (ft)	Bracing height to the top of the tower (ft)	Working load	
			50K (kN)	100K (kN)
7.8	25.6	25.6	13.0	26.0
8.3	27.2	27.2	13.0	26.0
8.8	28.9	28.9	13.0	26.0
9.3	30.5	30.5	13.0	26.0
9.8	32.2	32.2	13.0	26.0
10.3	33.8	33.8	13.0	26.0
10.8	35.4	35.4	13.0	26.0

FOR APPROVAL
NOT FOR CONSTRUCTION

GENERAL NOTES:
1. ULMA SHALL BE RESPONSIBLE FOR THE STABILITY AND STRUCTURAL INTEGRITY OF THE EXISTING STRUCTURE BEFORE DURING THE CONSTRUCTION OF THE SHORING SYSTEM. THE CONTRACTOR SHALL BE RESPONSIBLE FOR THE STABILITY OF THE SHORING SYSTEM DURING THE CONSTRUCTION OF THE SHORING SYSTEM.
2. THE CONTRACTOR SHALL BE RESPONSIBLE FOR THE STABILITY OF THE SHORING SYSTEM DURING THE CONSTRUCTION OF THE SHORING SYSTEM.
3. THE CONTRACTOR SHALL BE RESPONSIBLE FOR THE STABILITY OF THE SHORING SYSTEM DURING THE CONSTRUCTION OF THE SHORING SYSTEM.
4. THE CONTRACTOR SHALL BE RESPONSIBLE FOR THE STABILITY OF THE SHORING SYSTEM DURING THE CONSTRUCTION OF THE SHORING SYSTEM.
5. THE CONTRACTOR SHALL BE RESPONSIBLE FOR THE STABILITY OF THE SHORING SYSTEM DURING THE CONSTRUCTION OF THE SHORING SYSTEM.
6. THE CONTRACTOR SHALL BE RESPONSIBLE FOR THE STABILITY OF THE SHORING SYSTEM DURING THE CONSTRUCTION OF THE SHORING SYSTEM.
7. THE CONTRACTOR SHALL BE RESPONSIBLE FOR THE STABILITY OF THE SHORING SYSTEM DURING THE CONSTRUCTION OF THE SHORING SYSTEM.
8. THE CONTRACTOR SHALL BE RESPONSIBLE FOR THE STABILITY OF THE SHORING SYSTEM DURING THE CONSTRUCTION OF THE SHORING SYSTEM.
9. THE CONTRACTOR SHALL BE RESPONSIBLE FOR THE STABILITY OF THE SHORING SYSTEM DURING THE CONSTRUCTION OF THE SHORING SYSTEM.
10. THE CONTRACTOR SHALL BE RESPONSIBLE FOR THE STABILITY OF THE SHORING SYSTEM DURING THE CONSTRUCTION OF THE SHORING SYSTEM.

CUSTOMER: N/A
PROJECT: SALES ENKOFLEX TOWER
ADDRESS: GENERAL VIEW: SHORING OPTICAL VIEW OF
DATE: 7-15-24
SCALE: 1/8" = 1'-0"
SHEET NO.: SH1
CONTRACT NO.: 76K02

50K ERECTION SCHEMATICS

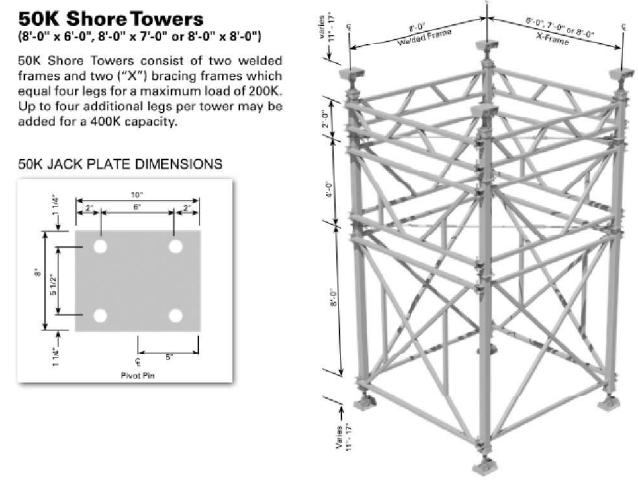

100K ERECTION SCHEMATICS

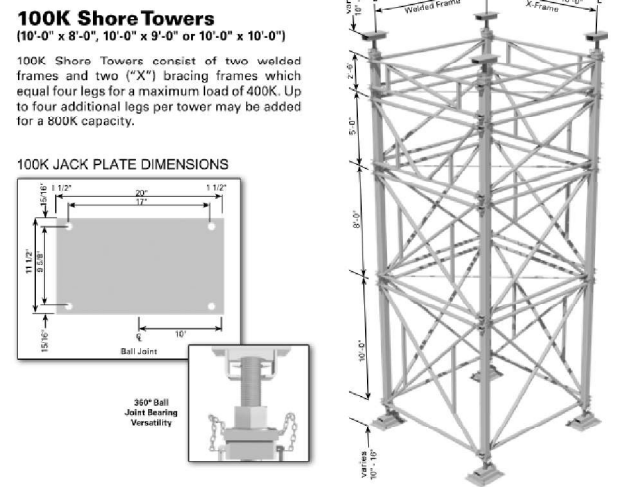

Alternate Tower Configurations (100K examples shown below)

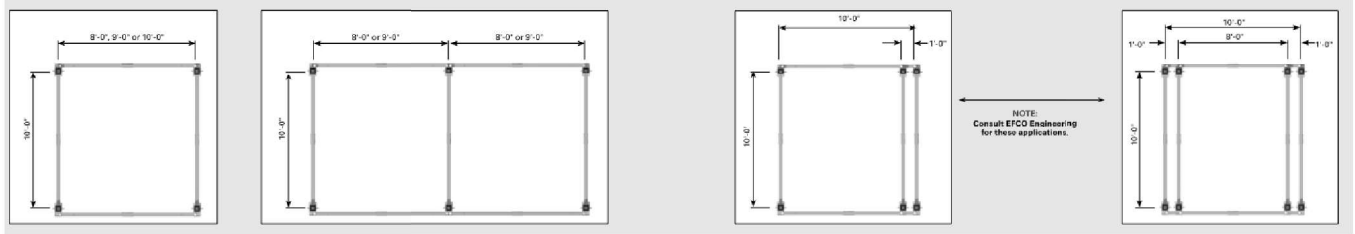

Notes:
1. Excerpts shown are from Manufacturer's available and provided data. Refer to 76K02 - "Excerpts from Manufacturer Reference Data" on the letting site or available upon request.
2. Alternates will be considered, subject to Engineer review and approval. Refer to Special Provisions for Temporary Support System and requirements for "Temporary Support Plan".

MODEL: Default FILE NAME: Z:\15052229 B&O RR Bridge\DN\Bridg\final\Plotsheets\0820017-76K02-092-2-Shoring_Tower_Details_1.dgn

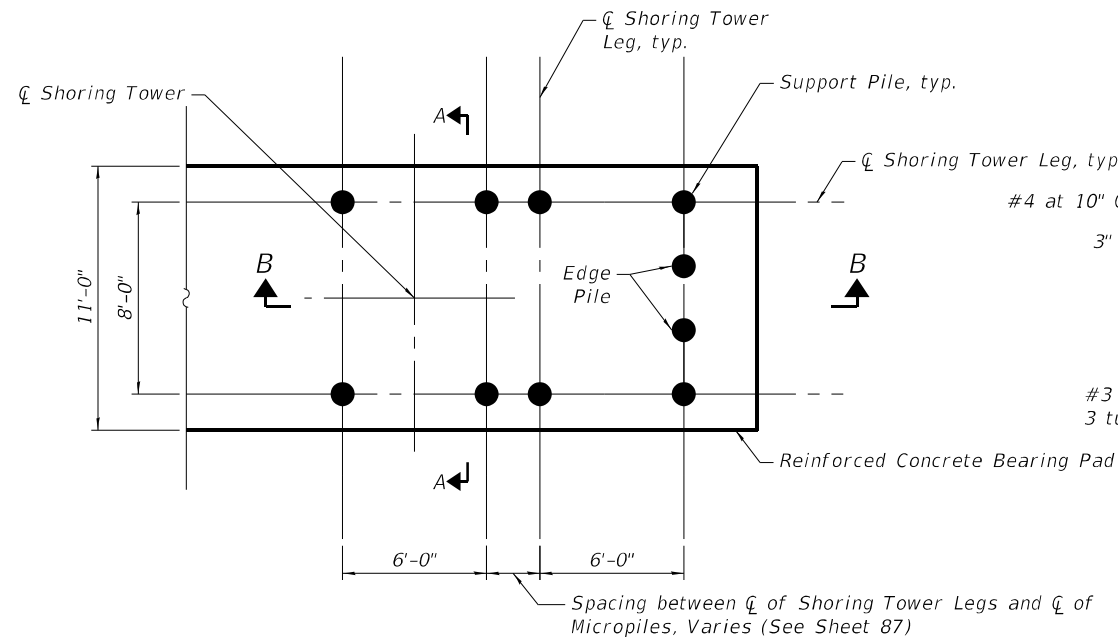

PLAN VIEW - PILE LAYOUT

Note: For Pier 9 WB, see Sheet 86

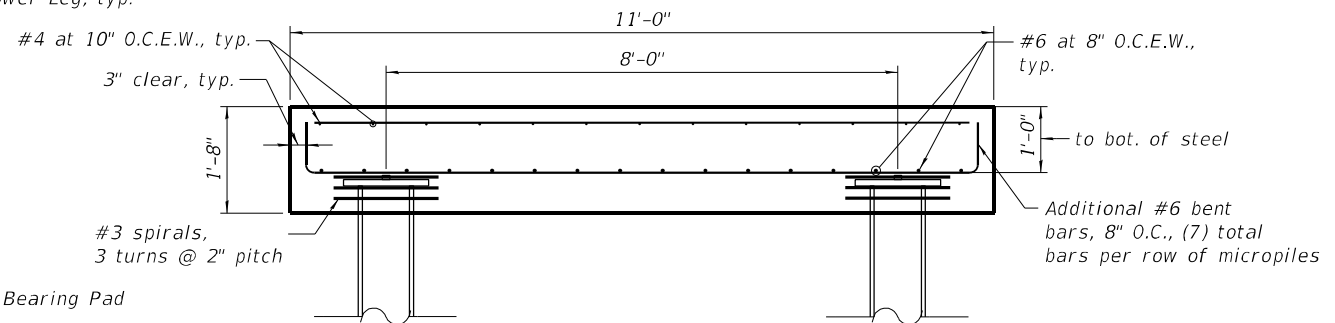

SECTION THRU REINFORCED CONCRETE BEARING PAD AT PILE

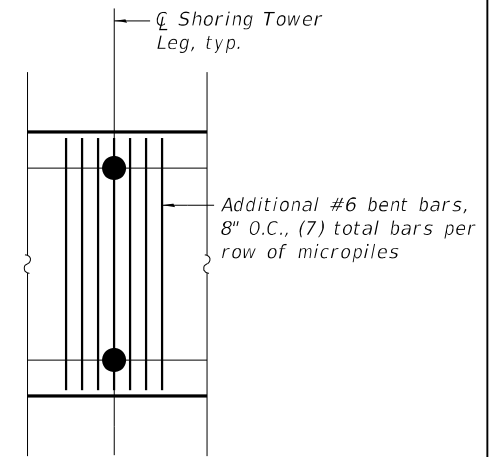

PARTIAL PLAN AT MICROPILE ROW

Note: Primary reinforcement not shown, see Section Thru Concrete Bearing Pad at Pile (this sheet)

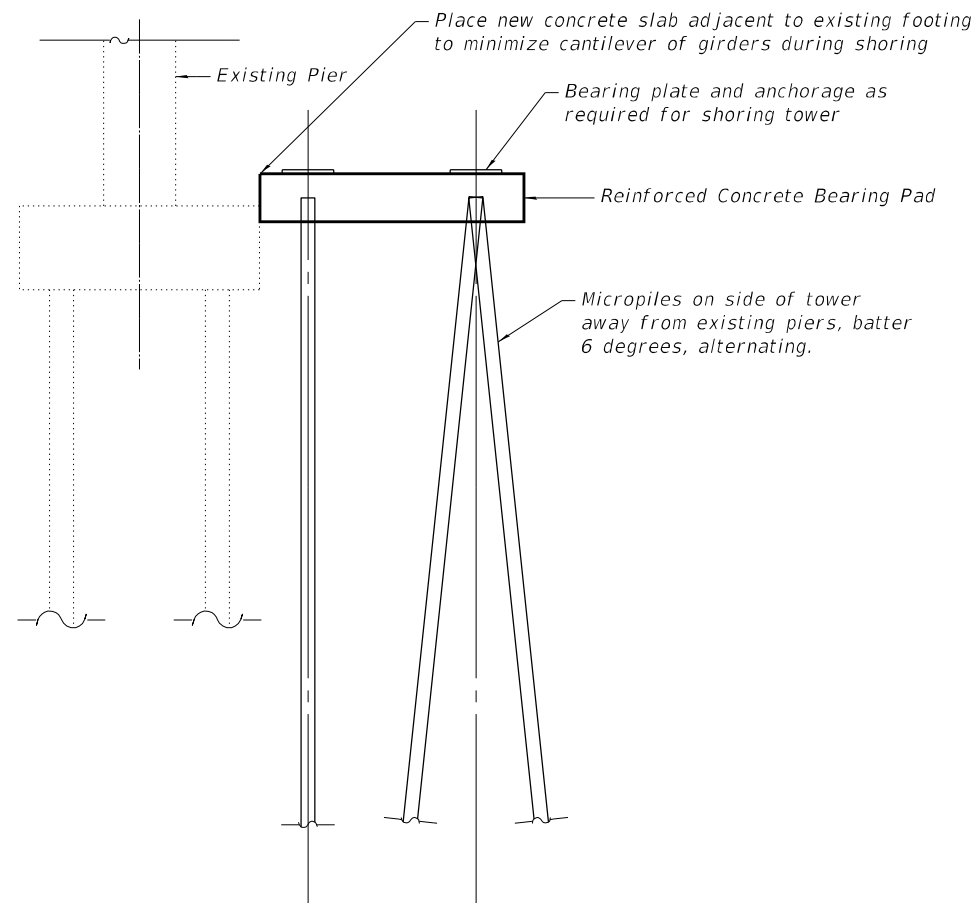

SECTION A-A

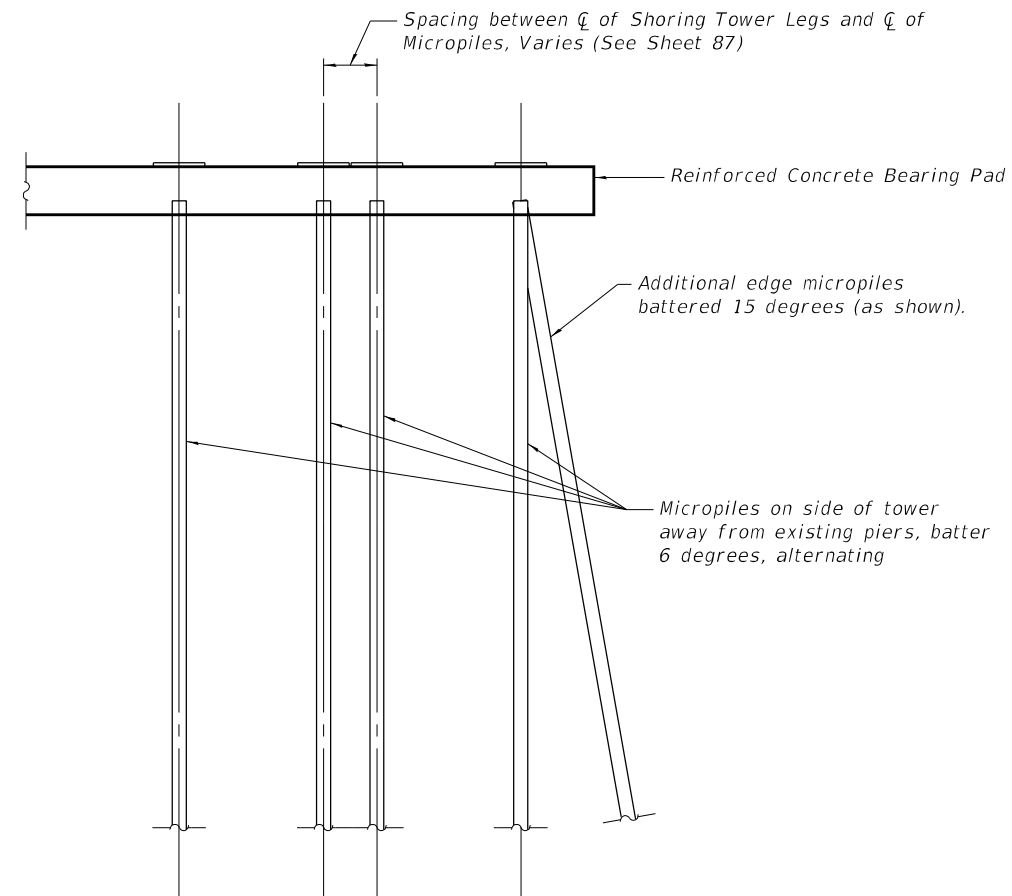

SECTION B-B

MODEL: Default
FILE NAME: Z:\15052.29_B&O_RR_Bridge\DN\Bridg\final\Plotsheets\0820017-76K02-093-Shoring_Tower_Details_2.dgn

WJE ENGINEERS ARCHITECTS MATERIAL SCIENTISTS
Wiss, Janney, Elstner Associates, Inc.
330 Plingsten Road
Northbrook, Illinois 60062
847.272.7400 tel | 847.291.9595 fax
www.wje.com

USER NAME = khill	DESIGNED - SMG/JK	REVISED -
PLOT SCALE = 0.1667"/in.	CHECKED - AW/RAW	REVISED -
PLOT DATE = 8/13/2024	DRAWN - ACB	REVISED -
	CHECKED - SMG/RAW	REVISED -

STATE OF ILLINOIS
DEPARTMENT OF TRANSPORTATION

TYPICAL SHORING TOWER FOUNDATION DETAILS
STRUCTURE NO. 082-0017

SHEET 93 OF 114 SHEETS

F.A.I. RTE.	SECTION	COUNTY	TOTAL SHEETS	SHEET NO.
55/70	82-5VB-R-2	ST. CLAIR	254	231
CONTRACT NO. 76K02				
ILLINOIS FED. AID PROJECT				

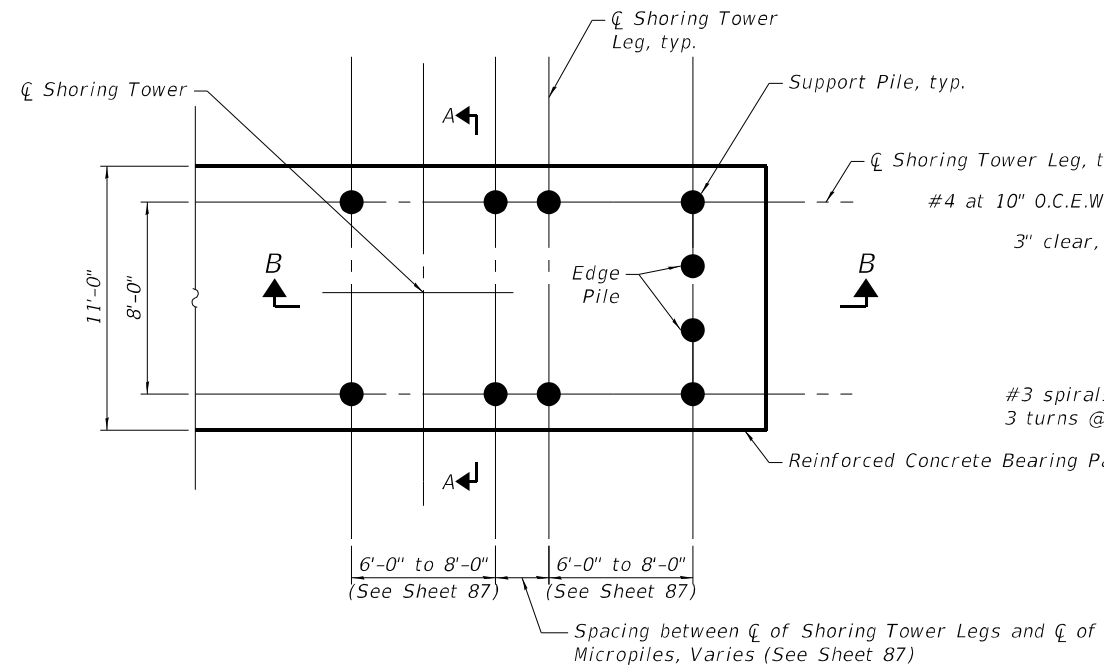

PLAN VIEW - PILE LAYOUT

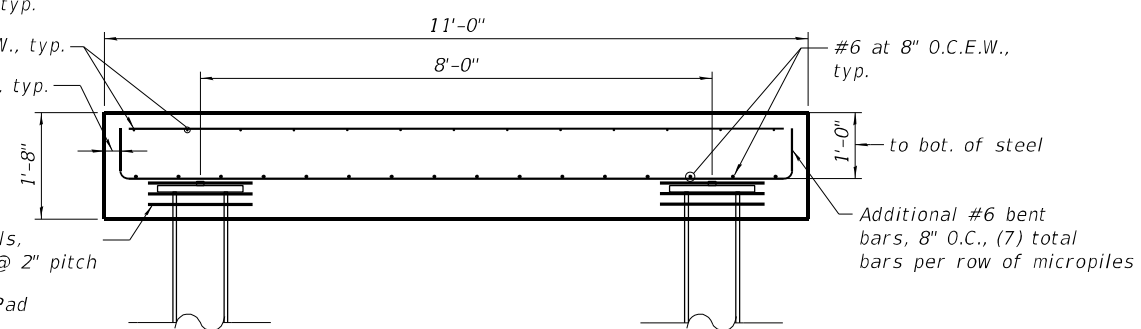

SECTION THRU REINFORCED CONCRETE BEARING PAD AT PILE

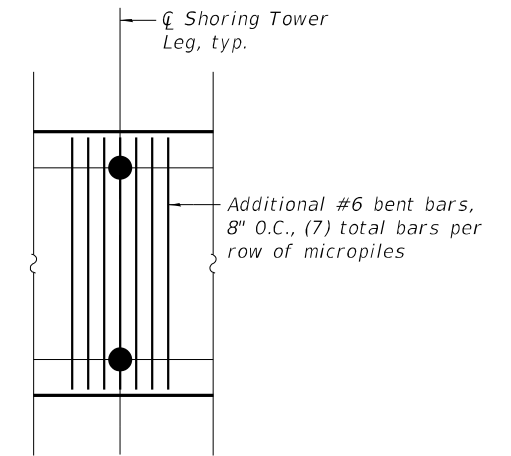

PARTIAL PLAN AT MICROPILE ROW

Note: Primary reinforcement not shown, see Section Thru Concrete Bearing Pad at Pile (this sheet)

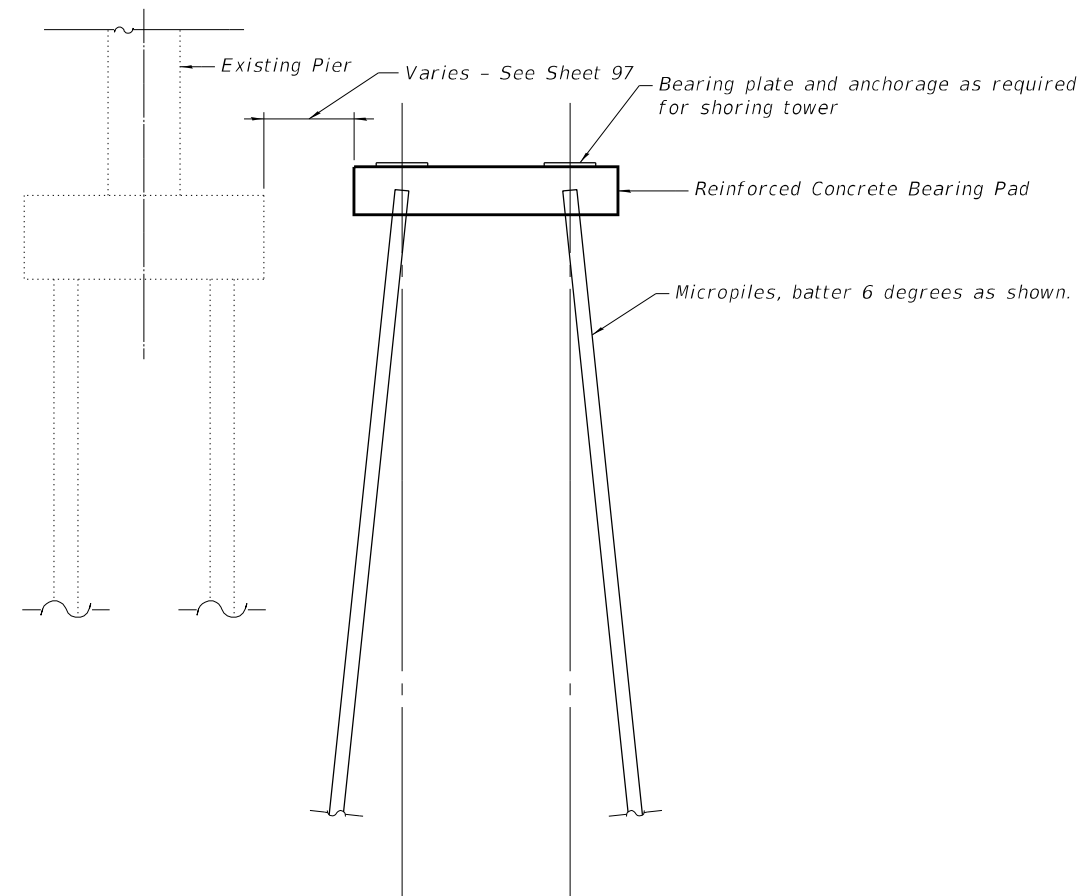

SECTION A-A

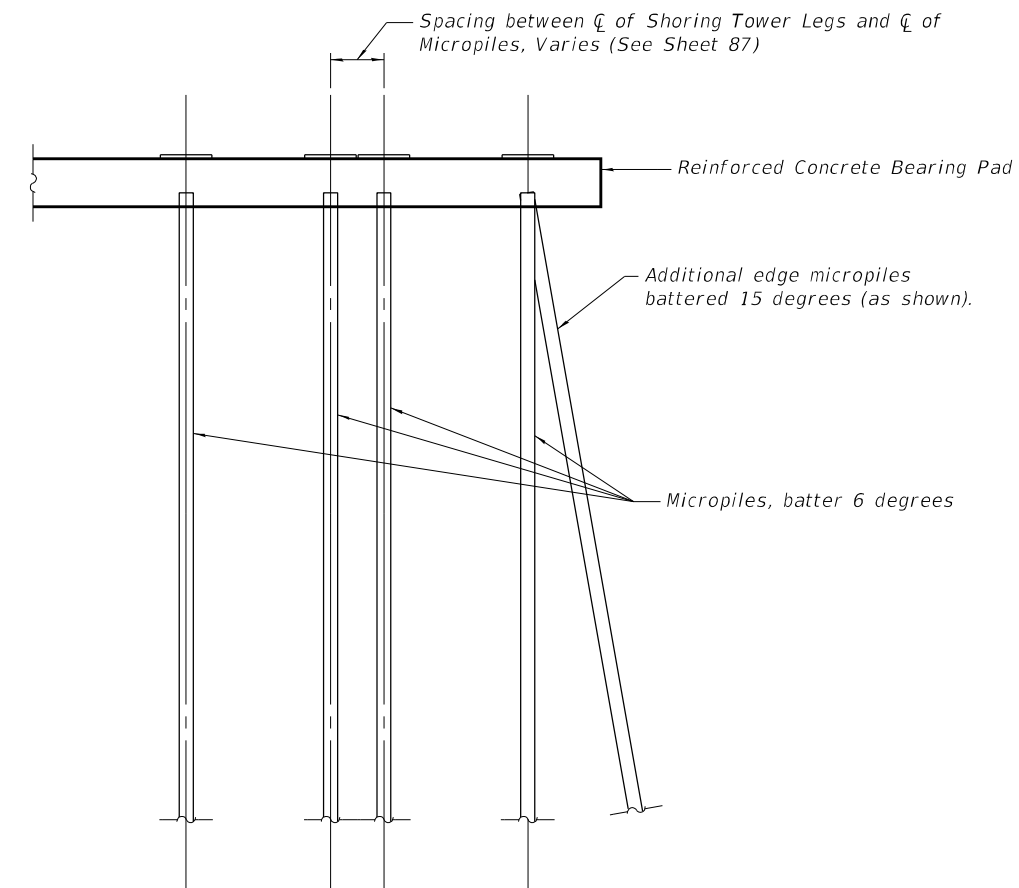

SECTION B-B

MODEL: Default
 FILE NAME: Z:\15052.29 B&O RR Bridge\DCN\Bridg\final\Plotsheets\0820017-76K02-094-Shoring Tower Details 3.dgn

WJE ENGINEERS ARCHITECTS MATERIAL SCIENTISTS
 Wss, Janney, Elstner Associates, Inc.
 330 Pfingsten Road
 Northbrook, Illinois 60062
 847.272.7400 tel | 847.291.9595 fax
 www.wje.com

USER NAME = khill	DESIGNED - SMG/JK	REVISED -
PLOT SCALE = 0.1667"/in.	CHECKED - AW/RAW	REVISED -
PLOT DATE = 8/13/2024	DRAWN - ACB	REVISED -
	CHECKED - SMG/RAW	REVISED -

STATE OF ILLINOIS
 DEPARTMENT OF TRANSPORTATION

PIER 7 STRONGBACK SHORING TOWER FOUNDATION DETAILS
 STRUCTURE NO. 082-0017

SHEET 94 OF 114 SHEETS

F.A.I. RTE.	SECTION	COUNTY	TOTAL SHEETS	SHEET NO.
55/70	82-5VB-R-2	ST. CLAIR	254	232
CONTRACT NO. 76K02				
		ILLINOIS	FED. AID PROJECT	

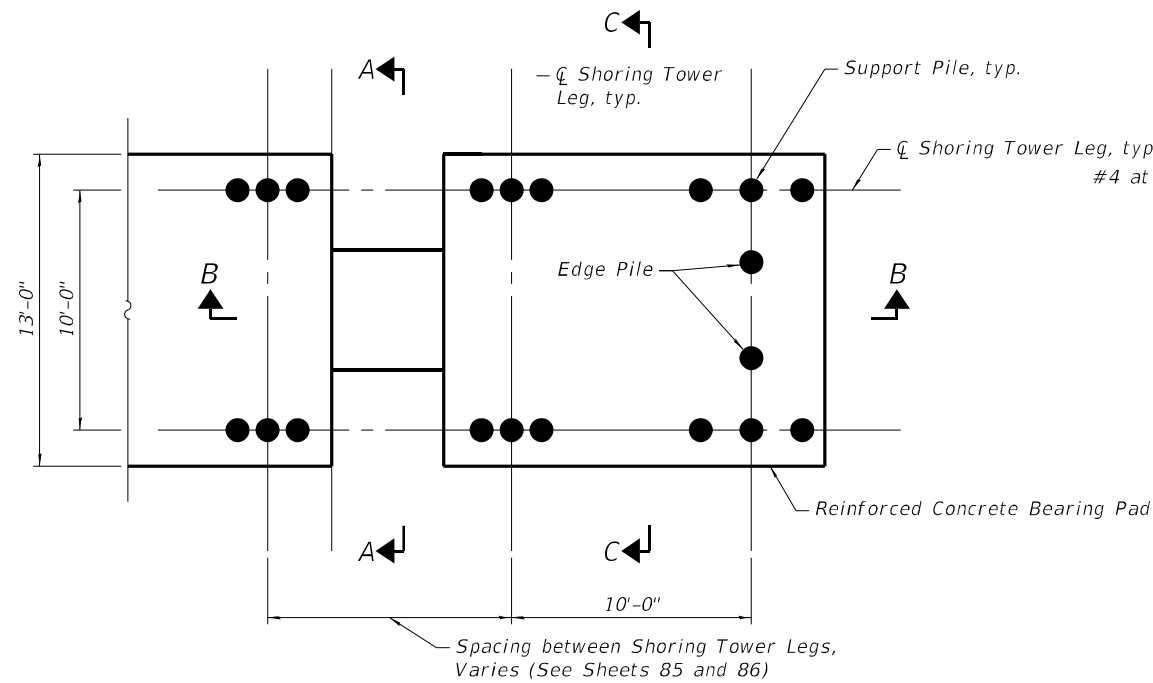

PLAN VIEW - PILE LAYOUT

Note: Maintain 1'-6" edge distance and minimum center to center pile spacing of 12"

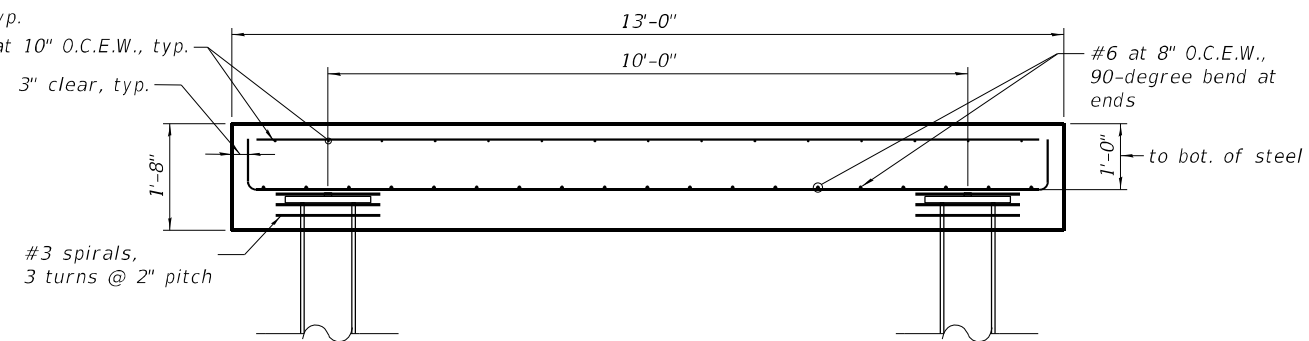

SECTION THRU REINFORCED CONCRETE BEARING PAD AT PILE

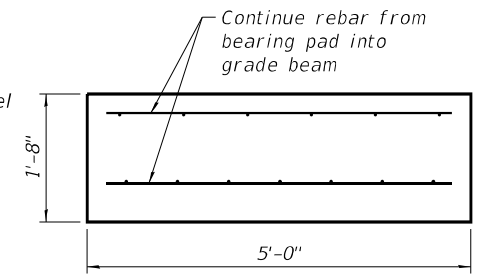

SECTION A-A

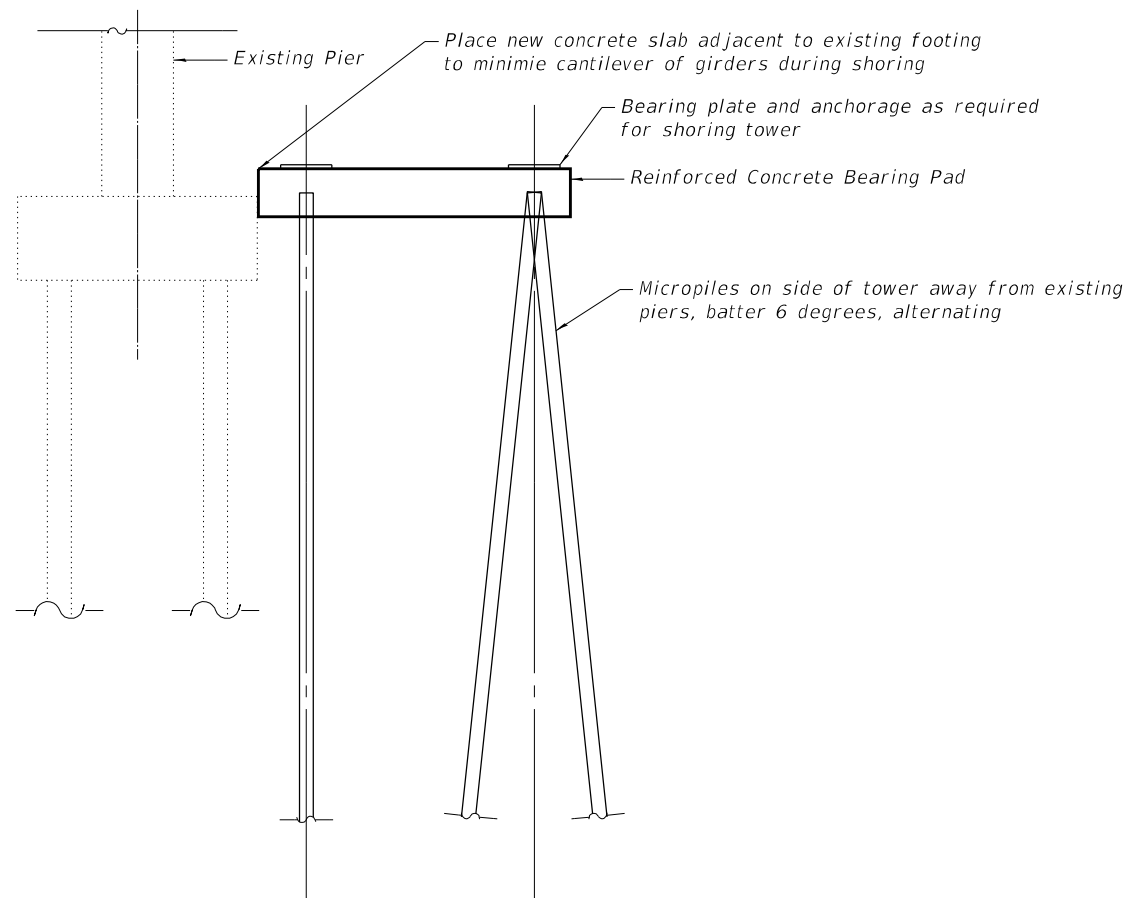

SECTION C-C

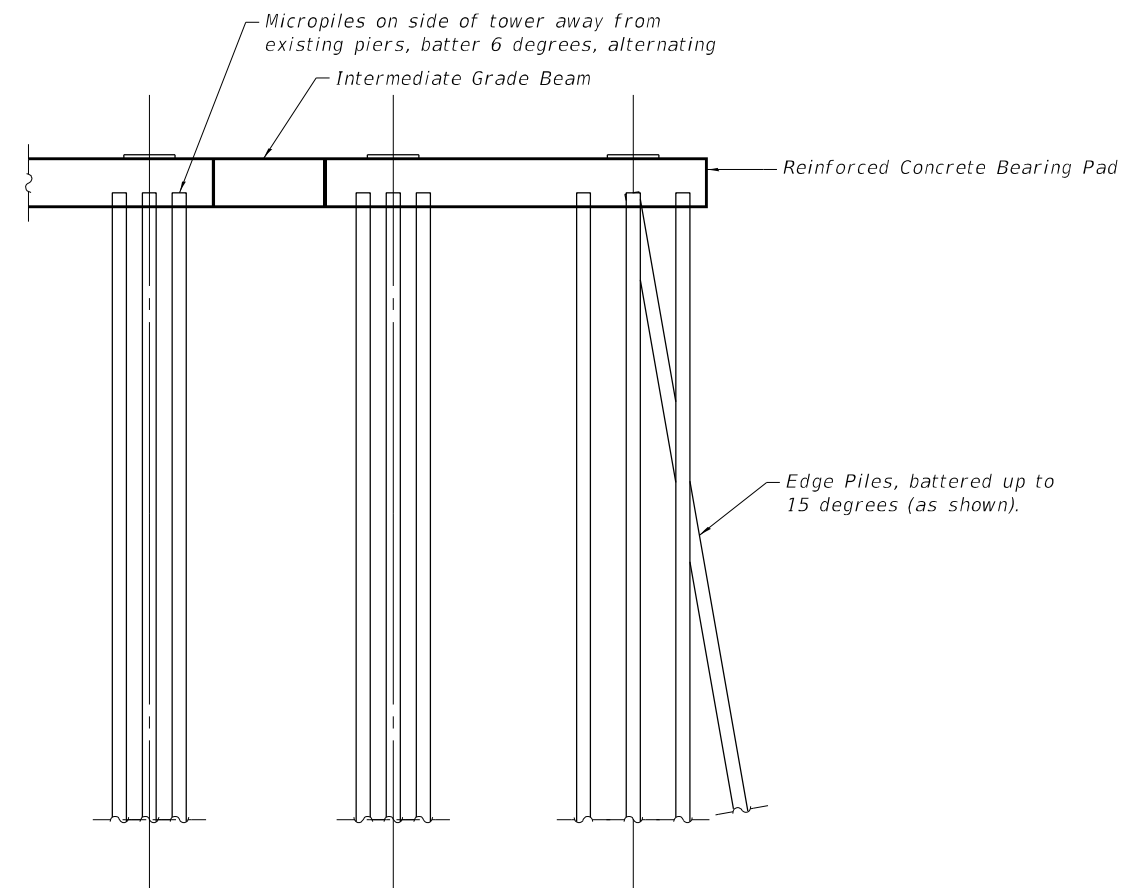

SECTION B-B

MODEL: Default
FILE NAME: Z:\1505229 B&O RR Bridge\DCN\Bridg\final\Plotsheets\0820017-76K02-095-Shoring Tower Details 4.dgn

WJE ENGINEERS ARCHITECTS MATERIAL SCIENTISTS
Wiss, Janney, Elstner Associates, Inc.
330 Pfingsten Road
Northbrook, Illinois 60062
847.272.7400 tel | 847.291.9595 fax

USER NAME = khill	DESIGNED - SMG/JK	REVISED -
PLOT SCALE = 0.1667"/in.	CHECKED - AW/RAW	REVISED -
PLOT DATE = 8/13/2024	DRAWN - ACB	REVISED -
	CHECKED - SMG/RAW	REVISED -

**STATE OF ILLINOIS
DEPARTMENT OF TRANSPORTATION**

**ALTERNATE SHORING TOWER FOUNDATION DETAILS
STRUCTURE NO. 082-0017**

SHEET 95 OF 114 SHEETS

F.A.I. RTE.	SECTION	COUNTY	TOTAL SHEETS	SHEET NO.
55/70	82-5VB-R-2	ST. CLAIR	254	233
CONTRACT NO. 76K02				
ILLINOIS		FED. AID PROJECT		

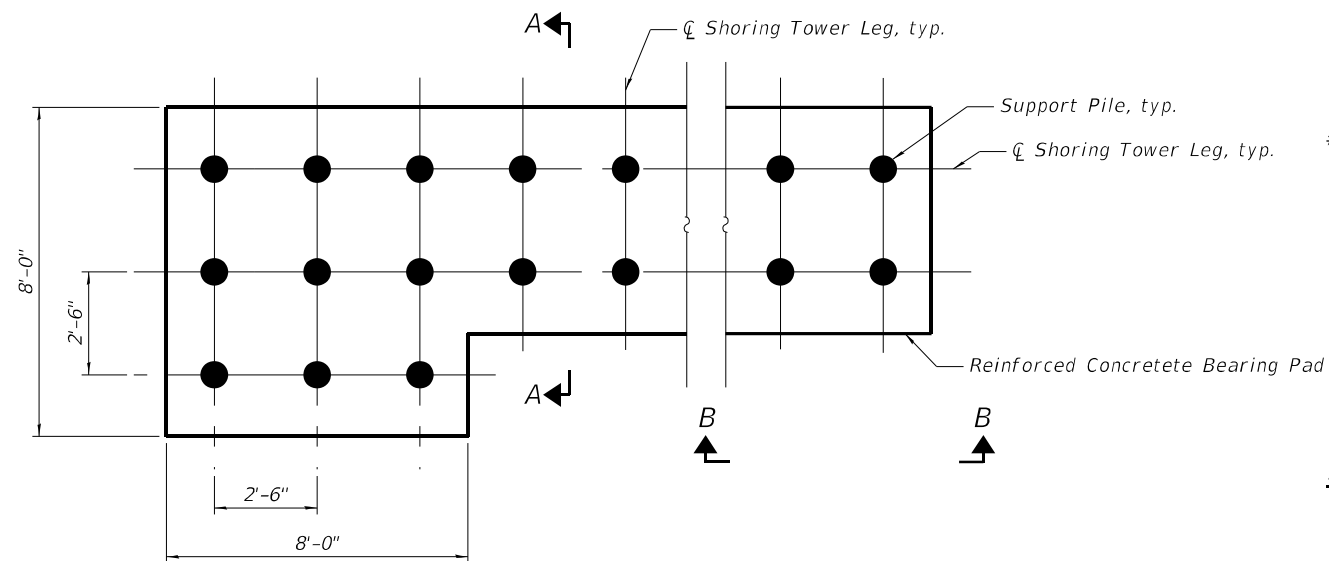

PLAN VIEW - PILE LAYOUT

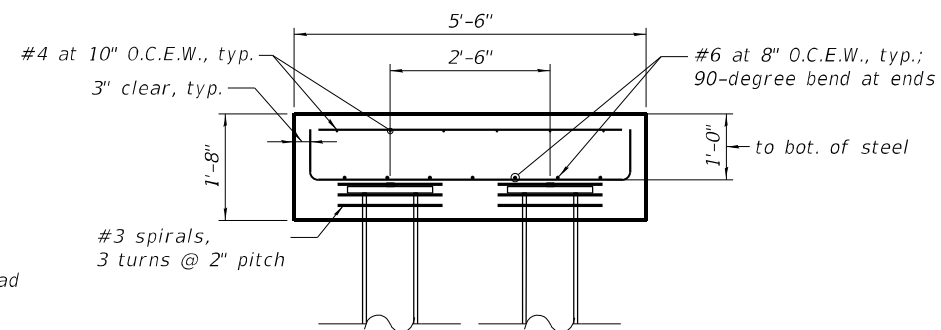

SECTION THRU REINFORCED CONCRETE BEARING PAD AT PILE

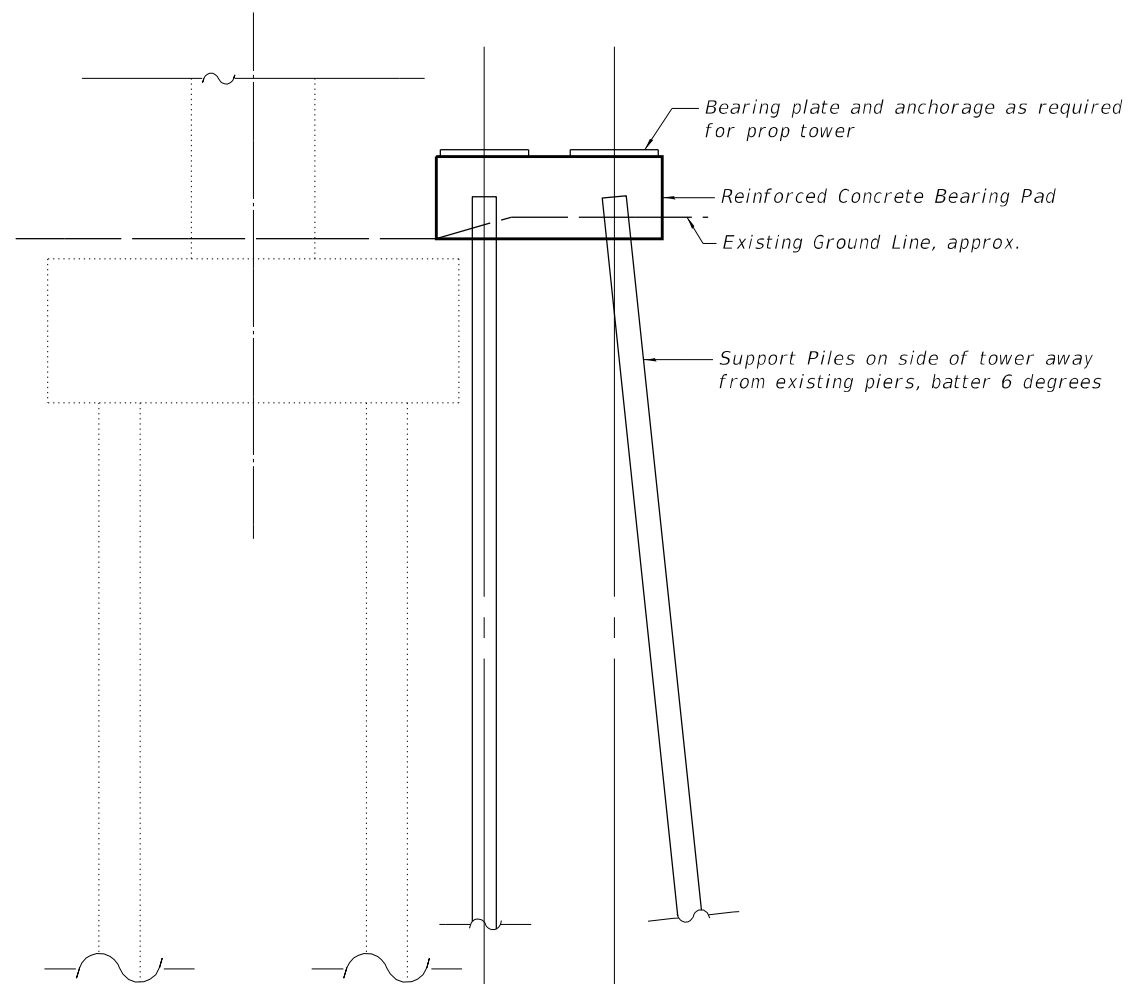

SECTION A-A

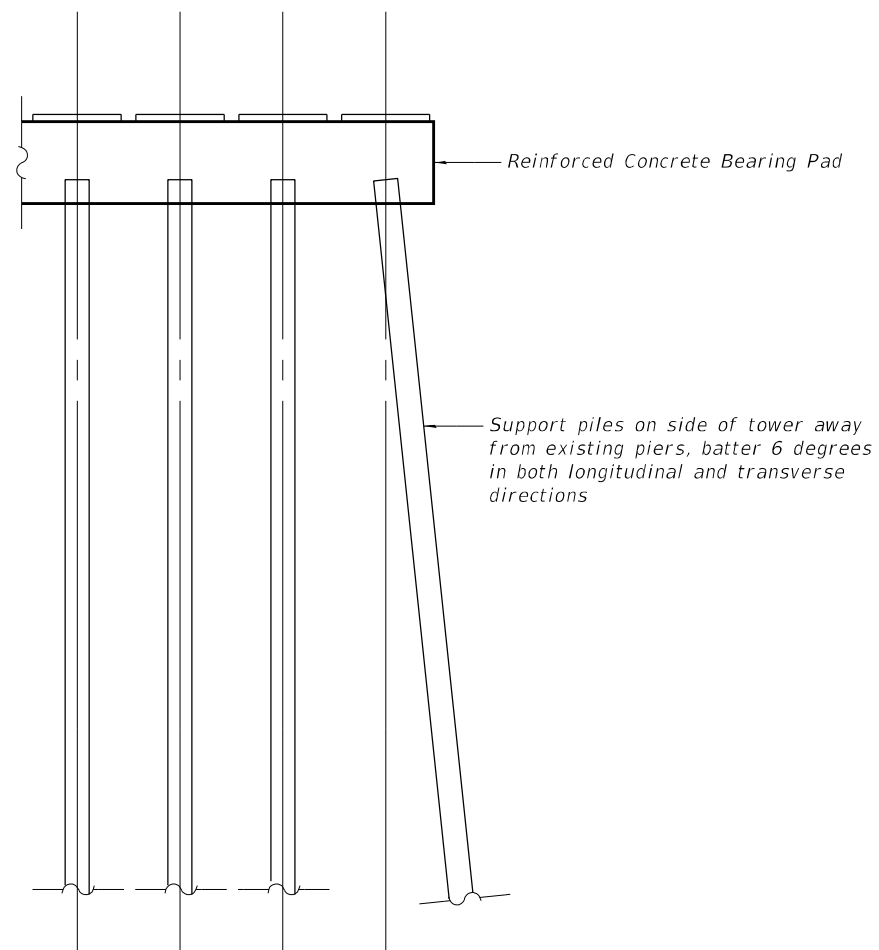

SECTION B-B

MODEL: Default
 FILE NAME: Z:\1505229_B&O_RR_Bridge\DCN\Bridg\final\Plotsheets\0820017-76K02-096-Shoring_Tower_Details_5.dgn

WJE ENGINEERS
 ARCHITECTS
 MATERIAL SCIENTISTS
 Wess, Janney, Elstner Associates, Inc.
 330 Pfingsten Road
 Northbrook, Illinois 60062
 847.272.7400 tel | 847.291.9595 fax
 www.wje.com

USER NAME = khill	DESIGNED - SMG/JK	REVISED -
PLOT SCALE = 0.1667"/in.	CHECKED - AW/RAW	REVISED -
PLOT DATE = 8/13/2024	DRAWN - ACB	REVISED -
	CHECKED - SMG/RAW	REVISED -

STATE OF ILLINOIS
 DEPARTMENT OF TRANSPORTATION

PROP SHORING TOWER FOUNDATION DETAILS
 STRUCTURE NO. 082-0017

SHEET 96 OF 114 SHEETS

F.A.I. RTE.	SECTION	COUNTY	TOTAL SHEETS	SHEET NO.
55/70	82-5VB-R-2	ST. CLAIR	254	234
CONTRACT NO. 76K02				
		ILLINOIS	FED. AID PROJECT	

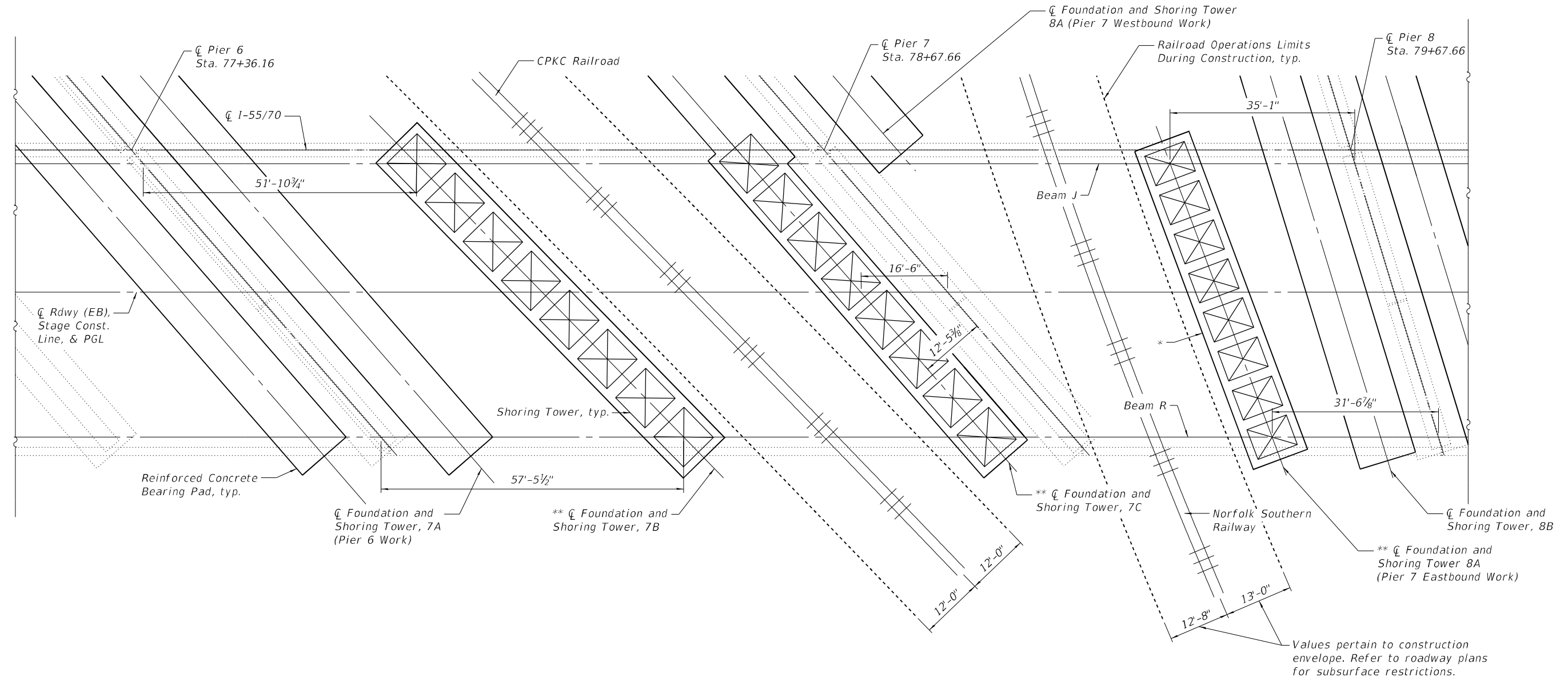
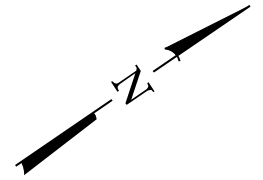

PARTIAL PLAN (SPANS 7 AND 8 - Eastbound)
(Eastbound shoring towers shown)

TEMPORARY SUPPORT SYSTEM REACTION TABLE

Location	Shoring Tower 7B	Shoring Tower 7C	Shoring Tower 8A
Dead Load (k)	145.0	94.9	72.7
Live Load (k)	88.0	90.0	79.3
Impact (k)	29.0	29.8	26.1
Total (k)	262.0	214.7	178.1
Min. Jack Capacity (k)	400	350	300

*New foundation for temporary shoring system. No subsurface work within Norfolk Southern Zones 2 or 3 (See roadway plans). Sheeting may be required for soil stability around new foundations.

**Shoring Towers in Span 7 and Span 8 labeled 7B, 7C, and 8A will be engaged when repairing the concrete substructure supporting the Eastbound lanes at Pier 7. This assumes, due to required traffic control staging, that work at Pier 7 will be completed during a different phase than other piers. Refer to Sheets 98 through 103 for further shoring details at Pier 7.

MODEL: Default
FILE NAME: Z:\1505229_B&O RR Bridge\DN\Bridg\final\Plotsheets\0820017-76K02-097-Partial Plan - Span 7 and 8.dgn

WJE ENGINEERS ARCHITECTS MATERIAL SCIENTISTS
Wiss, Janney, Elstner Associates, Inc.
330 Pfingsten Road
Northbrook, Illinois 60062
847.272.7400 tel | 847.291.9595 fax
www.wje.com

USER NAME = khill	DESIGNED - SMG/JK	REVISED -
PLOT SCALE = 0.1667"/in.	CHECKED - AW/RAW	REVISED -
PLOT DATE = 8/13/2024	DRAWN - ACB	REVISED -
	CHECKED - SMG/RAW	REVISED -

**STATE OF ILLINOIS
DEPARTMENT OF TRANSPORTATION**

**PARTIAL PLAN - SPAN 7 AND 8 (EB)
STRUCTURE NO. 082-0017**

SHEET 97 OF 114 SHEETS

F.A.I. RTE.	SECTION	COUNTY	TOTAL SHEETS	SHEET NO.
55/70	82-5VB-R-2	ST. CLAIR	254	235
CONTRACT NO. 76K02				
		ILLINOIS	FED. AID PROJECT	

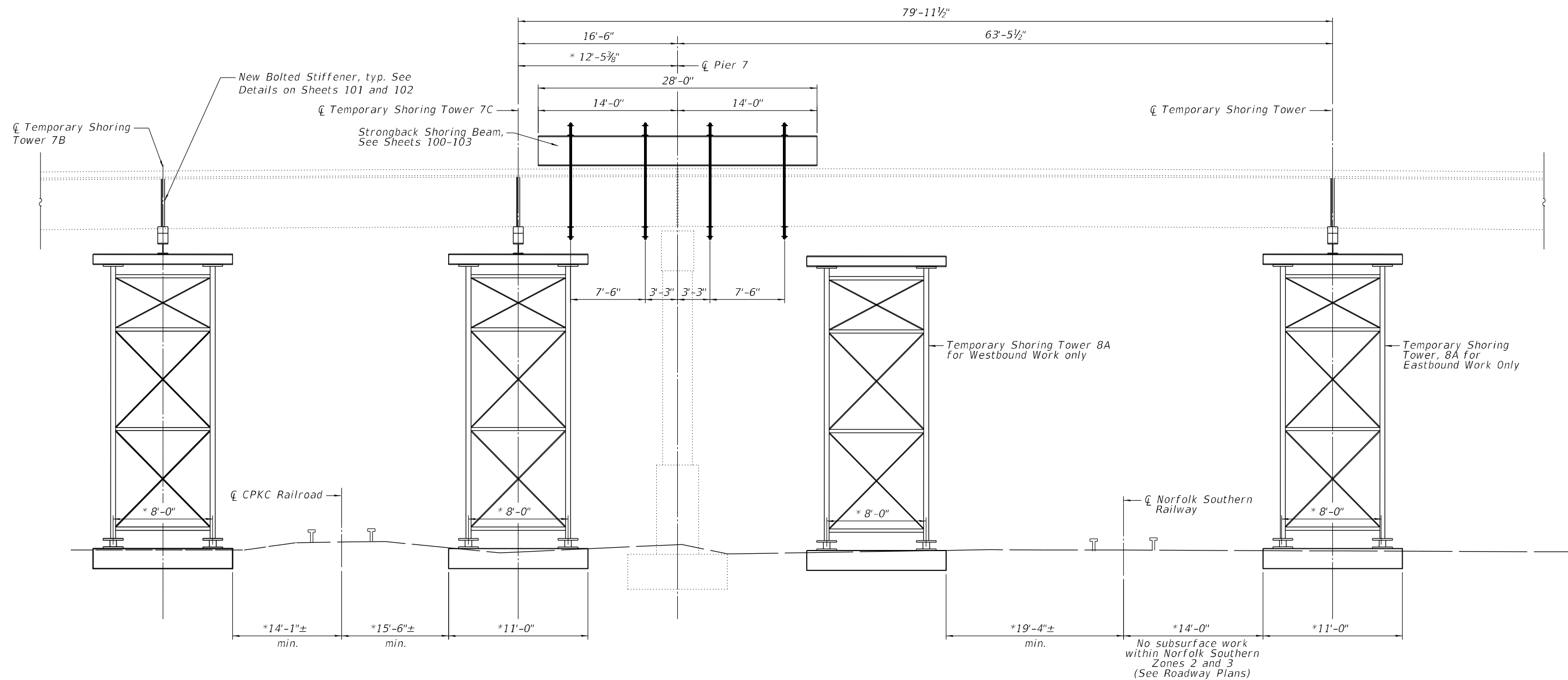

PIER 7 - ELEVATION VIEW (BEAM J)
 *Looking North, Perpendicular to shoring towers

MODEL: Default
 FILE NAME: Z:\1505229_B&O_RR_Bridge\DCIN\Bridg\final\Plotsheets\0820017-76K02-098-Pier 7 - Beam J.dgn

WJE ENGINEERS ARCHITECTS MATERIAL SCIENTISTS
 Wss, Janney, Elstner Associates, Inc.
 330 Pfingsten Road
 Northbrook, Illinois 60062
 847.272.7400 tel | 847.291.9595 fax
 www.wje.com

USER NAME = khill	DESIGNED - SMG/JK	REVISED -
PLOT SCALE = 0.1667"/in.	CHECKED - AW/RAW	REVISED -
PLOT DATE = 8/13/2024	DRAWN - ACB	REVISED -
	CHECKED - SMG/RAW	REVISED -

STATE OF ILLINOIS
 DEPARTMENT OF TRANSPORTATION

PIER 7 - ELEVATION VIEW (BEAM J)
STRUCTURE NO. 082-0017
 SHEET 98 OF 114 SHEETS

F.A.I. RTE. 55/70	SECTION 82-5VB-R-2	COUNTY ST. CLAIR	TOTAL SHEETS 254	SHEET NO. 236
CONTRACT NO. 76K02				
		ILLINOIS	FED. AID PROJECT	

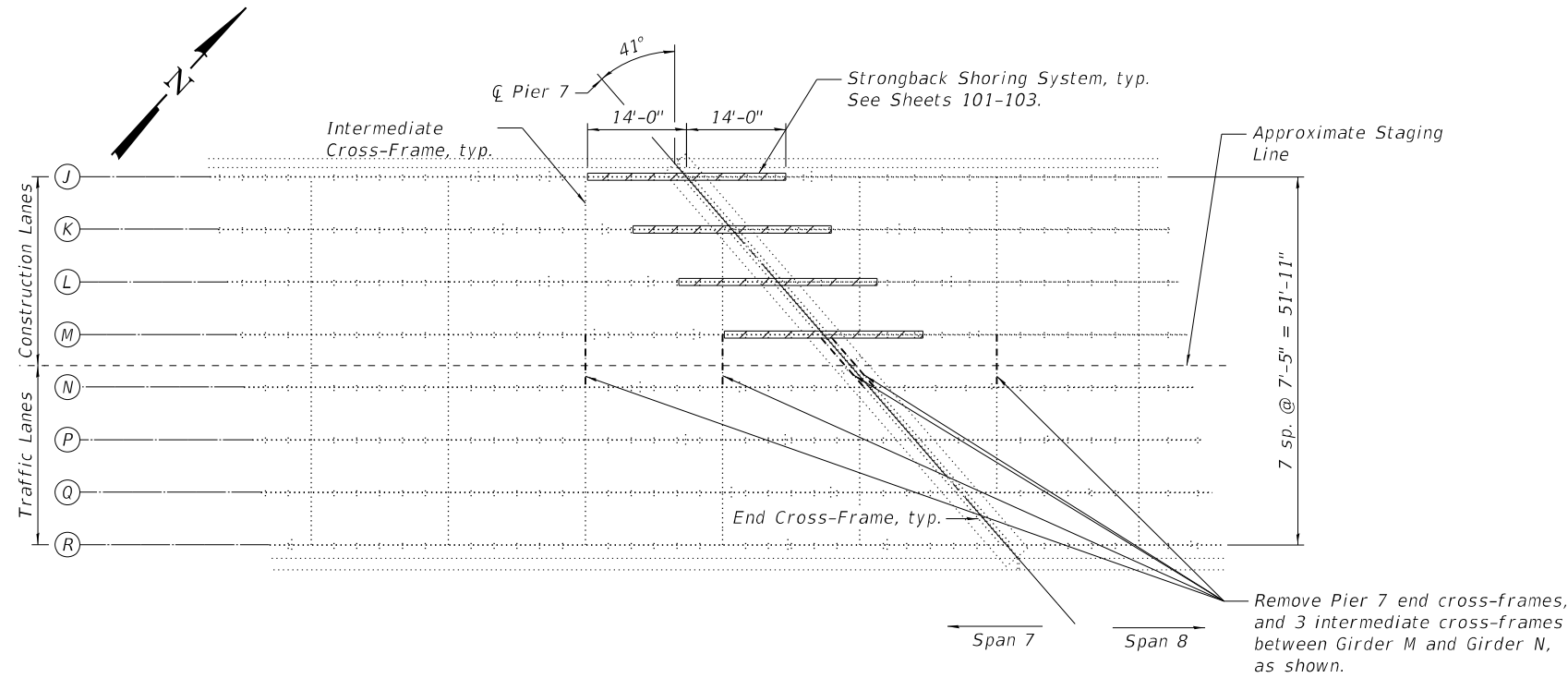

PIER 7 STRONGBACK SHORING - PARTIAL PLAN (STAGE 3)

Shoring towers not shown for clarity. Work this sheet with Sheet 98.

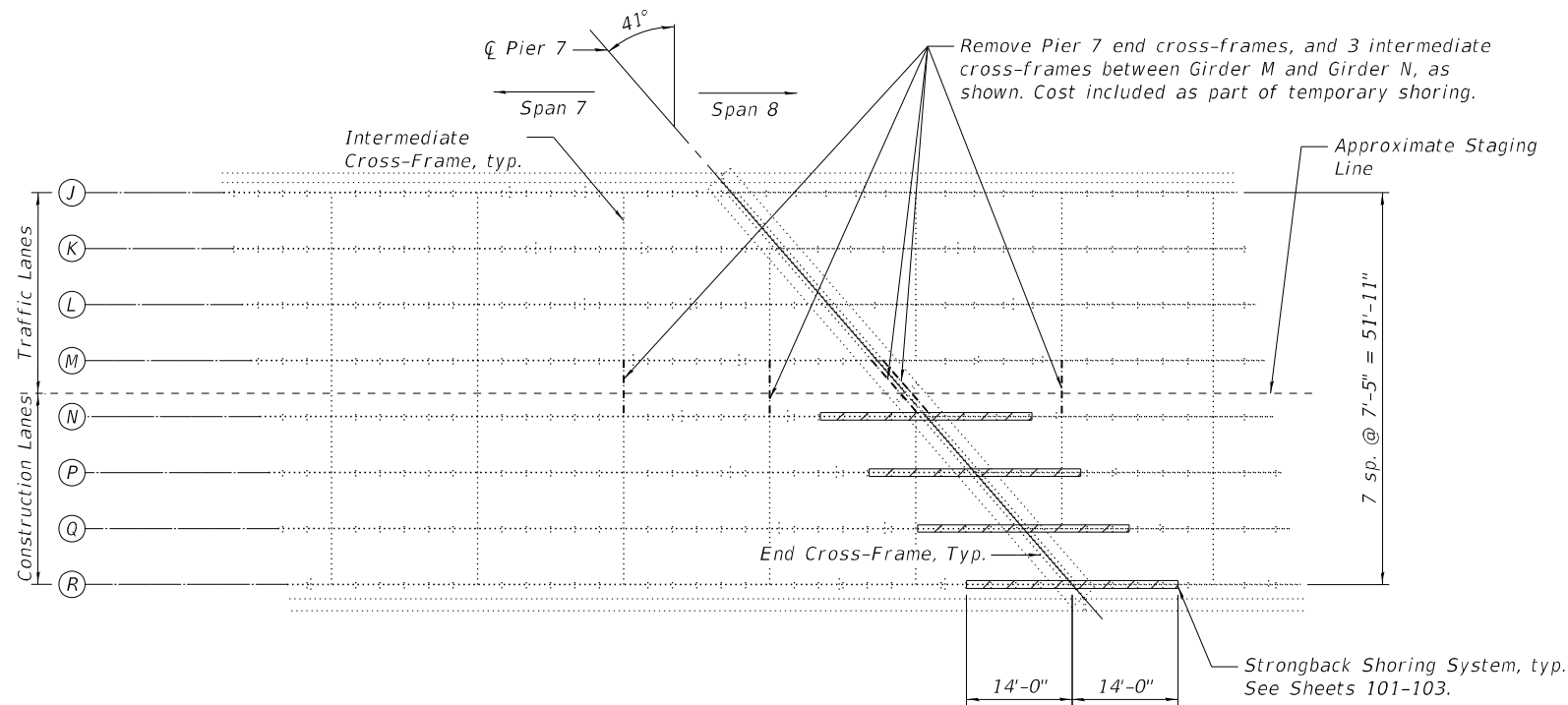

PIER 7 STRONGBACK SHORING - PARTIAL PLAN (STAGE 4)

Shoring towers not shown for clarity. Work this sheet with Sheet 99.

GENERAL NOTES FOR STRONGBACK SHORING SYSTEM:

- Dial gauges shall be used to continuously monitor jack pressures throughout jacking operations. If expected jack pressures are exceeded, work shall immediately stop and shall not be allowed to progress until the jack pressures are brought back to expected values or the observed jack pressures are deemed acceptable by a Structural Engineer licensed in the State of Illinois.
- Vertical movement of the girders shall be continuously monitored throughout jacking operations using benchmarks at the piers, dial gauges, or some other equivalent means.
- Structural steel for the strongback W-beam and channel brackets shall be AASHTO M270, Grade 50. Steel plates for stiffeners, connection plates, bearing plates, shims, and batten plates for the strongback system shall be ASTM A572, Grade 50 or equivalent. Bolts shall be ASTM F3125 Gr A325 unless noted otherwise.
- Threaded rods shall be Grade 150 steel.
- All welding shall be performed using E70XX electrodes and shall conform to AASHTO/AWS D1.5 - Bridge Welding Code.
- Prior to installing the strongback beams, all heavy or loose rust, loose mill scale, and other loose detrimental foreign material shall be removed for the girder bottom flanges in accordance with SSPC-SP3 - Power Tool Cleaning.
- Dimensions shown are based on the original construction drawings and rehabilitation drawings. The Contractor shall field-verify all dimensions shown prior to installing any temporary shoring.
- Ground-penetrating radar (GPR) or equivalent non-destructive method(s) shall be used to locate the deck reinforcement prior to installing the strongback system. Cutting or burning the existing deck reinforcement shall be minimized. Once jacking operations have been completed and the strongback system demobilized, the holes in the concrete deck shall be filled with an approved grout or full-depth concrete repairs shall be performed.
- Bolts, chords, and diagonals of the cross-frames in Span 7 & 8 shall be repaired or replaced in accordance with Sheets 30 to 36 prior to temporary shoring in Span 7 or 8.
- Framing, details, and notes on Sheets 100 through 103 are considered included in the cost for temporary shoring, Location 3.

CONCEPTUAL JACKING SEQUENCE FOR SPAN 7 & SPAN 8:

- Stage the traffic control, temporary barriers, and shoring towers at Tower Lines 7B, 7C, and 8A in accordance with these Contract Documents. Refer to Sheet 97-99 for locations and reactions for Temporary Shoring Tower Lines 7B, 7C, and 8A.
- Locate and mark the limits of the strongback system on the concrete deck and girders.
- Install the strongback beams with channel brackets and threaded rods at Girder J through Girder M (Stage 3) or Girder N through Girder R (Stage 4). Tighten the threaded rods until the channel brackets are tight to the built-up girders.
- Prior to jacking the girders at the shoring towers, detach the cross-frames between Girder M and Girder N as shown in the partial plans on this sheet (five cross-frames total).
- Girders J through R shall be closed to traffic during lifting operations. Refer to roadway plans for closure intervals and additional traffic control requirements. Heavy equipment and materials shall not be stored on Span 7 or Span 8 during lifting operations or while bearings are being removed or replaced.
- Jack Girders J through R at Tower Lines 7C and 8A until girder liftoff is achieved for Girder J through M at Pier 7. The two tower lines shall be engaged to the girders simultaneously. Once girder liftoff is achieved, the Span 7 and Span 8 bearings at Pier 7 shall be removed under Girders J through M.
- After bearings are removed, engage Tower Line 7B. Adjust the jacking pressures at Tower lines 7B, 7C, and 8A until the expected dead load reactions have been achieved at each shoring tower line. Refer to Sheet 97 for expected shoring tower reactions.
- Once the expected shoring tower reactions are achieved, the jacks shall be locked off or temporary bearings shall be installed at all temporary shoring tower locations to disengage hydraulics. Install steel shim plates at the Pier 7 bearings supporting Girders N through R as required to re-establish bearing prior to re-opening traffic.
- Perform concrete repairs on the concrete pier cap and columns supporting Girders J through M.
- Once the repaired concrete has reached its design compressive strength, the replacement bearings may be installed under Girders J through M.
- Close traffic over Girders N through R.
- Reinstall the jacks at the shoring towers and slowly increase the jack pressure to disengage the shim plates installed in Step 5 and to disengage any temporary bearings at the shoring towers.
- Lower the jack pressure at the shoring towers and transfer the load to the bearings at Pier 6, Pier 7, and Pier 8.
- Remove the jacks, shoring towers, and strongback system.
- Repeat Steps 1 through 14 for Stage 4 construction.

DESIGN LOADING (PIER 7 EB REPLACEMENT)

- Lateral Load: AASHTO LRFD Braking and Wind Loading
- Vertical Load (Construction Lanes) - Construction Live Loading of 75 PSF with Single HS-20
- Vertical Load (Traffic Lanes) - AASHTO LRFD Design Live Loading (HL-93)

Note: Refer to Sheet 97 for Shoring Tower Reactions during Pier 7 EB replacement.

MODEL: Default
FILE NAME: Z:\1505229_B&O_RR_Bridge\DCN\Bridg\final\Plotsheets\0820017-76K02-100-Pier 7 - Partial Framing.dgn
8/13/2024 9:42:29 AM

WJE ENGINEERS ARCHITECTS MATERIAL SCIENTISTS
Wiss, Janney, Elstner Associates, Inc.
330 Pfingsten Road
Northbrook, Illinois 60062
847.272.7400 tel | 847.291.9595 fax

USER NAME = khill	DESIGNED - SMG/JK	REVISED -
PLOT SCALE = 0.1667"/in.	CHECKED - AW/RAW	REVISED -
PLOT DATE = 8/13/2024	DRAWN - ACG	REVISED -
	CHECKED - SMG/RAW	REVISED -

**STATE OF ILLINOIS
DEPARTMENT OF TRANSPORTATION**

**PIER 7 EB - PARTIAL FRAMING PLAN (GIRDERS J-R)
STRUCTURE NO. 082-0017**

SHEET 100 OF 114 SHEETS

F.A.I. RTE.	SECTION	COUNTY	TOTAL SHEETS	SHEET NO.
55/70	82-5VB-R-2	ST. CLAIR	254	238
CONTRACT NO. 76K02				
ILLINOIS		FED. AID PROJECT		

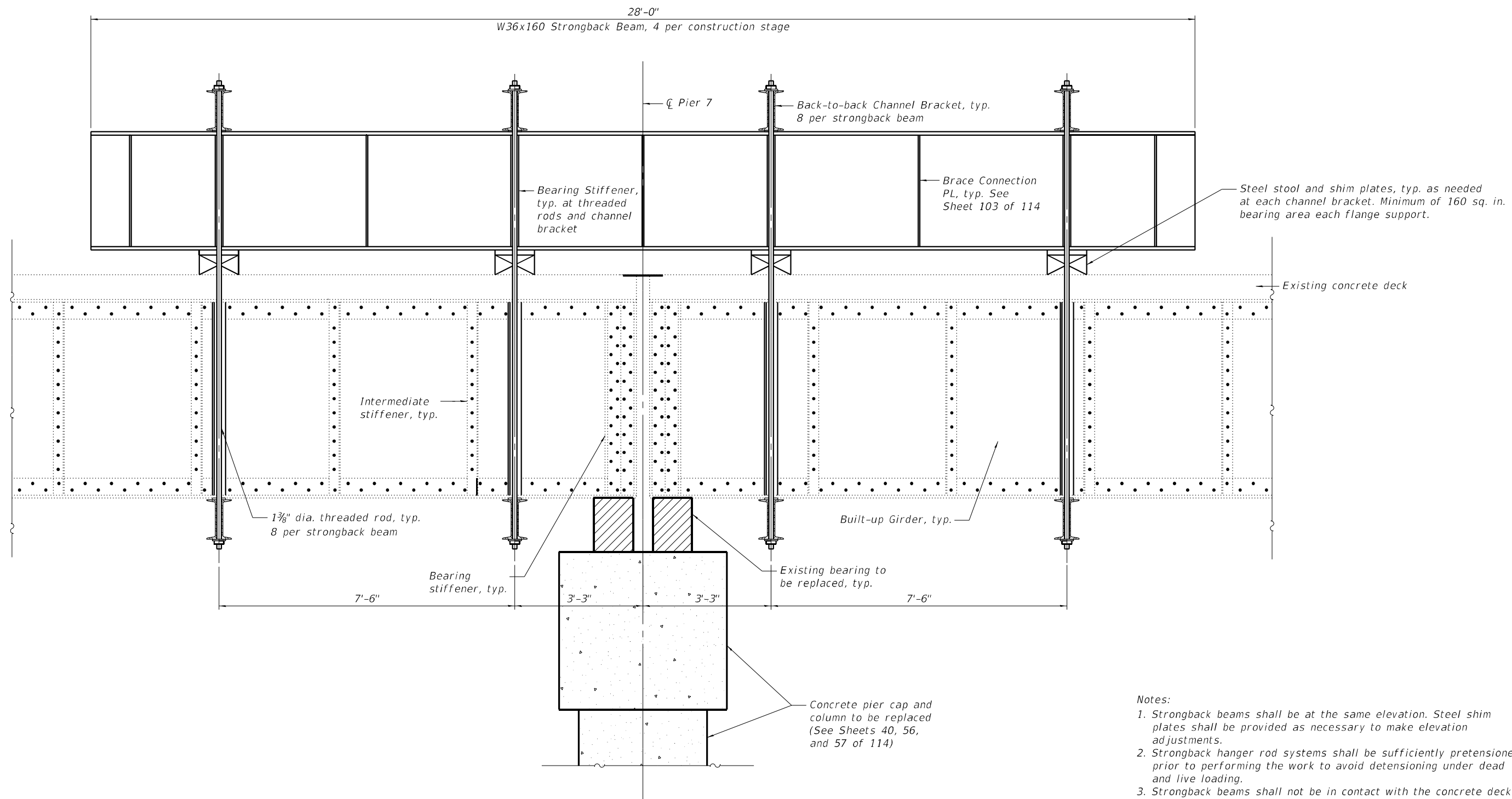

- Notes:
1. Strongback beams shall be at the same elevation. Steel shim plates shall be provided as necessary to make elevation adjustments.
 2. Strongback hanger rod systems shall be sufficiently pretensioned prior to performing the work to avoid detensioning under dead and live loading.
 3. Strongback beams shall not be in contact with the concrete deck.

GIRDER ELEVATION

Girder cross-frames, deck haunch at Pier 7, and strongback bracing not shown for clarity.

MODEL: Default
FILE NAME: Z:\1505229_B&O_RR_Bridge\DCN\Bridges\0820017-76K02-101-Pier 7 - Strongback Beam Details 1.dgn

WJE ENGINEERS ARCHITECTS MATERIAL SCIENTISTS
 Wss, Janney, Elstner Associates, Inc.
 330 Pfingsten Road
 Northbrook, Illinois 60062
 847.272.7400 tel | 847.291.9595 fax
 www.wje.com

USER NAME = khill	DESIGNED - SMG/JK	REVISED -
	CHECKED - AW/RAW	REVISED -
PLOT SCALE = 0.1667"/in.	DRAWN - ACB	REVISED -
PLOT DATE = 8/13/2024	CHECKED - SMG/RAW	REVISED -

**STATE OF ILLINOIS
DEPARTMENT OF TRANSPORTATION**

**PIER 7 EB - STRONGBACK BEAM DETAILS 1
STRUCTURE NO. 082-0017**

SHEET 101 OF 114 SHEETS

F.A.I. RTE.	SECTION	COUNTY	TOTAL SHEETS	SHEET NO.
55/70	82-5VB-R-2	ST. CLAIR	254	239
CONTRACT NO. 76K02				
ILLINOIS		FED. AID PROJECT		

Stage 1 Construction
(Stage 2 Construction Similar)

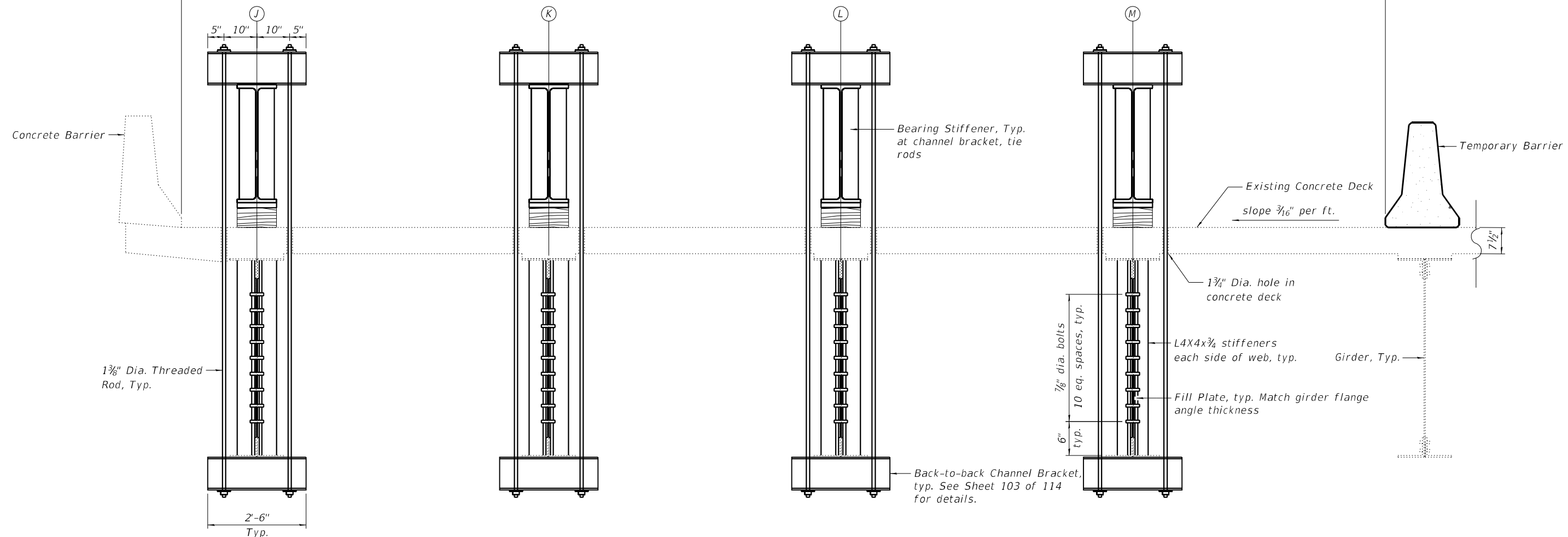

STRONGBACK SECTION VIEW (LOOKING EAST)

Cross-frames, girder stiffeners, and bracing for strongback not shown for clarity

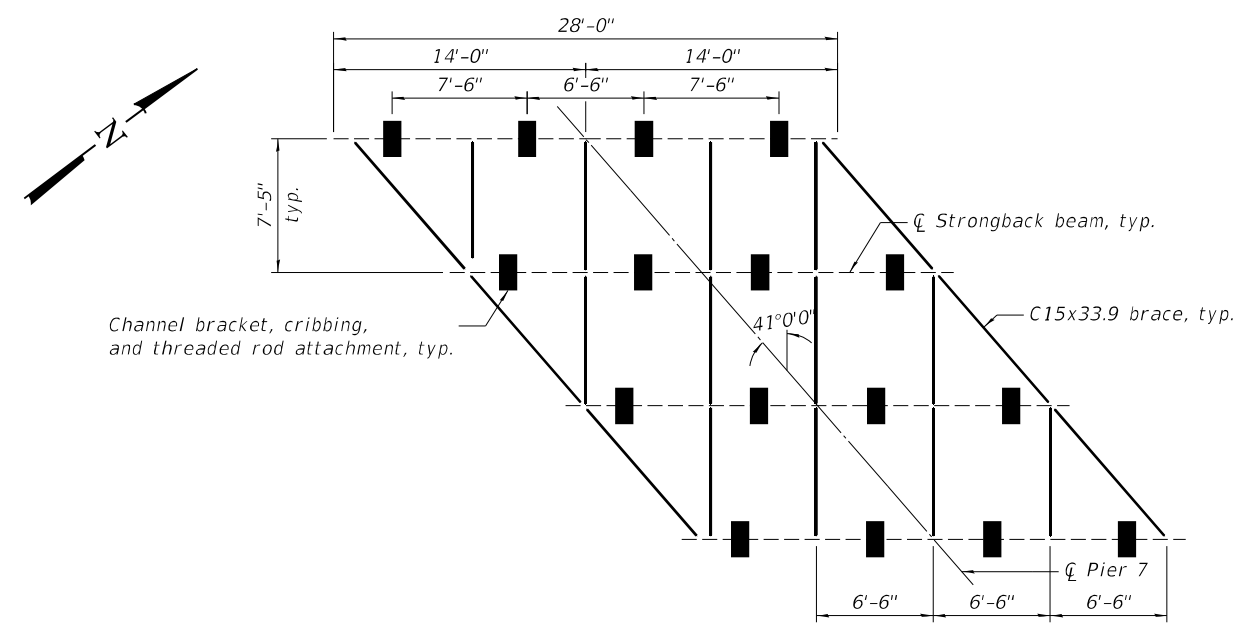

STRONGBACK FRAMING PLAN

NOTES:

1. Locate threaded rod and channel bracket attachments such that drilling through the deck will not interfere with the existing steel reinforcement.
2. Bearing stiffeners and connection plates for channel bracing shall be perpendicular to the girder web.
3. See Sheet 103 of 114 for strongback bracing details.
4. See Roadway Plans for Stage Construction Details.

MODEL: Default
FILE NAME: Z:\1505229_B&O_RR_Bridge\DCN\Bridges\final\Plotsheets\0820017-76K02-102-Pier 7 - Strongback Beam Details 2.dgn

WJE ENGINEERS ARCHITECTS MATERIAL SCIENTISTS
Wiss, Janney, Elstner Associates, Inc.
330 Pfingsten Road
Northbrook, Illinois 60062
847.272.7400 tel | 847.291.9595 fax
www.wje.com

USER NAME = khill	DESIGNED - SMG/JK	REVISED -
PLOT SCALE = 0.1667"/in.	CHECKED - AW/RAW	REVISED -
PLOT DATE = 8/13/2024	DRAWN - ACB	REVISED -
	CHECKED - SMG/RAW	REVISED -

STATE OF ILLINOIS
DEPARTMENT OF TRANSPORTATION

PIER 7 EB - STRONG BACK BEAM DETAILS 2
STRUCTURE NO. 082-0017

SHEET 102 OF 114 SHEETS

F.A.I. RTE.	SECTION	COUNTY	TOTAL SHEETS	SHEET NO.
55/70	82-5VB-R-2	ST. CLAIR	254	240
CONTRACT NO. 76K02				
		ILLINOIS	FED. AID PROJECT	

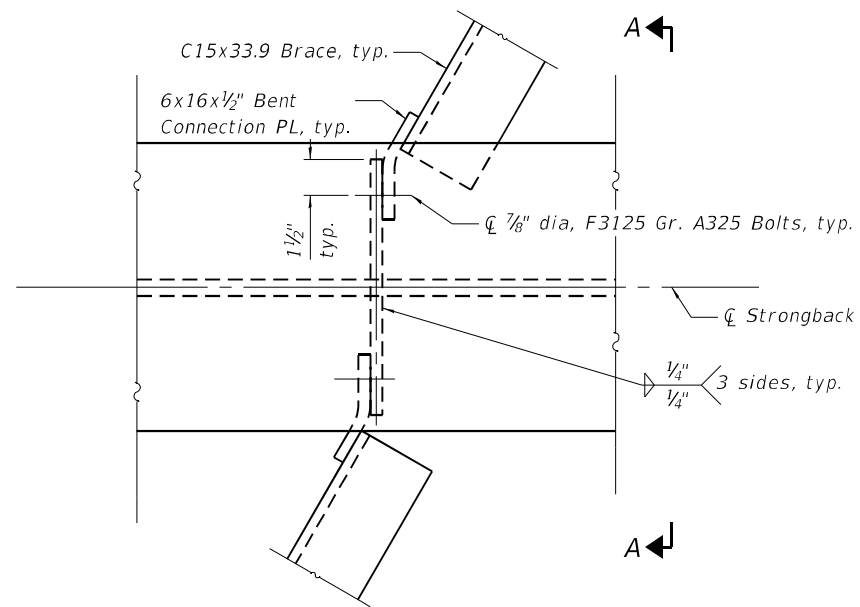

BEARING STIFFENER DETAILS

Showing strongback bracing connections at skewed end braces.
Bent connection plates not required at intermediate brace connections.

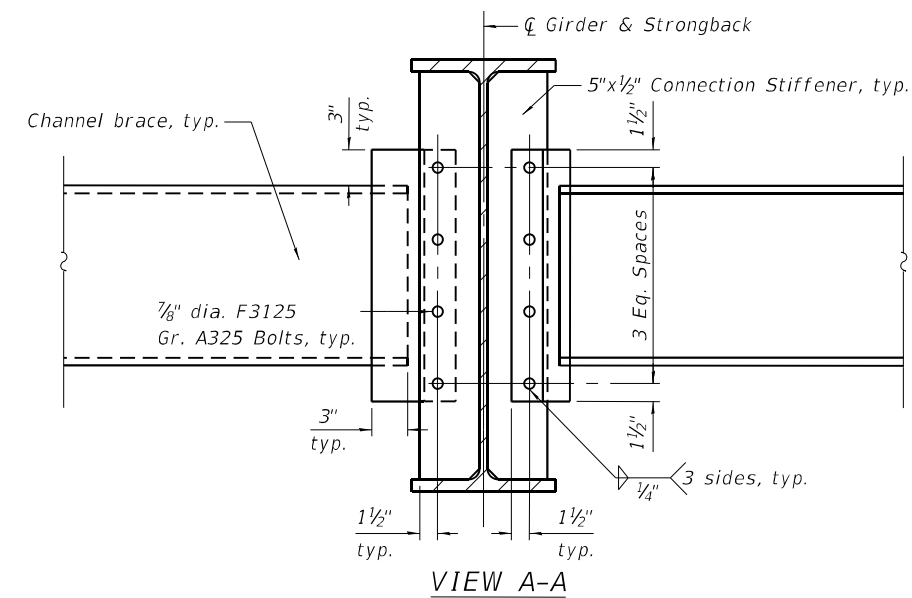

VIEW A-A

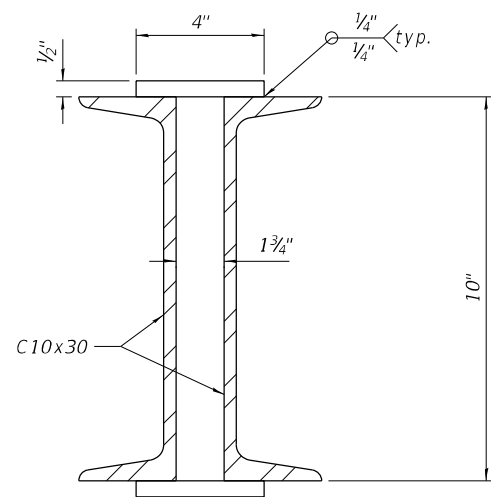

CHANNEL BRACKET

MODEL: Default
FILE NAME: Z:\1505229 B&O RR Bridge\DCN\Bridg\final\Plotsheets\0820017-76K02-103-Plat 7 - Strongback Beam Details 3.dgn

WJE ENGINEERS ARCHITECTS MATERIAL SCIENTISTS
Wiss, Janney, Elstner Associates, Inc.
330 Pfingsten Road
Northbrook, Illinois 60062
847.272.7400 tel | 847.291.9595 fax
www.wje.com

USER NAME = khill	DESIGNED - SMG/JK	REVISED -
	CHECKED - AW/RAW	REVISED -
PLOT SCALE = 0.1667"/in.	DRAWN - ACB	REVISED -
PLOT DATE = 8/13/2024	CHECKED - SMG/RAW	REVISED -

**STATE OF ILLINOIS
DEPARTMENT OF TRANSPORTATION**

**PIER 7 EB - STRONG BACK BEAM DETAILS 3
STRUCTURE NO. 082-0017**

SHEET 103 OF 114 SHEETS

F.A.I. RTE.	SECTION	COUNTY	TOTAL SHEETS	SHEET NO.
55/70	82-5VB-R-2	ST. CLAIR	254	241
CONTRACT NO. 76K02				
		ILLINOIS	FED. AID PROJECT	

MODEL: Default
 FILE NAME: Z:\1505229_B&O_RR_Bridge\DCN\Bridges\final\Plotsheets\0820017-76K02-104-Pier_9_Drainage_Detail.dgn

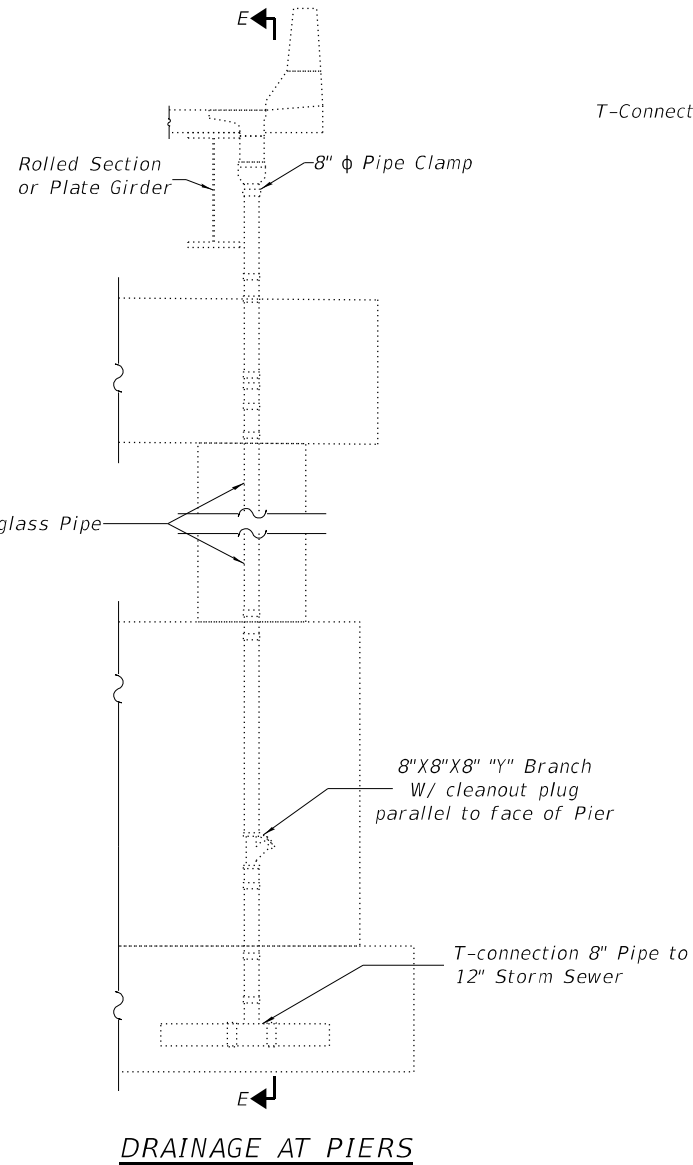
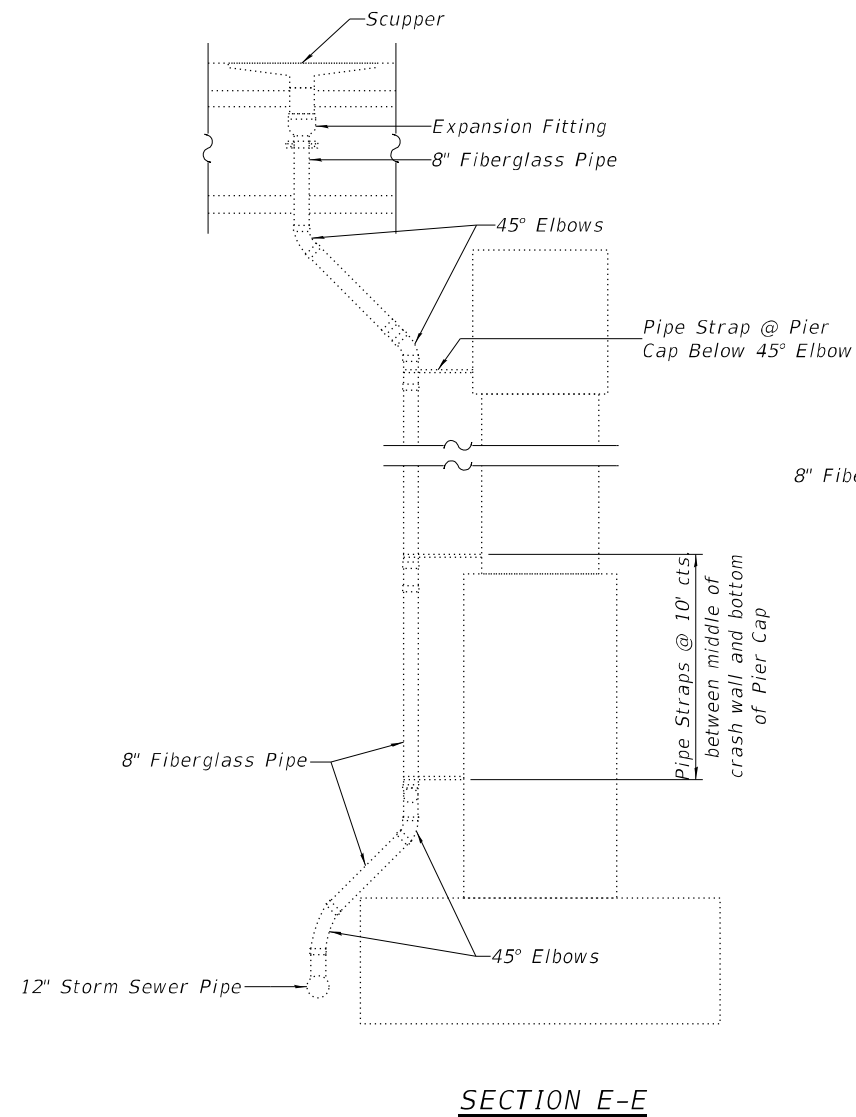

ELEVATION OF PIER 9 DRAINAGE SYSTEM

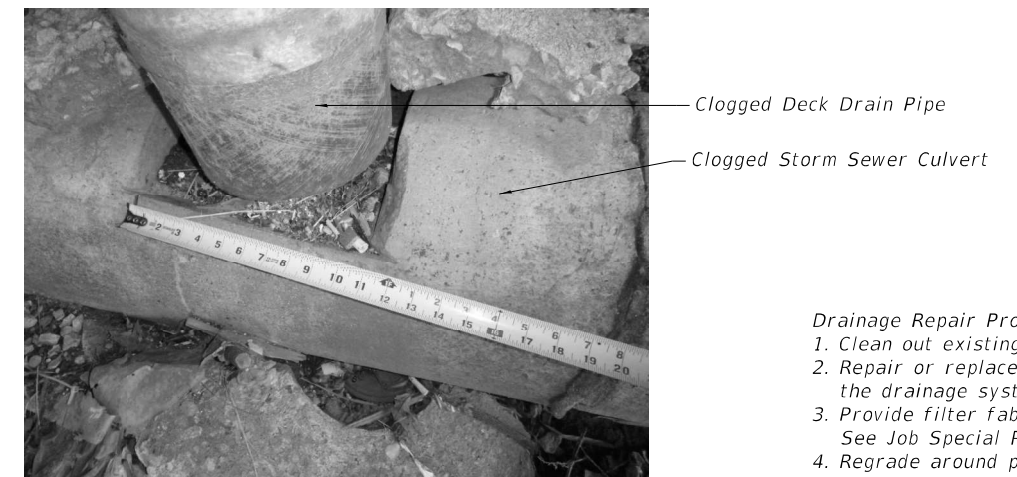

EXISTING T-CONNECTION 8" PIPE TO 12" STORM SEWER

- Drainage Repair Procedure:**
1. Clean out existing drainage system.
 2. Repair or replace any damaged portions of the drainage system.
 3. Provide filter fabric around T-Connections. See Job Special Provisions.
 4. Regrade around pier and drainage system to allow drainage away from pier footing.

BILL OF MATERIAL

ITEM	UNIT	QUANTITY
Bridge Drainage System Repair	Each	1

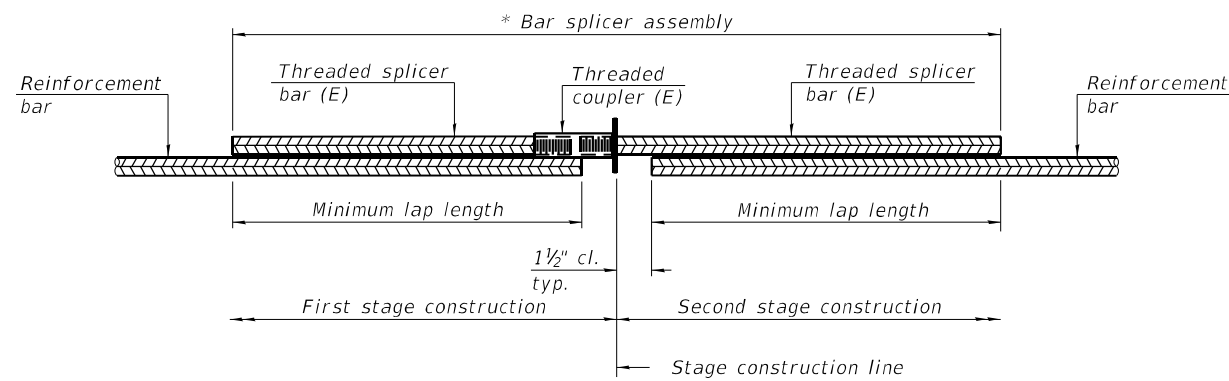

STANDARD BAR SPLICER ASSEMBLY PLAN
 (All components shall be provided from one supplier)

Threaded splicer bar length = min. lap length + 1 1/2" + thread length

* Epoxy not required on Bar Splicer Assembly components used in conjunction with black bars.

Location	Bar size	No. assemblies required	Minimum lap length
Deck (W. Abut.)	5	26	3'-6"
Deck (W. Abut.)	6	8	4'-10"
Deck (Pier 3)	5	52	3'-6"
Deck (Pier 6)	5	52	3'-6"
Deck (Pier 7)	5	52	3'-6"
Deck (Pier 8)	5	52	3'-6"
Deck (Pier 9)	5	52	3'-6"
Deck (Pier 10)	5	52	3'-6"
Deck (Pier 13)	5	52	3'-6"
Deck (Pier 16)	5	52	3'-6"
Deck (E. Abut.)	5	26	3'-6"
Deck (E. Abut.)	6	8	4'-10"
Pier 7 EB	5	5	2'-9"
Pier 7 EB	6	8	3'-4"
Pier 7 EB	8	17	5'-9"
Pier 9 EB	5	5	2'-9"
Pier 9 EB	6	8	3'-4"
Pier 9 EB	8	17	5'-9"

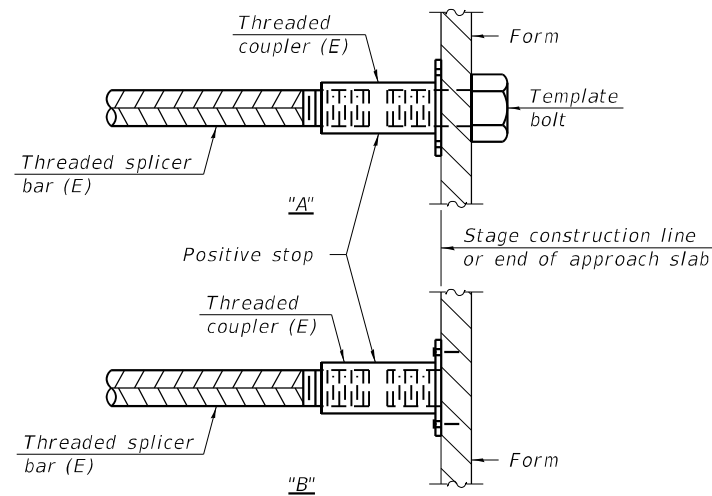

INSTALLATION AND SETTING METHODS

"A" : Set bar splicer assembly by means of a template bolt.
 "B" : Set bar splicer assembly by nailing to wood forms or cementing to steel forms.
 (E) : Indicates epoxy coating.

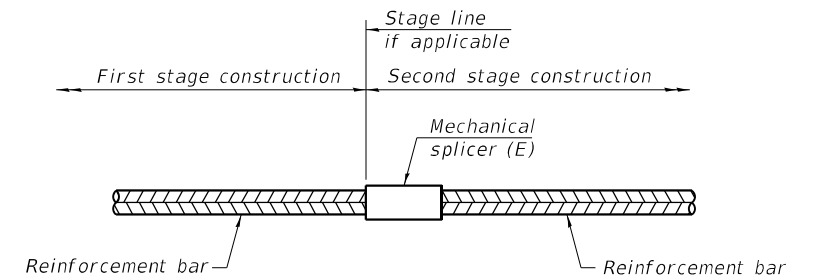

STANDARD MECHANICAL SPLICER

Location	Bar size	No. assemblies required

Notes:
 Splicer bars shall be deformed with threaded ends and have a minimum 60 ksi yield strength.
 All reinforcement shall be lapped and tied to the splicer bars.
 Bar splicer assemblies shall be epoxy coated according to the requirements for reinforcement bars. See Section 508 of the Standard Specifications.
 See approved list of bar splicer assemblies and mechanical splicers for alternatives.

BSD-1

1-1-2020

MODEL: Default
 FILE NAME: Z:\15052.29 B&O RR Bridge\DCN\Bridg\final\Plotsheets\0820017-76K02-105-Bar_Splicer.dgn

EFK•Moen
 Civil Engineering Design

USER NAME = khill	DESIGNED - ACB	REVISED -
PLOT SCALE = 0.1667"/in.	CHECKED - CDL	REVISED -
PLOT DATE = 8/13/2024	DRAWN - ACB	REVISED -
	CHECKED - CDL	REVISED -

STATE OF ILLINOIS
 DEPARTMENT OF TRANSPORTATION

BAR SPLICER ASSEMBLY AND MECHANICAL SPLICER DETAILS
 STRUCTURE NO. 082-0017

SHEET 105 OF 114 SHEETS

F.A.I. RTE.	SECTION	COUNTY	TOTAL SHEETS	SHEET NO.
55/70	82-5VB-R-2	ST. CLAIR	254	243
CONTRACT NO. 76K02				
ILLINOIS		FED. AID PROJECT		



Soil Boring Log

Route: F.A.170(I-55/I-64/US40) Structure No.: 082-0017 (Exist.) Date: 8/18/21 Page: 1 of 1
Section: 82-5VB-R-2 Description: I-55 I-70 over Railroad Yard in St. Clair County
County: St. Clair Drilling Method: HSA 3 1/4" Hammer Type: Auto SPT

Table with columns for Soil Type, Description & Observations, and U.C.S. Qu (ft), (in), (/6 in), (tsf), (%). Rows include SS-1: FILL: Brown, CLAY; ST-2: FILL: Dark gray, CLAY, with gravel and cinders; SS-3: FILL: Brown and gray, LOAM, trace brick; SS-4: FILL: Reddish brown and gray, SANDY LOAM, with gravel; SS-5: Brown, LOAM; SS-6: Brown, very fine SAND.

The U.C.S. Qu column represents the Unconfined Compressive Strength using either the IDOT Rimac Test Procedure or AASHTO 208. The Qu failure mode is indicated by B for Bulge or S for Shear. P is shown when sample disturbance only allows Penetrometer testing. The Standard Penetration Test (SPT) N value is the sum of the second and third Blows /6 in. values in each sample using AASHTO T 206.

File Name: BBS 137.docx Printed: 11/2/2021 10:45 AM BBS 137 (Rev. 01/04/2012)



Soil Boring Log

Route: F.A.170(I-55/I-64/US40) Structure No.: 082-0017 (Exist.) Date: 8/17/21 Page: 1 of 3
Section: 82-5VB-R-2 Description: I-55 I-70 over Railroad Yard in St. Clair County
County: St. Clair Drilling Method: HSA 3 1/4" and Mud Rotary Hammer Type: Auto SPT

Table with columns for Soil Type, Description & Observations, and U.C.S. Qu (ft), (in), (/6 in), (tsf), (%). Rows include SS-1: Fill: Dark gray, CLAY, trace gravel, cinders, brick fragments, and roots; SS-2: Dark gray, CLAY, trace gravel; ST-3: Dark gray, CLAY; SS-4: Gray, with brown and black, CLAY (8.5'-9.1'); Brown, fine SANDY CLAY (9.1'-10'); SS-5: Brown, SANDY LOAM; SS-6: Brown, CLAY LOAM; SS-7: Dark brown to brown, fine LOAMY SAND; SS-8: Brown, fine to medium SAND, trace coarse sand; SS-9: Brown and gray, fine to medium SAND, trace coarse sand; SS-10: Gray, fine to medium SAND, trace gravel.

The U.C.S. Qu column represents the Unconfined Compressive Strength using either the IDOT Rimac Test Procedure or AASHTO 208. The Qu failure mode is indicated by B for Bulge or S for Shear. P is shown when sample disturbance only allows Penetrometer testing. The Standard Penetration Test (SPT) N value is the sum of the second and third Blows /6 in. values in each sample using AASHTO T 206.

File Name: BBS 137.docx Printed: 11/2/2021 10:59 AM BBS 137 (Rev. 01/04/2012)



Soil Boring Log

Route: F.A.170(I-55/I-64/US40) Structure No.: 082-0017 (Exist.) Date: 8/17/21 Page: 2 of 3
Section: 82-5VB-R-2 Description: I-55 I-70 over Railroad Yard in St. Clair County
County: St. Clair Drilling Method: HSA 3 1/4" and Mud Rotary Hammer Type: Auto SPT

Table with columns for Soil Type, Description & Observations, and U.C.S. Qu (ft), (in), (/6 in), (tsf), (%). Rows include SS-11: Gray, fine SAND; SS-12: Gray, fine SAND, trace gravel; SS-13: Gray, fine SAND (53.5'-54.3') Gray, fine to coarse SAND, trace gravel (54.3' 55'); SS-14: Gray, fine SAND, trace gravel; SS-15: Gray, well-graded medium to coarse SAND; SS-16: Gray, LIMESTONE fragments, with sand.

The U.C.S. Qu column represents the Unconfined Compressive Strength using either the IDOT Rimac Test Procedure or AASHTO 208. The Qu failure mode is indicated by B for Bulge or S for Shear. P is shown when sample disturbance only allows Penetrometer testing. The Standard Penetration Test (SPT) N value is the sum of the second and third Blows /6 in. values in each sample using AASHTO T 206.

File Name: BBS 137.docx Printed: 11/2/2021 10:59 AM BBS 137 (Rev. 01/04/2012)

MODEL: Default FILE NAME: Z:\1505229_B&O_RR_Bridge\DCN\Bridg\final\Plotsheets\0820017-76K02-106-Boring_Logs.dgn



Table with columns for USER NAME, DESIGNED, CHECKED, PLOT SCALE, PLOT DATE, REVISED, and REVISIONS.

STATE OF ILLINOIS DEPARTMENT OF TRANSPORTATION

SOIL BORING LOGS STRUCTURE NO. 082-0017

SHEET 106 OF 114 SHEETS

Table with columns for F.A.I. RTE., SECTION, COUNTY, TOTAL SHEETS, SHEET NO., CONTRACT NO., ILLINOIS, FED. AID PROJECT.



Soil Boring Log

Route: F.A.170(I-55/I-64/US40) Structure No.: 082-0017 (Exist.) Date: 8/17/21 Page: 3 of 3
Section: 82-5VB-R-2 Description: I-55 I-70 over Railroad Yard in St. Clair County
County: St. Clair Drilling Method: HSA 3 1/4" and Mud Rotary Hammer Type: Auto SPT

Table with columns for Soil Type, Description & Observations, and test results (E, D, B, U, M). Includes data for SS-17 and SS-18.

The U.C.S. Qu column represents the Unconfined Compressive Strength using either the IDOT Rimac Test Procedure or AASHTO 208. The Qu failure mode is indicated by B for Bulge or S for Shear. P is shown when sample disturbance only allows Penetrometer testing. The Standard Penetration Test (SPT) N value is the sum of the second and third Blows /6 in. values in each sample using AASHTO T 206.

File Name: BBS 137.docx Printed: 11/2/2021 10:58 AM BBS 137 (Rev. 01/04/2012)



Soil Boring Log

Route: F.A.170 (I-55/I-64/US40) Structure No.: 082-0017 (Exist.) Date: 9/21/21 Page: 1 of 2
Section: 82-5VB-R-2 Description: I-55 I-70 Over Railyard in St. Clair County
County: St. Clair Drilling Method: HSA 3 1/4" and Mud Rotary Hammer Type: Auto SPT

Table with columns for Soil Type, Description & Observations, and test results (E, D, B, U, M). Includes data for SS-1, SS-2, ST-3, SS-4, ST-5, SS-6, SS-7, SS-8, SS-9, and SS-10.

The U.C.S. Qu column represents the Unconfined Compressive Strength using either the IDOT Rimac Test Procedure or AASHTO 208. The Qu failure mode is indicated by B for Bulge or S for Shear. P is shown when sample disturbance only allows Penetrometer testing. The Standard Penetration Test (SPT) N value is the sum of the second and third Blows /6 in. values in each sample using AASHTO T 206.

File Name: BBS 137.docx Printed: 11/2/2021 10:53 AM BBS 137 (Rev. 01/04/2012)



Soil Boring Log

Route: F.A.170 (I-55/I-64/US40) Structure No.: 082-0017 (Exist.) Date: 9/21/21 Page: 2 of 2
Section: 82-5VB-R-2 Description: I-55 I-70 Over Railyard in St. Clair County
County: St. Clair Drilling Method: HSA 3 1/4" and Mud Rotary Hammer Type: Auto SPT

Table with columns for Soil Type, Description & Observations, and test results (E, D, B, U, M). Includes data for SS-11, SS-12, SS-13, and SS-14.

The U.C.S. Qu column represents the Unconfined Compressive Strength using either the IDOT Rimac Test Procedure or AASHTO 208. The Qu failure mode is indicated by B for Bulge or S for Shear. P is shown when sample disturbance only allows Penetrometer testing. The Standard Penetration Test (SPT) N value is the sum of the second and third Blows /6 in. values in each sample using AASHTO T 206.

File Name: BBS 137.docx Printed: 11/2/2021 10:53 AM BBS 137 (Rev. 01/04/2012)

MODEL: Default FILE NAME: Z:\15052229_B&O_RR_Bridge\DCN\Bridg\final\Plotsheets\0820017-76K02-107-Boring_Logs.dgn

Table with columns for USER NAME, DESIGNED, CHECKED, PLOT SCALE, PLOT DATE, and REVISIONS.

STATE OF ILLINOIS DEPARTMENT OF TRANSPORTATION

SOIL BORING LOGS STRUCTURE NO. 082-0017 SHEET 107 OF 114 SHEETS

Table with columns for F.A.I. RTE., SECTION, COUNTY, TOTAL SHEETS, SHEET NO., and CONTRACT NO.



Soil Boring Log

Route: F.A.170 (I-55/I-64/US40) Structure No.: 082-0017 (Exist.) Date: 9/20/21 Page: 1 of 1

Section: 82-5VB-R-2 Description: I-55 I-70 Over Railyard in St. Clair County

County: St. Clair Drilling Method: HSA 3 1/4" Hammer Type: Auto SPT

Boring No.: B-2S Logged by: J. Urton

Station: 77+56.51 Offset: 88.16 Latitude: N38°38'13.25899" Longitude: W90°08'11.41976" Ground Surface El.: 422.55 ft

Table with columns for Soil Type, Description & Observations, and SPT data (E, D, B, U, M). Rows include SS-1: FILL: Brown, CLAY; SS-2: FILL: Gray, SAND; SS-3: FILL: Brown and gray, SILTY CLAY; ST-4: FILL: Dark gray, CLAY; SS-5: Dark gray and brown, CLAY, sand lenses present at the bottom of sampler; SS-6: Brown, CLAY.

Boring terminated at 20.0 ft. (402.55) -20

The U.C.S. Qu column represents the Unconfined Compressive Strength using either the IDOT Rimac Test Procedure or AASHTO 208. The Qu failure mode is indicated by B for Bulge or S for Shear. P is shown when sample disturbance only allows Penetrometer testing. The Standard Penetration Test (SPT) N value is the sum of the second and third Blows /6 in. values in each sample using AASHTO T 206.

File Name: BBS 137.docx Printed: 11/2/2021 10:46 AM BBS 137 (Rev. 01/04/2012)



Soil Boring Log

Route: F.A.170 (I-55/I-64/US40) Structure No.: 082-0017 (Exist.) Date: 9/29/21 Page: 1 of 2

Section: 82-5VB-R-2 Description: I-55 I-70 Over Railroad Yard in St. Clair County

County: St. Clair Drilling Method: HSA 3 1/4" and Mud Rotary Hammer Type: Auto SPT

Boring No.: B-2.5 Logged by: J. Urton

Station: 78+71.77 Offset: -0.87 Latitude: N38°38'14.69592" Longitude: W90°08'11.53205" Ground Surface El.: 415.65 ft

Table with columns for Soil Type, Description & Observations, and SPT data (E, D, B, U, M). Rows include SS-1: FILL: Black, CINDERS, trace glass, gravel and sand; SS-2: FILL: Black, CINDERS, trace glass, gravel and sand; SS-3: FILL: Black, CINDERS, trace glass, gravel and sand (6.0'-6.3') (409.35); ST-4: FILL: Brown, CLAY; SS-5: Dark gray, CLAY (13.5'-13.8'); SS-6: Brown, CLAY; SS-7: Brown, fine SAND (23.5'-24.1'); SS-8: Dark gray, fine SAND; SS-9: Brown, LOAMY SAND (33.5'-33.8'); SS-10: Dark gray, fine SAND; SS-11: Dark gray, fine SAND; SS-12: Dark gray, LOAMY SAND; SS-13: Dark gray, fine SAND; SS-14: Dark gray, fine SAND, trace medium and coarse sand.

Boring terminated at 60.0 ft. (355.65) -60

The U.C.S. Qu column represents the Unconfined Compressive Strength using either the IDOT Rimac Test Procedure or AASHTO 208. The Qu failure mode is indicated by B for Bulge or S for Shear. P is shown when sample disturbance only allows Penetrometer testing. The Standard Penetration Test (SPT) N value is the sum of the second and third Blows /6 in. values in each sample using AASHTO T 206.

File Name: BBS 137.docx Printed: 11/2/2021 11:11 AM BBS 137 (Rev. 01/04/2012)



Soil Boring Log

Route: F.A.170 (I-55/I-64/US40) Structure No.: 082-0017 (Exist.) Date: 9/29/21 Page: 2 of 2

Section: 82-5VB-R-2 Description: I-55 I-70 Over Railroad Yard in St. Clair County

County: St. Clair Drilling Method: HSA 3 1/4" and Mud Rotary Hammer Type: Auto SPT

Boring No.: B-2.5 Logged by: J. Urton

Station: 78+71.77 Offset: -0.87 Latitude: N38°38'14.69592" Longitude: W90°08'11.53205" Ground Surface El.: 415.65 ft

Table with columns for Soil Type, Description & Observations, and SPT data (E, D, B, U, M). Rows include SS-11: Dark gray, fine SAND; SS-12: Dark gray, LOAMY SAND; SS-13: Dark gray, fine SAND; SS-14: Dark gray, fine SAND, trace medium and coarse sand.

Boring terminated at 60.0 ft. (355.65) -60

The U.C.S. Qu column represents the Unconfined Compressive Strength using either the IDOT Rimac Test Procedure or AASHTO 208. The Qu failure mode is indicated by B for Bulge or S for Shear. P is shown when sample disturbance only allows Penetrometer testing. The Standard Penetration Test (SPT) N value is the sum of the second and third Blows /6 in. values in each sample using AASHTO T 206.

File Name: BBS 137.docx Printed: 11/2/2021 11:04 AM BBS 137 (Rev. 01/04/2012)

MODEL: Default FILE NAME: Z:\1505229_B&O_RR_Bridge\DCN\Bridg\final\PlotSheets\0820017-76K02-108-Boring_Logs.dgn



Table with columns for USER NAME, DESIGNED, CHECKED, PLOT SCALE, PLOT DATE, REVISED, and DRAWN.

STATE OF ILLINOIS DEPARTMENT OF TRANSPORTATION

SOIL BORING LOGS STRUCTURE NO. 082-0017 SHEET 108 OF 114 SHEETS

Table with columns for F.A.I. RTE., SECTION, COUNTY, TOTAL SHEETS, SHEET NO., CONTRACT NO., ILLINOIS, FED. AID PROJECT.



Soil Boring Log

Route: F.A.170 (I-55/I-64/US40) Structure No.: 082-0017 (Exist.) Date: 9/29/21 Page: 1 of 1
Section: 82-5VB-R-2 Description: I-55 I-70 Over Railroad Yard in St. Clair County
County: St. Clair Drilling Method: HSA 3 1/4" Hammer Type: Auto SPT

Table with columns for Soil Type, Description & Observations, and Unconfined Compressive Strength (U.C.S.) values. Includes data for samples SS-1 through SS-6.

The U.C.S. Qu column represents the Unconfined Compressive Strength using either the IDOT Rimac Test Procedure or AASHTO 208. The Qu failure mode is indicated by B for Bulge or S for Shear. P is shown when sample disturbance only allows Penetrometer testing.

File Name: BBS 137.docx Printed: 11/2/2021 10:31 AM BBS 137 (Rev. 01/04/2012)



Soil Boring Log

Route: F.A.170 (I-55/I-64/US40) Structure No.: 082-0017 (Exist.) Date: 9/28/21 Page: 1 of 3
Section: 82-5VB-R-2 Description: I-55 I-70 Over Railroad Yard in St. Clair County
County: St. Clair Drilling Method: HSA 3 1/4" and Mud Rotary Hammer Type: Auto SPT

Table with columns for Soil Type, Description & Observations, and Unconfined Compressive Strength (U.C.S.) values. Includes data for samples SS-1 through SS-6 and ST-3 through ST-5.

The U.C.S. Qu column represents the Unconfined Compressive Strength using either the IDOT Rimac Test Procedure or AASHTO 208. The Qu failure mode is indicated by B for Bulge or S for Shear. P is shown when sample disturbance only allows Penetrometer testing.

File Name: BBS 137.docx Printed: 11/2/2021 10:12 AM BBS 137 (Rev. 01/04/2012)



Soil Boring Log

Route: F.A.170(I-55/I-64/US40) Structure No.: 082-0017 (Exist.) Date: 9/28/21 Page: 2 of 3
Section: 82-5VB-R-2 Description: I-55 I-70 Over Railroad Yard in St. Clair County
County: St. Clair Drilling Method: HSA 3 1/4" and Mud Rotary Hammer Type: Auto SPT

Table with columns for Soil Type, Description & Observations, and Unconfined Compressive Strength (U.C.S.) values. Includes data for samples SS-7 through SS-17.

The U.C.S. Qu column represents the Unconfined Compressive Strength using either the IDOT Rimac Test Procedure or AASHTO 208. The Qu failure mode is indicated by B for Bulge or S for Shear. P is shown when sample disturbance only allows Penetrometer testing.

File Name: BBS 137.docx Printed: 11/2/2021 10:13 AM BBS 137 (Rev. 01/04/2012)

MODEL: Default FILE NAME: Z:\15052229_B&O_RR_Bridge\DCN\Bridg\final\PlotSheets\0820017-76K02-109-Boring_Logs.dgn



Table with columns for USER NAME, DESIGNED, CHECKED, PLOT SCALE, PLOT DATE, and REVISIONS.

STATE OF ILLINOIS DEPARTMENT OF TRANSPORTATION

SOIL BORING LOGS STRUCTURE NO. 082-0017

Table with columns for F.A.I. RTE., SECTION, COUNTY, TOTAL SHEETS, SHEET NO., and CONTRACT NO.



Soil Boring Log

Route: F.A.170 (I-55/I-64/US40) Structure No.: 082-0017 (Exist.) Date: 9/28/21 Page: 3 of 3
Section: 85-5VB-R-2 Description: I-55 I-70 Over Railroad Yard in St. Clair County
County: St. Clair Drilling Method: HSA 3 1/4" and Mud Rotary Hammer Type: Auto SPT

Boring No.: B-3S Logged by: J. Urton
Station: 79+72.88
Offset: 77.62
Latitude: N38°38'15.08697"
Longitude: W90°08'09.99794"
Ground Surface El.: 414.52 ft

Table with columns for Soil Type, Description & Observations, and U.C.S. parameters (E, D, B, U, M). Includes data for SS-18 and SS-19.

The U.C.S. Qu column represents the Unconfined Compressive Strength using either the IDOT Rimac Test Procedure or AASHTO 208. The Qu failure mode is indicated by B for Bulge or S for Shear. P is shown when sample disturbance only allows Penetrometer testing. The Standard Penetration Test (SPT) N value is the sum of the second and third Blows /6 in. values in each sample using AASHTO T 206.

File Name: BBS 137.docx Printed: 11/2/2021 10:14 AM BBS 137 (Rev. 01/04/2012)



Soil Boring Log

Route: F.A.170 (I-55/I-64/US40) Structure No.: 082-0017 (Exist.) Date: 8/25/21 Page: 1 of 2
Section: 82-5VB-R-2 Description: I-55 I-70 over Railroad Yard in St. Clair County
County: St. Clair Drilling Method: HSA 3 1/4" and Mud Rotary Hammer Type: Auto SPT

Boring No.: B-3.5 Logged by: J. Urton
Station: 81+04.54
Offset: -6.07
Latitude: N38°38'16.62834"
Longitude: W90°08'09.93853"
Ground Surface El.: 410.34 ft

Table with columns for Soil Type, Description & Observations, and U.C.S. parameters (E, D, B, U, M). Includes data for SS-1, SS-2, SS-3, ST-4, SS-5, SS-6, SS-7, SS-8, SS-9, and SS-10.

The U.C.S. Qu column represents the Unconfined Compressive Strength using either the IDOT Rimac Test Procedure or AASHTO 208. The Qu failure mode is indicated by B for Bulge or S for Shear. P is shown when sample disturbance only allows Penetrometer testing. The Standard Penetration Test (SPT) N value is the sum of the second and third Blows /6 in. values in each sample using AASHTO T 206.

File Name: BBS 137.docx Printed: 11/2/2021 10:36 AM BBS 137 (Rev. 01/04/2012)



Soil Boring Log

Route: F.A.170 (I-55/I-64/US40) Structure No.: 082-0017 (Exist.) Date: 8/25/21 Page: 2 of 2
Section: 82-5VB-R-2 Description: I-55 I-70 over Railroad Yard in St. Clair County
County: St. Clair Drilling Method: HSA 3 1/4" and Mud Rotary Hammer Type: Auto SPT

Boring No.: B-3.5 Logged by: J. Urton
Station: 81+04.54
Offset: -6.07
Latitude: N38°38'16.62834"
Longitude: W90°08'09.93853"
Ground Surface El.: 410.34 ft

Table with columns for Soil Type, Description & Observations, and U.C.S. parameters (E, D, B, U, M). Includes data for SS-11, SS-12, SS-13, and SS-14.

The U.C.S. Qu column represents the Unconfined Compressive Strength using either the IDOT Rimac Test Procedure or AASHTO 208. The Qu failure mode is indicated by B for Bulge or S for Shear. P is shown when sample disturbance only allows Penetrometer testing. The Standard Penetration Test (SPT) N value is the sum of the second and third Blows /6 in. values in each sample using AASHTO T 206.

File Name: BBS 137.docx Printed: 11/2/2021 10:40 AM BBS 137 (Rev. 01/04/2012)

MODEL: Default FILE NAME: Z:\1505229_B&O_RR_Bridge\DCN\Bridg\final\Plotsheets\0820017-76K02-110-Boring_Logs.dgn



Table with columns for USER NAME, DESIGNED, CHECKED, PLOT SCALE, PLOT DATE, and REVISIONS.

STATE OF ILLINOIS DEPARTMENT OF TRANSPORTATION

SOIL BORING LOGS STRUCTURE NO. 082-0017 SHEET 110 OF 114 SHEETS

Table with columns for F.A.I. RTE., SECTION, COUNTY, TOTAL SHEETS, SHEET NO., and CONTRACT NO.



Soil Boring Log

Route: F.A.170 (I-55/I-64/US40) Structure No.: 082-0017 (Exist.) Date: 8/16/21 Page: 1 of 2
Section: 82-5VB-R-2 Description: I-55 I-70 Over Railroad Yard in St. Clair County
County: St. Clair Drilling Method: HSA 3 1/4" and Mud Rotary Hammer Type: Auto SPT

Boring No.: B-4N Logged by: Shawn Abrahamsen
Station: 81+40.08
Offset: -71.27
Latitude: N38°38'17.28093"
Longitude: W90°08'10.36679"
Ground Surface El.: 407.90 ft

Table with columns for Soil Type, Description & Observations, and Unconfined Compressive Strength (Qu) in (ft), (/6 in), (tsf), and (%). Rows include SS-1 to SS-6 with various soil descriptions like 'Brown and gray, CLAY, with gravel' and 'Brown, SAND'.

The U.C.S. Qu column represents the Unconfined Compressive Strength using either the IDOT Rimac Test Procedure or AASHTO 208. The Qu failure mode is indicated by B for Bulge or S for Shear. P is shown when sample disturbance only allows Penetrometer testing. The Standard Penetration Test (SPT) N value is the sum of the second and third Blows /6 in. values in each sample using AASHTO T 206.

File Name: BBS 137.docx Printed: 11/2/2021 9:37 AM BBS 137 (Rev. 01/04/2012)



Soil Boring Log

Route: F.A.170 (I-55/I-64/US40) Structure No.: (Exist.) Date: 8/16/21 Page: 2 of 2
Section: 82-5VB-R-2 Description: I-55 I-70 Over Railroad Yard in St. Clair County
County: St. Clair Drilling Method: HSA 3 1/4" and Mud Rotary Hammer Type: Auto SPT

Boring No.: B-4N Logged by: Shawn Abrahamsen
Station: 81+40.08
Offset: -71.27
Latitude: N38°38'17.28093"
Longitude: W90°08'10.36679"
Ground Surface El.: 407.90 ft

Table with columns for Soil Type, Description & Observations, and Unconfined Compressive Strength (Qu) in (ft), (/6 in), (tsf), and (%). Rows include SS-11 to SS-14 with various soil descriptions like 'Gray, CLAY' and 'Brown, SAND'.

The U.C.S. Qu column represents the Unconfined Compressive Strength using either the IDOT Rimac Test Procedure or AASHTO 208. The Qu failure mode is indicated by B for Bulge or S for Shear. P is shown when sample disturbance only allows Penetrometer testing. The Standard Penetration Test (SPT) N value is the sum of the second and third Blows /6 in. values in each sample using AASHTO T 206.

File Name: BBS 137.docx Printed: 11/2/2021 9:35 AM BBS 137 (Rev. 01/04/2012)



Soil Boring Log

Route: F.A.170 (I-55/I-64/US40) Structure No.: 082-0017 (Exist.) Date: 8/12/21 Page: 1 of 1
Section: 82-5VB-R-2 Description: I-55 I-70 over Railroad Yard in St. Clair County
County: St. Clair Drilling Method: HSA 3 1/4" Hammer Type: Auto SPT

Boring No.: B-4S Logged by: J. Urton
Station: 81+74.75
Offset: 72.84
Latitude: N38°38'16.76434"
Longitude: W90°08'08.61872"
Ground Surface El.: 408.82 ft

Table with columns for Soil Type, Description & Observations, and Unconfined Compressive Strength (Qu) in (ft), (/6 in), (tsf), and (%). Rows include SS-1 to SS-6 with various soil descriptions like 'Dark brown, CLAY, with gravel' and 'Dark gray and brown, CLAY'.

The U.C.S. Qu column represents the Unconfined Compressive Strength using either the IDOT Rimac Test Procedure or AASHTO 208. The Qu failure mode is indicated by B for Bulge or S for Shear. P is shown when sample disturbance only allows Penetrometer testing. The Standard Penetration Test (SPT) N value is the sum of the second and third Blows /6 in. values in each sample using AASHTO T 206.

File Name: BBS 137.docx Printed: 11/2/2021 2:13 PM BBS 137 (Rev. 01/04/2012)

MODEL: Default FILE NAME: Z:\15052229_B&O_RR_Bridge\DCN\Bridges\final\Plotsheets\0820017-76K02-111-Boring_Logs.dgn



Table with columns for USER NAME, DESIGNED, CHECKED, PLOT SCALE, PLOT DATE, and REVISIONS.

STATE OF ILLINOIS DEPARTMENT OF TRANSPORTATION

SOIL BORING LOGS STRUCTURE NO. 082-0017 SHEET 111 OF 114 SHEETS

Table with columns for F.A.I. RTE., SECTION, COUNTY, TOTAL SHEETS, SHEET NO., and CONTRACT NO.



Soil Boring Log

Route: F.A.170 (I-55/I-64/US40) Structure No.: 082-0017 (Exist.) Date: 8/11/21 Page: 1 of 1
Section: 82-5VB-R-2 Description: I-55 I-70 over Railroad Yard in St. Clair County
County: St. Clair Drilling Method: HSA 3 1/4" Hammer Type: Auto SPT

Table with columns for Soil Type, Description & Observations, and Unconfined Compressive Strength (U.C.S.) parameters (E, D, B, U, M) in various units (ft, in, tsf, %).

The U.C.S. Qu column represents the Unconfined Compressive Strength using either the IDOT Rimac Test Procedure or AASHTO 208. The Qu failure mode is indicated by B for Bulge or S for Shear. P is shown when sample disturbance only allows Penetrometer testing. The Standard Penetration Test (SPT) N value is the sum of the second and third Blows /6 in. values in each sample using AASHTO T 206.

File Name: BBS 137.docx Printed: 11/2/2021 9:30 AM BBS 137 (Rev. 01/04/2012)



Soil Boring Log

Route: F.A.170 (I-55/I-64/US40) Structure No.: 082-0017 (Exist.) Date: 8/18/21 Page: 1 of 3
Section: 82-5VB-R-2 Description: I-55 I-70 over Railroad Yard in St. Clair County
County: St. Clair Drilling Method: HSA 3 1/4" and Mud Rotary Hammer Type: Auto SPT

Table with columns for Soil Type, Description & Observations, and Unconfined Compressive Strength (U.C.S.) parameters (E, D, B, U, M) in various units (ft, in, tsf, %).

The U.C.S. Qu column represents the Unconfined Compressive Strength using either the IDOT Rimac Test Procedure or AASHTO 208. The Qu failure mode is indicated by B for Bulge or S for Shear. P is shown when sample disturbance only allows Penetrometer testing. The Standard Penetration Test (SPT) N value is the sum of the second and third Blows /6 in. values in each sample using AASHTO T 206.

File Name: BBS 137.docx Printed: 11/2/2021 9:21 AM BBS 137 (Rev. 01/04/2012)



Soil Boring Log

Route: F.A.170 (I-55/I-64/US40) Structure No.: 082-0017 (Exist.) Date: 8/19/21 Page: 2 of 3
Section: 82-5VB-R-2 Description: I-55 I-70 over Railroad Yard in St. Clair County
County: St. Clair Drilling Method: HSA 3 1/4" and Mud Rotary Hammer Type: Auto SPT

Table with columns for Soil Type, Description & Observations, and Unconfined Compressive Strength (U.C.S.) parameters (E, D, B, U, M) in various units (ft, in, tsf, %).

The U.C.S. Qu column represents the Unconfined Compressive Strength using either the IDOT Rimac Test Procedure or AASHTO 208. The Qu failure mode is indicated by B for Bulge or S for Shear. P is shown when sample disturbance only allows Penetrometer testing. The Standard Penetration Test (SPT) N value is the sum of the second and third Blows /6 in. values in each sample using AASHTO T 206.

File Name: BBS 137.docx Printed: 11/2/2021 9:22 AM BBS 137 (Rev. 01/04/2012)

MODEL: Default FILE NAME: Z:\15052229_B&O_RR_Bridge\DCN\Bridges\final\Plotsheets\0820017-76K02-112-Boring_Logs.dgn



Table with columns for USER NAME, DESIGNED, CHECKED, PLOT SCALE, PLOT DATE, REVISED, and CHECKED.

STATE OF ILLINOIS DEPARTMENT OF TRANSPORTATION

SOIL BORING LOGS STRUCTURE NO. 082-0017

Table with columns for F.A.I. RTE., SECTION, COUNTY, TOTAL SHEETS, SHEET NO., and CONTRACT NO.



Soil Boring Log

Route: F.A.170 (I-55/I-64/US40) Structure No.: 082-0017 (Exist.) Date: 8/20/21 Page: 3 of 3
Section: 82-5VB-R-2 Description: I-55 I-70 over Railroad Yard in St. Clair County
County: St. Clair Drilling Method: HSA 3 1/4" and Mud Rotary Hammer Type: Auto SPT

Boring No.: B-5S Logged by: J. Urton
Station: 84+45.67
Offset: 73.93
Latitude: N38°38'18.97370"
Longitude: W90°08'06.68945"
Ground Surface El.: 404.45 ft

Table with columns for Soil Type, Description & Observations, and U.C.S. Qu. T. (ft), (ft), /6 in., (tsf), (%). Rows include SS-19: Gray, well-graded SAND; SS-20: Gray, fine SAND, trace gravel; SS-21: Gray, fine to medium SAND, trace coarse sand and gravel; SS-22: Gray, well-graded SAND, with gravel.

The U.C.S. Qu column represents the Unconfined Compressive Strength using either the IDOT Rimac Test Procedure or AASHTO 208. The Qu failure mode is indicated by B for Bulge or S for Shear. P is shown when sample disturbance only allows Penetrometer testing. The Standard Penetration Test (SPT) N value is the sum of the second and third Blows /6 in. values in each sample using AASHTO T 206.

File Name: BBS 137.docx Printed: 11/2/2021 9:24 AM BBS 137 (Rev. 01/04/2012)



Soil Boring Log

Route: F.A.170 (I-55/I-64/US40) Structure No.: 082-0017 (Exist.) Date: 8/12/21 Page: 1 of 2
Section: 82-5VB-R-2 Description: I-55 I-70 Over Railroad Yard in St. Clair County
County: St. Clair Drilling Method: HSA 3 1/4" and Mud Rotary Hammer Type: Auto SPT

Boring No.: B-6N Logged by: S. Abrahamsen
Station: 86+96.41
Offset: -70.21
Latitude: N38°38'21.82453"
Longitude: W90°08'06.41735"
Ground Surface El.: 409.01 ft

Table with columns for Soil Type, Description & Observations, and U.C.S. Qu. T. (ft), (ft), /6 in., (tsf), (%). Rows include SS-1: FILL: Brown, CLAY, trace gravel and glass; SS-2: FILL: Brown and gray, CLAY, trace glass and plastic (3.5'-4'); SS-3: FILL: Brown and gray, SILTY LOAM (6'-6.9'); SS-4: Gray, CLAY, trace gravel; SS-5: Brown, CLAY LOAM; SS-6: Gray, CLAY, trace gravel (13.5'-13.67'); SS-7: Gray, CLAY LOAM (18.5'-19.5); SS-8: Gray, CLAY LOAM; SS-9: Gray, CLAY; SS-10: Gray, CLAY; SS-11: Gray, CLAY.

The U.C.S. Qu column represents the Unconfined Compressive Strength using either the IDOT Rimac Test Procedure or AASHTO 208. The Qu failure mode is indicated by B for Bulge or S for Shear. P is shown when sample disturbance only allows Penetrometer testing. The Standard Penetration Test (SPT) N value is the sum of the second and third Blows /6 in. values in each sample using AASHTO T 206.

File Name: BBS 137.docx Printed: 11/2/2021 9:05 AM BBS 137 (Rev. 01/04/2012)



Soil Boring Log

Route: F.A.170 (I-55/I-64/US40) Structure No.: 082-0017 (Exist.) Date: 8/12/21 Page: 2 of 2
Section: 82-5VB-R-2 Description: I-55 I-70 Over Railroad Yard in St. Clair County
County: St. Clair Drilling Method: HSA 3 1/4" and Mud Rotary Hammer Type: Auto SPT

Boring No.: B-6N Logged by: Shawn Abrahamsen
Station: 86+91.75
Offset: 74.80
Latitude: N38°38'21.82453"
Longitude: W90°08'06.41735"
Ground Surface El.: 409.01 ft

Table with columns for Soil Type, Description & Observations, and U.C.S. Qu. T. (ft), (ft), /6 in., (tsf), (%). Rows include SS-12: Gray, SAND, trace gravel; SS-13: Gray, SAND; SS-14: Gray, SAND, trace gravel; SS-15: Gray, SANDY LOAM, trace gravel.

The U.C.S. Qu column represents the Unconfined Compressive Strength using either the IDOT Rimac Test Procedure or AASHTO 208. The Qu failure mode is indicated by B for Bulge or S for Shear. P is shown when sample disturbance only allows Penetrometer testing. The Standard Penetration Test (SPT) N value is the sum of the second and third Blows /6 in. values in each sample using AASHTO T 206.

File Name: BBS 137.docx Printed: 11/2/2021 9:12 AM BBS 137 (Rev. 01/04/2012)

MODEL: Default FILE NAME: Z:\15052229_B&O_RR_Bridge\DCN\Bridg\final\Plotsheets\0820017-76K02-113-Boring_Logs.dgn



Table with columns for USER NAME, DESIGNED, CHECKED, PLOT SCALE, PLOT DATE, REVISED, and DRAWN.

STATE OF ILLINOIS DEPARTMENT OF TRANSPORTATION

SOIL BORING LOGS STRUCTURE NO. 082-0017

Table with columns for F.A.I. RTE., SECTION, COUNTY, TOTAL SHEETS, SHEET NO., and CONTRACT NO.



Soil Boring Log

Route: F.A.170 (I-55/I-64/US40) Structure No.: 082-0017 (Exist.) Date: _____ Page: 1 of 1
 Section: 82-5VB-R-2 Description: I-55 I-70 Over Railroad Yard in St. Clair County
 County: St. Clair Drilling Method: HSA 3 1/4" Hammer Type: Auto SPT

Boring No.: B-6S Logged by: J. Urton

Station: 86+96.41
 Offset: -70.21
 Latitude: N38°38'20.98122"
 Longitude: W90°08'04.93834"
 Ground Surface El.: 407.26 ft

Surface Water Elev.: _____ ft
 Groundwater Elev.: _____ ft
 First Encounter: 402.3 ft
 Upon Completion: _____ ft
 After 336 Hours 403.0 ft

Soil Type, Description & Observations	E L E V. (ft)	D E P T H (ft)	B L O W S (/6 in)	U. C. S. Qu (tsf)	M O I S T. (%)	Soil Type, Description & Observations	E L E V. (ft)	D E P T H (ft)	B L O W S (/6 in)	U. C. S. Qu (tsf)	M O I S T. (%)
SS-1: FILL: Brown, SILTY LOAM, with gravel			7	2.5	4.4						
			7	P							
			4								
SS-2: FILL: Dark gray, SILTY LOAM, with gravel			22	2.75	8.2						
			42	P							
			17								
(401.80)											
SS-3: FILL: Dark brown, SANDY CLAY			11	2.75	15.4						
			12	P							
			2								
(399.30)											
SS-4: Gray, CLAY			WH	1.25	30.8						
			WH	P							
			WH								
(305.30)											
ST-5: Gray, CLAY LOAM			-	0.75	30.8						
			-	P							
			-								
(390.30)											
SS-6: Gray, SILTY CLAY, trace gravel			WH	0.75	38.3						
			WH	P							
			WH								
Boring terminated at 20.0 ft. (387.30)			20								

The U.C.S. Qu column represents the Unconfined Compressive Strength using either the IDOT Rimac Test Procedure or AASHTO 208.
 The Qu failure mode is indicated by B for Bulge or S for Shear. P is shown when sample disturbance only allows Penetrometer testing.
 The Standard Penetration Test (SPT) N value is the sum of the second and third Blows /6 in. values in each sample using AASHTO T 206.

File Name: BBS 137.docx

Printed: 11/2/2021 8:43 AM

BBS 137 (Rev. 01/04/2012)

MODEL: Default
 FILE NAME: Z:\1505229_B&O_RR_Bridge\DCN\Bridg\final\Plotsheets\0820017-76K02-114-Boring_Logs.dgn



USER NAME = khill	DESIGNED - ACB	REVISED -
	CHECKED - CDL	REVISED -
PLOT SCALE = 0.1667"/in.	DRAWN - ACB	REVISED -
PLOT DATE = 8/13/2024	CHECKED - CDL	REVISED -

**STATE OF ILLINOIS
 DEPARTMENT OF TRANSPORTATION**

**SOIL BORING LOGS
 STRUCTURE NO. 082-0017**

SHEET 114 OF 114 SHEETS

F.A.I. RTE.	SECTION	COUNTY	TOTAL SHEETS	SHEET NO.
55/70	82-5VB-R-2	ST. CLAIR	254	252
CONTRACT NO. 76K02				
		ILLINOIS	FED. AID PROJECT	

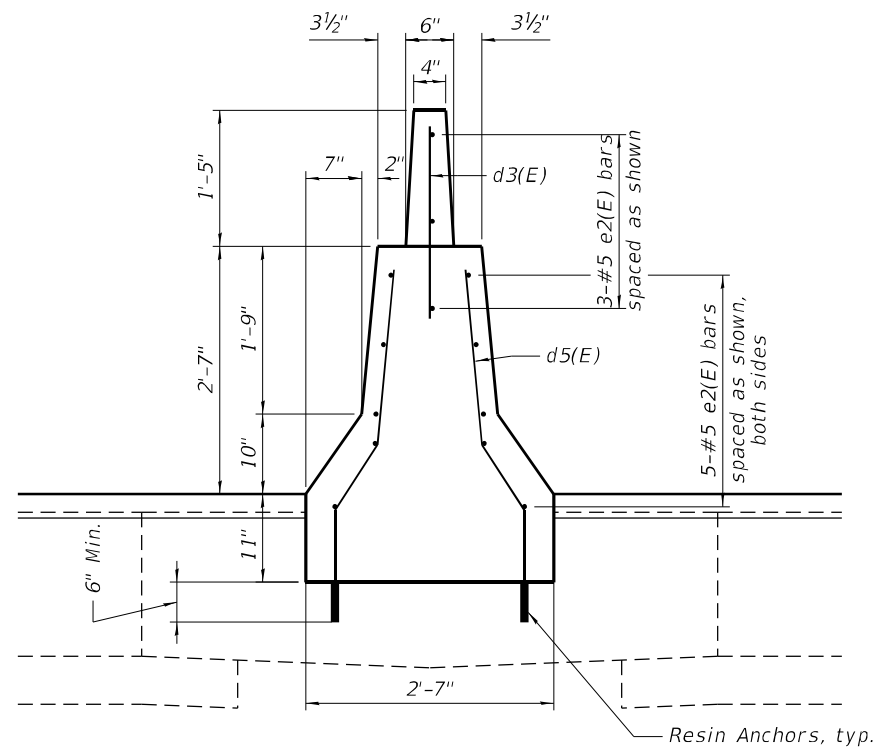
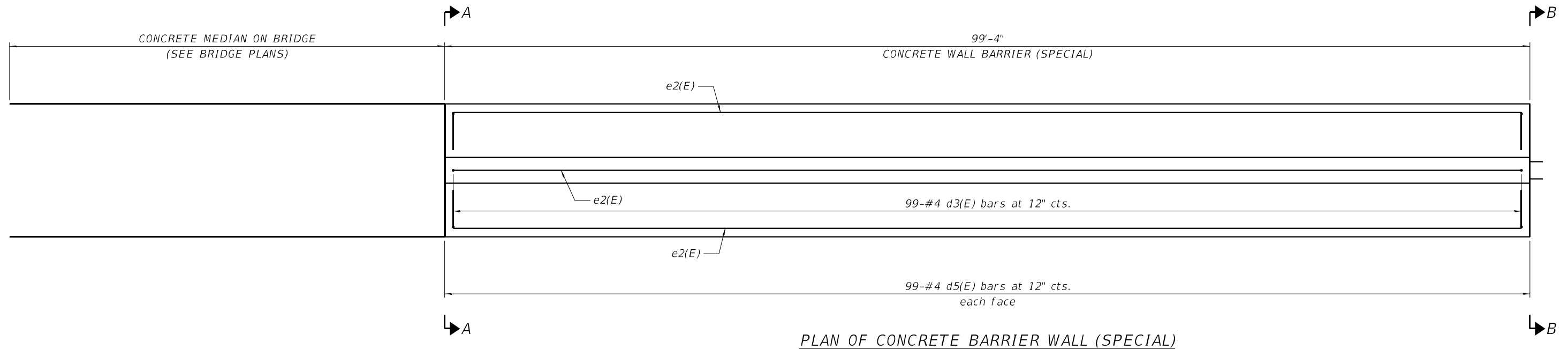

SECTION A-A
STA. 89+71.67

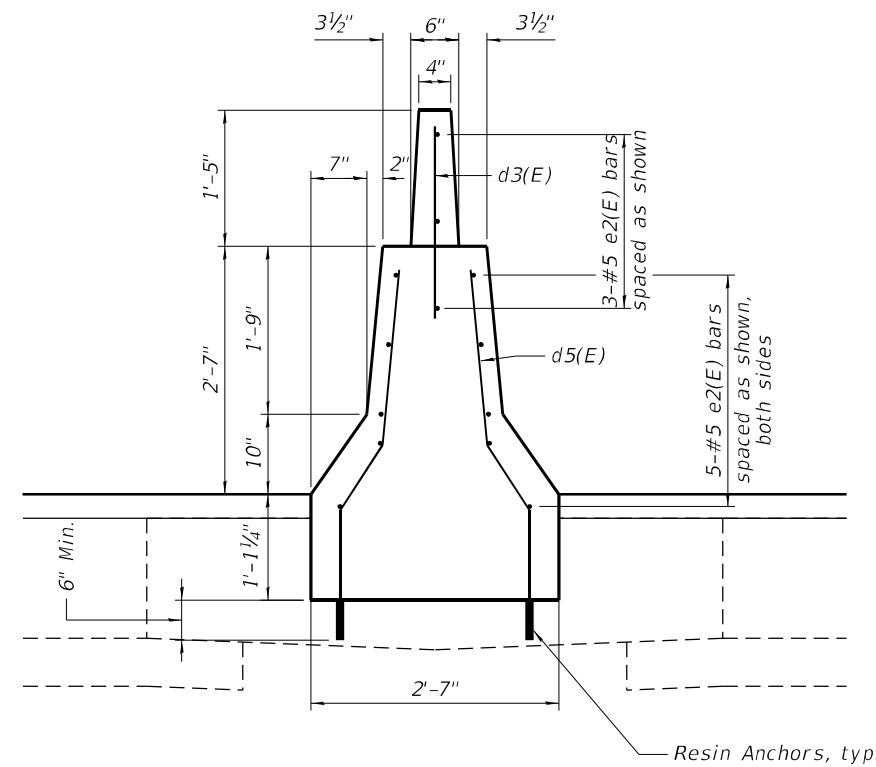

SECTION B-B
STA. 90+70

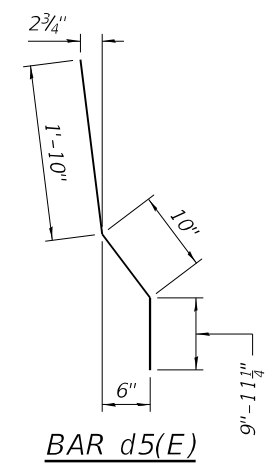

MODEL: D:\efk\2024\813\B60_BR_Bridge\DCN\Design\Final\Revised\825-eh-Detail.dgn
FILE NAME: 2413052.29 B60_BR_Bridge\DCN\Design\Final\Revised\825-eh-Detail.dgn

EFK Moen
Civil Engineering Design

USER NAME = zWaters	DESIGNED - JRD	REVISED -
DRAWN - JRD	REVISED -	
PLOT SCALE = 2,000' / in.	CHECKED - SLD	REVISED -
PLOT DATE = 8/13/2024	DATE - 8/13/2024	REVISED -

STATE OF ILLINOIS
DEPARTMENT OF TRANSPORTATION

DETAIL	
CONCRETE BARRIER WALL (SPECIAL)	
SCALE: N.T.S.	SHEET 1 OF 2 SHEETS STA. TO STA.

F.A.I. RTE.	SECTION	COUNTY	TOTAL SHEETS	SHEET NO.
70	82-5V8-R-2	ST. CLAIR	254	253
CONTRACT NO. 76K02				
ILLINOIS FED. AID PROJECT				

NOTE:
THE IMPROVEMENTS ALONG I-55/70 NOT SHOWN FOR CLARITY

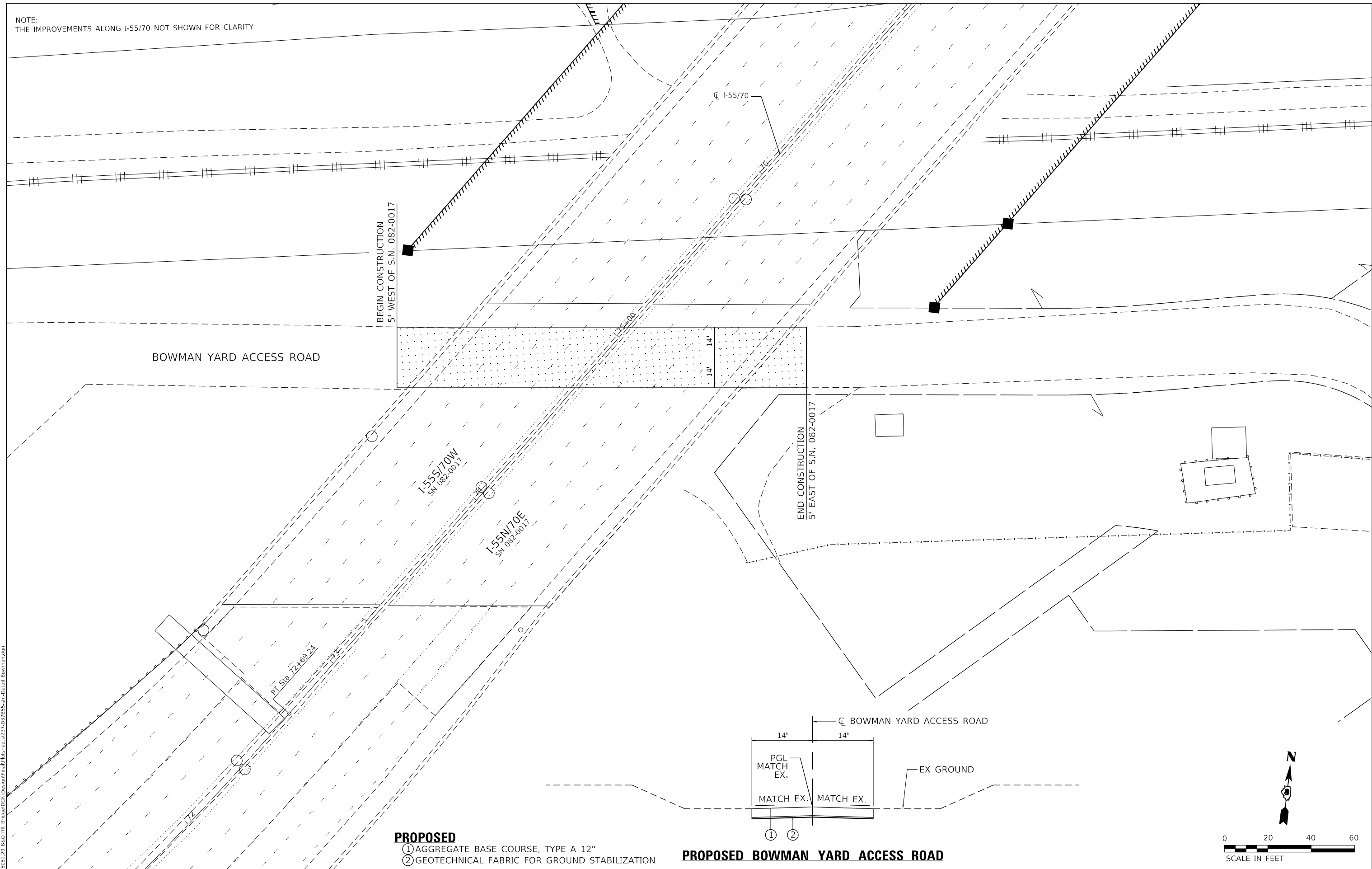

PROPOSED

- ① AGGREGATE BASE COURSE, TYPE A 12"
- ② GEOTECHNICAL FABRIC FOR GROUND STABILIZATION

PROPOSED BOWMAN YARD ACCESS ROAD

**STATE OF ILLINOIS
DEPARTMENT OF TRANSPORTATION**

**DETAIL
BOWMAN YARD ACCESS ROAD**

SCALE: 1"=20' SHEET 2 OF 2 SHEETS STA. TO STA.

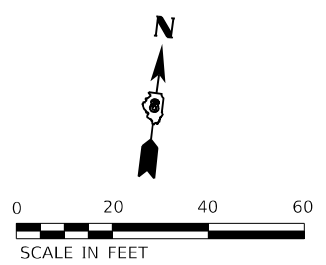

MODEL: D:\efk\2024\813\82-5V8-R-2\BOWMAN.dgn
FILE NAME: 241305239_BGO_BR_813\82-5V8-R-2\BOWMAN.dgn

EFK Moen
Civil Engineering Design

USER NAME = zWaters	DESIGNED - JRD	REVISED -
PLOT SCALE = 40,0000 * / in.	DRAWN - ZJB	REVISED -
PLOT DATE = 8/13/2024	CHECKED - SLD	REVISED -
	DATE - 8/13/2024	REVISED -

F.A.I. RTE.	SECTION	COUNTY	TOTAL SHEETS	SHEET NO.
70	82-5V8-R-2	ST. CLAIR	254	254
CONTRACT NO. 76K02				
ILLINOIS FED. AID PROJECT				