

EXISTING PAVEMENT TYPICAL SECTION

PARKVIEW CIRCLE (E)
STA 76+13

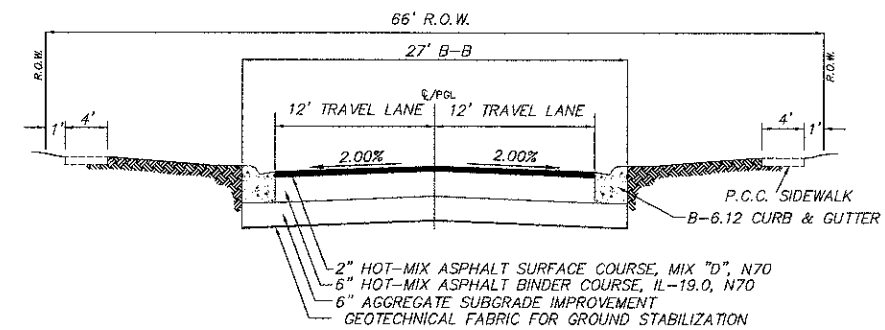

PROPOSED RECONSTRUCTION TYPICAL SECTION

PARKVIEW CIRCLE (E)
STA 76+13

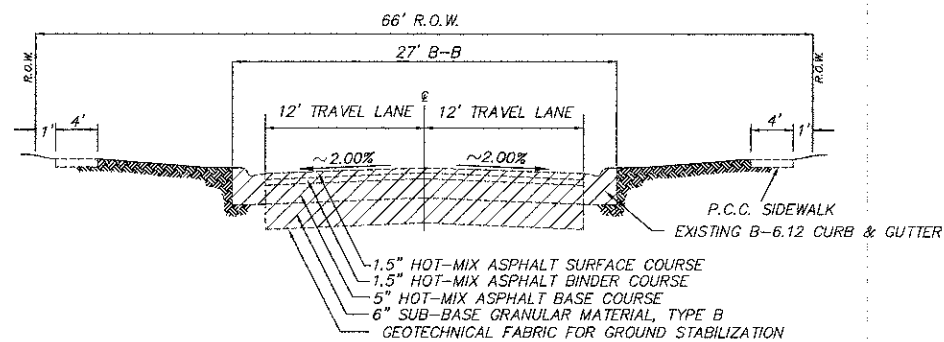

EXISTING PAVEMENT TYPICAL SECTION

ROSEDALE LANE
STA 80+33

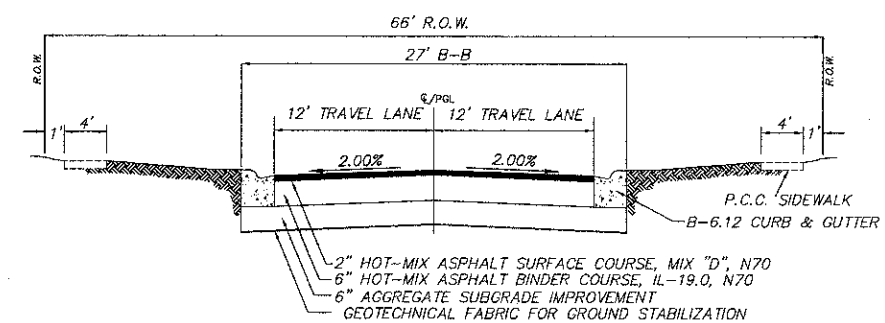

PROPOSED RECONSTRUCTION TYPICAL SECTION

ROSEDALE LANE
STA 80+33

LEGEND

 REMOVAL

PARKVIEW CIRCLE (E), ROSEDALE LANE

HOT-MIX ASPHALT MIXTURE REQUIREMENT	
MIXTURE TYPE	AIR VOIDS @ Ndes
FULL DEPTH PAVEMENT	
HOT-MIX ASPHALT SURFACE COURSE, MIX "D", N70 (IL-9.5 mm); 2"	4% @ 70 GYR
HOT-MIX ASPHALT BINDER COURSE, IL-19.0 N70; 6" (2 LIFT MINIMUM)	4% @ 70 GYR

NOTE: THE UNIT WEIGHT USED TO CALCULATE ALL HOT-MIX ASPHALT SURFACE MIXTURES IS 112 LBS/SQ YD/IN. THE "AC TYPE" FOR POLYMERIZED HMA MIXES SHALL BE "SBS/SBR PG 76-22" AND FOR NON POLYMERIZED HMA SHALL BE "PG 64-22" UNLESS MODIFIED BY DISTRICT ONE SPECIAL PROVISIONS. FOR USE OF RECYCLED MATERIALS SEE DISTRICT ONE SPECIAL PROVISIONS.

FILE NAME =	DESIGNED --	REVISED --
DETAILSH.DWG	DRAWN --	REVISED --
	CHECKED --	REVISED --
	DATE --	REVISED --

STATE OF ILLINOIS
DEPARTMENT OF TRANSPORTATION

Hassell Road STP Project
Typical Section

SCALE: NONE SHEET NO. 7 OF 7 SHEETS STA. TO STA.

F.A.U. RTE.	SECTION	COUNTY	TOTAL SHEETS	SHEET NO.
1100	11-00087-00-FP	Cook	164	14
CONTRACT NO. 63770				
ILLINOIS FED. AID PROJECT CMM 9003(757)				