

SPECIFICATIONS/DATA

24" x 36" PG Style (Stackable) Assembly

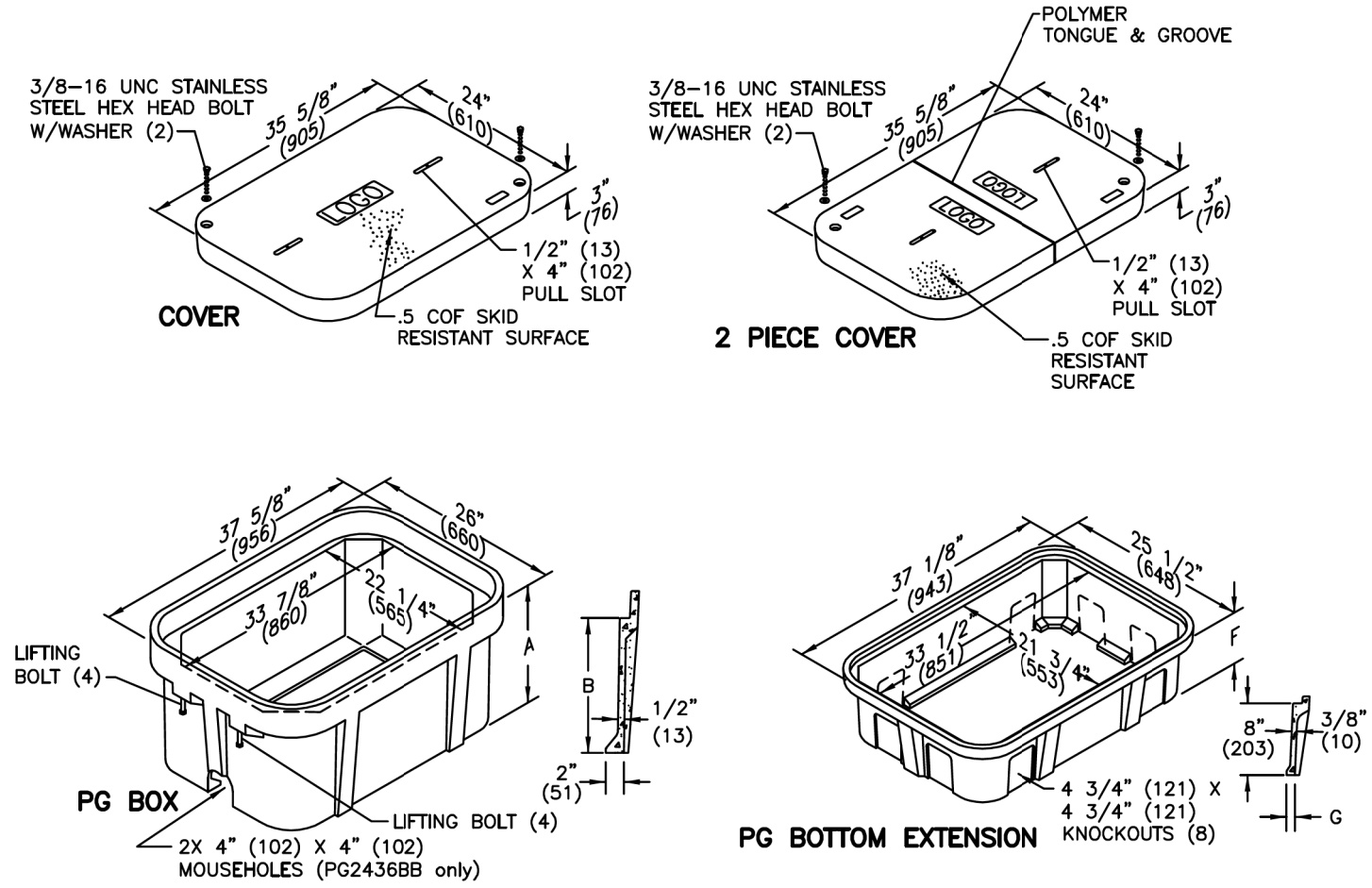

SPECIFICATIONS/DATA

Covers (Blank unless logo is specified)

DESCRIPTION	PART NO.	WEIGHT #	DESIGN/TEST LOAD #	ANSI TIER*
W/2 Bolts	PG2436CA00	100 (45 kg)	8,000 / 12,000	8
Gasketed w/2 Bolts	PG2436CG00	100 (45 kg)	8,000 / 12,000	8
2-Piece w/2 Bolts	PG2436CS00	122 (55 kg)	8,000 / 12,000	8
No Bolts	PG2436WA00	100 (45 kg)	8,000 / 12,000	8
Heavy Duty w/2 Bolts	PG2436HA00	115 (52 kg)	15,000 / 22,500	15
Gasketed Heavy Duty w/2 Bolts	PG2436HG00	115 (52 kg)	15,000 / 22,500	15
Heavy Duty 2-Piece w/2 Bolts	PG2436HS00	122 (55 kg)	15,000 / 22,500	15
Heavy Duty w/2 Bolts	PG2436HH00	122 (55 kg)	22,500 / 33,750	22

SEE NOTE 1
 Gasketed covers and bolt grommets must be used with a gasketed box. Gaskets reduce the inflow of fluids but do not make the enclosure water tight.

PG Boxes (Stackable with self-aligning, replaceable EZ Nut) **24" - 42" Deep boxes must be used as bottom of any stack.)

DESCRIPTION	PART NO.	WEIGHT #	DIMENSION A	DIMENSION B	DESIGN/TEST LOAD #	ANSI TIER*
Open Bottom	PG2436BA18	141 (64 kg)	18" (457 mm)	15" (381 mm)	22,500 / 33,750	22
	PG2436BA24	180 (81.6 kg)	24" (610 mm)	21" (533 mm)	22,500 / 33,750	22
	PG2436BA30	196 (88.9 kg)	30" (762 mm)	27" (686 mm)	22,500 / 33,750	22
	PG2436BA36	254 (115 kg)	36" (914 mm)	33" (838 mm)	22,500 / 33,750	22
Open Bottom w/2 Mouseholes	PG2436BA42	293 (133 kg)	42" (1067 mm)	39" (991 mm)	22,500 / 33,750	22
	PG2436BB18	139 (63.1 kg)	18" (457 mm)	15" (381 mm)	22,500 / 33,750	22
	PG2436BB24	178 (80.7 kg)	24" (610 mm)	21" (533 mm)	22,500 / 33,750	22
	PG2436BB30	194 (88.0 kg)	30" (762 mm)	27" (686 mm)	22,500 / 33,750	22
Solid Bottom	PG2436BB36	252 (114 kg)	36" (914 mm)	33" (838 mm)	22,500 / 33,750	22
	PG2436BB42	293 (133 kg)	42" (1067 mm)	39" (991 mm)	22,500 / 33,750	22
	PG2436DA18	171 (78 kg)	18 1/2" (470 mm)	15" (381 mm)	22,500 / 33,750	22
	PG2436DA24	228 (103.4 kg)	24 1/2" (622 mm)	21" (533 mm)	22,500 / 33,750	22
Solid Bottom	PG2436DA30	238 (107.0 kg)	30 1/2" (775 mm)	27" (686 mm)	22,500 / 33,750	22
	PG2436DA36	282 (128 kg)	36 1/2" (927 mm)	33" (838 mm)	22,500 / 33,750	22
	PG2436DA42	321 (146 kg)	42 1/2" (1080 mm)	39" (991 mm)	22,500 / 33,750	22

SEE NOTE 1

NOTE:
 1. OR APPROVED EQUAL

Extensions (For use under 18" deep box only, one per box.)

DESCRIPTION	PART NO.	WEIGHT #	DIMENSION F	DIMENSION G	DESIGN/TEST LOAD #	ANSI TIER*
Open Bottom	PG2436EA08	81 (37 kg)	8 3/4" (222 mm)	1" (25 mm)	22,500 / 33,750	22
Solid Bottom	PG2436RA08	95 (43.1 kg)	9 1/4" (235 mm)	N/A	22,500 / 33,750	22

Dimensions & weights in parentheses are metric equivalent.
 * Loadings comply with ANSI/SCTE 77

**HANDHOLES
 24"X36" PG STYLE (STACKABLE) ASSEMBLY**

DIRECTORY = L:\ROCKFORD\118004\Draw\CA00_Sheet\2012\LDZ...
 USER NAME = Jason Dove



MODEL NAME = Default	DESIGNED - JWD	REVISED -
FILE NAME = D:\264821-eh-light520.dgn	DRAWN - JWD	REVISED -
PLOT SCALE = 40.0018 / 1 in.	CHECKED - AB	REVISED -
PLOT DATE = 11/20/2012 - 11:28:57 AM	DATE - 11/02/2012	REVISED -

**STATE OF ILLINOIS
 DEPARTMENT OF TRANSPORTATION**

**ROADWAY LIGHTING DETAIL
 HANDHOLE, COMPOSITE CONCRETE, TYPE 1**

SCALE: N/A SHEET 20 OF 32 SHEETS STA. TO STA.

F.A.P. RTE.	SECTION	COUNTY	TOTAL SHEETS	SHEET NO.
742	(32, 33) R-1	WINNEBAGO	705	506
CONTRACT NO. 64821			ILLINOIS FED. AID PROJECT	