

SECTION THRU ABUTMENT

** Included in the cost of Pipe Underdrains for Structures.

All drainage system components shall extend to 2'-0" from the end of each wingwall except an outlet pipe shall extend until intersecting with the side slopes. The pipes shall drain into concrete headwalls. (See Article 601.05 of the Standard Specifications and Highway Standard 601101).

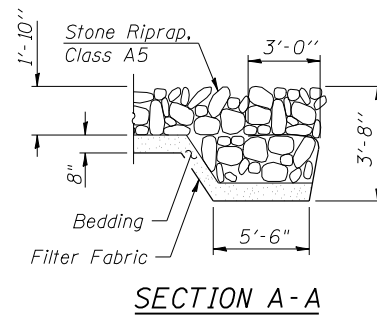

SECTION A-A

GENERAL NOTES

1. The Contractor shall make allowance for the deflection of forms, shrinkage and settlement of falsework, in addition to allowance for dead load deflection. Forms for deck slab shall be removed prior to placement of bridge approach slab.
2. Reinforcement bars designated (E) shall be epoxy coated.
3. Layout of the slope protection system may be varied to suit ground conditions in the field as directed by the Engineer.
4. Slipforming of the parapets is not allowed.

TOTAL BILL OF MATERIAL

ITEM	UNIT	SUPER	SUB	TOTAL
Stone Riprap, Class A5	Sq. Yd.	-	2500	2500
Filter Fabric	Sq. Yd.	-	2500	2500
Removal of Existing Structures	Each	-	-	1
Structure Excavation	Cu. Yd.	-	180	180
Cofferdam Excavation	Cu. Yd.	-	60	60
Cofferdam (Type 1) (Location - 1)	Each	-	1	1
Cofferdam (Type 1) (Location - 2)	Each	-	1	1
Concrete Structures	Cu. Yd.	-	516.6	516.6
Concrete Superstructure	Cu. Yd.	505.8	-	505.8
Bridge Deck Grooving	Sq. Yd.	902	-	902
Concrete Encasement	Cu. Yd.	-	11.0	11.0
Protective Coat	Sq. Yd.	1108	-	1108
Reinforcement Bars, Epoxy Coated	Pound	99920	41150	141070
Bar Splicers	Each	475	339	814
Furnishing Steel Piles HP14x73	Foot	-	5054	5054
Driving Piles	Foot	-	5054	5054
Test Pile Steel HP14x73	Each	-	4	4
Name Plates	Each	1	-	1
Geocomposite Wall Drain	Sq. Yd.	-	52	52
Granular Backfill for Structures	Cu. Yd.	-	74	74
Temporary Sheet Piling	Sq. Ft.	-	211	211
Pipe Underdrains for Structures 4"	Foot	-	144	144
Temporary Soil Retention System	Sq. Ft.	-	780	780

PRINT DRIVER = L:\0-E\B\A\11
 L:\0-E\B\A\11
 SCALE NAME = PLOT
 FILE NAME = 097073-1054-02-01a.dwg



USER NAME = rjt	DESIGNED - ELH/SHL 07/12	REVISED -
ESCA PROJECT NO. 988.11	CHECKED - RDP 10/12	REVISED -
PLOT SCALE = 0.25" = 1' / IN.	DRAWN - HAS 07/12	REVISED -
PLOT DATE = 2/1/2013 10:22:59 AM	CHECKED - ELH 02/13	REVISED -

STATE OF ILLINOIS
 DEPARTMENT OF TRANSPORTATION

GENERAL DATA
 STRUCTURE NO. 097-0078

SHEET NO. 2 OF 23 SHEETS

F.A.P. RTE.	SECTION	COUNTY	TOTAL SHEETS	SHEET NO.
332	4B-1	WHITE	70	23
			CONTRACT NO. 78154	
ILLINOIS FED. AID PROJECT AID				