

SECTION A-A

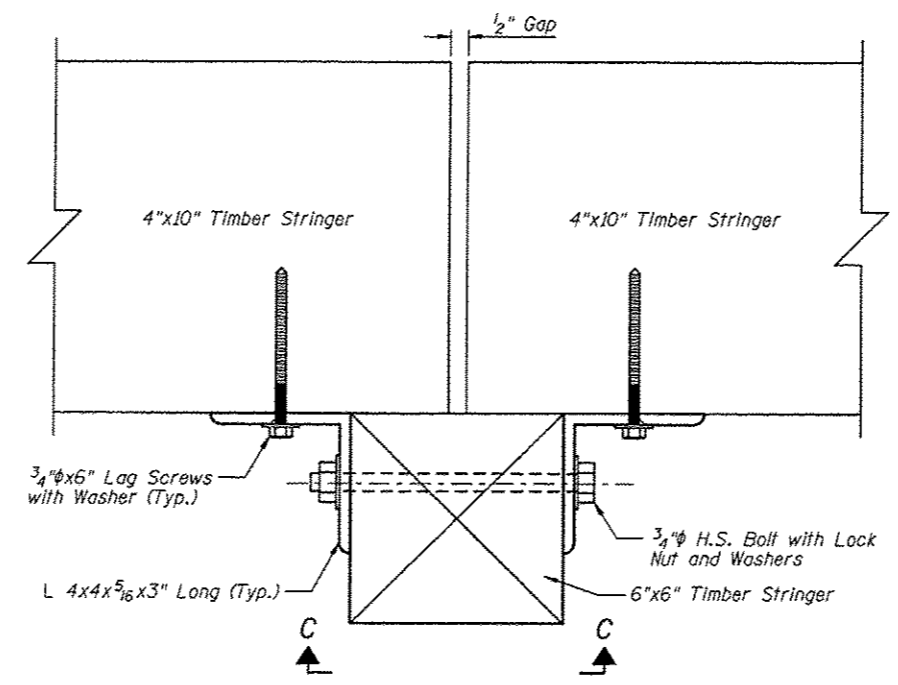

SECTION B-B  
(Section G-G Similar)

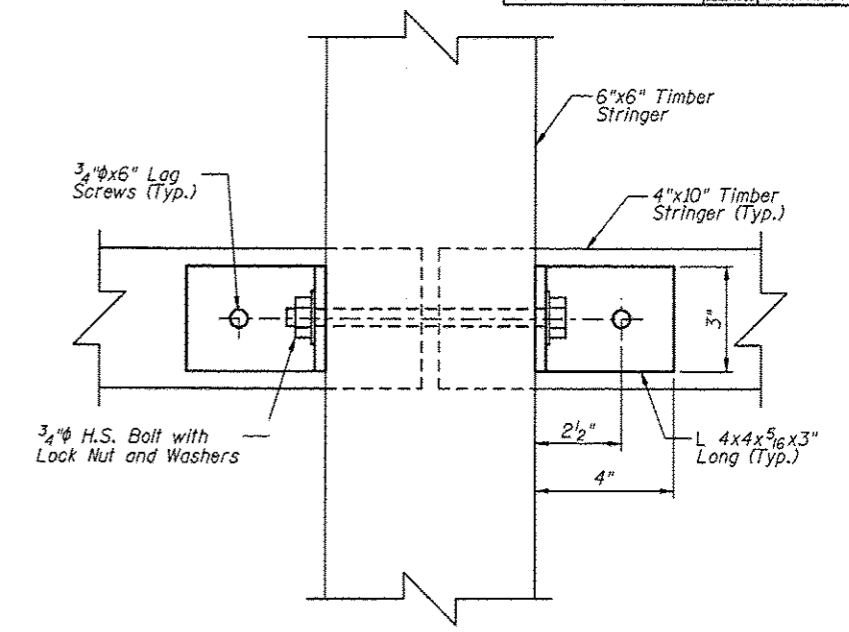

SECTION C-C

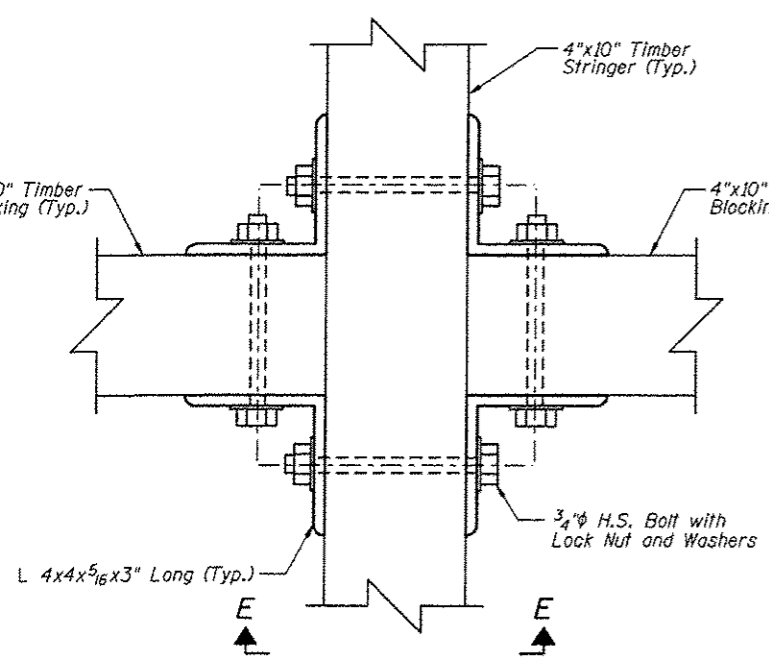

SECTION D-D

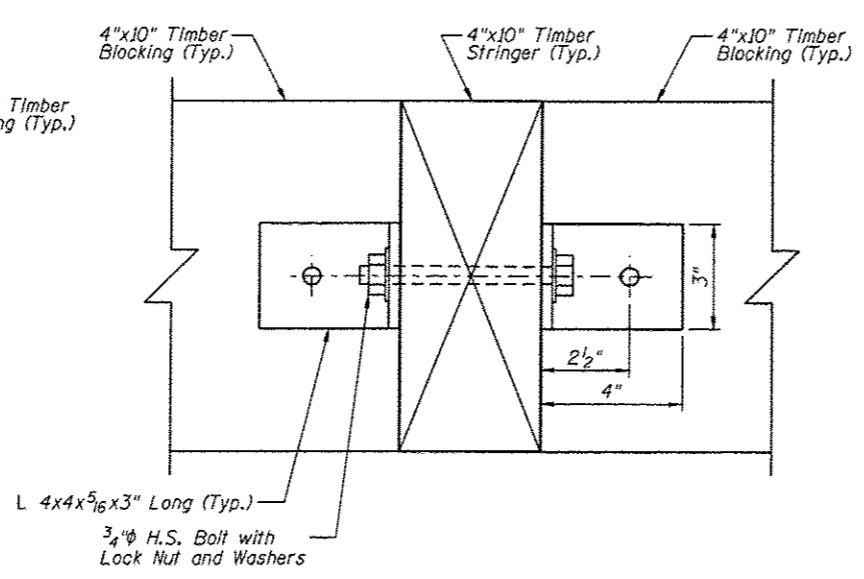

SECTION E-E

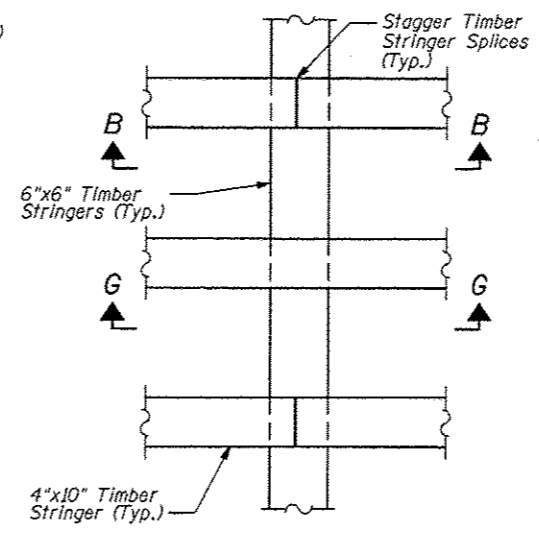

DETAIL A

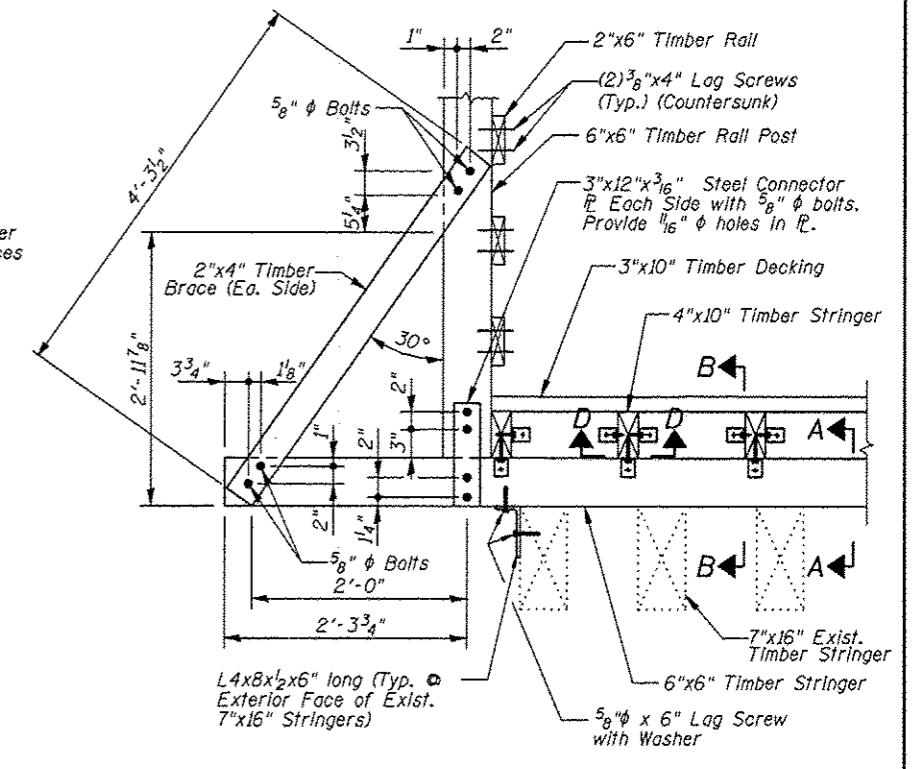

DETAIL B

SUPERSTRUCTURE  
BILL OF MATERIAL

Item	Unit	Quantity
Treated Timber	F.B.M.	8000

Note:

All new timber members shown shall be included in the pay item Treated Timber.

<p>Juneau Associates, Inc. P.C. CONSULTING ENGINEERS AND LAND SURVEYORS 2100 State Street, P.O. Box 1225 Juneau, Alaska 99801 Phone: (907) 586-1100 Fax: (907) 586-1101</p>		<p>GLEN CARBON HERITAGE BIKE TRAIL OVER JUDY BRANCH MADISON COUNTY STATION 186+18.86 STRUCTURE NO. 5</p>									
<p>REVISIONS</p> <table border="1"> <thead> <tr> <th>NO.</th> <th>DATE</th> <th>BY</th> <th>REMARKS</th> </tr> </thead> <tbody> <tr> <td> </td> <td> </td> <td> </td> <td> </td> </tr> </tbody> </table>		NO.	DATE	BY	REMARKS					<p>SCALE: NOT TO SCALE, FOLLOW DIMENSIONS</p>	
NO.	DATE	BY	REMARKS								
<p>DGN. NAME:</p>		<p>DSN. BY: DB</p>	<p>DATE: 10/18/12</p>								
<p>JOB NO. E064403</p>		<p>DWN. BY: EER</p>	<p>DATE: 10/18/12</p>								
<p>DGN. NO.</p>		<p>CHK'D: WWH</p>	<p>DATE: 10/18/12</p>								
<p>OF 810 SHEETS</p>		<p>SHEET 193</p>									

Printed 10:03:14 AM 12/19/2012 M:\STRUCTURE\Drawings\Structure 107-2012\04\03\31 Connection Details.dgn