

INDEX OF SHEETS: 03-08-2019 LETTING ITEM 060

- 1 COVER SHEET
- 2 COMMITMENTS AND JOB SPECIFIC NOTES
- 3 SUMMARY OF QUANTITIES
- 4 LINE DIAGRAM
- 5 SCHEDULE OF QUANTITIES
- 6 CRACK AND JOINT SEALING

HIGHWAY STANDARDS:

- 701400-09
- 701406-12
- 701411-09
- 701901-08

DISTRICT STANDARDS:

- 452001-D4

STATE OF ILLINOIS
DEPARTMENT OF TRANSPORTATION

PROPOSED
HIGHWAY PLANS

FAI ROUTE 155 (INTERSTATE 155)
SECTION (90-14;106;107;108;109;110)CJS
PROJECT NHPP-R40B(038)
PAVEMENT PRESERVATION
TAZEWELL COUNTY

C-94-014-19

FAI ROUTE	SECTION	COUNTY	TOTAL SHEETS	SHEET NO
155	90-14;106;107;108;109;110	TAZEWELL	6	1
				CONTRACT NO. 68E75

D-94-011-19

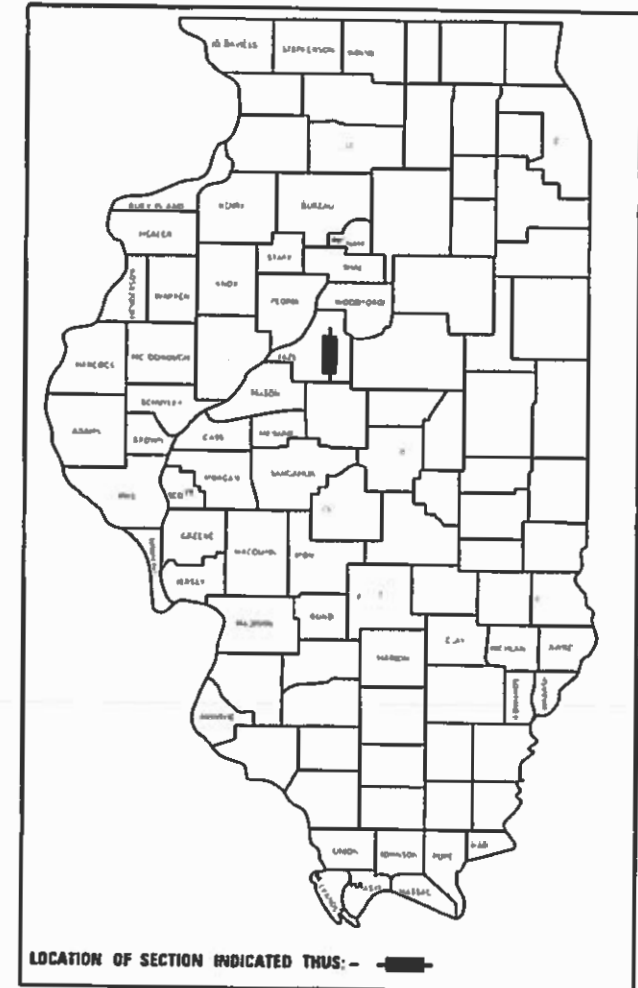

PROJECT DESCRIPTION:

20 MILES OF CRACK AND JOINT SEALING ALONG INTERSTATE 155 FROM INTERSTATE 74 IN MORTON TO THE TAZEWELL/LOGAN COUNTY LINE

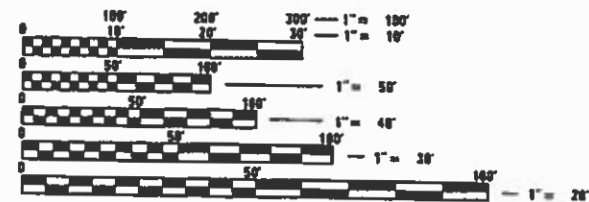

FULL SIZE PLANS HAVE BEEN PREPARED USING STANDARD ENGINEERING SCALES. REDUCED SIZED PLANS WILL NOT CONFORM TO STANDARD SCALES. IN MAKING MEASUREMENTS ON REDUCED PLANS, THE ABOVE SCALES MAY BE USED.

J.U.L.I.E.
JOINT UTILITY LOCATION INFORMATION FOR EXCAVATION
1-800-892-0123
OR 811

PROJECT ENGINEER: RICHARD DOTSON (309) 671-3455
PROJECT MANAGER: RAYMOND SAMARA (309) 671-3460
SQUAD LEADER: MICHAEL JACOBS (309) 671-3460

CATALOG NO. 035674-00D
CONTRACT NO. 68E75

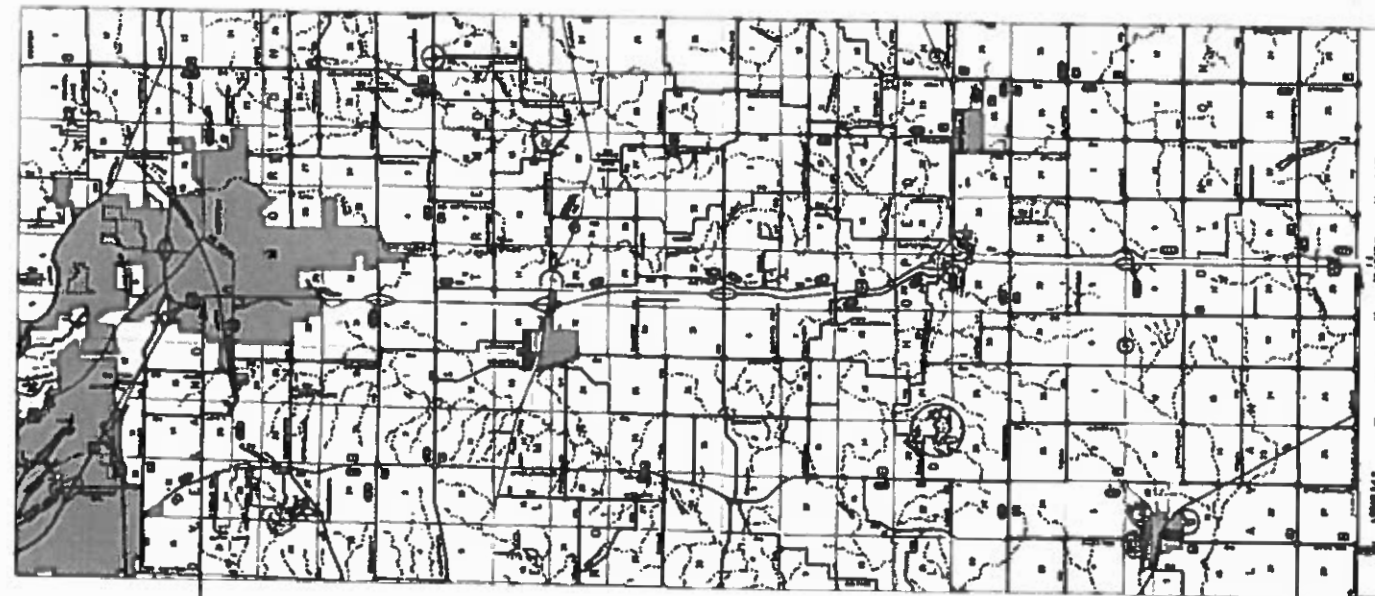

PROJECT BEGINS (I-74):
STA. 35+90

PROJECT ENDS (TAZEWELL/LOGAN COUNTY LINE):
STA. 1102+30 BK.
STA. 546+16 AH.

GROSS LENGTH = 106,729 FT. = 20.214 MILE
NET LENGTH = 105,062 FT. = 19.898 MILE

STATE OF ILLINOIS
DEPARTMENT OF TRANSPORTATION

SUBMITTED December 19, 2018

Randa James
REGIONAL ENGINEER

Feb 1 2019
E.A. ETK
ENGINEER OF DESIGN AND ENVIRONMENT

Feb 1 2019
Paul C. Ch...
DIRECTOR OF HIGHWAYS PROJECT IMPLEMENTATION

PRINTED BY THE AUTHORITY
OF THE STATE OF ILLINOIS

COMMITMENTS

Commitments are not to be altered without the written approval of all parties to which the commitment was made.

NO COMMITMENTS HAVE BEEN MADE FOR THIS PROJECT.

JOB SPECIFIC NOTES

Care shall be exercised to keep sealant off existing pavement markings, any damage to the pavement markings shall be repaired by the contractor at his/her expense. Work shall be done in accordance to section 780 of the standard specifications and to the satisfaction of the engineer.

All dirt and debris created by the routing operation shall be cleaned from the pavement and paved shoulders at the end of the day's operations according to article 107.15 of the standard specifications.

MODEL: \$MODELNAME\$
FILE: \$NAME\$. \$FILE\$

USER NAME = \$USERS\$	DESIGNED -	REVISED -
	DRAWN -	REVISED -
PLOT SCALE = \$SCALE\$	CHECKED -	REVISED -
PLOT DATE = \$DATE\$	DATE -	REVISED -

**STATE OF ILLINOIS
DEPARTMENT OF TRANSPORTATION**

COMMITMENTS AND JOB SPECIFIC NOTES

SCALE: SHEET 1 OF 1 SHEETS STA. TO STA.

F.A.J. RTE.	SECTION	COUNTY	TOTAL SHEETS	SHEET NO.
155	(90-14;106;107;108;109;110)CJS	TAZEWELL	6	2
CONTRACT NO. 68E75			ILLINOIS FED. AID PROJECT	

CODE NO.	ITEM	UNIT	TOTAL QUANTITY	CONST. CODE
				90% FEDERAL
				10% STATE
				TAZEWELL
				COUNTY
				0005
67100100	MOBILIZATION	L SUM	1	1
70100420	TRAFFIC CONTROL AND PROTECTION, STANDARD 701411	EACH	28	28
70100700	TRAFFIC CONTROL AND PROTECTION, STANDARD 701406	L SUM	1	1
X4510100	CRACK ROUTING AND FILLING	POUND	145000	145000

MODEL: #MODEL NAME \$
FILE NAME: \$FILE \$

USER NAME = \$USER\$	DESIGNED -	REVISED -
PLOT SCALE = \$SCALE\$	DRAWN -	REVISED -
PLOT DATE = \$DATE\$	CHECKED -	REVISED -
	DATE -	REVISED -

**STATE OF ILLINOIS
DEPARTMENT OF TRANSPORTATION**

SUMMARY OF QUANTITIES

F.A.I RTE.	SECTION	COUNTY	TOTAL SHEETS	SHEET NO.
155	190-14:106:107:108:109:110:J5	TAZEWELL	6	3
CONTRACT NO. 68E75				
ILLINOIS FED. AID PROJECT				

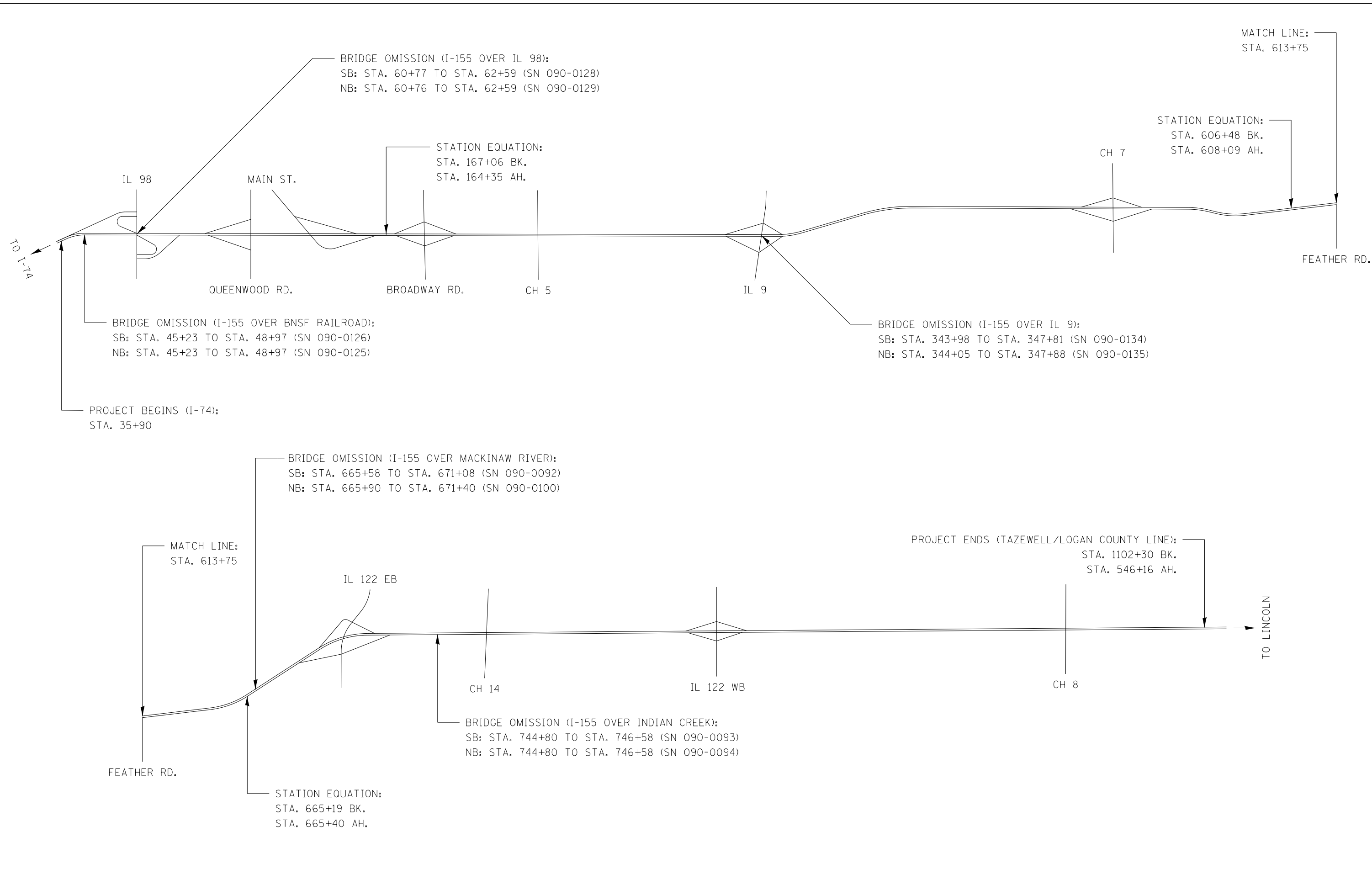

MODEL: \\MODELS\FILES
FILE NAME: ST153

USER NAME = \$USERS	DESIGNED -	REVISED -
	DRAWN -	REVISED -
PLOT SCALE = \$SCALE\$	CHECKED -	REVISED -
PLOT DATE = \$DATE\$	DATE -	REVISED -

**STATE OF ILLINOIS
DEPARTMENT OF TRANSPORTATION**

LINE DIAGRAM			
SCALE:	SHEET 1	OF 1	SHEETS
	STA.		TO STA.

F.A.J. RTE.	SECTION	COUNTY	TOTAL SHEETS	SHEET NO.
155	(90-14;106;107;108;109;110)CJ5	TAZEWELL	6	4
CONTRACT NO. 68E75				
ILLINOIS FED. AID PROJECT				

CRACK ROUTING AND FILLING	
LOCATION	POUND
I-155	145,000
TOTAL	145,000

MOBILIZATION	
LOCATION	L SUM
I-155	1
TOTAL	1

TRAFFIC CONTROL AND PROTECTION, STANDARD 701406	
LOCATION	L SUM
I-155	1
TOTAL	1

TRAFFIC CONTROL AND PROTECTION, STANDARD 701411	
LOCATION	EACH
I-155	28
TOTAL	28

MODEL: \$MODELNAME\$
FILE NAME: \$FILE\$

USER NAME = \$USERS	DESIGNED -	REVISED -
	DRAWN -	REVISED -
PLOT SCALE = \$SCALE\$	CHECKED -	REVISED -
PLOT DATE = \$DATES	DATE -	REVISED -

**STATE OF ILLINOIS
DEPARTMENT OF TRANSPORTATION**

SCHEDULE OF QUANTITIES

SCALE: SHEET 1 OF 1 SHEETS STA. TO STA.

F.A.J. RTE.	SECTION	COUNTY	TOTAL SHEETS	SHEET NO.
155	(90-14;106;107;108;109;110)CJS	TAZEWELL	6	5
CONTRACT NO. 68E75				
		ILLINOIS	FED. AID PROJECT	

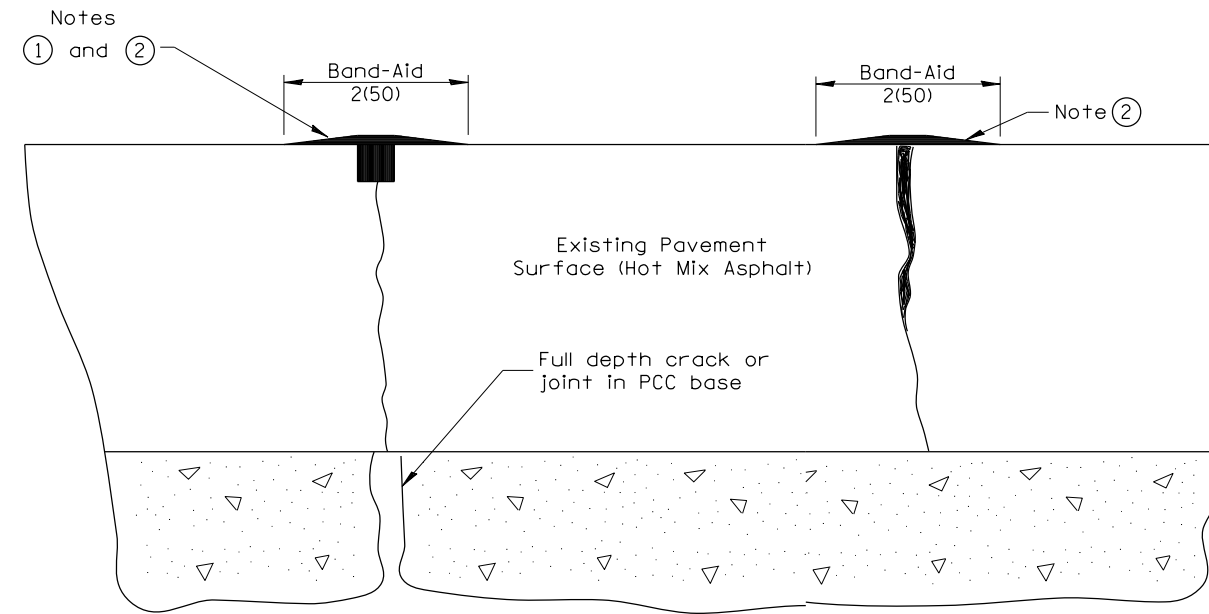

**PRIMARY TRANSVERSE,
LONGITUDINAL CRACK &
P.C.C. CENTERLINE JOINT**

**SECONDARY
ADJACENT CRACK**

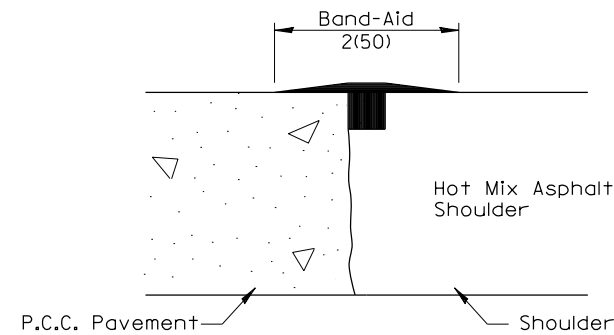

**SHOULDER JOINT (Notes 1 & 2) AND
LONGITUDINAL RANDOM CRACK (Notes 1 & 3)**

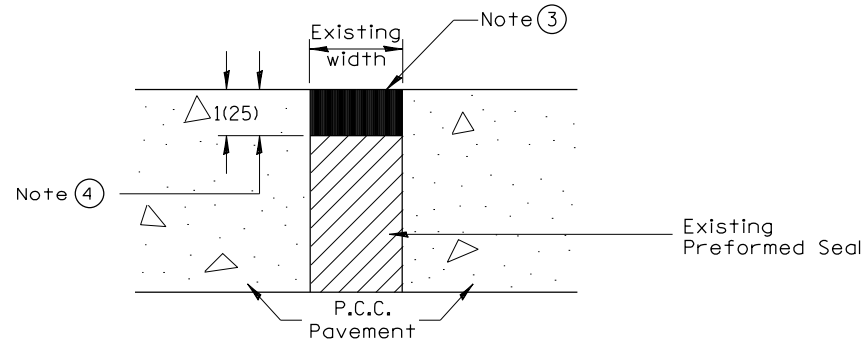

TRANSVERSE EXPANSION JOINT

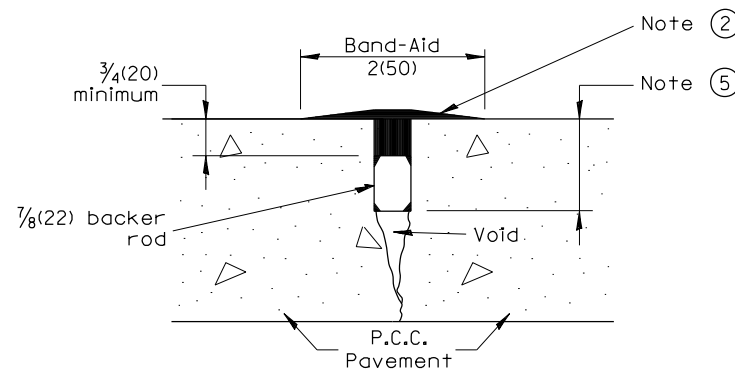

SPECIAL TREATMENT - BACKER ROD
FOR JOINTS AND/OR CRACKS GREATER
THAN 3/4(20) DEEP
(DOES NOT APPLY TO TRANSVERSE RANDOM CRACKS
IN CONTINUOUSLY REINFORCED PAVEMENTS)

NOTES

- ① Route or saw to 3/4(20) wide by 3/4(20) deep; (1:1 ratio).
- ② Overfill with sealant; squeegee to provide 2 (50) wide flush "band-aid" effect; feather edges flush.
- ③ Seal flush without "band-aid" effect.
- ④ Route to 1(25) depth; clean and reface walls.
- ⑤ Route or saw 3/4(20) wide by variable depth. Depth based upon crack or joint depth and 3/4(20) minimum sealer over backer rod.
- ⑥ Crack and Joint Sealing shall conform to Section 451 and 452
- ⑦ The "Band Aid" width shall be reduced or eliminated in areas adjacent to existing pavement markings as directed by the Engineer.

All dimensions are in inches (millimeters) unless otherwise noted.

01-01-97	RENUM. C-36.01, NEW REVISE BOX	T.P.
05-01-97	REVISED	E.T.
10-16-06	REVISED TO 2007 SPEC.	M.A.
01-01-17	REVISED	R.D.

**STATE OF ILLINOIS
DEPARTMENT OF TRANSPORTATION**

CRACK AND JOINT SEALING

NOT TO SCALE

CADD STD. 452001-D4

F.A.I. RTE.	SECTION	COUNTY	TOTAL SHEETS	SHEET NO.
155	(90-14;106;107;108;109;110)CJS	TAZEWELL	6	6
			CONTRACT NO. 68E75	
ILLINOIS FED. AID PROJECT				