

FAP RTE.	SECTION	COUNTY	TOTAL SHEETS	SHEET NO.
372	3091-RS-4	COOK	27	1

C62728  
D-91-156-04

STATE OF ILLINOIS  
DEPARTMENT OF TRANSPORTATION  
DIVISION OF HIGHWAYS

# PLANS FOR PROPOSED HIGHWAY

FOR INDEX OF SHEETS, SEE SHEET NO. 2

1 FAP ROUTE 372: IL 171 (FIRST AVE.)  
I-290 TO LAKE ST.  
2 FAU ROUTE 1419: MADISON STREET  
FIRST AVE. TO DES PLAINES RIVER  
SECTION: 3091 RS-4  
RESURFACING (MAINTENANCE)  
COOK COUNTY  
C-91-156-04

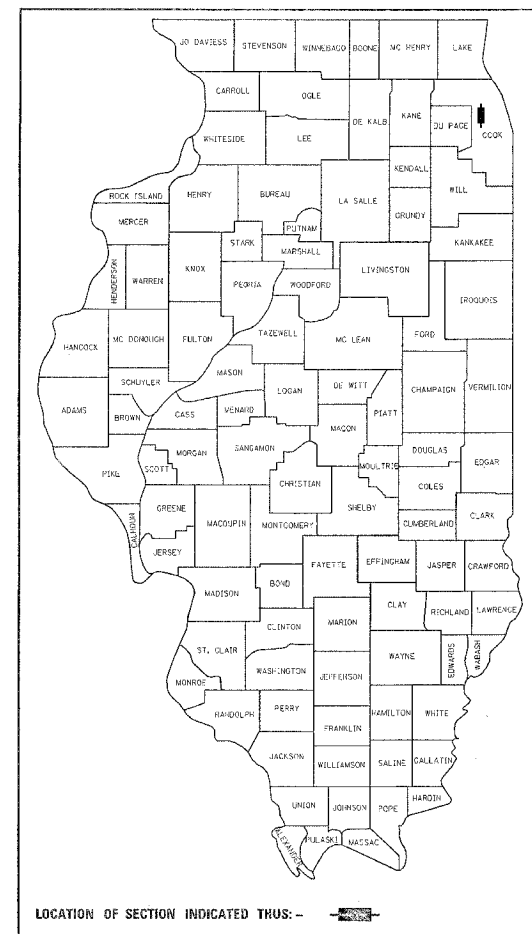

IMPROVEMENT LOCATED IN  
THE VILLAGE OF MAYWOOD

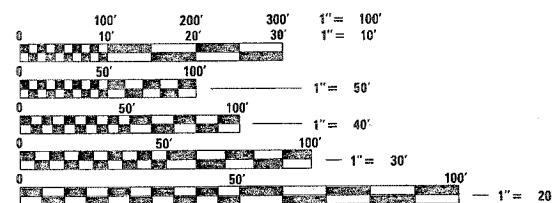

FULL SIZE PLANS HAVE BEEN PREPARED USING STANDARD ENGINEERING SCALES, REDUCED SIZED PLANS WILL NOT CONFORM TO STANDARD SCALES, IN MAKING MEASUREMENTS ON REDUCED PLANS, THE ABOVE SCALES MAY BE USED.

J.U.L.I.E.  
JOINT UTILITY LOCATION INFORMATION FOR EXCAVATION  
1-800-892-0123

CONTRACT NO. 62728

IMPROVEMENT BEGINS  
LOCATION 2  
STA. 3 + 70

IMPROVEMENT BEGINS  
LOCATION 1  
STA. 26 + 24

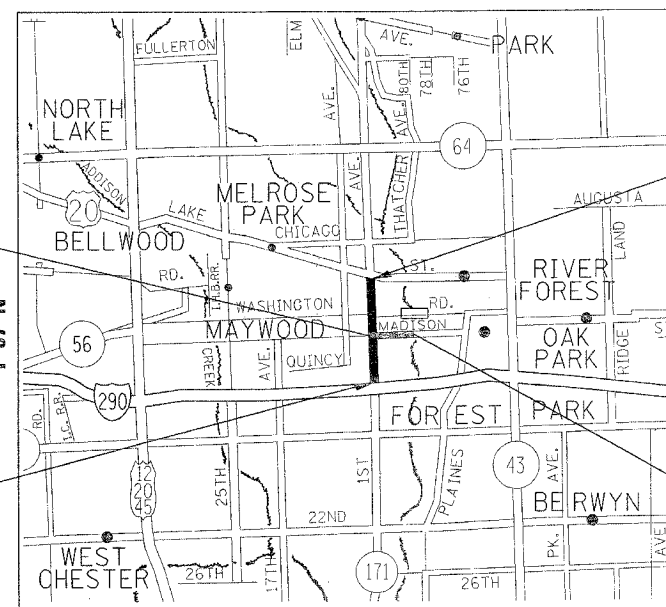

IMPROVEMENT ENDS  
LOCATION 1  
STA. 85 + 00

TRAFFIC DATA:  
① 2005 ADT = 27,000  
② 2002 ADT = 14,300  
POSTED SPEED LIMIT = 35 MPH

IMPROVEMENT ENDS  
LOCATION 2  
STA. 14 + 40

1 GROSS & NET LENGTH OF IMPROVEMENT = 5876 FT. = 1.113 MILES  
2 GROSS & NET LENGTH OF IMPROVEMENT = 1070 FT. = 0.202 MILES

STATE OF ILLINOIS  
DEPARTMENT OF TRANSPORTATION  
DIVISION OF HIGHWAYS

SUBMITTED Dec 21 2006

Diane O'Keefe / CA  
DEPUTY DIRECTOR OF HIGHWAYS, REGION ENGINEER

February 2, 2007  
Eric E. Harms / E  
ENGINEER OF DESIGN AND ENVIRONMENT

February 2, 2007  
Milton R. See, P.E. / D  
DIRECTOR OF HIGHWAYS, CHIEF ENGINEER

PRINTED BY AUTHORITY OF THE  
STATE OF ILLINOIS

DIST. 1 DESIGN - PLAN PREP ENGINEER / KEN ENG / BOB BORO (847) 705-4240

F.A.P. RTE.	SECTION	COUNTY	TOTAL SHEETS	SHEET NO.
372	3091-RS-4	COOK	27	2
STA. 26+24		TO STA. 85+00		
FED. ROAD DIST. NO.		ILLINOIS	FED. AID PROJECT	

C62728

INDEX OF SHEETS

STANDARDS

GENERAL NOTES

SHEET NO.	DESCRIPTION
1	TITLE SHEET
2	INDEX OF SHEETS, STATE STANDARDS, AND GENERAL NOTES
3-4	SUMMARY OF QUANTITIES
5-6	TYPICAL SECTIONS
7-9	ROADWAY & PAVEMENT MARKING PLANS
10-15	DETECTOR LOOP PLANS
16	DRIVEWAY DETAILS DISTANCE BETWEEN ROW AND FACE OF CURB < 15' (4.5 m)
17	DETAILS FOR FRAMES AND LIDS ADJUSTMENT WITH MILLING
18	PAVEMENT PATCHING FOR HMA SURFACE PAVEMENT
19	CURB OR CURB AND GUTTER REMOVAL AND REPLACEMENT
20	BUTT JOINTS AND HMA TAPER DETAILS
21	TRAFFIC CONTROL AND PROTECTION FOR SIDE ROADS, INTERSECTIONS, AND DRIVEWAYS
22	TYPICAL APPLICATIONS RAISED REFLECTIVE PAVEMENT MARKERS (SNOW-PLOW RESISTANT)
23	DISTRICT ONE TYPICAL PAVEMENT MARKINGS
24	TRAFFIC CONTROL AND PROTECTION AT TURN BAYS (TO REMAIN OPEN TO TRAFFIC)
25	PAVEMENT MARKING LETTERS AND SYMBOLS FOR TRAFFIC STAGING
26	TEMPORARY INFORMATION SIGNING
27	DETECTOR LOOP INSTALLATION DETAIL FOR ROADWAY RESURFACING

STANDARD NO.	DESCRIPTION
000001-04	STANDARD SYMBOLS, ABBREVIATIONS AND PATTERNS
420001-06	CLASS C AND D PATCHES
604001-02	FRAME AND LIDS, TYPE I
604086-01	FRAME AND GRATE, TYPE 23
701301-02	LANE CLOSURE, 2L, 2W, SHORT TIME OPERATIONS
701426-02	LANE CLOSURE, MULTILANE INTERMITTENT OR MOVING OPERATIONS FOR SPEEDS ≥ 45 MPH
701606-04	URBAN LANE CLOSURE, MULTILANE 2W WITH MOUNTABLE MEDIAN
701701-04	URBAN LANE CLOSURE, MULTILANE INTERSECTION
702001-06	TRAFFIC CONTROL DEVICES
780001-01	TYPICAL PAVEMENT MARKINGS

- BEFORE STARTING ANY EXCAVATION, THE CONTRACTOR SHALL CALL "JULIE" AT 1-800-892-0123. FOR FIELD LOCATIONS OF BURIED ELECTRIC, TELEPHONE AND GAS FACILITIES. (48 HOURS NOTIFICATION IS REQUIRED)
- THE CONTRACTOR SHALL COORDINATE CONSTRUCTION ACTIVITIES WITH UTILITY COMPANIES AND THE CITY OF MAYWOOD
- THE CONTRACTOR WILL NOT BE ALLOWED TO SET UP A YARD OR FIELD OFFICE ON STATE PROPERTY WITHOUT WRITTEN PERMISSION FROM THE DEPARTMENT.
- BUTT JOINTS WILL BE INSTALLED AT THE ENDS OF ALL RESURFACING (WHERE RESURFACING MEETS EXISTING PAVEMENT), IN ACCORDANCE WITH THE "BUTT JOINT AND HMA TAPER DETAILS".
- NO PERMANENT LANE CLOSURES WILL BE ALLOWED. MILLING, RESURFACING, STRUCTURE ADJUSTMENTS AND PATCHING OPERATIONS WILL BE DONE WITH DAY TIME LANE CLOSURES ONLY.
- 10 FT (3 METER) TRANSITIONS SHALL BE USED TO MATCH PROPOSED CURB AND GUTTER AND MEDIAN ITEMS OF WORK TO EXISTING CURB & GUTTER AND MEDIANS IN THE FIELD, UNLESS OTHERWISE SHOWN. THE TRANSITION SHALL BE PAID FOR AT THE CONTRACT UNIT PRICE FOR THE PROPOSED ITEMS OF WORK SPECIFIED.
- THE RESIDENT ENGINEER SHALL CONTACT WALTER CZARNY, AREA TRAFFIC FIELD ENGINEER AT (773)685-8386 A MINIMUM OF TWO WEEKS PRIOR TO PLACEMENT OF PERMANENT PAVEMENT MARKINGS.
- WHEN MILLED PAVEMENT IS OPEN TO TRAFFIC THE MAXIMUM GRADE DIFFERENTIAL BETWEEN PASSES OF THE MILLING MACHINE SHALL NOT EXCEED 1/4" (40 MM) WHERE THE SPEED LIMIT IS 45 MPH (80 KM/H) OR LESS AND 1" (25 MM) WHERE THE SPEED LIMIT IS GREATER THAN 45 MPH (80 KM/H). WITH WRITTEN APPROVAL FROM THE ENGINEER, A MAXIMUM GRADE DIFFERENTIAL OF 3" (75 MM) MAY BE ALLOWED IN THE EDGE OF THE MILLING IF THE SLOPE IS A MINIMUM 1:3 (V:H).
- DESIGNERS BASED QUANTITIES ON PATCHING FIRST THEN MILLING
- DRIVEWAY AND SIDEWALK QUANTITIES HAVE BEEN INCLUDED FOR THE RESTORATION BEHIND THE CURB & GUTTER REMOVAL AND REPLACEMENT

REVISIONS	
NAME	DATE

ILLINOIS DEPARTMENT OF TRANSPORTATION

INDEX OF SHEETS, GENERAL NOTES AND STATE STANDARDS

SCALE: VERT. NONE  
HORIZ. DATE APRIL 9, 2004

DRAWN BY S.E.S.  
CHECKED BY

C62728

FILE NO.	SECTION	COUNTY	TOTAL SHEETS	SHEET NO.
372	3091-RS-4	COOK	27	3
FED. ROAD DIST. NO. 1		ILLINOIS	HIGHWAY PROJECT	

SUMMARY OF QUANTITIES			TOTAL QUANTITIES	CONSTRUCTION TYPE CODE				
CODE NO	ITEM	UNIT		URBAN 1000 100% STATE FIRST AVE.	URBAN 1000 100% STATE MADISON STREET			
35501316	HOT-MIX ASPHALT BASE COURSE, 8"	SQ YD	12.5	12.5				
40600200	BITUMINOUS MATERIALS (PRIME COAT)	TON	34.75	30	4.75			
40600300	AGGREGATE (PRIME COAT)	TON	173	150	23			
40600400	MIXTURE FOR CRACKS, JOINTS, AND FLANGEWAYS	TON	5	4	1.0			
40600895	CONSTRUCTING TEST STRIP	EACH	3	2	1			
40600982	HOT-MIX ASPHALT SURFACE REMOVAL - BUTT JOINT	SQ YD	549	501	48			
40601005	HOT-MIX ASPHALT REPLACEMENT OVER PATCHES	TON	596	441	155			
40603310	HOT-MIX ASPHALT SURFACE COURSE, MIX "C", N50	TON	1.5	1.5				
40603340	HOT-MIX ASPHALT SURFACE COURSE, MIX "D", N70	TON	590		590			
40603595	POLYMERIZED HOT-MIX ASPHALT SURFACE COURSE, MIX "F", N90	TON	3750	3750				
42001300	PROTECTIVE COAT	SQ YD	525	525				
42300400	PORTLAND CEMENT CONCRETE DRIVEWAY PAVEMENT, 8 INCH	SQ YD	74	74				
42400200	PORTLAND CEMENT CONCRETE SIDEWALK 5 INCH	SQ FT	1820	1820				
44000158	HOT-MIX ASPHALT SURFACE REMOVAL, 2 1/4"	SQ YD	6900		6900			
44000159	HOT-MIX ASPHALT SURFACE REMOVAL, 2 1/2"	SQ YD	37208	37208				
44000600	SIDEWALK REMOVAL	SQ FT	1820	1820				
44001700	COMBINATION CONCRETE CURB AND GUTTER REMOVAL AND REPLACEMENT	FOOT	1170	1130	40			
44002216	HOT-MIX ASPHALT REMOVAL OVER PATCHES, 4"	SQ YD	685		685			
44002224	HOT-MIX ASPHALT REMOVAL OVER PATCHES, 6"	SQ YD	1250	1250				
44004250	PAVED SHOULDER REMOVAL	SQ YD	13	13				
44201753	CLASS D PATCHES, TYPE II, 9 INCH	SQ YD	450	410	40			
44201757	CLASS D PATCHES, TYPE III, 9 INCH	SQ YD	344	242	102			
44201759	CLASS D PATCHES, TYPE IV, 9 INCH	SQ YD	730	370	360			
60250200	CATCH BASINS TO BE ADJUSTED	EACH	44	44				

SUMMARY OF QUANTITIES			TOTAL QUANTITIES	CONSTRUCTION TYPE CODE				
CODE NO	ITEM	UNIT		URBAN 1000 100% STATE FIRST AVE.	URBAN 1000 100% STATE MADISON STREET			
60300105	FRAMES AND GRATES TO BE ADJUSTED	EACH	10	10				
60300305	FRAMES AND LIDS TO BE ADJUSTED	EACH	16	14	2			
60300310	FRAMES AND LIDS TO BE ADJUSTED (SPECIAL)	EACH	139	130	9			
60401030	FRAMES, TYPE 23	EACH	12	12				
60404950	FRAMES AND GRATES, TYPE 24	EACH	20	20				
60406000	FRAMES AND LIDS, TYPE 1, OPEN LID	EACH	18	18				
60406100	FRAMES AND LIDS, TYPE 1, CLOSED LID	EACH	79	66	13			
67000400	ENGINEER'S FIELD OFFICE, TYPE A	CAL MO	4	2	2			
67100100	MOBILIZATION	L SUM	1	.5	.5			
70102625	TRAFFIC CONTROL AND PROTECTION, STANDARD 701606	L SUM	1	1				
70102635	TRAFFIC CONTROL AND PROTECTION, STANDARD 701701	L SUM	1	1				
70103815	TRAFFIC CONTROL SURVEILLANCE	CAL DA	8	6	2			
70300100	SHORT-TERM PAVEMENT MARKING	FOOT	2560	2370	190			
70300210	TEMPORARY PAVEMENT MARKING - LETTERS AND SYMBOLS	SQ FT	1202	1202				
70300220	TEMPORARY PAVEMENT MARKING - LINE 4"	FOOT	35618	33268	2350			
70300240	TEMPORARY PAVEMENT MARKING - LINE 6"	FOOT	6176	6176				
70300260	TEMPORARY PAVEMENT MARKING - LINE 12"	FOOT	2802	2802				
70300280	TEMPORARY PAVEMENT MARKING - LINE 24"	FOOT	1246	1246				
70300510	PAVEMENT MARKING TAPE, TYPE III - LETTERS AND SYMBOLS	SQ FT	601	601				
70300520	PAVEMENT MARKING TAPE, TYPE III 4"	FOOT	21746	21746				
* 78000100	THERMOPLASTIC PAVEMENT MARKING - LETTERS AND SYMBOLS	SQ FT	601	601				
* 78000200	THERMOPLASTIC PAVEMENT MARKING - LINE 4"	FOOT	35618	33268	2350			

\*SPECIALTY ITEMS

REVISIONS	
NAME	DATE

ILLINOIS DEPARTMENT OF TRANSPORTATION  
SUMMARY OF QUANTITIES

PLOT DATE: 12/22/2006

12/22/2006 10:45:43 AM C:\PROJECTS\3091-RS-4\3091-RS-4-3.DWG



F. A. NO.	SECTION	COUNTY	TOTAL SHEETS	SHEET NO.
372	3091-RS-4	COOK	27	5
STA.	26+20	TO STA.	85+00	
FED. ROAD DIST. NO.	ILLINOIS	FED. AID PROJECT		

C62728

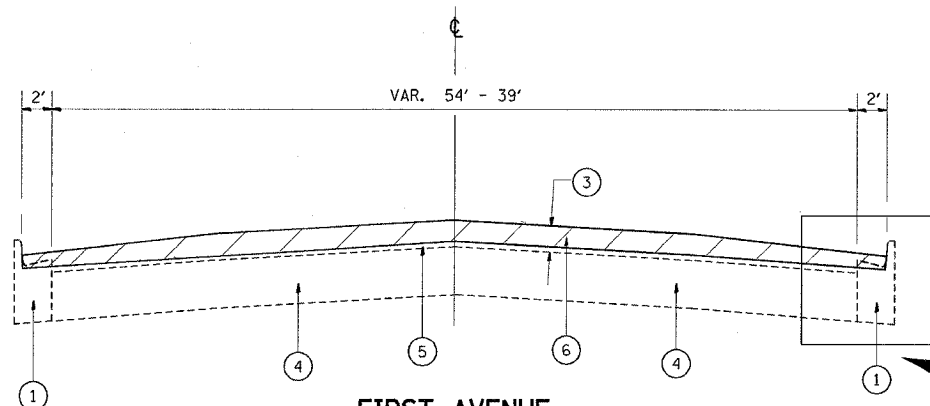

**FIRST AVENUE**  
EXISTING TYPICAL CROSS SECTION  
( FROM STATIONS 26+22 TO 61+06 )

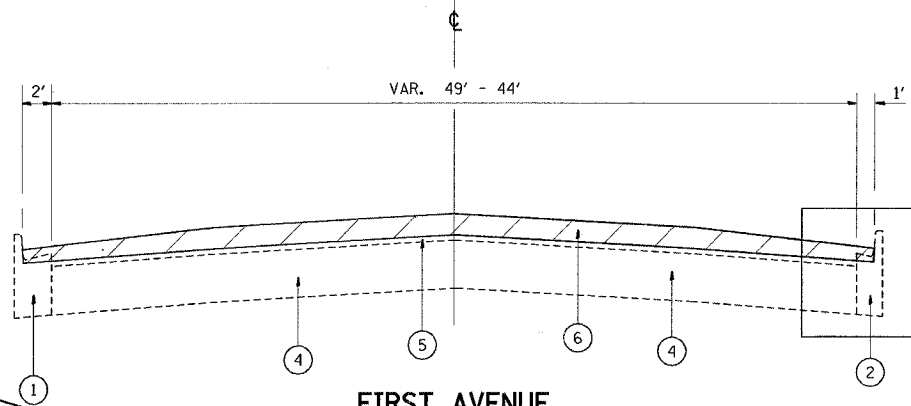

**FIRST AVENUE**  
EXISTING TYPICAL CROSS SECTION  
( FROM STATIONS 61+06 TO 85+00 )

**LEGEND :**

- ① EXISTING COMB. CONC. CURB & GUTTER, TYPE B-6.24
- ② EXISTING COMB. CONC. CURB & GUTTER, TYPE B-6.12
- ③ EXISTING HOT-MIX ASPHALT SURFACE ± 6"
- ④ EXISTING P.C. CONC. BASE COURSE ± 9"
- ⑤ EXISTING HOT-MIX ASPHALT SURFACE OVERLAY AFTER MILLING
- ⑥ PROPOSED HOT-MIX ASPHALT SURFACE REMOVAL - 2½"
- ⑦ PROPOSED POLYMERIZED HOT-MIX ASPHALT SURFACE COURSE, MIX "F", N90, 1¾"
- ⑧ PROPOSED POLYMERIZED LEVELING BINDER (MACHINE METHOD), IL-4.75, N50, ¾"

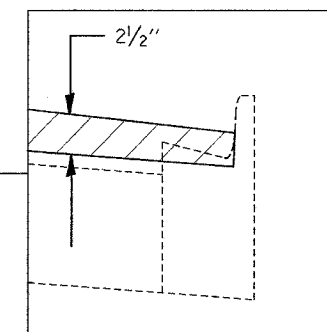

**NOTE:**

REMOVAL OF ANY CONCRETE IS INCLUDED IN THE COST OF HOT-MIX ASPHALT SURFACE REMOVAL 2½"

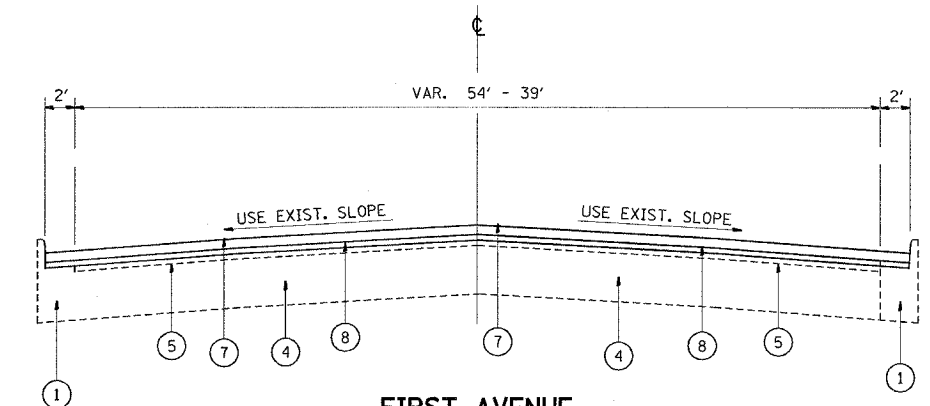

**FIRST AVENUE**  
PROPOSED TYPICAL CROSS SECTION  
( FROM STATIONS 26+22 TO 61+06 )

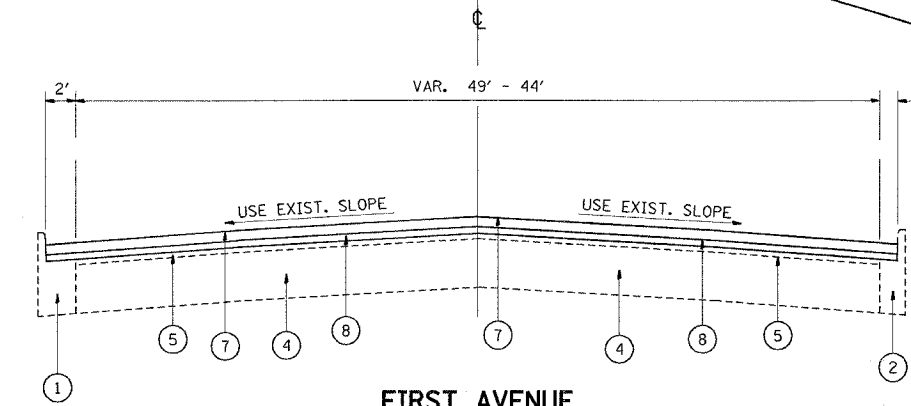

**FIRST AVENUE**  
PROPOSED TYPICAL CROSS SECTION  
( FROM STATIONS 61+06 TO 85+00 )

**HMA MIXTURE REQUIREMENTS**

MIXTURE USE	AC/PG	AIR VOIDS (%)
POLYMERIZED HOT-MIX ASPHALT SURFACE COURSE, MIX "F", N90 (IL 9.5 MM)	SBS/SBR PG 70-22	4% @ 90 GYR.
POLYMERIZED LEVELING BINDER (MACHINE METHOD), IL-4.75, N50	SBS/SBR PG 76-28/-22	4% @ 50 GYR.
ALL CLASS D PATCHES (HMA BINDER IL-19MM)	PG 64-22*	4% @ 70 GYR.
HMA REPLACEMENT OVER PATCHES (HMA BINDER IL-19 MM)	PG 64-22*	4% @ 70 GYR.
DRIVEWAYS HOT-MIX ASPHALT SURFACE COURSE, MIX "C", N50, 2" (IL 9.5 MM)	PG 64-22	4% @ 50 GYR.
DRIVEWAYS HOT-MIX ASPHALT BASE COURSE, 8" (HMA BINDER IL-19 MM)	PG 64-22*	4% @ 50 GYR.
THE UNIT WEIGHT USED TO CALCULATE ALL HMA SURFACE MIXTURE QUANTITIES IS 112 LBS/SY/IN		
* WHEN RAP EXCEEDS 20%, THE NEW ASPHALT BINDER IN THE MIX SHALL BE PG 58-22		

REVISIONS	
NAME	DATE

ILLINOIS DEPARTMENT OF TRANSPORTATION  
IL-171 (1ST AVENUE)  
I-290 TO LAKE ST.  
**TYPICAL CROSS SECTION**

SCALE: VERT. NONE  
HORIZ. NONE  
DATE OCT. 24, 2006

DRAWN BY FRITZ  
CHECKED BY

P. A. U. NO.	SECTION	COUNTY	TOTAL SHEETS	SHEET NO.
1419	3091-RS-4	COOK	27	6
STA.	TO STA.			
FED. ROAD DIST. NO.	ILLINOIS	FED. AID PROJECT		

C62728

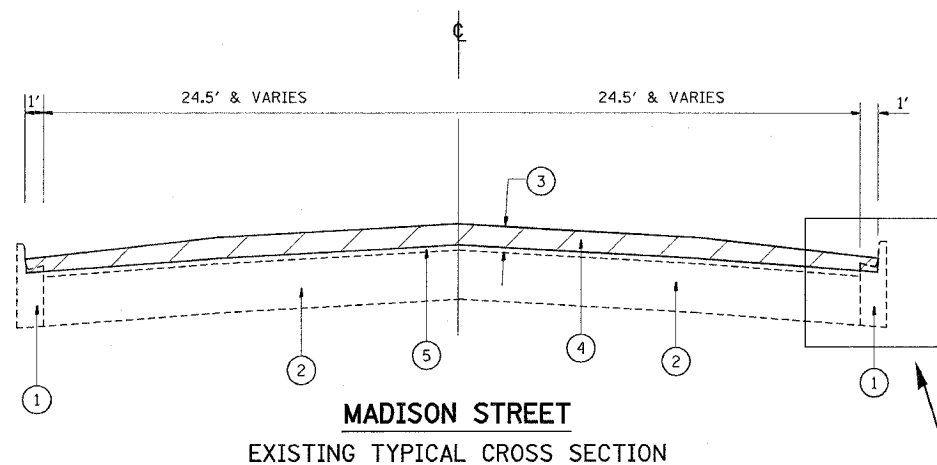

**MADISON STREET**  
EXISTING TYPICAL CROSS SECTION

**LEGEND :**

- ① EXISTING COMB. CONC. CURB & GUTTER, TYPE B-6.12
- ② EXISTING P.C. CONC. BASE COURSE ± 9"
- ③ EXISTING HOT-MIX ASPHALT SURFACE ± 4"
- ④ PROPOSED HOT-MIX ASPHALT SURFACE REMOVAL, 2 1/4"
- ⑤ EXISTING HOT-MIX ASPHALT SURFACE OVERLAY AFTER MILLING
- ⑥ PROPOSED POLYMERIZED LEVELING BINDER (MACHINE METHOD), IL-4.75, N50, 3/4"
- ⑦ PROPOSED HOT-MIX ASPHALT SURFACE COURSE, MIX "D", N70, 1 1/2"

**NOTE:**

REMOVAL OF ANY CONCRETE IS INCLUDED IN THE COST OF HOT-MIX ASPHALT SURFACE REMOVAL 2 1/4"

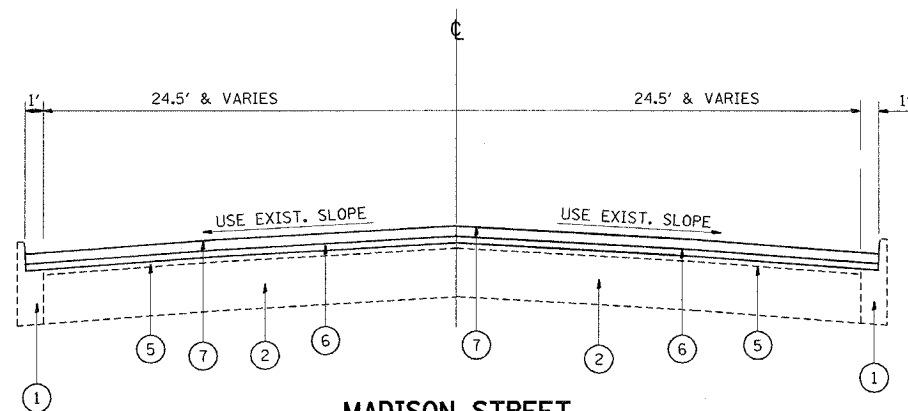
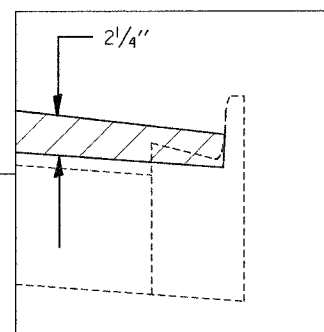

**MADISON STREET**  
PROPOSED TYPICAL CROSS SECTION

BITUMINOUS MIXTURE REQUIREMENTS

MIXTURE USE	AC/PG	AIR VOIDS (%)
HOT-MIX ASPHALT SURFACE COURSE, MIX "D", N70 ( IL 9.5 MM)	PG 64-22	4% @ 70 GYR.
POLYMERIZED LEVELING BINDER (MACHINE METHOD), IL-4.75, N50	SBS/SBR PG 76-28/-22	4% @ 50 GYR.
ALL CLASS D PATCHES (HMA BINDER IL-19MM)	PG 64-22 *	4% @ 70 GYR.
HMA REPLACEMENT OVER PATCHES (HMA BINDER IL-19MM)	PG 64-22 *	4% @ 70 GYR.

THE UNIT WEIGHT USED TO CALCULATE ALL HMA SURFACE MIXTURE QUANTITIES IS 112 LBS/SY/IN  
\* WHEN RAP EXCEEDS 20%, THE NEW ASPHALT BINDER IN THE MIX SHALL BE PG 58-22

REVISIONS	
NAME	DATE

ILLINOIS DEPARTMENT OF TRANSPORTATION  
**MADISON STREET**  
FIRST AVE. TO DES PLAINES RIVER  
**TYPICAL CROSS SECTION**

SCALE: VERT. NONE  
HORIZ. NONE  
DATE OCT. 24, 2006

DRAWN BY FRITZ  
CHECKED BY

F. & U. RITE.	SECTION	COUNTY	TOTAL SHEETS	SHEET NO.
372	3091 RS-4	COOK	27	7
STA.	26+20	TO STA.	85+00	
FED. ROAD DIST. NO.	ILLINOIS	FED. AID PROJECT		

C62728

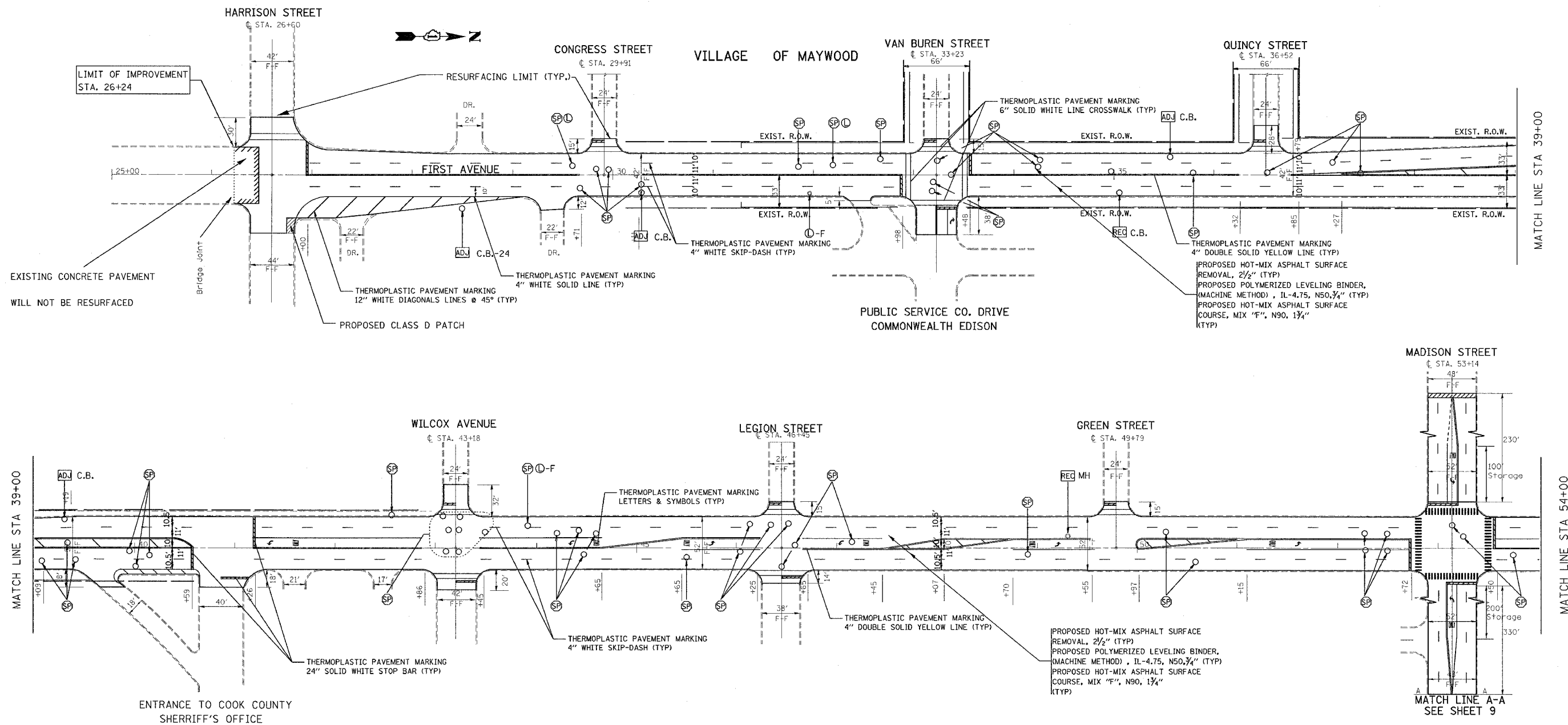

**NOTE:**

1. ALL PAVEMENT MARKING SHALL BE THERMOPLASTIC UNLESS OTHERWISE NOTED. SEE DISTRICT DETAIL TC-13.
2. RAISED REFLECTIVE PAVEMENT MARKERS SHALL BE USED THROUGHOUT THE IMPROVEMENT LIMITS. DOUBLE LANE LINE MARKERS SHALL BE INSTALLED, SEE DIST. DETAIL TC-11.

REVISIONS	
NAME	DATE

ILLINOIS DEPARTMENT OF TRANSPORTATION  
 IL-171 (1ST AVENUE)  
 I-290 TO LAKE ST.  
**PLAN SHEET**

SCALE: VERT. NONE  
 HORIZ. DATE APRIL 9, 2004

DRAWN BY S.E.S.  
 CHECKED BY R.W.

3-FEB-89 14:07:20  
 ZF4C10101610134688AADDGNI  
 LEVELS = 38

P.A. RTE.	SECTION	COUNTY	TOTAL SHEETS	SHEET NO.
372	3091-RS-4	COOK	27	8
STA.	26+20	TO STA.	85+00	
FED. ROAD DIST. NO.	ILLINOIS	FED. AID PROJECT		

C62728

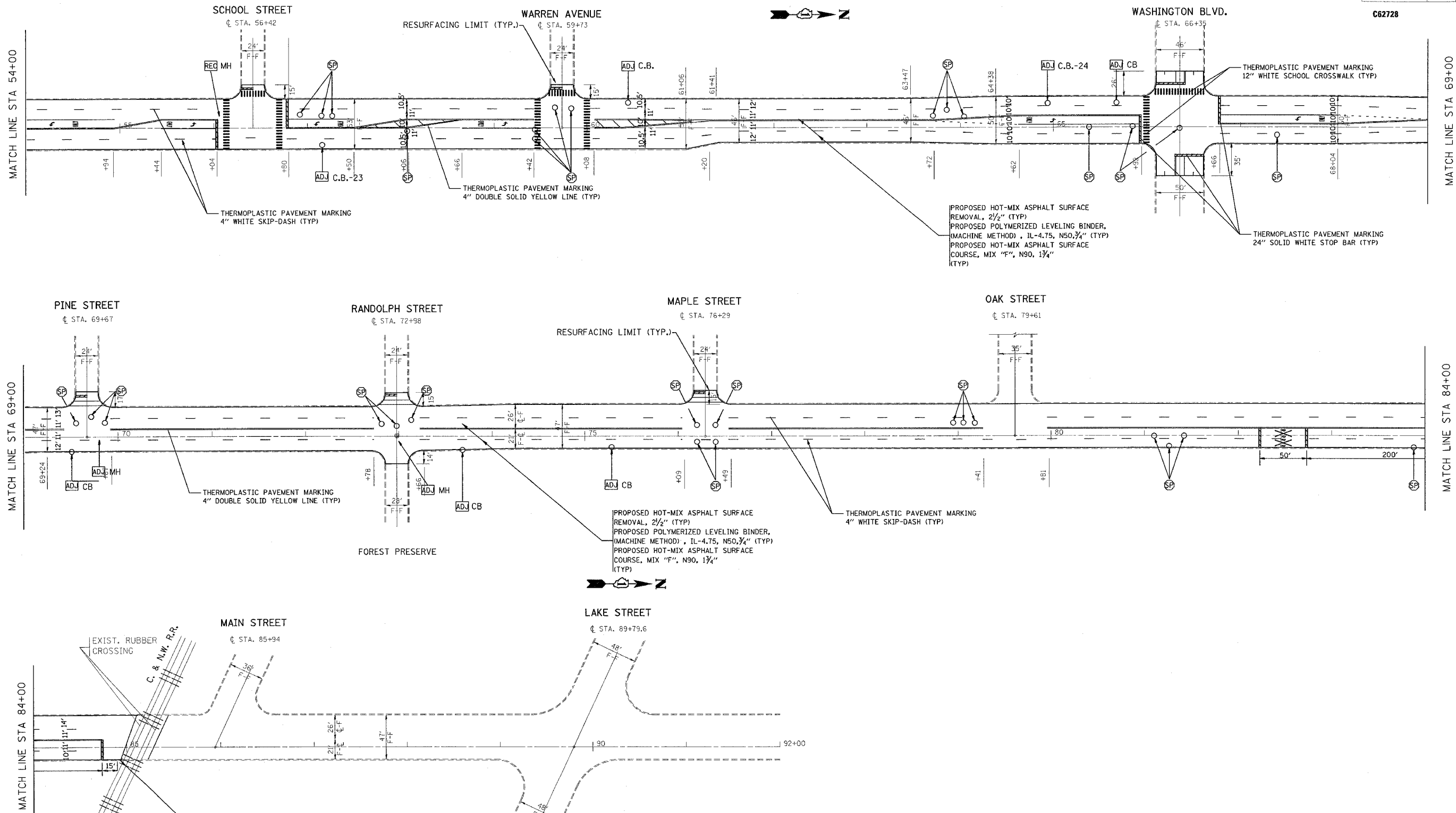

- NOTE:**
1. ALL PAVEMENT MARKING SHALL BE THERMOPLASTIC UNLESS OTHERWISE NOTED. SEE DISTRICT DETAIL TC-13.
  2. RAISED REFLECTIVE PAVEMENT MARKERS SHALL BE USED THROUGHOUT THE IMPROVEMENT LIMITS. DOUBLE LANE LINE MARKERS SHALL BE INSTALLED, SEE DIST. DETAIL TC-11.

REVISIONS	
NAME	DATE

ILLINOIS DEPARTMENT OF TRANSPORTATION  
**IL-171 (1ST AVENUE)**  
**I-290 TO LAKE ST.**  
**PLAN SHEET**

SCALE: VERT. NONE  
 HORIZ. NONE  
 DATE APRIL 9, 2004

DRAWN BY S.E.S.  
 CHECKED BY R.W.

3-FEB-09 14:07:20  
 ZF4C10.016JDI34688A4DGN1  
 LEVELS = 35



P. & U. RITE.	SECTION	COUNTY	TOTAL SHEETS	SHEET NO.
372	3091 RS-4	COOK	27	9
STA.		TO STA.		
FED. ROAD DIST. NO.		ILLINOIS	FED. AID PROJECT	

C62728

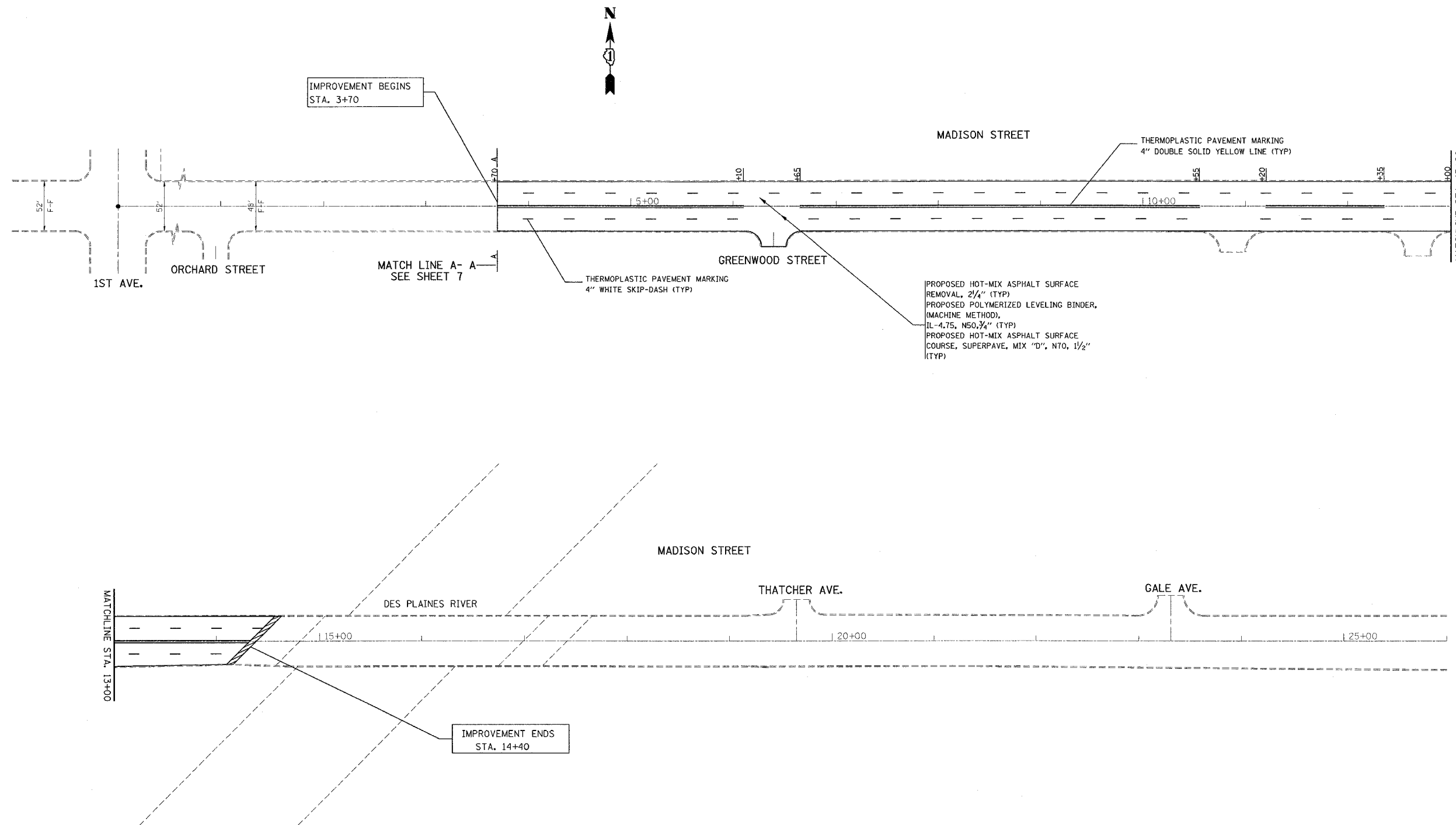

3-FEB-89 14:57:20  
 ZF4C110,016,0134688A.DGN1  
 LEVELS = 35

VI - TYP

REVISIONS	
NAME	DATE

ILLINOIS DEPARTMENT OF TRANSPORTATION

**MADISON STREET  
 FIRST AVE. TO DES PLAINES RIVER  
 PROPOSED ROADWAY & PAVEMENT  
 MARKINGS PLANS**

SCALE: VERT. NONE  
 HORIZ. NONE

DATE NOV. 4, 2006

DRAWN BY FRITZ  
 CHECKED BY R.W.

C 62728

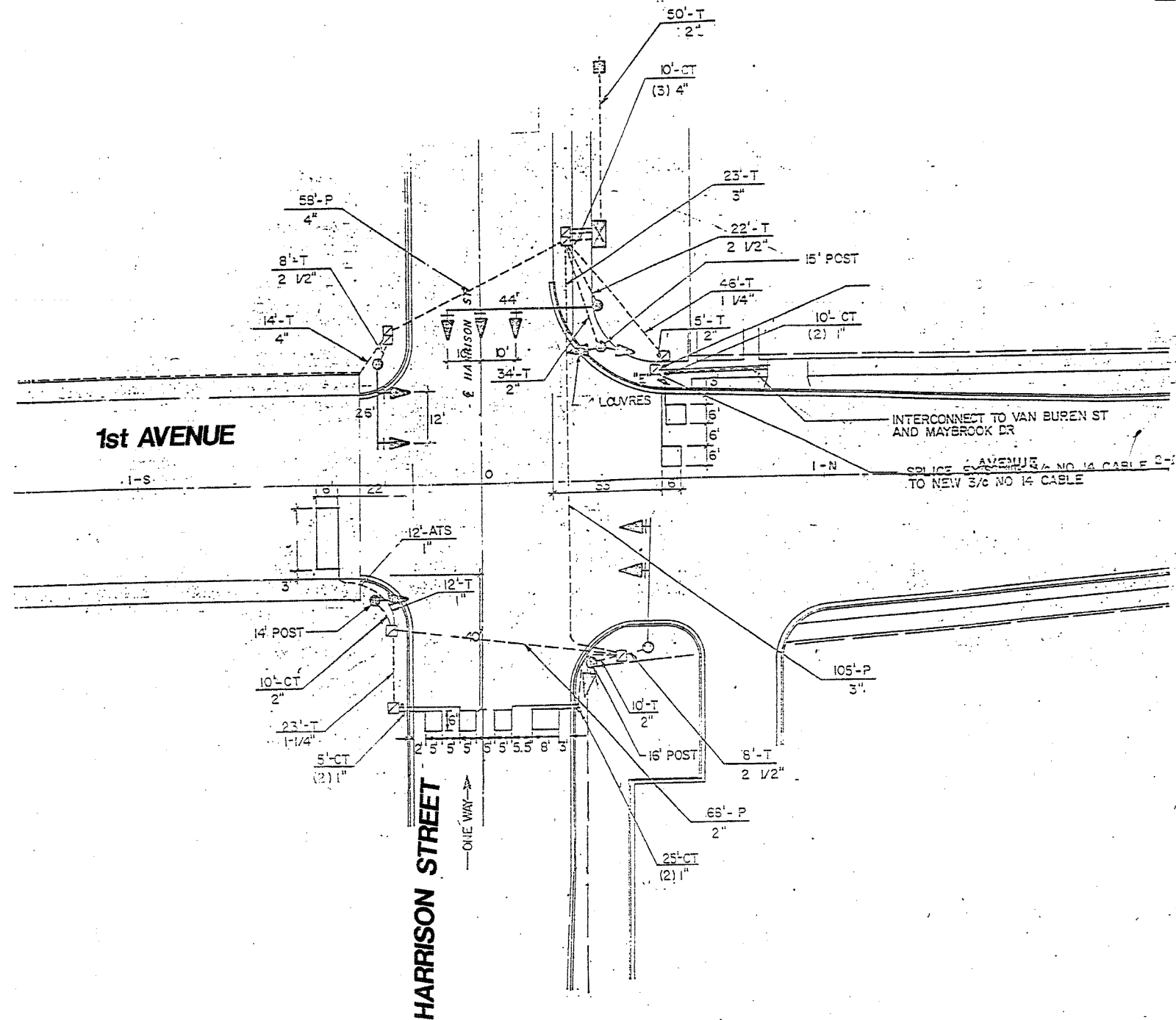

**REPLACE ALL DETECTOR LOOPS AS SHOWN  
(WITHIN THE RESURFACING LIMITS)**

CODE NO.	QUANTITY	UNIT	ITEM
88600600	66'	FOOT	DETECTOR LOOP REPLACEMENT

**NOTE:**  
THIS PLAN IS FOR THE PURPOSE OF REPLACING THE DETECTOR LOOPS. ALL OTHER INFORMATION SHOWN IS NOT RELATED AND WILL BE DISREGARDED.



ILLINOIS DEPARTMENT OF TRANSPORTATION  
**DETECTOR LOOPS AT:  
1st AVENUE &  
HARRISON STREET**

SCALE: T= DATE  
DESIGNED BY: DRAWN BY: CHECKED BY:

C 62728

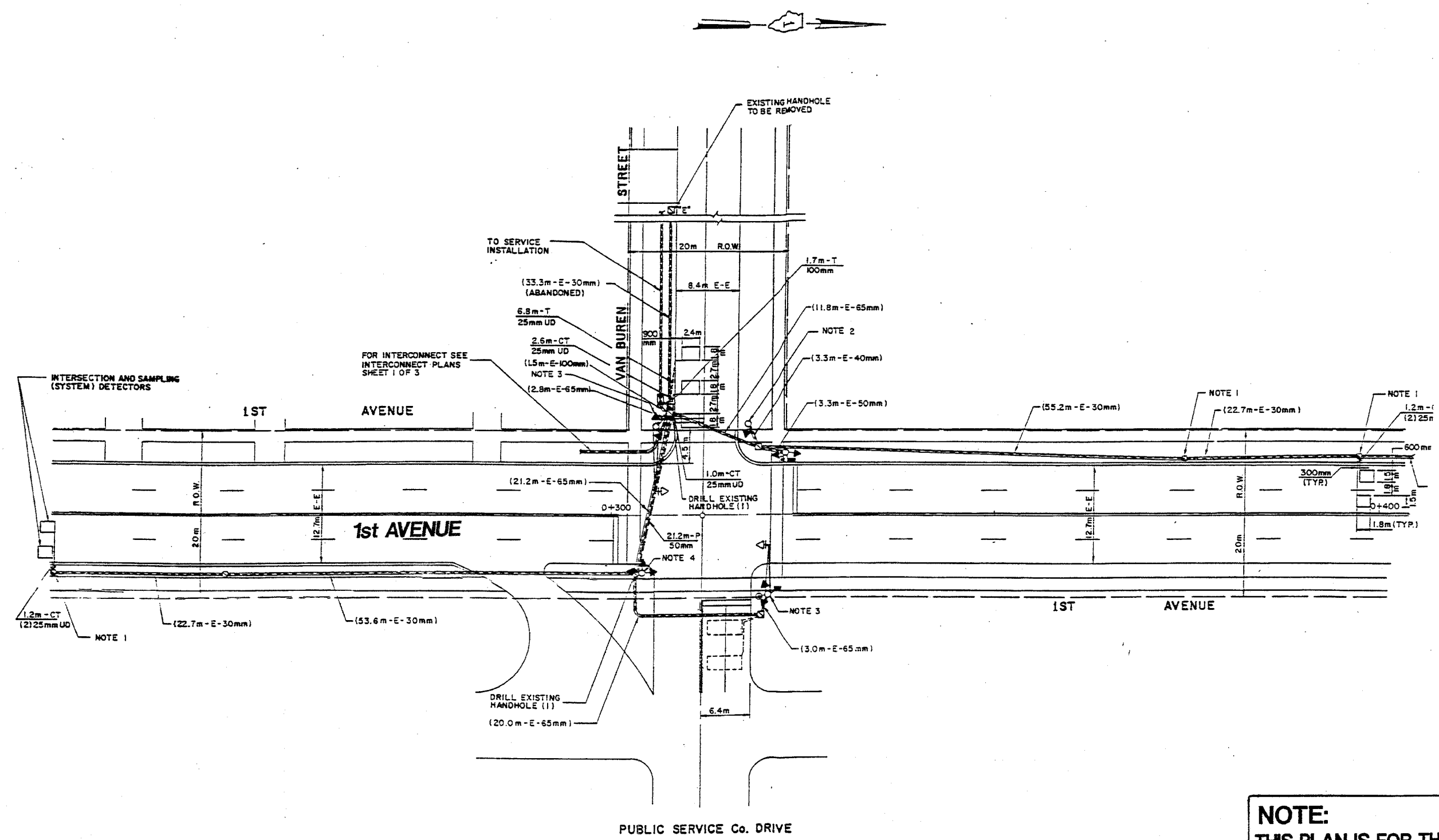

**NOTE:**  
 THIS PLAN IS FOR THE PURPOSE OF REPLACING THE DETECTOR LOOPS. ALL OTHER INFORMATION SHOWN IS NOT RELATED AND WILL BE DISREGARDED.



ILLINOIS DEPARTMENT OF TRANSPORTATION  
 DETECTOR LOOPS AT:  
 1st AVENUE  
 VAN BUREN STREET

**REPLACE ALL DETECTOR LOOPS AS SHOWN**

(WITHIN THE RESURFACING LIMITS)

CODE NO.	QUANTITY	UNIT	ITEM
88600600	261'	FOOT	DETECTOR LOOP REPLACEMENT

SCALE: 1"=  
 DATE

DESIGNED BY:  
 DRAWN BY:  
 CHECKED BY:

C 62728

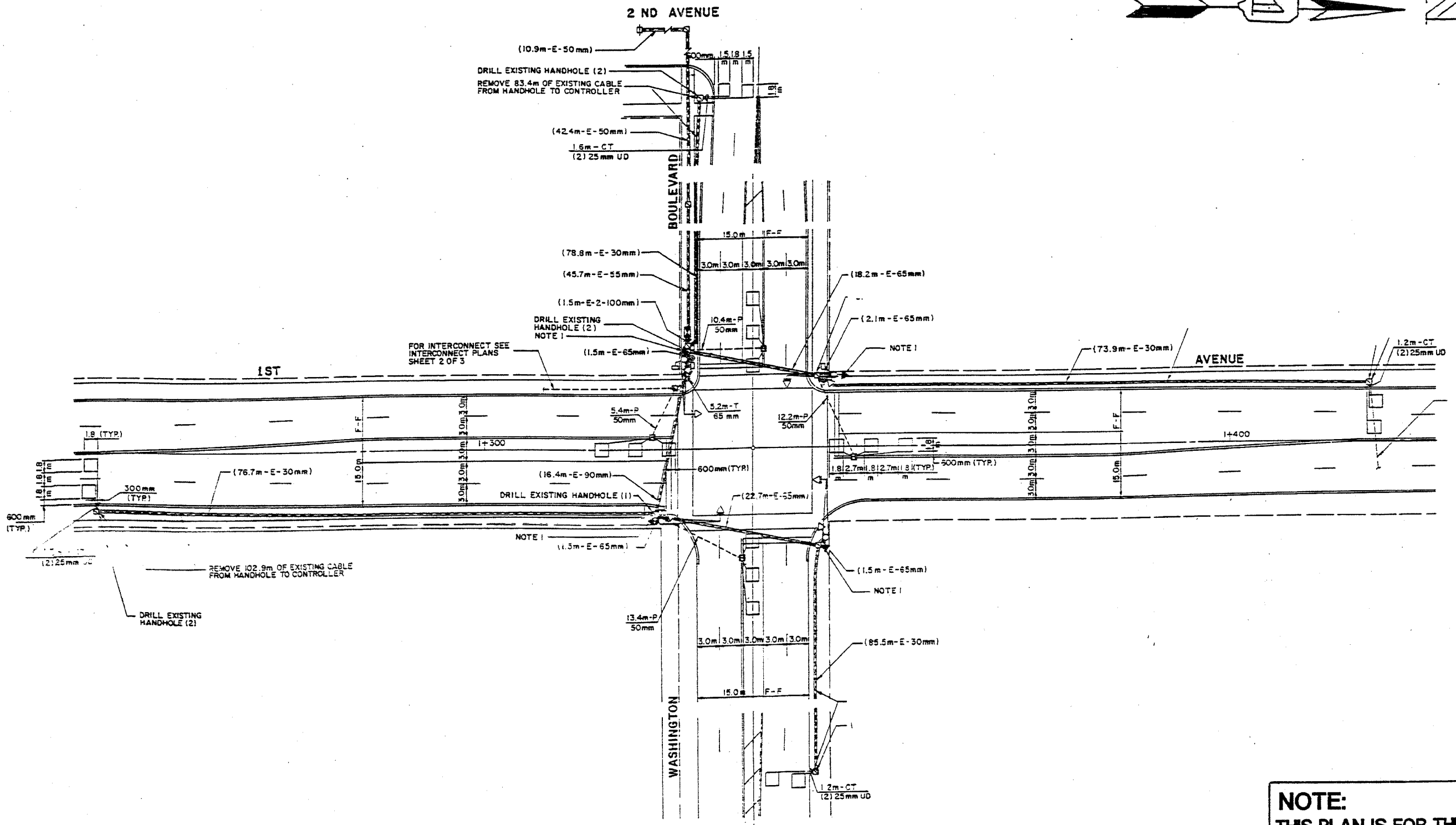
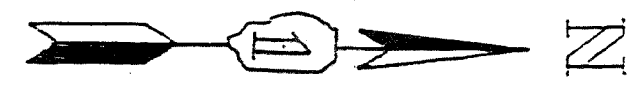

**REPLACE ALL DETECTOR LOOPS AS SHOWN**

(WITHIN THE RESURFACING LIMITS)

CODE NO.	QUANTITY	UNIT	ITEM
88600600	436'	FOOT	DETECTOR LOOP REPLACEMENT

**NOTE:**  
THIS PLAN IS FOR THE PURPOSE OF REPLACING THE DETECTOR LOOPS. ALL OTHER INFORMATION SHOWN IS NOT RELATED AND WILL BE DISREGARDED.



ILLINOIS DEPARTMENT OF TRANSPORTATION  
**DETECTOR LOOPS AT:**  
**1st AVENUE &**  
**WASHINGTON BLVD.**

SCALE: T=  
DATE  
DESIGNED BY:  
DRAWN BY:  
CHECKED BY:

C 62728

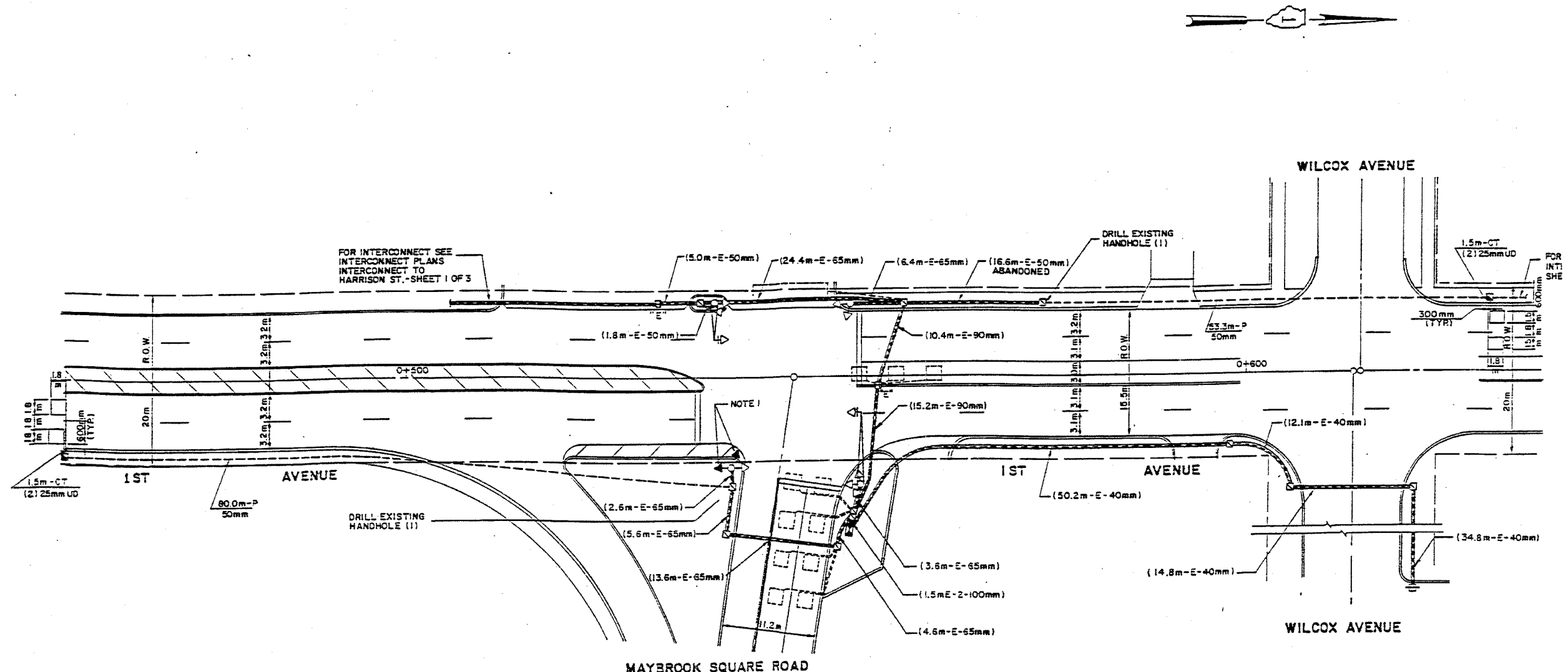

**REPLACE ALL DETECTOR LOOPS AS SHOWN**

(WITHIN THE RESURFACING LIMITS)

CODE NO.	QUANTITY	UNIT	ITEM
88600600	286'	FOOT	DETECTOR LOOP REPLACEMENT

**NOTE:**  
THIS PLAN IS FOR THE PURPOSE OF REPLACING THE DETECTOR LOOPS; ALL OTHER INFORMATION SHOWN IS NOT RELATED AND WILL BE DISREGARDED.



SCALE: 1" =  
DATE

DESIGNED BY:  
DRAWN BY:  
CHECKED BY:

ILLINOIS DEPARTMENT OF TRANSPORTATION  
DETECTOR LOOPS AT:  
1st AVENUE &  
MAYBROOK SQ. ROAD

SECTION	COUNTY	TOTAL SHEETS	SHEET NO.
372 3091-RS-4	COOK	27	14
STA. TO STA.		FED. AID PROJECT	

C62728

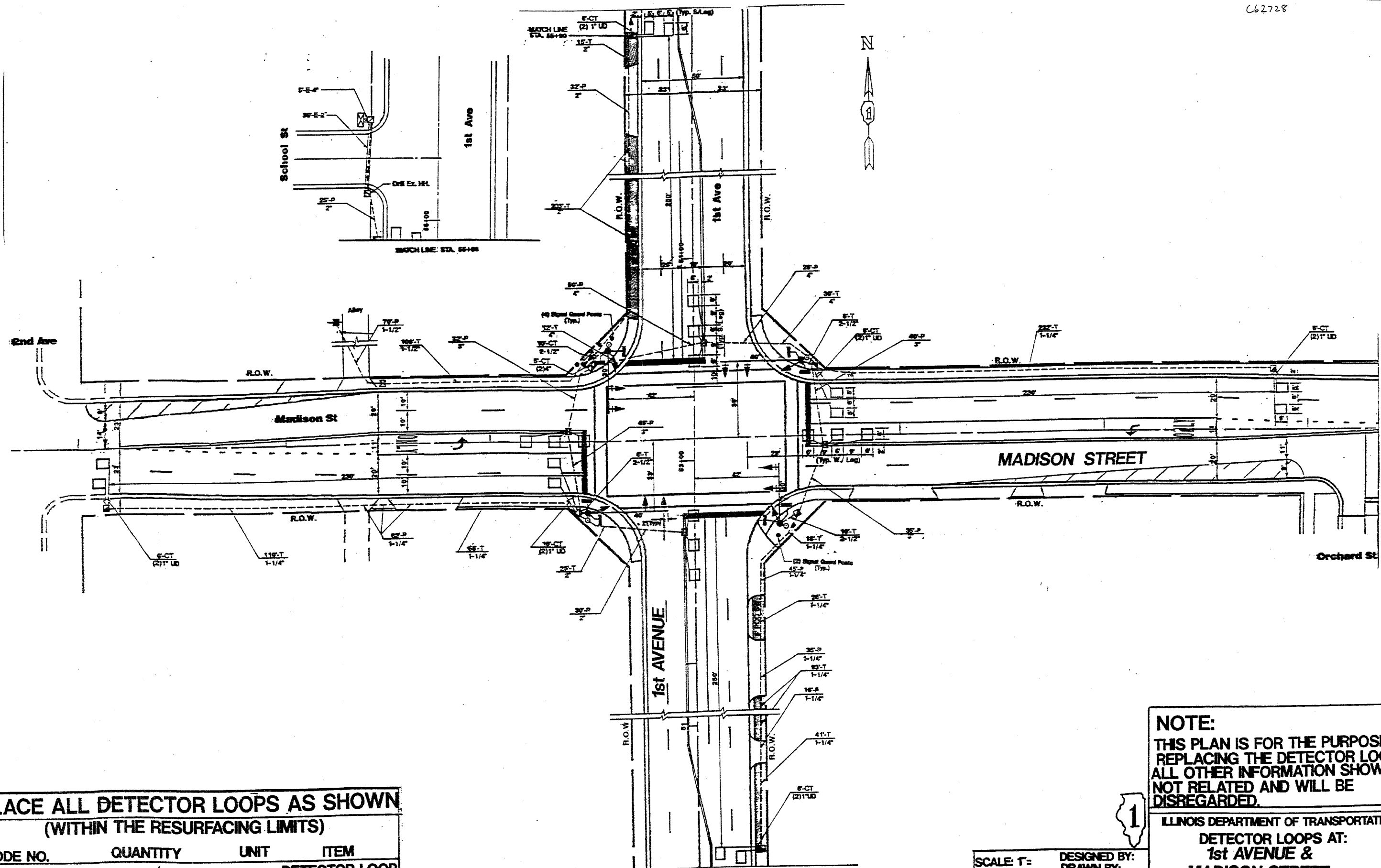

**REPLACE ALL DETECTOR LOOPS AS SHOWN**

(WITHIN THE RESURFACING LIMITS)

CODE NO.	QUANTITY	UNIT	ITEM
88600600	678'	FOOT	DETECTOR LOOP REPLACEMENT

**NOTE:**  
THIS PLAN IS FOR THE PURPOSE OF REPLACING THE DETECTOR LOOPS. ALL OTHER INFORMATION SHOWN IS NOT RELATED AND WILL BE DISREGARDED.

1

ILLINOIS DEPARTMENT OF TRANSPORTATION  
DETECTOR LOOPS AT:  
**1st AVENUE & MADISON STREET**

SCALE: T= DATE  
DESIGNED BY: DRAWN BY: CHECKED BY:

T & E SHEET NO.	SECTION	COUNTY	TOTAL SHEETS	SHEET NO.
372	3091 RS-4	Cook	27	15
STA.		TO STA.		
FED. ROAD DIST NO. 7		ILLINOIS	FED. AID PROJECT	

C62728

**TRAFFIC SIGNAL LEGEND**

	PROPOSED	EXISTING
CONTROLLER CABINET	[Symbol]	[Symbol]
RAILROAD CONTROL CABINET	[Symbol]	[Symbol]
SERVICE INSTALLATION, (P) POLE OR (G) GROUND MOUNT	[Symbol]	[Symbol]
TELEPHONE CONNECTION	[Symbol]	[Symbol]
SIGNAL HEAD	[Symbol]	[Symbol]
SIGNAL HEAD WITH BACKPLATE	[Symbol]	[Symbol]
SIGNAL HEAD OPTICALLY PROGRAMMED	[Symbol]	[Symbol]
SIGNAL HEAD PEDESTRIAN	[Symbol]	[Symbol]
ILLUMINATED SIGN "NO LEFT TURN"	[Symbol]	[Symbol]
ILLUMINATED SIGN "NO RIGHT TURN"	[Symbol]	[Symbol]
SIGNAL POST	[Symbol]	[Symbol]
WOOD POLE	[Symbol]	[Symbol]
STEEL MAST ARM ASSEMBLY AND POLE	[Symbol]	[Symbol]
MAST ARM ASSEMBLY AND POLE, ALUMINUM	[Symbol]	[Symbol]
STEEL COMBINATION MAST ARM ASSEMBLY AND POLE WITH LUMINAIRE	[Symbol]	[Symbol]
JUNCTION BOX	[Symbol]	[Symbol]
HANDHOLE	[Symbol]	[Symbol]
HEAVY DUTY HANDHOLE	[Symbol]	[Symbol]
DOUBLE HANDHOLE	[Symbol]	[Symbol]
G.S. CONDUIT IN TRENCH OR PUSHED	[Symbol]	[Symbol]
COMMON TRENCH	[Symbol]	[Symbol]
UNIT DUCT	[Symbol]	[Symbol]

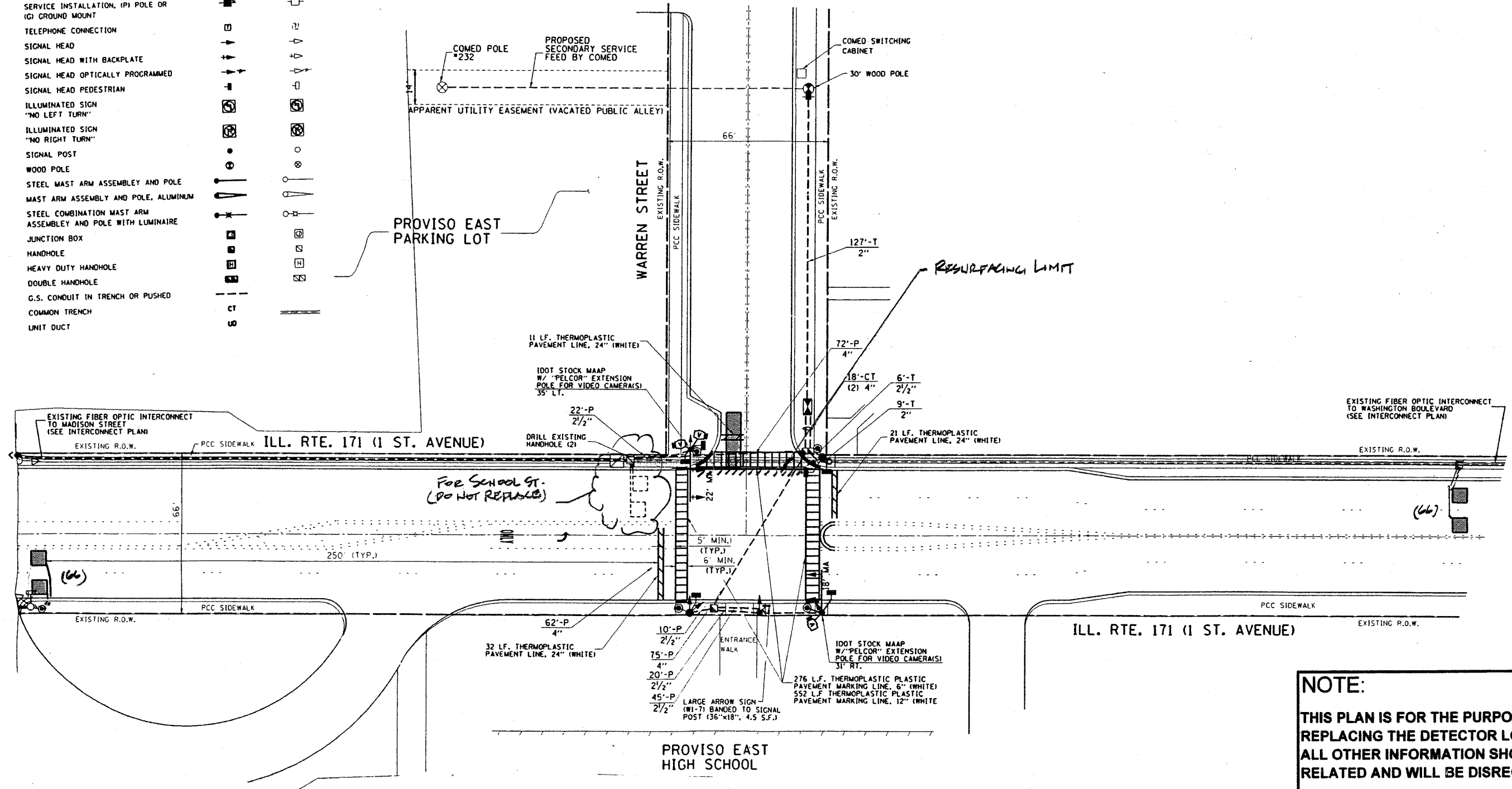

**REPLACE ALL DETECTOR LOOPS AS SHOWN**  
(WITHIN THE RESURFACING LIMITS)

CODE NO.	QUANTITY	UNIT	ITEM
86600600	132	Foot	Detector Loop Replacement

REVISIONS	
NAME	DATE

**NOTE:**  
THIS PLAN IS FOR THE PURPOSE OF REPLACING THE DETECTOR LOOPS ONLY. ALL OTHER INFORMATION SHOWN IS NOT RELATED AND WILL BE DISREGARDED.

ILLINOIS DEPARTMENT OF TRANSPORTATION  
**DETECTOR LOOP REPLACEMENT**  
1st Avenue @ Warren Street  
SCALE None  
DATE Nov. 2006  
DRAWN BY J.H.E.  
DESIGNED BY J.H.E.  
CHECKED BY D.A.D.

F.A.P. RTE.	SECTION	COUNTY	TOTAL SHEETS	SHEET NO.
372	3091 RS-4	COOK	27	16
STA.		TO STA.		
FED. ROAD DIST. NO. 1 ILLINOIS FED. AID PROJECT				

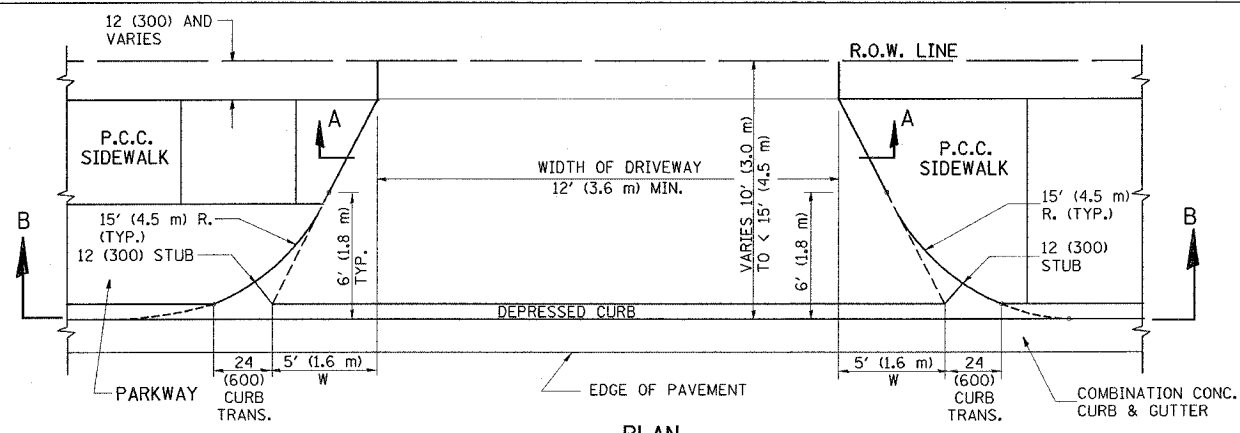

PLAN  
10' (3.0 m) TO < 15' (4.5 m)

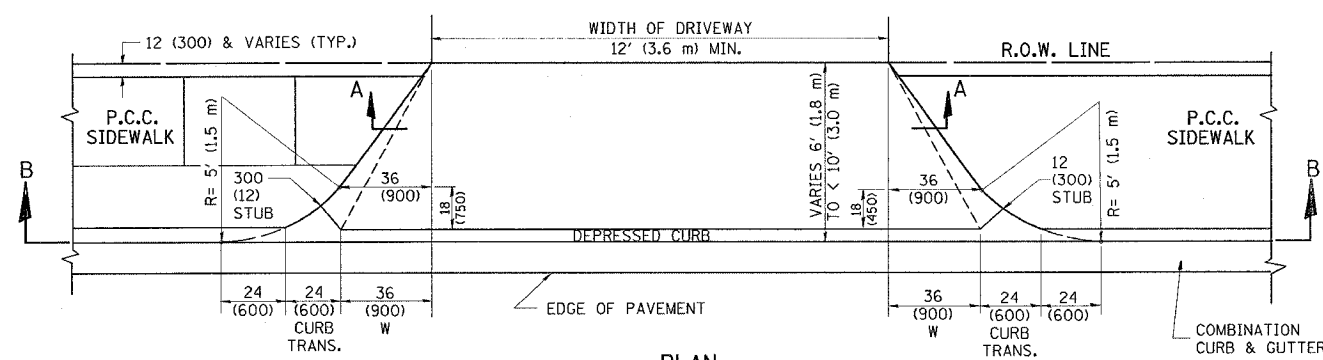

PLAN  
6' (1.8 m) TO < 10' (3.0 m)

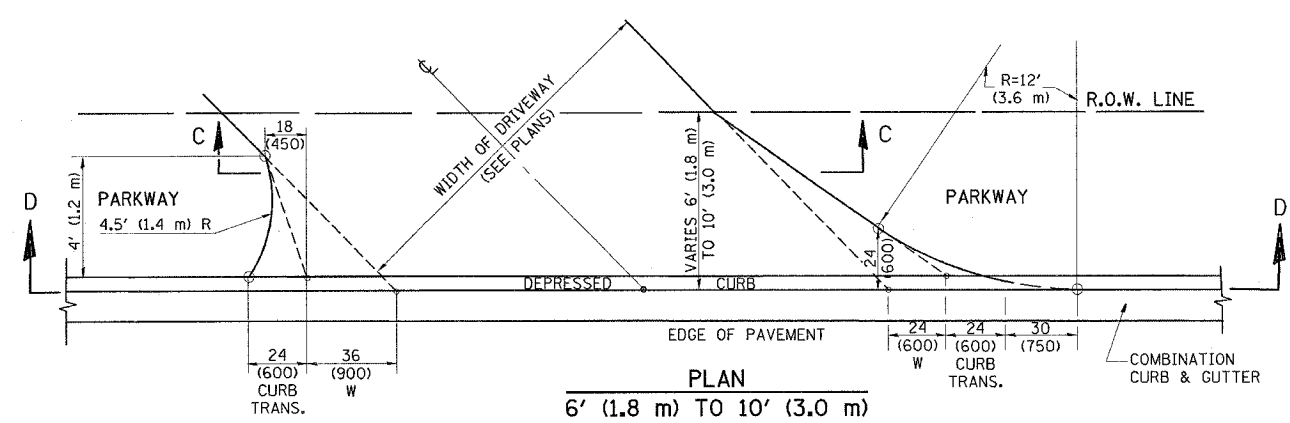

PLAN  
6' (1.8 m) TO 10' (3.0 m)

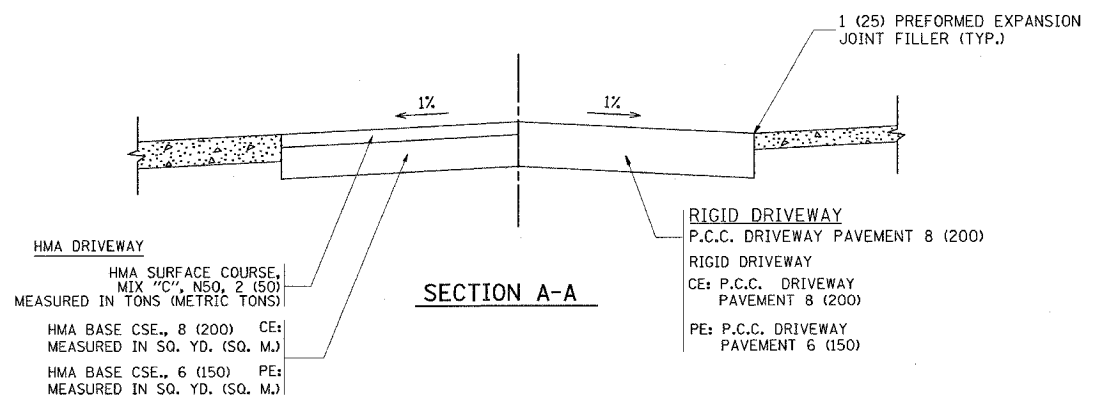

HMA DRIVEWAY  
HMA SURFACE COURSE, MIX "C", NSO, 2 (50) MEASURED IN TONS (METRIC TONS)  
HMA BASE CSE., 8 (200) CE: MEASURED IN SQ. YD. (SQ. M.)  
HMA BASE CSE., 6 (150) PE: MEASURED IN SQ. YD. (SQ. M.)

RIGID DRIVEWAY  
P.C.C. DRIVEWAY PAVEMENT 8 (200)  
RIGID DRIVEWAY  
CE: P.C.C. DRIVEWAY PAVEMENT 8 (200)  
PE: P.C.C. DRIVEWAY PAVEMENT 6 (150)

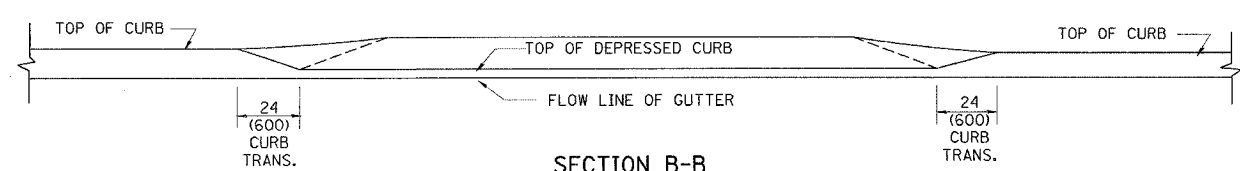

SECTION B-B

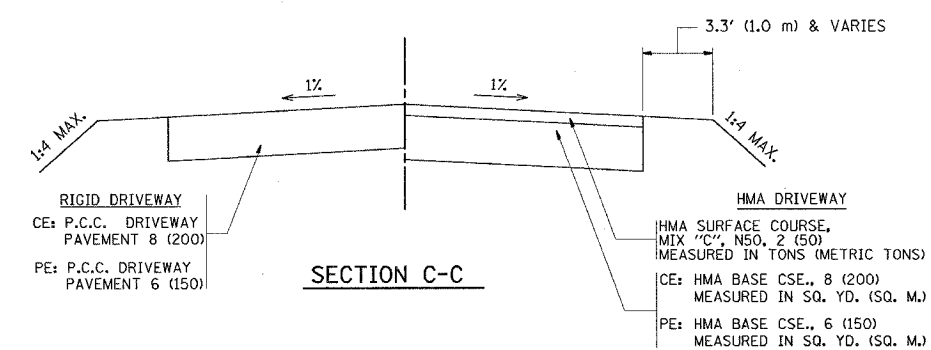

SECTION C-C

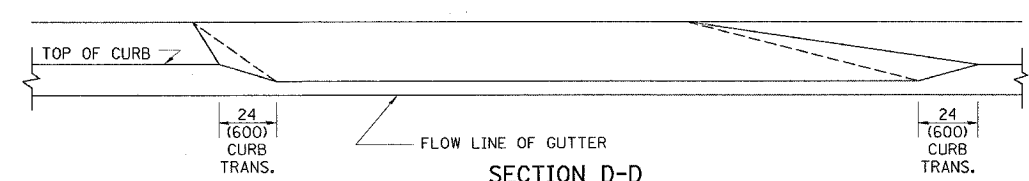

SECTION D-D

GENERAL NOTES

DRIVEWAY SLOPES, LOCATIONS, & GEOMETRIC LAYOUT SHALL BE IN ACCORDANCE WITH THE LATEST EDITION OF THE "HANDBOOK FOR POLICY ON PERMITS FOR ACCESS DRIVEWAYS TO STATE HIGHWAYS". FOR FURTHER LAYOUT REQUIREMENTS, REFER TO ILLUSTRATION 10 IN THE PERMIT HANDBOOK. WHERE SIDEWALKS EXIST, DRIVEWAYS SHALL BE REPLACED WITH RIGID PAVEMENT. WHERE NO SIDEWALKS EXIST, DRIVEWAYS SHALL BE REPLACED IN KIND. SIDEWALK CROSS SLOPE THRU DRIVEWAY AREA TO BE A MAXIMUM OF 1:50.

WHEN THE DISTANCE BETWEEN R.O.W. AND THE BACK OF CURB IS EQUAL TO OR LESS THAN 8' (2.4 m), THE P.C.C. SIDEWALK SHALL EXTEND TO THE BACK OF CURB.

THE RESIDENT ENGINEER SHALL CONTACT THE TRAFFIC PERMIT OFFICE AT 847/ 705-4131 FOR ANY QUESTIONS ON DRIVEWAYS SHOWN IN THE PLANS; SPECIFICALLY IN REFERENCE TO ADDITIONAL AND/OR RELOCATION/REMOVAL OF A DRIVEWAY.

COMBINATION CONCRETE CURB & GUTTER SHALL BE MEASURED STRAIGHT ACROSS THE DRIVEWAY. NO ADDITIONAL COMPENSATION WILL BE ALLOWED FOR THE CURB & GUTTER TRANSITION.

THE 1 (25) PREFORMED EXPANSION JOINT FILLER WILL NOT BE PAID SEPARATELY, BUT SHALL BE CONSIDERED INCLUDED IN THE COST OF THE P.C.C. DRIVEWAY PAVEMENT OR P.C.C. SIDEWALK.

"W" VARIES FROM 36 (900) TO 5' (1.5 m) PROPORTIONAL TO THE LENGTH (L), FROM 6' (1.8 m) TO 10' (3 m).

ALL DIMENSIONS ARE IN INCHES (MILLIMETERS) UNLESS OTHERWISE NOTED.

REVISIONS	
NAME	DATE
R. SHAH	11/06/95
J. POLLASTRINI	08/12/96
J. POLLASTRINI	12/14/96
A. ABBAS	03/21/97
T. HOLTZ	04/08/97
M. GOMEZ	04/06/01
P. LAFLEUR	04/15/03
R. BORO	01/01/07

ILLINOIS DEPARTMENT OF TRANSPORTATION

DRIVEWAY DETAILS  
DISTANCE BETWEEN ROW AND FACE OF CURB < 15' (4.5 m)

SCALE: VERT. HORIZ. DATE PLOTTED 4/21/2006

DRAWN BY CHECKED BY

PLOT DATE = 12/21/2006  
FILE NAME = A:\Users\gull\Documents\2006\bd400\bd400.dwg  
USER = gull



F.A.U. RTE.	SECTION	COUNTY	TOTAL SHEETS	SHEET NO.
372	3091 RS-4	COOK	27	17
STA.		TO STA.		
FED. ROAD DIST. NO. 1 ILLINOIS FED. AID PROJECT				

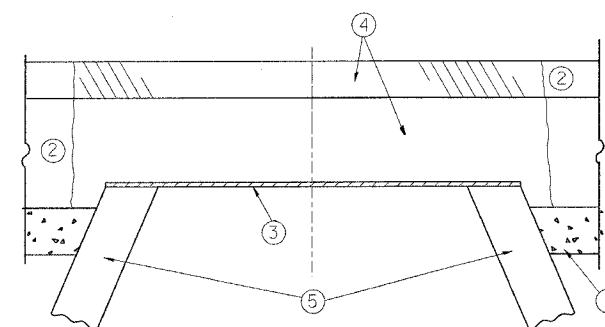

CONSTRUCTION PROCEDURES

STAGE 1 (BEFORE PAVEMENT MILLING)

- A) REMOVE A MINIMUM OF 12 (300) OF THE PAVEMENT FROM AROUND THE STRUCTURE.
- B) REMOVE THE EXISTING FRAME AND LID FROM THE STRUCTURE.
- C) COVER THE STRUCTURE OPENING WITH A 36 (900) DIAMETER METAL PLATE.
- D) BACKFILL WITH CRUSHED STONE AND A MINIMUM 1 1/2 (40) THICK HMA SURFACE MIX APPROVED BY THE ENGINEER.

STAGE 2 (AFTER PAVEMENT MILLING)

- A) REMOVE THE HMA SURFACE MIX AND CRUSHED STONE.
- B) INSTALL THE FRAME AND LID; ADJUST THE FRAME TO ITS FINAL SURFACE ELEVATION.
- C) THE SURROUNDING SPACE SHALL BE FILLED WITH CLASS SI CONCRETE, OR HMA SURFACE COURSE OR HMA BINDER COURSE TO THE ELEVATION OF THE SURFACE OF THE EXISTING BASE COURSE OR THE BINDER COURSE.

THE PROCEDURE EXPLAINED ABOVE SHALL CONFORM TO THE APPLICABLE PORTIONS OF SECTIONS 353, 406, 602, AND 603 OF THE STANDARD SPECIFICATIONS.

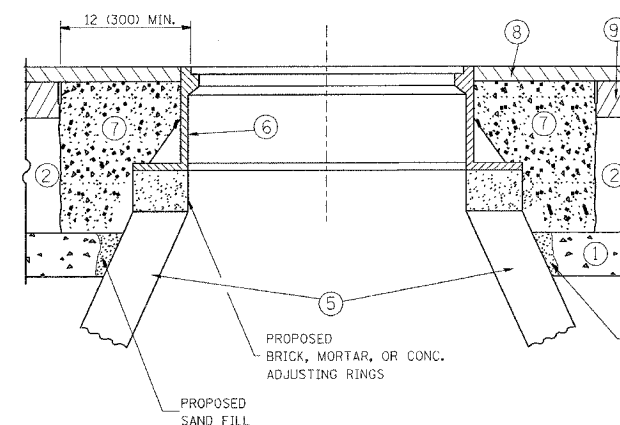

LEGEND

- ① SUB-BASE GRANULAR MATERIAL
- ② EXISTING PAVEMENT
- ③ 36 (900) DIAMETER METAL PLATE
- ④ PROPOSED CRUSHED STONE AND HMA SURFACE MIX
- ⑤ EXISTING STRUCTURE
- ⑥ FRAME AND LID (SEE NOTES)
- ⑦ CLASS SI CONCRETE, HMA SURFACE COURSE OR HMA BINDER COURSE
- ⑧ PROPOSED HMA SURFACE COURSE
- ⑨ PROPOSED HMA BINDER COURSE

NOTES:

EXISTING BROKEN FRAMES AND LIDS SHALL BE REMOVED AND DISPOSED OF BY THE CONTRACTOR AND SHALL BE REPLACED AS DIRECTED BY THE ENGINEER. REPLACEMENT FRAMES AND LIDS WILL BE PAID FOR IN ACCORDANCE WITH ARTICLE 109.04 OF THE STANDARD SPECIFICATIONS UNLESS A SEPARATE PAY ITEM HAS BEEN PROVIDED.

IF THE EXISTING LIDS ARE OPEN, THE FRAME WILL BE ADJUSTED TO THE ELEVATION OF THE MILLED PAVEMENT SURFACE PRIOR TO THE MILLING OPERATION. THE FRAME WILL NOT BE REMOVED AND COVERED BY THE METAL PLATE.

CITY OF CHICAGO CASTINGS ARE THE PROPERTY OF THE CITY AND THE CONTRACTOR SHALL NOTIFY THE CITY FOR REMOVAL AND DISPOSITION OF THE CASTINGS.

THE METAL PLATE USED TO COVER THE STRUCTURE SHALL REMAIN THE PROPERTY OF THE CONTRACTOR.

WHEN STRUCTURES ARE TO BE ADJUSTED OR RECONSTRUCTED, THE LOWERING AND RAISING OF THE FRAMES AND LIDS WILL NOT BE PAID FOR SEPARATELY BUT WILL BE INCLUDED IN THE COST OF THE CORRESPONDING PAY ITEM.

LOCATION OF STRUCTURES:

THE CONTRACTOR WILL BE REQUIRED TO KEEP A RECORD OF THE LOCATIONS OF THE BURIED STRUCTURES ACCORDING TO THE STATION AND DISTANCE LEFT OR RIGHT OF THE CENTERLINE OF PAVEMENT. UPON COMPLETION OF THE WORK, THE CONTRACTOR WILL DELIVER THE RECORD TO THE ENGINEER.

BASIS OF PAYMENT: THIS WORK WILL BE PAID FOR AT THE CONTRACT UNIT PRICE PER EACH FOR "FRAMES AND LIDS TO BE ADJUSTED, SPECIAL"

NEW FRAMES AND LIDS, WHEN SPECIFIED, WILL BE PAID FOR SEPARATELY.

DETAILS FOR FRAMES AND LIDS ADJUSTMENT WITH MILLING

ALL DIMENSIONS ARE IN INCHES (MILLIMETERS) UNLESS OTHERWISE SHOWN

REVISIONS	
NAME	DATE
R. SHAH	10/25/94
R. SHAH	01/30/95
R. SHAH	03/10/95
A. ABBAS	03/21/97
R. WIEDEMAN	05/14/04
R. BORO	01/01/07

ILLINOIS DEPARTMENT OF TRANSPORTATION  
DETAILS FOR  
FRAMES AND LIDS ADJUSTMENT  
WITH MILLING

SCALE: VERT. NONE  
HORIZ. NONE  
PLOT DATE: 12/21/2006

DRAWN BY  
CHECKED BY

BD600-03 (BD-8)  
REVISION DATE: 01/01/07



F.A.P. RTE.	SECTION	COUNTY	TOTAL SHEETS	SHEET NO.
372	3091 RS-4	COOK	27	19
STA.		TO STA.		
FED. ROAD DIST. NO. 1		ILLINOIS FED. AID PROJECT		

VARIABLE - TO MEET EXISTING DIMENSIONS AND FIELD CONDITIONS (SEE NOTE ②)

PROP. CONC. CURB OR CURB AND GUTTER REPLACEMENT IN ACCORDANCE WITH STATE STANDARD 606001. (SEE NOTE ②)

SAW CUT FULL DEPTH - INCLUDED IN THE COST OF SIDEWALK, DRIVEWAY OR MEDIAN SURFACE REMOVAL PAY ITEM.

SEE STATE STANDARD 606001

18 (450) MAX.

EXISTING OR PROPOSED HMA SURFACE (IF APPLICABLE)

1/4 (5) \*\*

EXISTING SIDEWALK, DRIVEWAY, MEDIAN SURFACE OR GROUND.

PROPOSED SIDEWALK, DRIVEWAY PAVEMENT, MEDIAN SURFACE OR SALT TOLERANT SOD AND TOP SOIL, 4 (100) SOD RESTORATION (SEE NOTE ①).

EXISTING CONCRETE PAVEMENT, CONCRETE BASE COURSE OR FLEXIBLE PAVEMENT

3 (75) MIN.

SUITABLE BACKFILL MATERIAL (INCLUDED IN THE COST OF CURB OR CURB AND GUTTER REMOVAL AND REPLACEMENT)

PROPOSED 3/4" (20) PREFORMED EXPANSION JOINT AT CONCRETE SIDEWALKS, DRIVEWAYS, AND MEDIANS. (INCLUDED IN THE COST OF CURB OR CURB AND GUTTER REMOVAL AND REPLACEMENT.)

\* 3 (75) MINIMUM FROM TOP AND BOTTOM OF THE CONCRETE PAVEMENT OR BASE COURSE.

\*\* IF THE FINAL SURFACE OF THE PAVEMENT IS CONCRETE, THE GUTTER IS TO BE FLUSH WITH THE PAVEMENT.

NOTE: ① SIDEWALK, DRIVEWAY PAVEMENT OR MEDIAN SURFACE SHALL BE SIMILAR TO THE MATERIAL BEING REMOVED AND WILL BE PAID FOR SEPARATELY.

SALT TOLERANT SOD AND TOP SOIL, 4 (100) RESTORATION WILL NOT BE PAID FOR SEPARATELY, BUT SHALL BE INCLUDED IN THE COST OF CURB OR CURB AND GUTTER REMOVAL AND REPLACEMENT.

② CURB OR CURB AND GUTTER REPLACEMENT SHALL MATCH THE SHAPE OF THE EXISTING CURB OR CURB AND GUTTER UNLESS OTHERWISE SPECIFIED.

③ FOR CURB OR CURB AND GUTTER REMOVAL AND REPLACEMENT ADJACENT TO FLEXIBLE PAVEMENT DELETE EPOXY COATED TIE BARS.

④ LONGITUDINAL BARS, IF ENCOUNTERED IN THE EXISTING CURB OR CURB AND GUTTER, ARE NOT TO BE REPLACED. CUTTING AND REMOVING LONGITUDINAL BARS SHALL BE INCLUDED IN THE COST OF CURB OR CURB AND GUTTER REMOVAL AND REPLACEMENT.

⑤ THE COST OF HMA SURFACE REMOVAL IN THE EXISTING GUTTER FLAG SHALL BE INCLUDED IN THE COST OF THE CURB AND GUTTER REMOVAL AND REPLACEMENT.

⑥ THE REMOVAL AND REPLACEMENT OF THE EXISTING CURB OR CURB AND GUTTER SHALL BE DONE IN ACCORDANCE WITH THE APPLICABLE PORTIONS OF SECTION 440 AND 606 OF THE STANDARD SPECIFICATIONS.

⑦ THE LOCATIONS OF REMOVAL AND REPLACEMENT OF EXISTING CURB OR CURB AND GUTTER SHALL BE DETERMINED BY THE RESIDENT ENGINEER AT THE TIME OF CONSTRUCTION.

UNSUITABLE SUB-BASE MATERIAL TO BE REMOVED, IF DIRECTED BY THE ENGINEER, SHALL BE REPLACED WITH EITHER SUB-BASE GRANULAR MATERIAL, TYPE B OR ADDITIONAL THICKNESS OF CONCRETE.

REMOVAL AND REPLACEMENT 4 (100) OR LESS IS INCLUDED IN THE COST OF CURB OR CURB AND GUTTER REMOVAL AND REPLACEMENT.

REMOVAL AND REPLACEMENT IN EXCESS OF 4 (100) WILL BE PAID FOR IN ACCORDANCE WITH ARTICLE 109.04 OF THE STANDARD SPECIFICATIONS.

PROPOSED #6 (20) EPOXY COATED TIE BARS 24 (600) LONG AT 24 (600) CENTERS WILL NOT BE PAID FOR SEPARATELY. DELETE EPOXY COATED TIE BARS IF EXISTING TIE BARS ARE USUABLE AS DETERMINED BY THE ENGINEER. (SEE NOTE ③).

**BASIS OF PAYMENT:**

THIS WORK WILL BE PAID FOR AT THE CONTRACT UNIT PRICE PER FOOT (METER) FOR "CURB REMOVAL AND REPLACEMENT" OR "COMBINATION CONCRETE CURB AND GUTTER REMOVAL AND REPLACEMENT".

ALL DIMENSIONS ARE IN INCHES (MILLIMETERS) UNLESS OTHERWISE SHOWN.

REVISIONS	
NAME	DATE
A. HOUSEH	03/11/94
R. SHAH	02/24/95
R. SHAH	03/02/95
R. SHAH	08/19/96
R. SHAH	09/12/96
R. SHAH	09/19/96
R. SHAH	10/03/96
A. ABBAS	03/21/97
M. GOMEZ	01/22/01
R. BORO	01/01/07

ILLINOIS DEPARTMENT OF TRANSPORTATION

**CURB OR CURB AND GUTTER REMOVAL AND REPLACEMENT**

SCALE: VERT. NONE  
HORIZ. NONE  
PLOT DATE: 12/21/2006

DRAWN BY  
CHECKED BY  
BD600-06 (BD-24)

REVISION DATE: 01/01/07

**CURB OR CURB AND GUTTER REMOVAL AND REPLACEMENT**

CONTRACT NO.				
F.A.U. RTE.	SECTION	COUNTY	TOTAL SHEETS	SHEET NO.
372	3091 RS-4	COOK	27	20
STA.		TO STA.		
FED. ROAD DIST. NO. 1		ILLINOIS FED. AID PROJECT		

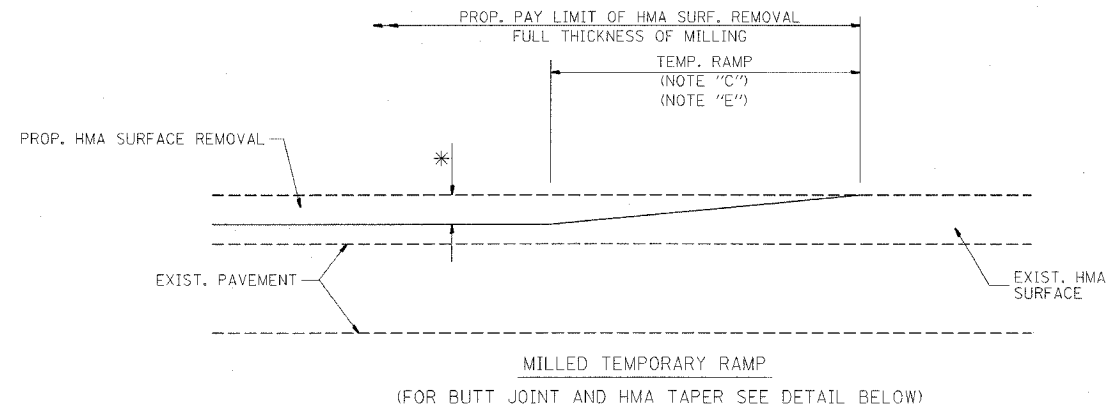

OPTION 1

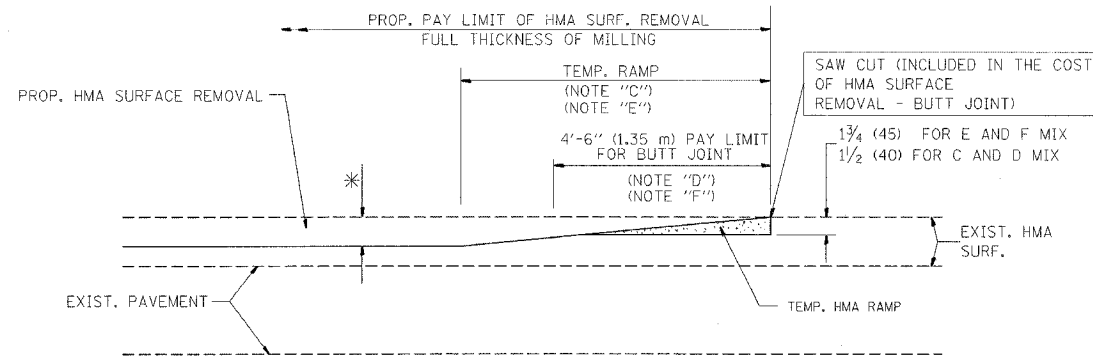

OPTION 2  
TYPICAL TEMPORARY RAMP

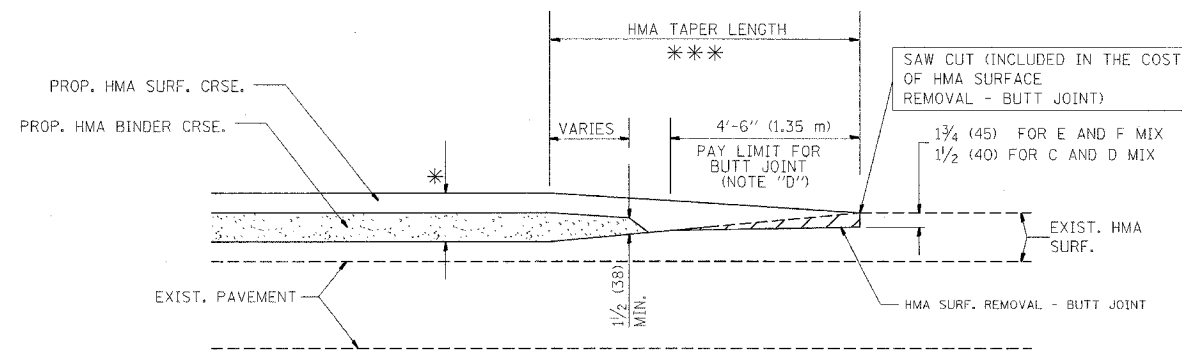

TYPICAL BUTT JOINT AND HMA TAPER  
FOR MILLING AND RESURFACING

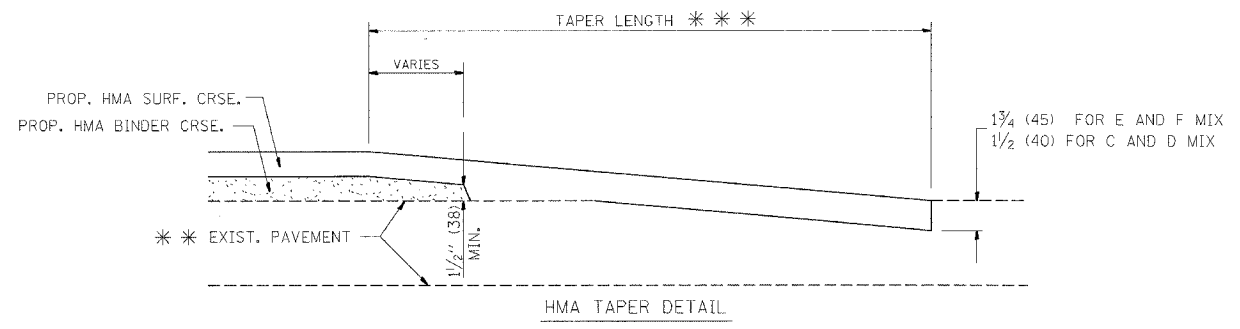
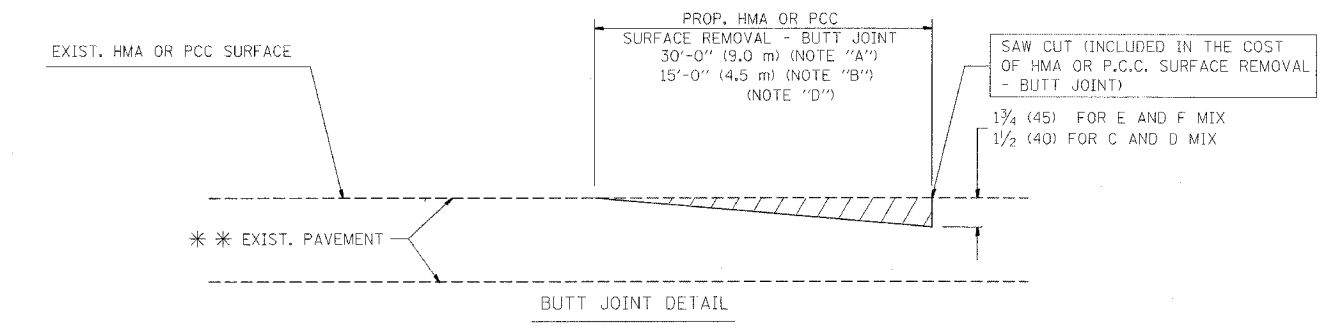

TYPICAL BUTT JOINT AND HMA TAPER  
FOR RESURFACING ONLY

\*\* PC CONCRETE, HMA OR HMA RESURFACED PAVEMENT.

NOTES

- A: MAINLINE ROADWAYS AND MAJOR SIDE ROADS.
  - B: MINOR SIDE ROADS.
  - C: THE TEMP. RAMP SHALL BE CONSTRUCTED IMMEDIATELY UPON REMOVAL OF THE EXISTING HMA SURFACE.
  - D: THE BUTT JOINT SHALL BE CONSTRUCTED IMMEDIATELY PRIOR TO PLACING THE PROPOSED HMA COURSES.
  - E: TAPER THE TEMP. RAMP AT A RATE OF 3'-0" (900 mm) PER 1 INCH (25 mm) OF MILLING THICKNESS.
  - F: INSTALLATION AND REMOVAL OF THE 4'-6" (1.35 m) TEMP. RAMP IS INCLUDED IN COST OF HMA SURFACE REMOVAL - BUTT JOINT
  - G: SEE ARTICLE 406.08 AND 406.14 OF THE STANDARD SPECIFICATIONS FOR "HMA AND/OR PCC SURFACE REMOVAL, BUTT JOINT".
- \* SEE TYPICAL SECTIONS FOR MILLING THICKNESS.
- \*\* 20'-0" (6.1 m) PER 1 (25) RESURFACING (NOTE "A")  
10'-0" (3.0 m) PER 1 (25) RESURFACING (NOTE "B")

ALL DIMENSIONS ARE IN INCHES (MILLIMETERS) UNLESS OTHERWISE SHOWN.

BASIS OF PAYMENT:

THE BUTT JOINT WILL BE PAID FOR AT THE CONTRACT UNIT PRICE PER SQUARE YARD (SQUARE METER) FOR "HOT-MIX ASPHALT SURFACE REMOVAL - BUTT JOINT" OR FOR "PORTLAND CEMENT CONCRETE SURFACE REMOVAL - BUTT JOINT".

REVISIONS	
NAME	DATE
M. DE YONG	6-13-90
M. DE YONG	7-3-90
M. DE YONG	3-27-92
R. SHAH	09/09/94
R. SHAH	10/26/94
A. ABBAS	03/21/97
M. GOMEZ	04/06/01
R. BORO	01/01/07

ILLINOIS DEPARTMENT OF TRANSPORTATION

BUTT JOINT AND  
HMA TAPER  
DETAILS

SCALE: VERT. NONE  
HORIZ. NONE  
PLOT DATE: 12/21/2006

DRAWN BY  
CHECKED BY

BD400-05 (VI-BD32)  
REVISION DATE: 01/01/07

PLOT DATE = 12/21/2006  
FILE NAME = \\adistntf2\Users\gulloume\Fp\Desktop\bd32.dgn  
PLOT SCALE = 48,9999 / 1 IN.  
USER NAME = gulloume\FP

F.A.P. RTE.	SECTION	COUNTY	TOTAL SHEETS	SHEET NO.
372	3091 RS-4	COOK	27	21
STA.		TO STA.		
FED. ROAD DIST. NO.	ILLINOIS	FED. AID PROJECT		

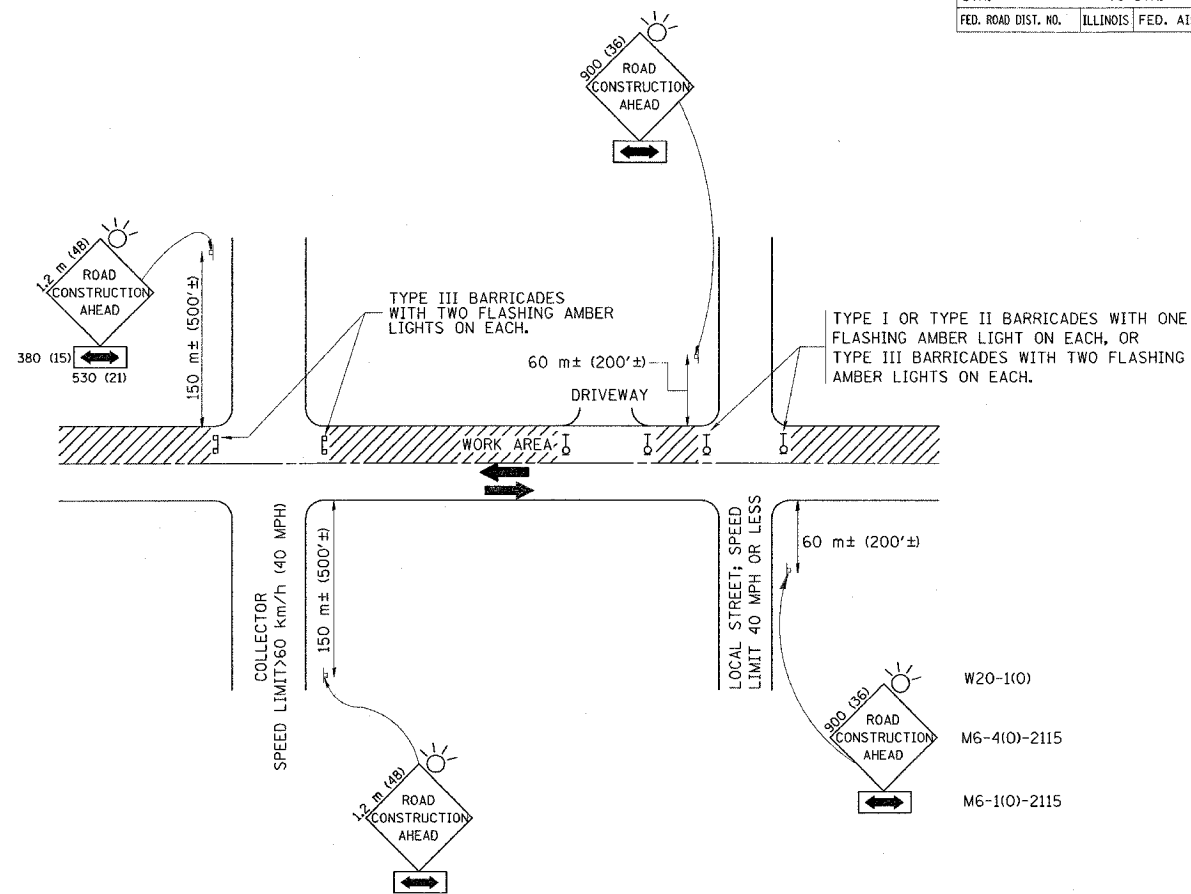

TRAFFIC CONTROL AND PROTECTION FOR SIDE ROADS, INTERSECTIONS, AND DRIVEWAYS

NOTES:

A. FOR NO LANE RESTRICTION ON THE SIDE ROAD OR DRIVEWAYS

1. SIDE ROAD WITH A SPEED LIMIT OF 60 km/h (40 MPH) OR LESS AS SHOWN ON THE DRAWING AND AS DIRECTED BY THE ENGINEER:

a) ONE ROAD CONSTRUCTION AHEAD SIGN 900x900 (36x36) WITH A FLASHER AND FLAG MOUNTED ON IT APPROXIMATELY 60 m (200') IN ADVANCE OF THE MAIN ROUTE.

b) THE CLOSED PORTION OF THE MAIN ROUTE SHALL BE PROTECTED BY BLOCKING WITH TYPE I, TYPE II OR TYPE III BARRICADES, 1/3 OF THE CROSS SECTION OF THE CLOSED PORTION.

2. SIDE ROAD WITH A SPEED LIMIT GREATER THAN 60 km/h (40 MPH) AS SHOWN ON THE DRAWING AND AS DIRECTED BY THE ENGINEER:

a) ONE ROAD CONSTRUCTION AHEAD SIGN 1.2 m x 1.2 m (48x48) WITH A FLASHER MOUNTED ON IT APPROXIMATELY 150 m (500') IN ADVANCE OF THE MAIN ROUTE.

b) THE CLOSED PORTION OF THE MAIN ROUTE SHALL BE PROTECTED BY BLOCKING WITH TYPE III BARRICADES, 1/2 OF THE CROSS SECTION OF THE CLOSED PORTION.

3. WHEN THE SIDE ROAD LIES BETWEEN THE BEGINNING OF THE MAINLINE SIGNING AND THE WORK ZONE, A SINGLE HEADED ARROW (M6-1) SHALL BE USED IN LIEU OF THE DOUBLE HEADED ARROW (M6-4).

B. FOR A LANE CLOSURE ON A SIDE ROAD OR DRIVEWAY:

USE APPLICABLE PORTIONS OF THE TYPICAL APPLICATION OF TRAFFIC CONTROL DEVICES (STD. 701501, STD. 701606 OR THE APPROPRIATE STANDARD). THE SPACING OF SIGNS AND BARRICADES SHALL BE ADJUSTED FOR FIELD CONDITIONS AS DIRECTED BY THE ENGINEER. THE DIRECTIONAL ARROW SHALL BE COVERED OR REMOVED WHEN NO LONGER CONSISTENT WITH THE SIDE ROAD LANE CLOSURE.

C. ADVANCE WARNING SIGNS ARE TO BE OMITTED ON DRIVEWAY UNLESS OTHERWISE NOTED.

D. THE TRAFFIC CONTROL AND PROTECTION FOR SIDE ROADS, INTERSECTIONS, AND DRIVEWAYS SHALL BE INCIDENTAL TO THE COST OF SPECIFIED TRAFFIC CONTROL STANDARDS OR ITEMS.

REVISIONS	
NAME	DATE
LHA	6/89
T. RAMMACHER	09/08/94
J. OBERLE	10/18/95
A. HOUSEH	03/06/96
A. HOUSEH	10/15/96
T. RAMMACHER	01/06/00

ILLINOIS DEPARTMENT OF TRANSPORTATION  
 TRAFFIC CONTROL AND PROTECTION  
 FOR  
 SIDE ROADS, INTERSECTIONS, AND  
 DRIVEWAYS

SCALE:  
 DATE: 12/21/2006

DRAWN BY  
 CHECKED BY

TC-10

REVISION DATE: 01/06/00

F.A.P. RTE.	SECTION	COUNTY	TOTAL SHEETS	SHEET NO.
370	3091 RS-4	COOK	27	22
STA.		TO STA.		
FED. ROAD DIST. NO.	ILLINOIS	FED. AID PROJECT		

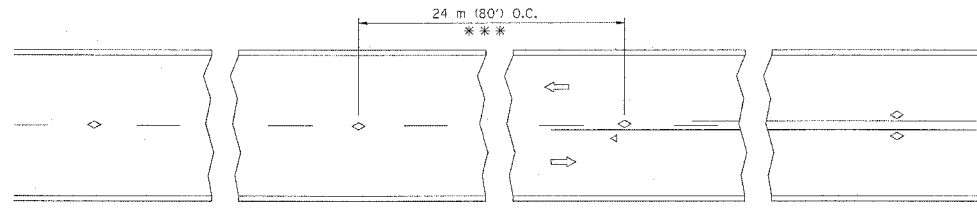

\*\*\* REDUCE TO 12 m (40') O.C. ON CURVES WITH POSTED OR ADVISORY SPEED 70 km/h (45 M.P.H.) OR LESS.

TWO-LANE/TWO-WAY

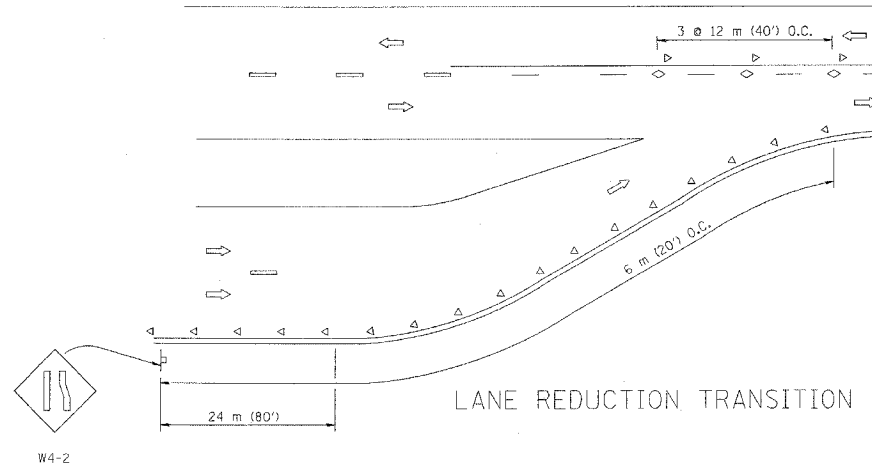

LANE REDUCTION TRANSITION

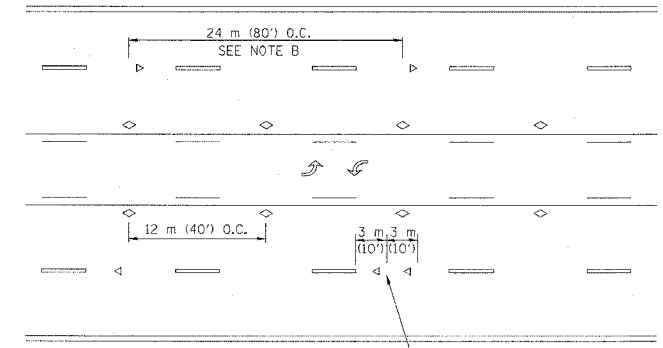

TWO-WAY LEFT TURN

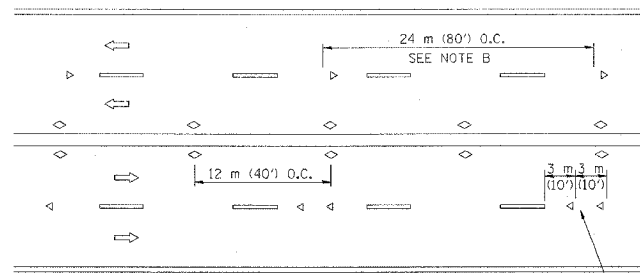

MULTI-LANE/UNDIVIDED

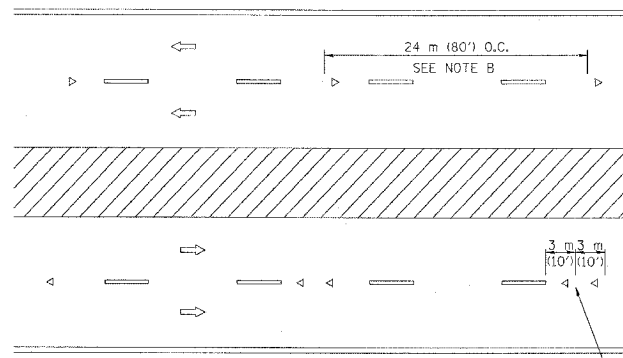

MULTI-LANE/DIVIDED

GENERAL NOTES

1. MARKERS USED WITH DASHED LINES SHALL BE CENTERED IN THE GAP BETWEEN SEGMENTS.
2. MARKERS USED ADJACENT TO SOLID LINES SHALL BE OFFSET 50 TO 75 (2 TO 3') TOWARD TRAFFIC AS SHOWN.
3. MARKERS THROUGH TANGENTS LESS THAN 150 m (500') IN LENGTH BETWEEN CURVES SHALL BE INSTALLED AT THE LESSER OF THE TWO CURVE SPACINGS.

SYMBOLS

- YELLOW STRIPE
- WHITE STRIPE
- ◁ ONE-WAY AMBER MARKER
- ◁ ONE-WAY CRYSTAL MARKER (W/O)
- ◇ TWO-WAY AMBER MARKER

LANE MARKER NOTES

- A. USE DOUBLE LANE LINE MARKERS SPACED AS SHOWN.
- B. REDUCE TO 12 m (40') O.C. ON CURVES WHERE ADVISORY SPEEDS ARE 20 km/h (10 M.P.H.) LOWER THAN POSTED SPEEDS.

DESIGN NOTES

1. DOUBLE LANE LINE MARKERS SHALL BE USED UNLESS SPECIFIED OTHERWISE.
2. EXCEPT AS SHOWN ON THE LANE REDUCTION TRANSITION AND FREEWAY EXIT RAMP DETAIL, MARKERS ARE NOT TO BE SPECIFIED ON RIGHT EDGE LINES.
3. THE EXACT MARKER LIMITS, SPACING, AND COLOR SHOULD BE INCLUDED IN THE PLANS.
4. MARKERS SHOULD NOT BE USED ALONGSIDE CURBS EXCEPT FOR EXTREMELY SHORT SECTIONS OF CURBS WHERE NOT MORE THAN TWO MARKERS WOULD BE INVOLVED.

All dimensions are in millimeters (inches) unless otherwise shown.

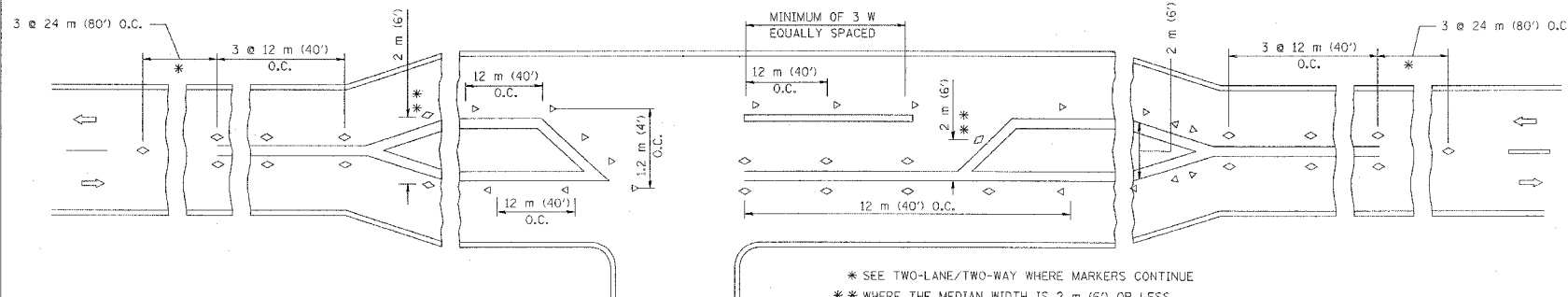

LEFT TURN

\* SEE TWO-LANE/TWO-WAY WHERE MARKERS CONTINUE  
 \*\* WHERE THE MEDIAN WIDTH IS 2 m (6') OR LESS USE TWO-WAY MARKERS.

PLOT DATE = 12/21/2006  
 FILE NAME = \\nas101r2\users\gull\awm\p\Drawings\TC-11.dgn  
 PLOT SCALE = 50,000 / IN.  
 USER NAME = gull\awm\p

REVISIONS	
NAME	DATE
T. RAMMACHER	09-19-94
T. RAMMACHER	03-12-99
T. RAMMACHER	01-06-00

ILLINOIS DEPARTMENT OF TRANSPORTATION  
 TYPICAL APPLICATIONS  
 RAISED REFLECTIVE PAVEMENT  
 MARKERS (SNOW-PLOW RESISTANT)

SCALE: NONE  
 DATE: 12/21/2006

DRAWN BY CADD  
 CHECKED BY TC-11

REVISION DATE: 01/06/00

F.A.P. RTE.	SECTION	COUNTY	TOTAL SHEETS	SHEET NO.
372	3091 RS-4	COOK	27	23
STA.		TO STA.		
FED. ROAD DIST. NO.		ILLINOIS FED. AID PROJECT		

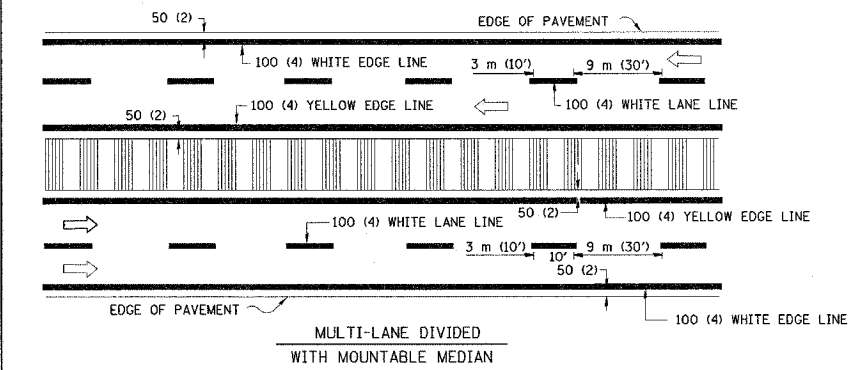
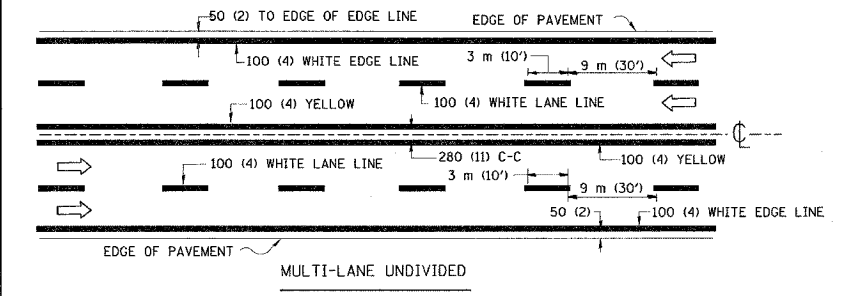
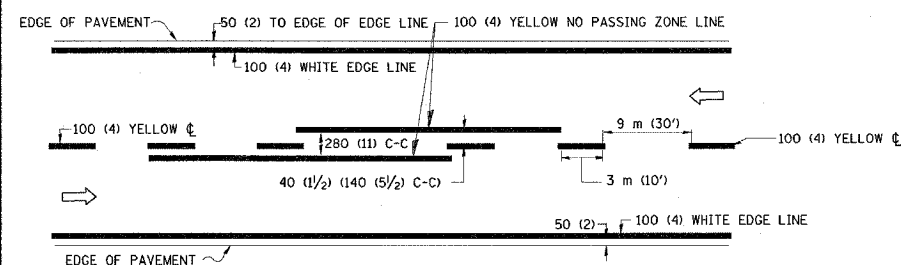

NOTE: MEDIANS WITH BARRIER CURBS DO NOT REQUIRE AN EDGE LINE

TYPICAL LANE AND EDGE LINE MARKING

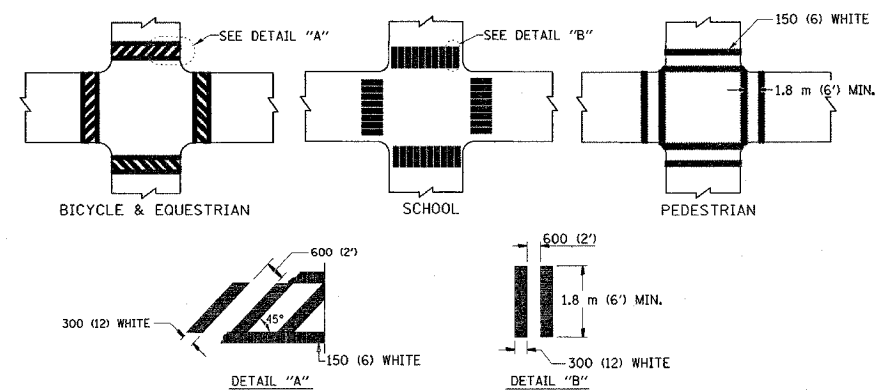

TYPICAL CROSSWALK MARKING

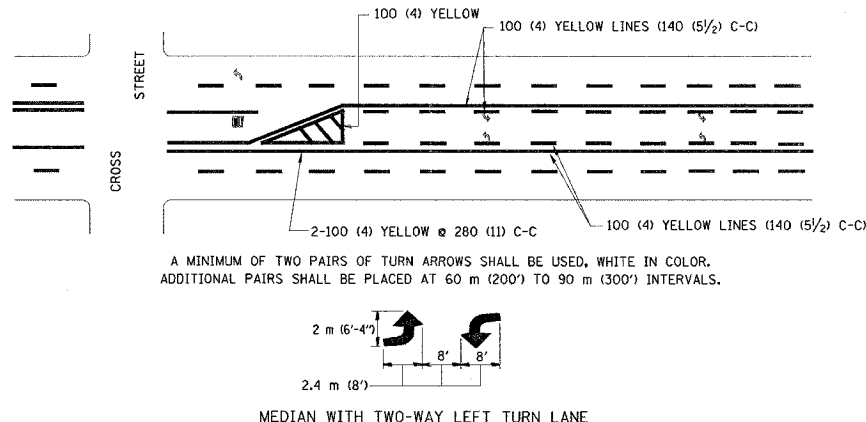
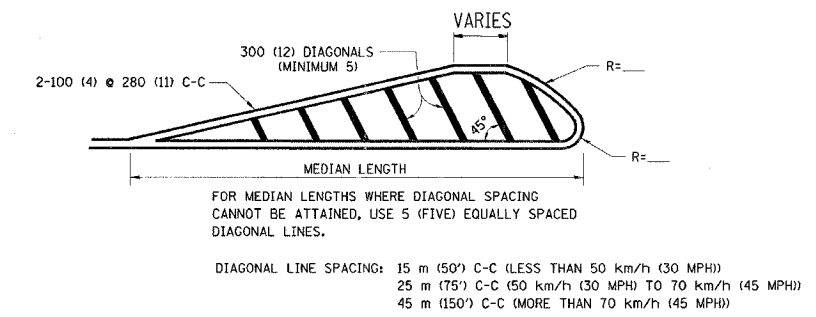
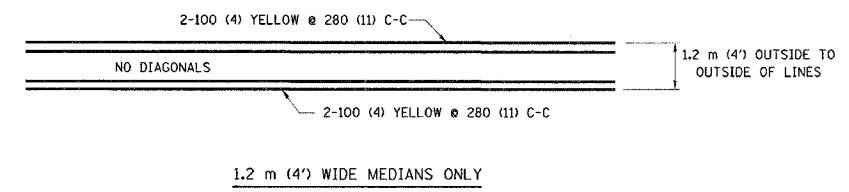

TYPICAL PAINTED MEDIAN MARKING

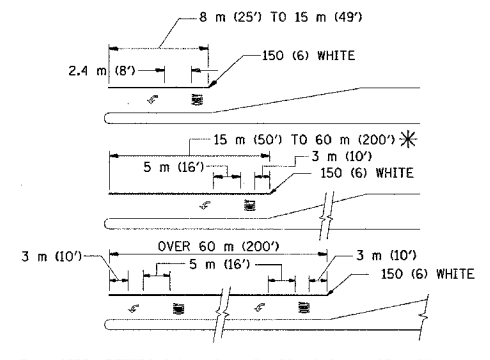

TYPICAL LEFT (OR RIGHT) TURN LANE MARKING

TYPICAL TURN LANE MARKING

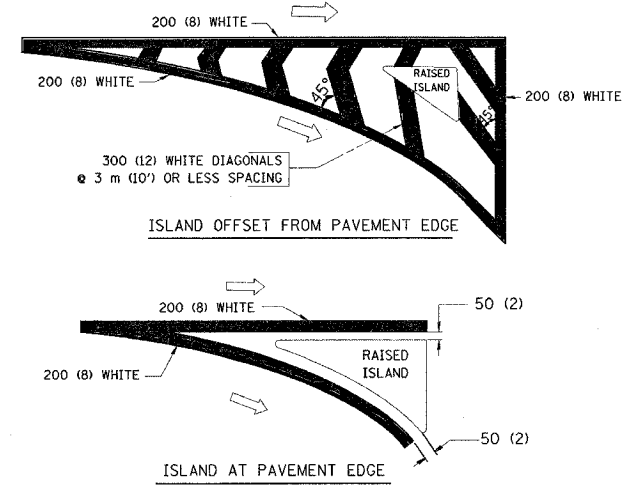

TYPICAL ISLAND MARKING

TYPE OF MARKING	WIDTH OF LINE	PATTERN	COLOR	SPACING / REMARKS
CENTERLINE ON 2 LANE PAVEMENT	100 (4)	SKIP-DASH	YELLOW	3 m (10') LINE WITH 9 m (30') SPACE
CENTERLINE ON MULTI-LANE UNDIVIDED PAVEMENT	2 @ 100 (4)	SOLID	YELLOW	280 (11) C-C
NO PASSING ZONE LINES: FOR ONE DIRECTION FOR BOTH DIRECTIONS	100 (4) 2 @ 100 (4)	SOLID SOLID	YELLOW YELLOW	140 (5 1/2) C-C FROM SKIP-DASH CENTERLINE 280 (11) C-C OMIT SKIP-DASH CENTERLINE BETWEEN
LANE LINES	100 (4) 125 (5) ON FREEWAYS	SKIP-DASH SKIP-DASH	WHITE WHITE	3 m (10') LINE WITH 9 m (30') SPACE
DOTTED LINES (EXTENSIONS OF CENTER, LANE OR TURN LANE MARKINGS)	SAME AS LINE BEING EXTENDED	SKIP-DASH	SAME AS LINE BEING EXTENDED	600 (2') LINE WITH 1.8 m (6') SPACE
EDGE LINES	100 (4)	SOLID	YELLOW-LEFT WHITE-RIGHT	OUTLINE MOUNTABLE MEDIANS IN YELLOW; EDGE LINES ARE NOT USED NEXT TO BARRIER CURB
TURN LANE MARKINGS	150 (6) LINE; FULL SIZE LETTERS & SYMBOLS (2.4 m (8'))	SOLID	WHITE	SEE TYPICAL TURN LANE MARKING DETAIL
TWO WAY LEFT TURN MARKING	2 @ 100 (4) EACH DIRECTION 2.4 m (8') LEFT ARROW	SKIP-DASH AND SOLID IN PAIRS	YELLOW WHITE	3 m (10') LINE WITH 9 m (30') SPACE FOR SKIP-DASH; 140 (5 1/2) C-C BETWEEN SOLID LINE AND SKIP-DASH LINE SEE TYPICAL TWO-WAY LEFT TURN MARKING DETAIL
CROSSWALK LINES (PEDESTRIAN) A. DIAGONALS (BIKE & EQUESTRIAN) B. LONGITUDINAL BARS (SCHOOL)	2 @ 150 (6) 300 (12) @ 45° 300 (12) @ 90°	SOLID SOLID SOLID	WHITE WHITE WHITE	NOT LESS THAN 1.8 m (6') APART 600 (2') APART 600 (2') APART SEE TYPICAL CROSSWALK MARKING DETAILS.
STOP LINES	600 (24)	SOLID	WHITE	PLACE 1.2 m (4') IN ADVANCE OF AND PARALLEL TO CROSSWALK, IF PRESENT. OTHERWISE, PLACE AT DESIRED STOPPING POINT. PARALLEL TO CROSSROAD CENTERLINE, WHERE POSSIBLE
PAINTED MEDIANS	2 @ 100 (4) WITH 300 (12) DIAGONALS @ 45° NO DIAGONALS USED FOR 1.2 m (4') WIDE MEDIANS	SOLID	YELLOW; TWO WAY TRAFFIC WHITE; ONE WAY TRAFFIC	280 (11) C-C FOR THE DOUBLE LINE SEE TYPICAL PAINTED MEDIAN MARKING.
GORE MARKING AND CHANNELIZING LINES	200 (8) WITH 300 (12) DIAGONALS @ 45°	SOLID	WHITE	DIAGONALS: 4.5 m (15') C-C (LESS THAN 50 km/h (30 MPH)) 6 m (20') C-C (50 km/h (30 MPH) TO 70 km/h (45 MPH)) 9 m (30') C-C (OVER 70 km/h (45 MPH))
RAILROAD CROSSING	600 (24) TRANSVERSE LINES; "RR" IS 1.8 m (6') LETTERS; 400 (16) LINE FOR "X"	SOLID	WHITE	SEE STATE STANDARD 780001 AREA OF: "R"=0.33m <sup>2</sup> (3.6 SQ. FT.) EACH "X"=5.0 m <sup>2</sup> (54.0 SQ. FT.)
SHOULDER DIAGONALS	300 (12) @ 45°	SOLID	WHITE - RIGHT YELLOW - LEFT	15 m (50') C-C (LESS THAN 50 km/h (30 MPH)) 25 m (75') C-C (50 km/h (30 MPH) TO 70 km/h (45 MPH)) 45 m (150') C-C (OVER 70 km/h (45 MPH))

FOR FURTHER DETAILS ON PAVEMENT MARKING REFER TO STANDARD SPECIFICATIONS FOR ROAD AND BRIDGE CONSTRUCTION AND STATE STANDARD 780001.

All dimensions are in millimeters (inches) unless otherwise shown.

REVISIONS		
NAME	DATE	
EVERS	03-19-90	
T. RAMMACHER	10-27-94	
ALEX HOUSEH	10-09-96	
ALEX HOUSEH	10-17-96	
T. RAMMACHER	01-06-00	

ILLINOIS DEPARTMENT OF TRANSPORTATION  
DISTRICT ONE  
TYPICAL PAVEMENT MARKINGS

SCALE: NONE  
DATE: 12/21/2006  
DRAWN BY CADD  
CHECKED BY

PLOT DATE = 12/21/2006  
FILE NAME = \\dasdrf22\user\gull\lumar\p\check\cop\10213.dgn  
PLOT SCALE = 0.8000 / IN.  
USER NAME = gulllumarfp



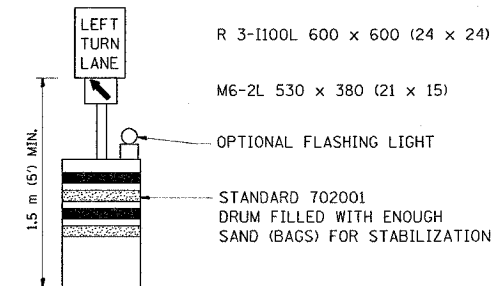
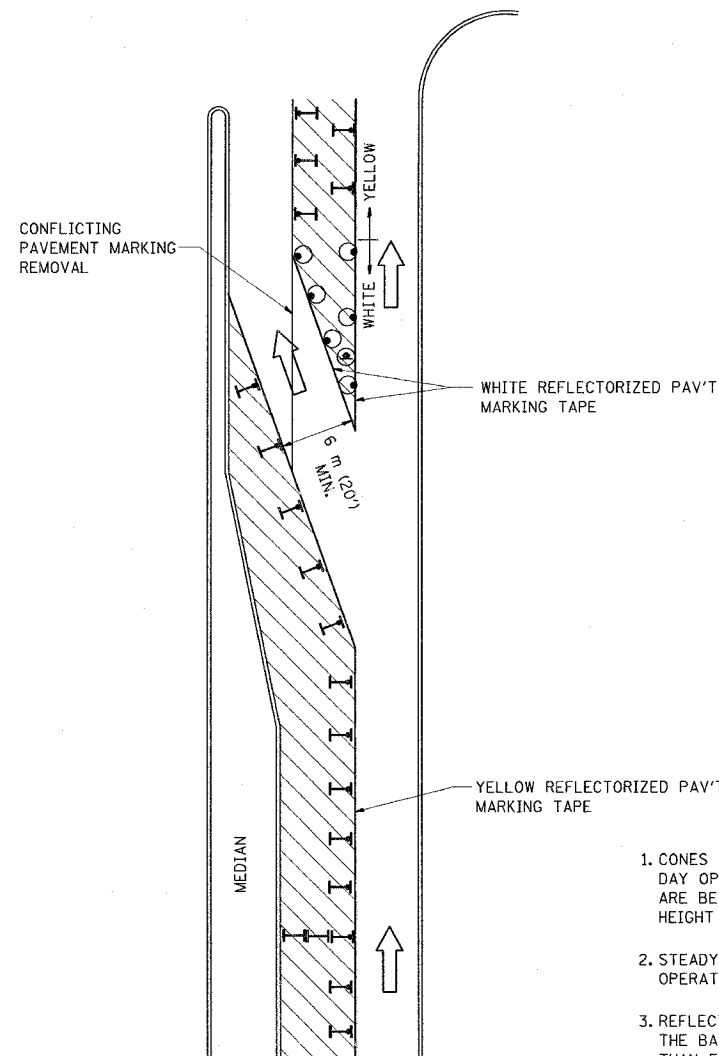



F.A.P. RTE.	SECTION	COUNTY	TOTAL SHEETS	SHEET NO.
372	3091 RS-4	COOK	27	24
STA.		TO STA.		
FED. ROAD DIST. NO.	ILLINOIS	FED. AID PROJECT		

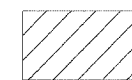

**GENERAL NOTES**

1. CONES MAY BE SUBSTITUTED FOR BARRICADES OR DRUMS AT HALF THE SPACING DURING DAY OPERATIONS. CONES SHALL BE A MINIMUM OF 710 (28) IN HEIGHT. WHEN CONES ARE BEING USED, THE "LEFT TURN LANE" SIGN MAY BE SKID MOUNTED AT A MINIMUM HEIGHT OF 1.5 m (5').
2. STEADY BURNING LIGHTS WILL NOT BE REQUIRED ON BARRICADES OR DRUMS FOR DAY OPERATIONS. ALL LIGHTS SHALL BE MONODIRECTIONAL.
3. REFLECTORIZED TEMPORARY PAVEMENT MARKING TAPE SHALL BE PLACED THROUGHOUT THE BARRICADED AREA OF EACH TURN BAY WHERE THE CLOSURE TIME IS GREATER THAN FOURTEEN DAYS.
4. THIS APPLICATION ALSO APPLIES WHEN WORK IS BEING PERFORMED IN THE RIGHT LANE(S) AND THE RIGHT TURN BAY IS TO REMAIN OPEN. UNDER THIS CONDITION, "RIGHT TURN LANE" R3-100 600 x 600 (24 x 24) AND M6-2R 530 x 380 (21 x 15) SHALL BE USED.
5. THESE CONTROLS SHALL SUPPLEMENT MAINLINE TRAFFIC CONTROL FOR LANE CLOSURES.
6. LONGITUDINAL DIMENSIONS MAY BE ADJUSTED TO FIT FIELD CONDITIONS.
7. FORM BT 725 IS REQUIRED.
8. TRAFFIC CONTROL AND PROTECTION AT TURN BAYS (TO REMAIN OPEN TO TRAFFIC) SHALL BE INCLUDED IN THE COST SPECIFIED TRAFFIC CONTROL STANDARDS OR ITEMS.

**LEGEND**

-  WORK AREA
-  LANE OPEN TO TRAFFIC
-  TYPE I OR II BARRICADE WITH STEADY BURN LIGHT
-  DRUM WITH STEADY BURN LIGHT
-  DRUM WITH SIGN (WITH OPTIONAL FLASHING LIGHT) SEE DETAIL
-  TYPE I OR II CHECK BARRICADE WITH FLASHING LIGHT

All dimensions are in millimeters (inches) unless otherwise shown.

REVISIONS	
NAME	DATE
T. RAMMACHER	09/08/94
A. HOUSEH	11/07/95
A. HOUSEH	10/12/96
T. RAMMACHER	01/06/00

ILLINOIS DEPARTMENT OF TRANSPORTATION  
**TRAFFIC CONTROL AND PROTECTION  
 AT TURN BAYS  
 (TO REMAIN OPEN TO TRAFFIC)**

SCALE: NONE  
 DATE: 12/21/2006

DRAWN BY  
 CHECKED BY LHA  
 TC-14  
 REVISION DATE: 01/06/00



F.A.P. RTE.	SECTION	COUNTY	TOTAL SHEETS	SHEET NO.
372	3091 RS-4	COOK	27	25
STA.		TO STA.		
FED. ROAD DIST. NO.		ILLINOIS FED. AID PROJECT		

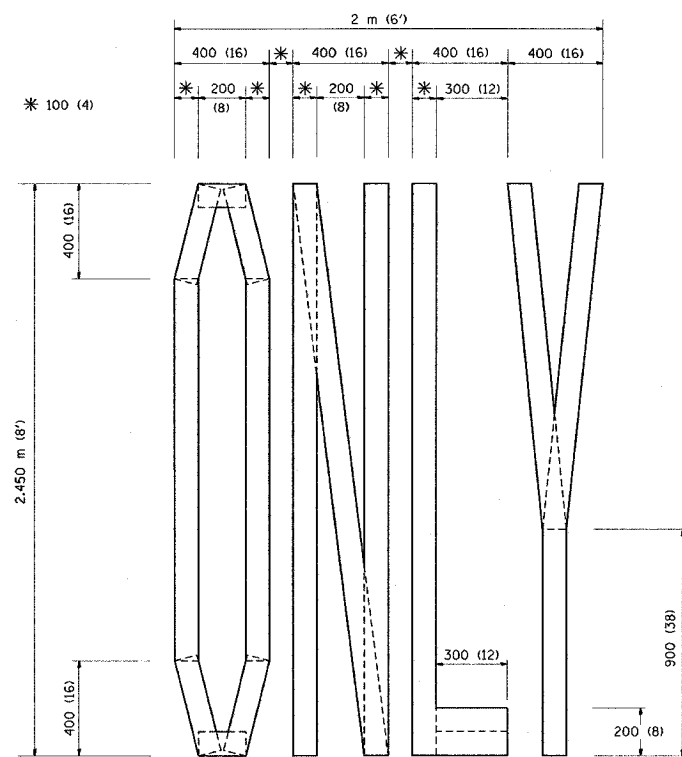

QUANTITY  
 100 (4) LINE = 19.7 m (64.1 ft.)  
 1.97 sq. m (21.1 sq. ft.)

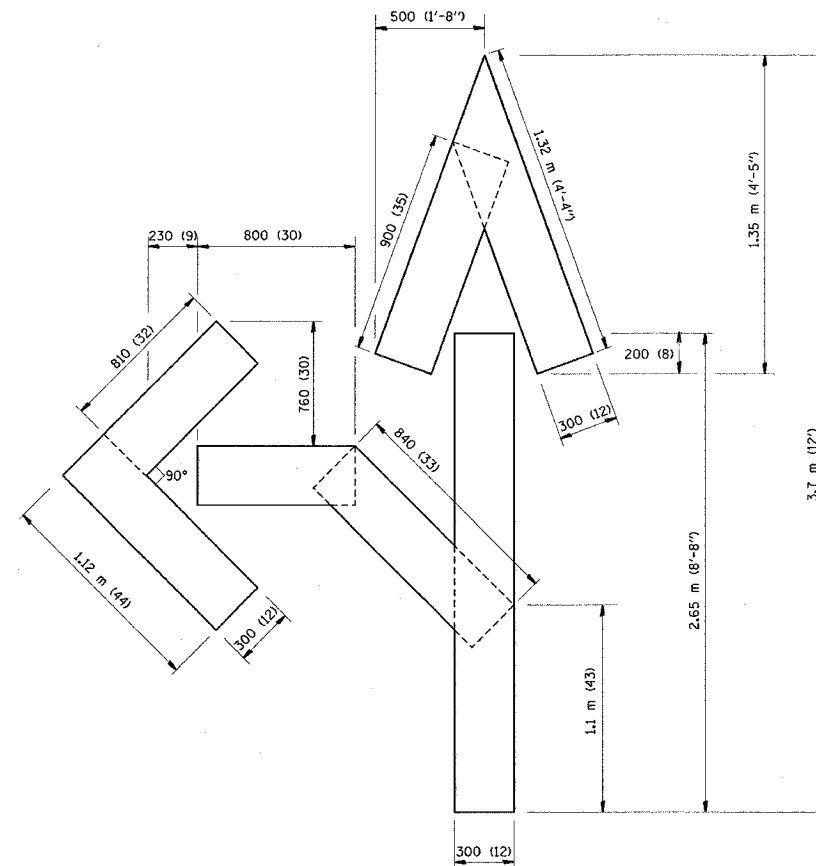

QUANTITY  
 100 (4) LINE = 25.3 m (82.5 ft.)  
 2.53 sq. m (27.5 sq. ft.)

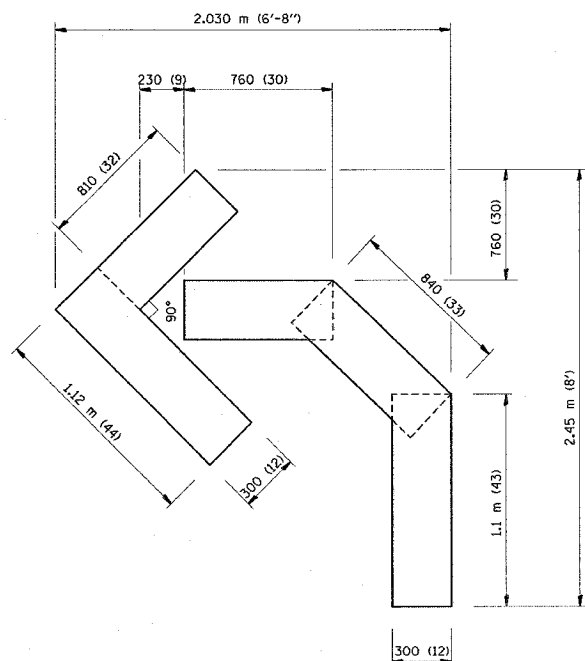

QUANTITY  
 100 (4) LINE = 13.9 m (45.5 ft.)  
 1.39 sq. m (15.2 sq. ft.)

All dimensions are in millimeters (Inches) unless otherwise shown.

REVISIONS	
NAME	DATE
T. RAMMACHER	09/18/94
J. OBERLE	06/01/96
T. RAMMACHER	06/05/96
T. RAMMACHER	11/04/97
T. RAMMACHER	03/02/98
E. GOMEZ	08/28/00

ILLINOIS DEPARTMENT OF TRANSPORTATION

PAVEMENT MARKING  
 LETTERS AND SYMBOLS  
 FOR TRAFFIC STAGING

SCALE: NONE  
 DATE: 12/21/2006

DRAWN BY CADD  
 CHECKED BY

TC-16

REVISION DATE: 08/28/00

F.A.P. RTE.	SECTION	COUNTY	TOTAL SHEETS	SHEET NO.
372	3091 RS-4	COOK	27	26
STA.		TO STA.		
FED. ROAD DIST. NO.	ILLINOIS	FED. AID PROJECT		

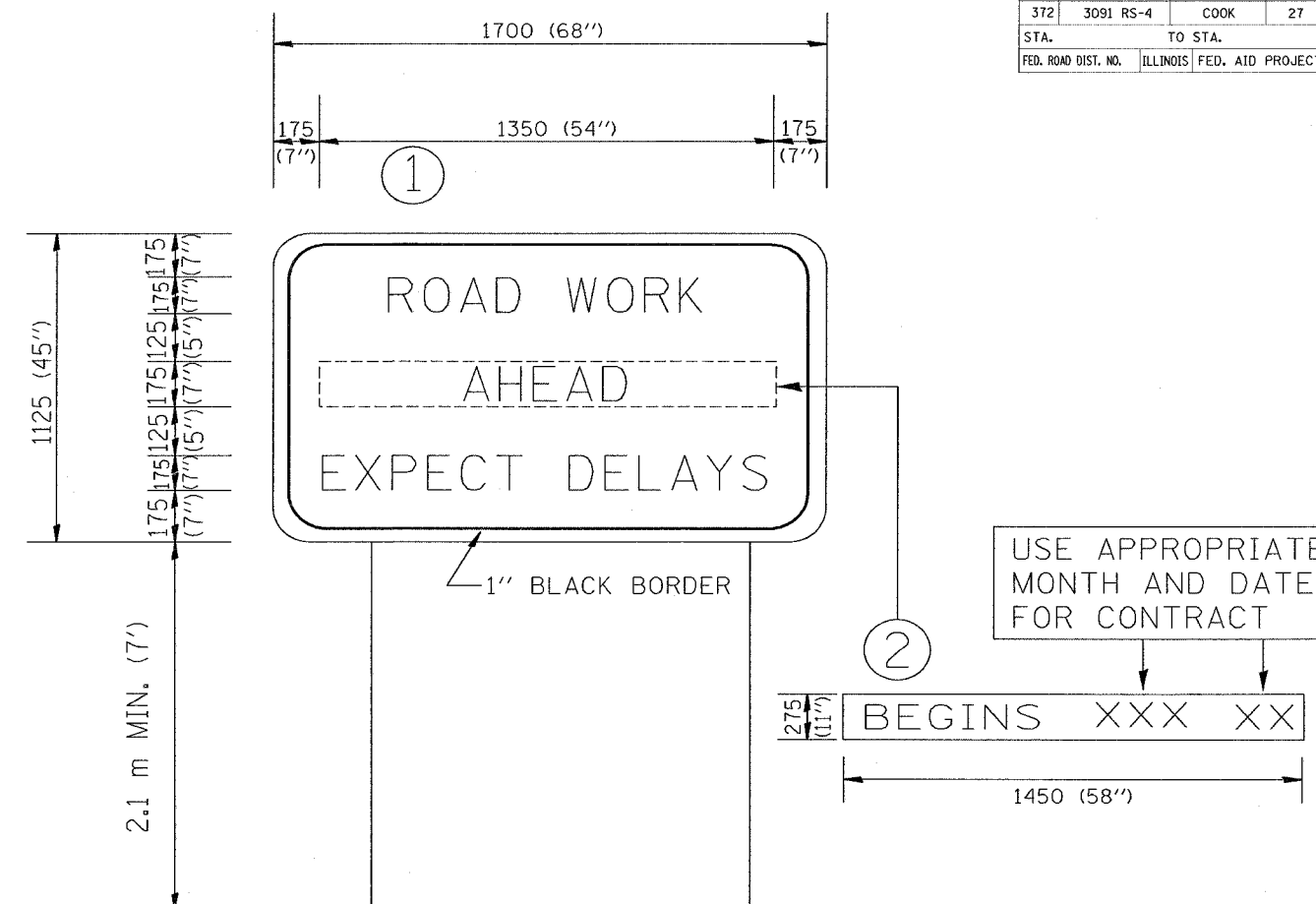

NOTES:

1. USE BLACK LETTERING ON ORANGE BACKGROUND.
2. ERECT SIGNS IN ADVANCE OF THE LOCATION FOR THE "ROAD CONSTRUCTION AHEAD" SIGN AT LOCATIONS AS DIRECTED BY THE ENGINEER.
3. ERECT SIGN ① WITH INSTALLED PANEL ② ONE WEEK PRIOR TO THE START OF CONSTRUCTION.
4. REMOVE PANEL ② SOON AFTER THE START OF CONSTRUCTION.
5. SEE SPECIAL PROVISION FOR "TEMPORARY INFORMATION SIGNING" FOR ADDITIONAL INFORMATION.
6. ONE SIGN ASSEMBLY EQUALS 2.3 SQ. M. (25.70 SQ. FT.)

ALL DIMENSIONS ARE IN MILLIMETERS (INCHES) UNLESS OTHERWISE SHOWN.

REVISIONS	
NAME	DATE
R. MIRS	9-15-97
R. MIRS	12-11-97
T. RAMMACHER	2-2-99

ILLINOIS DEPARTMENT OF TRANSPORTATION  
 TEMPORARY INFORMATION SIGNING

SCALE:  
 DATE: 12/21/2006

DRAWN BY DESIGN  
 CHECKED BY

TC22  
 REVISION DATE: 02/02/99

F.A.P. RTE.	SECTION	COUNTY	TOTAL SHEETS	SHEET NO.
372	3091 RS-4	COOK	27	27
STA.		TO STA.		
FED. ROAD DIST. NO.		ILLINOIS FED. AID PROJECT		

**LOOPS NEXT TO SHOULDERS**

PROVIDE A PAVEMENT REPLACEMENT NOTE WHICH SHOULD EQUAL 3' (900 mm) X WIDTH OF PAVED SHOULDER.

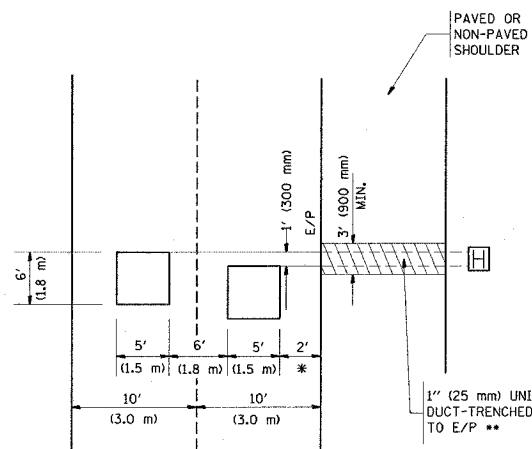

\* = (600 mm)

\*\* UNIT DUCT IS TO BE SHOWN ON PLAN SHEETS BUT SHALL NOT BE INCLUDED IN THE PAY ITEMS.

**LEFT TURN LANES WITH MEDIANS  
VOLUME DENSITY ("FAR OUT" DETECTION)  
ON SAME APPROACH  
(PROTECTED / PERMITTED LEFT TURN PHASING)**

HANDHOLE LOCATION MAY VARY DEPENDING ON GEOMETRICS AND DESIGN OF TRAFFIC SIGNALS. HEAVY-DUTY HANDHOLES TO BE USED WHEN THE MEDIAN IS MOUNTABLE. REFER TO STANDARD B14001 TO ENSURE THAT HANDHOLE FITS IN MEDIAN.

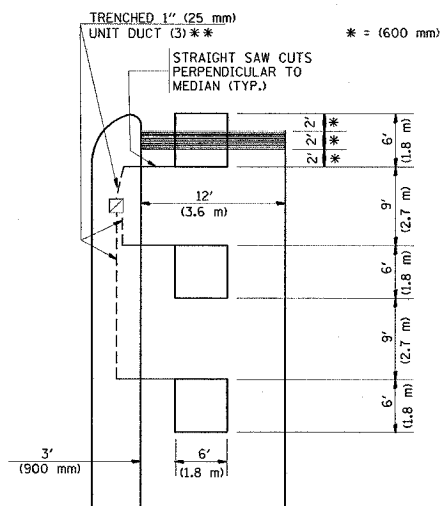

\*\* UNIT DUCT IS TO BE SHOWN ON PLAN SHEETS BUT SHALL NOT BE INCLUDED IN THE PAY ITEMS.

NOTE: DUAL LEFT TURNS NOT SHOWN REFER TO PLAN SHEET FOR DETECTOR LOOP REPLACEMENT

**LEFT TURN LANES WITHOUT MEDIANS  
VOLUME DENSITY ("FAR OUT" DETECTION)  
ON SAME APPROACH  
(PROTECTED / PERMITTED LEFT TURN PHASING)**

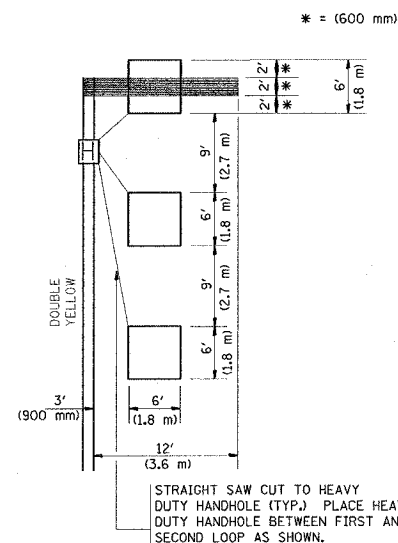

NOTE: DUAL LEFT TURNS NOT SHOWN REFER TO PLAN SHEET FOR DETECTOR LOOP REPLACEMENT

**ARTERIAL-VOLUME DENSITY ("FAR OUT" DETECTION)  
CROSS STREET-VOLUME DENSITY ("FAR OUT" DETECTION)**

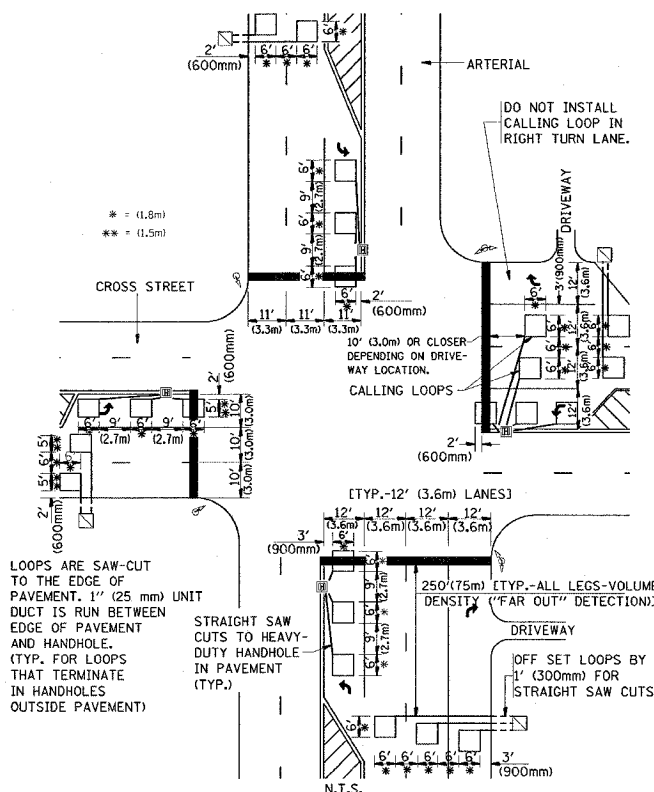

DETAIL 1  
N.T.S.

**ARTERIAL-VOLUME DENSITY ("FAR OUT" DETECTION)  
CROSS STREET-NON VOLUME DENSITY ("UPTIGHT" PRESENCE DETECTION)**

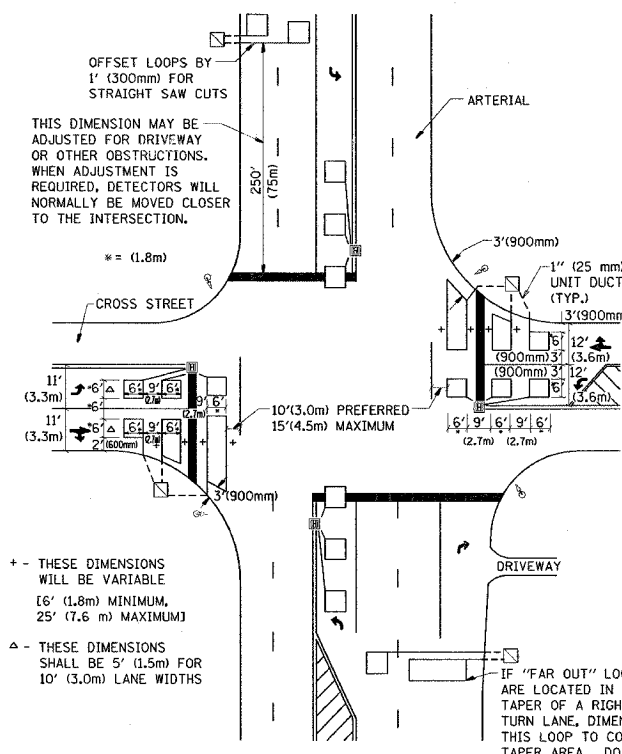

DETAIL 2  
N.T.S.

**NOTES:**

**VEHICLES LOOP DETECTORS**

- \* ALL LEAD IN CABLE SHALL BE TWO CONDUCTOR NO. 14 TWISTED, SHIELDED.
- \* EACH DETECTOR LOOP SHALL HAVE ITS OWN SAW CUT FROM THE LOOP TO THE EDGE OF PAVEMENT OR TO A HANDHOLE IN THE PAVEMENT.
- \* EACH DETECTOR LOOP SHALL HAVE ITS OWN ONE INCH (25 mm) UNIT DUCT BETWEEN THE EDGE OF PAVEMENT AND THE FIRST HANDHOLE OR JUNCTION BOX. EACH UNIT DUCT RUN SHALL BE SHOWN ON THE PLANS BY THE DESIGNER, BUT SHALL NOT BE PAID FOR SEPARATELY. THIS ITEM IS INCIDENTAL TO THE PAY ITEM FOR DETECTOR LOOPS.
- \* ONE DIMENSION OF ALL DETECTOR LOOPS SHALL BE SIX FEET (1.8 m)
- \* EACH LANE OF NON-LOCKING, PRESENCE DETECTION AND EACH LANE OF A DOUBLE LEFT TURN LANE REQUIRES A SEPARATE INDUCTIVE LOOP DETECTOR AND LEAD IN CABLE.
- \* WHEN NON-LOCKING, PRESENCE DETECTION IS USED, MORE THAN ONE LOOP PER LANE IS REQUIRED BEHIND THE STOP BAR (i.e. 1-1/2, 1-3/4, 2).
- \* WHEN SYSTEM LOOPS ARE REQUIRED ON AN APPROACH OF AN INTERSECTION, THE LOOPS USED FOR VOLUME DENSITY AND INTERSECTION TIMING SHALL ALSO BE USED AS SYSTEM DETECTORS. EACH ONE OF THESE TYPE OF LOOPS REQUIRES A SEPARATE TWO CONDUCTOR NO. 14 TWISTED SHIELDED CABLE AND A SEPARATE INDUCTIVE LOOP DETECTOR WHEN NEW CONTROLLERS ARE UTILIZED. THE DESIGNER SHALL LABEL THESE TYPES OF LOOPS AS "INTERSECTION AND SAMPLING (SYSTEM) DETECTORS" ON THE SIGNAL LAYOUT, THE INTERCONNECT PLAN AND THE SYSTEM CABLE PLAN. WHEN AN EXISTING CONTROLLER IS UTILIZED FOR THIS TYPE OF DETECTION, THE PAY ITEM "INDUCTIVE LOOP DETECTOR WITH SYSTEM OUTPUT" SHOULD BE USED.

**PLACEMENT OF DETECTORS**

THE FOLLOWING FIGURES REPRESENT THE MOST COMMON DETECTOR LOOP LOCATIONS AND SIZES. ADJUSTMENTS WILL BE NECESSARY FOR SPECIFIC GEOMETRIC CONSIDERATIONS.

LOCATIONS AND DEMENSIONS OF DETECTOR LOOPS ARE REQUIRED ON ALL SIGNAL LAYOUT PLAN SHEETS.

"FAR OUT" DETECTION REFERS TO LOCKING, PRESENCE TYPE DETECTION LOCATED IN THRU LANES, RIGHT TURN LANES, AND RIGHT TURN LANE TAPER AREAS (IF APPLICABLE), USUALLY 250' (75 m) IN ADVANCE OF STOP BARS. "UPTIGHT" DETECTION REFERS TO NON-LOCKING PRESENCE TYPE DETECTION LOCATED IN ALL LANES AND 10'-15' (3.0 m-4.5 m) BEHIND THE CROSSING STREET'S EDGE OF PAVEMENT EXTENDED.

**NOTE:**

ALL DETAILS AND NOTES SHOWN ARE FROM THE I.D.O.T. DISTRICT 1 TRAFFIC SIGNAL DESIGN GUIDELINES DATED JANUARY 1995

THIS DRAWING HAS BEEN PREPARED TO ASSIST THE RESIDENT ENGINEER FOR ALL ROADWAY RESURFACING OR S.M.A.R.T. PROJECTS WHERE THE DIMENSIONS ARE NOT SHOWN ON THE PLANS AND THE FINAL LOCATIONS FOR CROSSWALKS OR STOP BARS ARE NOT DETERMINED.

REVISIONS	
NAME	DATE

ILLINOIS DEPARTMENT OF TRANSPORTATION  
DISTRICT 1  
DETECTOR LOOP  
INSTALLATION DETAILS  
FOR ROADWAY RESURFACING

SCALE: NONE  
DATE: 12/21/2006

DESIGNED BY  
DRAWN BY CADD  
CHECKED BY R.K.F.  
TSOT  
REVISION DATE: