

*(102 BR-1, 102 BR-2, 102 BR-3)D
Contract # 64C93

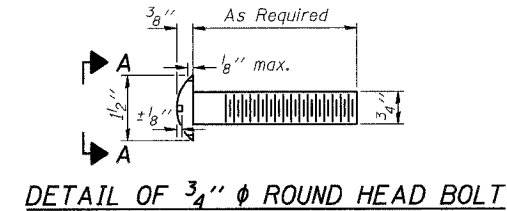

DETAIL OF 3/4" ϕ ROUND HEAD BOLT

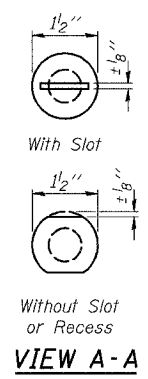

VIEW A-A

4-3/4" ϕ x 6" Round Head Bolts (With slot or approved recess in head) with locknut & flat washer. 7/8" ϕ holes in hollow structural section may be drilled in the field.

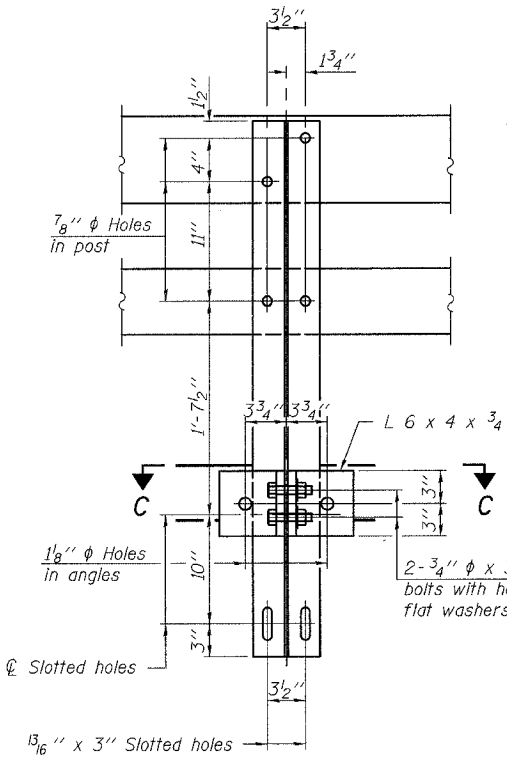

SECTION B-B

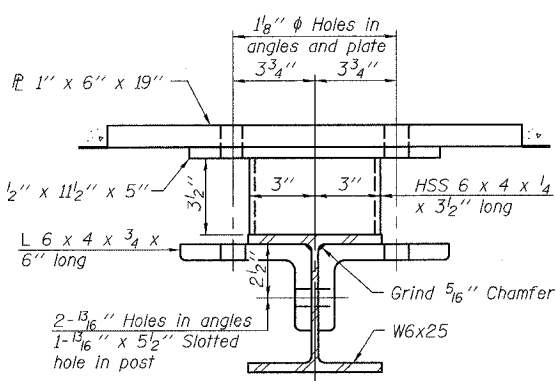

SECTION C-C

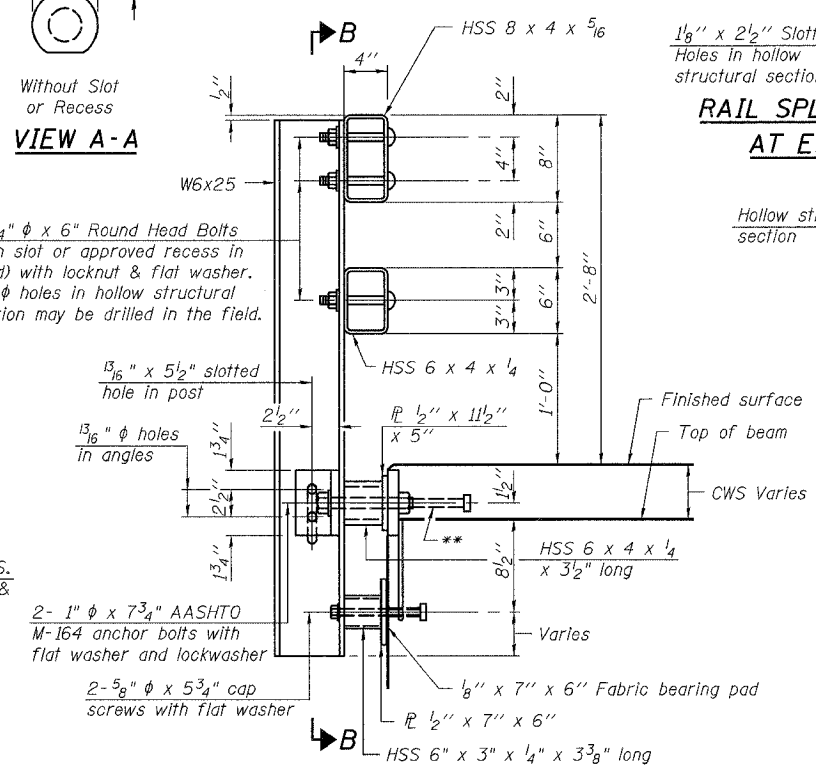

SECTION AT RAIL POST

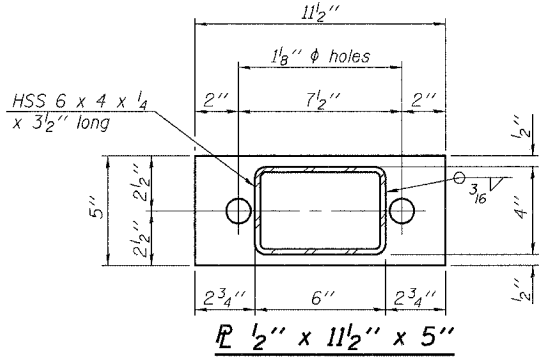

PLAN-BOTT. SPLICE TYPICAL

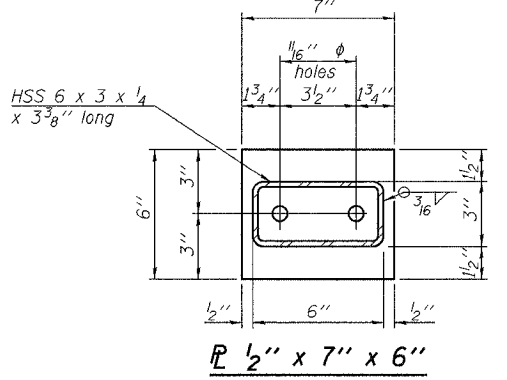

ANCHOR DEVICE

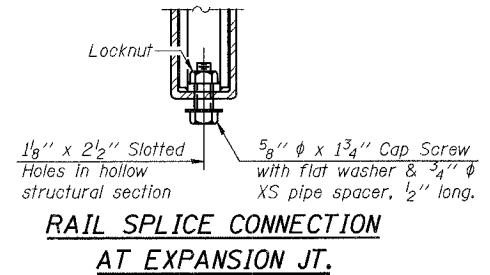

RAIL SPLICE CONNECTION AT EXPANSION JT.

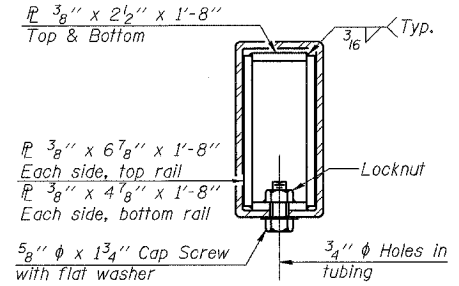

SECTION AT RAIL SPLICE

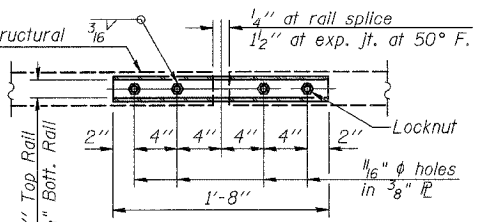

VIEW D-D

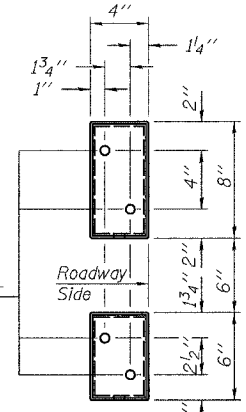

VIEW E-E

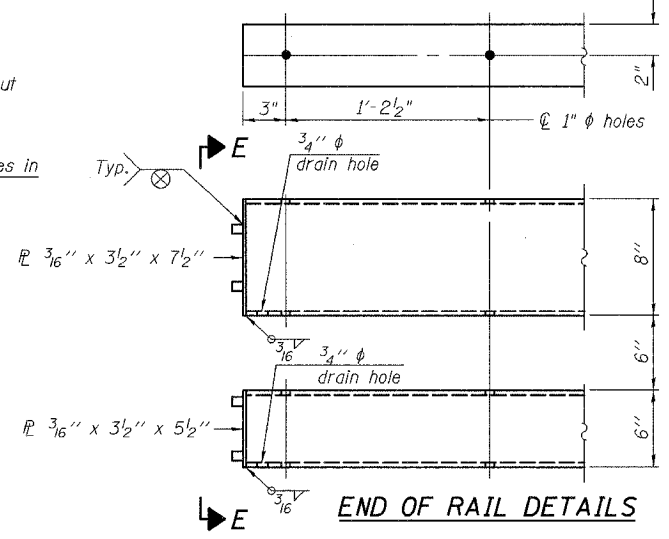

END OF RAIL DETAILS

Notes:
All field drilled holes shall be coated with an approved zinc rich paint before erection.
For multi-span bridges, sufficient 1/4" x 6" x 1'-2" galvanized steel shims shall be provided to align rail between adjacent spans. Cost included with Steel Railing, Type SM.
Steel rail elements shall be galvanized according to Article 509.05 of the Standard Specifications.
** The studs of the anchor devices shall be placed below the top reinforcement bars and the outermost longitudinal reinforcement bar shall be placed directly above the studs of the rail post anchor device.

BILL OF MATERIAL

Item	Unit	Quantity
Steel Railing, Type SM	Foot	155

rjngroup
Excellence through Ownership
200 West Front Street
Wheaton, IL 60187

ILLINOIS DEPARTMENT OF TRANSPORTATION
STEEL RAILING, TYPE SM WITH
CONCRETE WEARING SURFACE
IL-70 OVER TRIBUTARY TO PECATONICA RIVER
FAS RTE 55
SECTION (102 BR-1, 102 BR-2, 102 BR-3)D
WINNEBAGO COUNTY - STATION 302+76.80
STRUCTURE NO. 101-0146
DATE: 12/15/2006
DRAWN BY LCM
CHECKED BY BLB

* Threaded areas shall be plugged or blocked off during casting of beam. Galvanized after fabrication.

12/14/2006 ka:\1179212\structures\BR-0146.dgn