

ROUTE NO.	SECTION	COUNTY	TOTAL SHEETS	SHEET NO.	SHEET NO. 10
FAI 72	*	SANGAMON	559	329	21 SHEETS
FAU 8071					
FED. ROAD DIST. NO. 7	ILLINOIS	FED. AID PROJECT			

(84-9-4)A,HBK,BY,BY-1 Contract No 72541

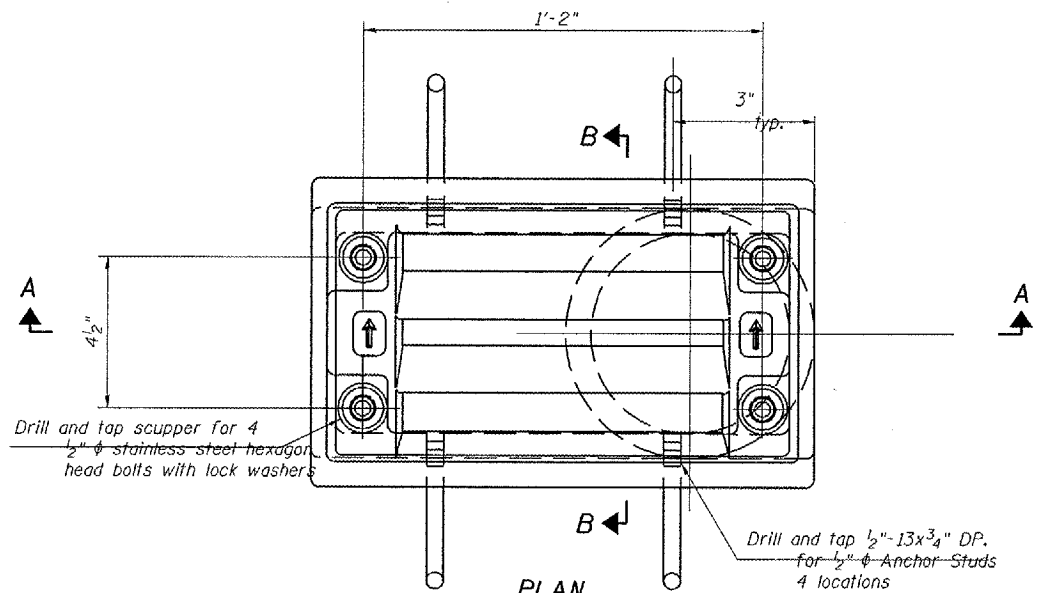

PLAN

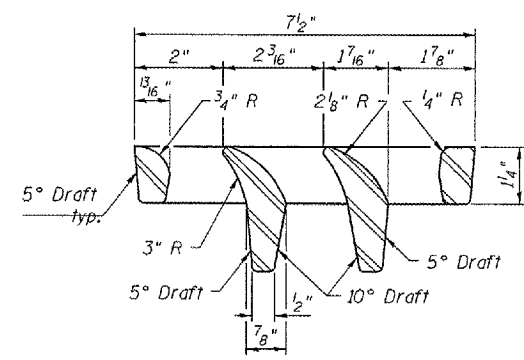

VANE GRATE DETAIL

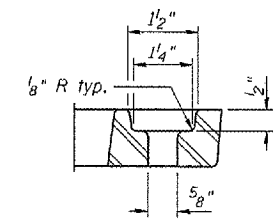

BOLT HOLE DETAIL

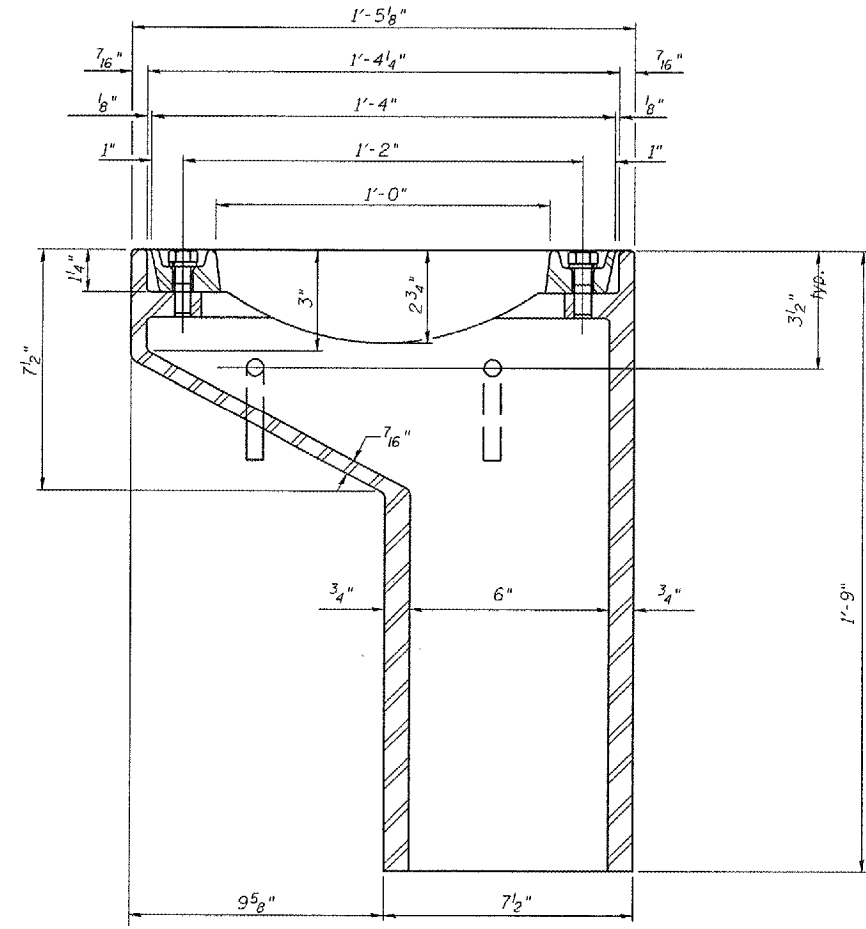

SECTION A-A
See sheet 01 for scupper location relative to parapet.

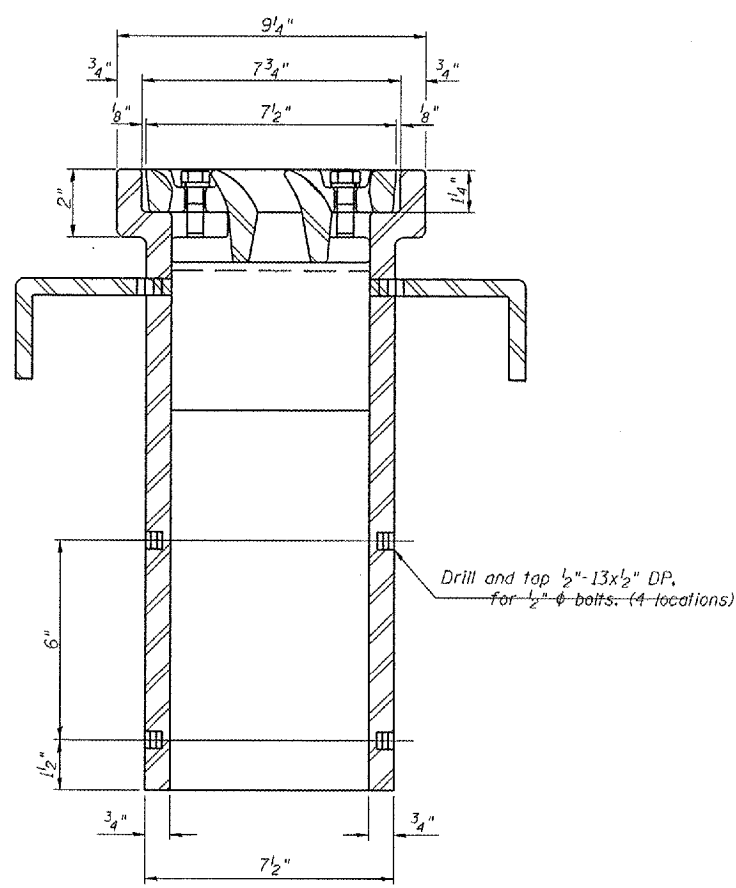

SECTION B-B

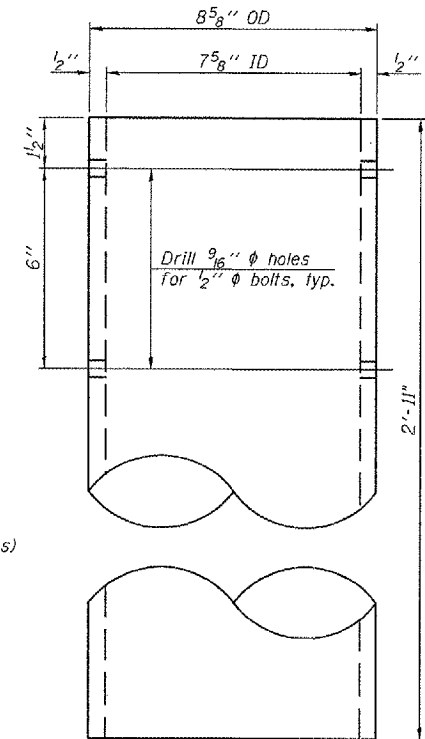

DOWNSPOUT

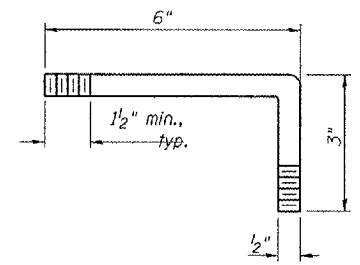

ANCHOR STUD DETAIL

BILL OF MATERIAL

ITEM	UNIT	QUANTITY
Drainage Scupper, DS-11	Each	2

Corporate License Number 184-001-084

DRAINAGE SCUPPER, DS-11
I-72/MACARTHUR BLVD. RAMP C OVER UPRR
SECTION (84-9-4)A,HBK,BY,BY-1
SANGAMON COUNTY
STATION 46+01.97
STRUCTURE NUMBER 084-0516

© Copyright Hanson Professional Services Inc. SMS_YEAR# JOB#



96S2002B
DATE 11/16/05

FILES SORTED

LAYOUT	MMW	06/27/03
DRAWN	DAP	01/04/05
REVIEWED	JWM	02/24/05

DS-11

11-1-06