

FAU ROUTE	SECTION	COUNTY	TOTAL SHEETS	SHEET NO.
8071	*	SANGAMON	559	186
STA. 8071		TO STA.		
FED. ROAD DIST. NO.		ILLINOIS FED. AID PROJECT		
(84-9-4)A,HBK,BY,BY-1		* 02-00382-02-PV		

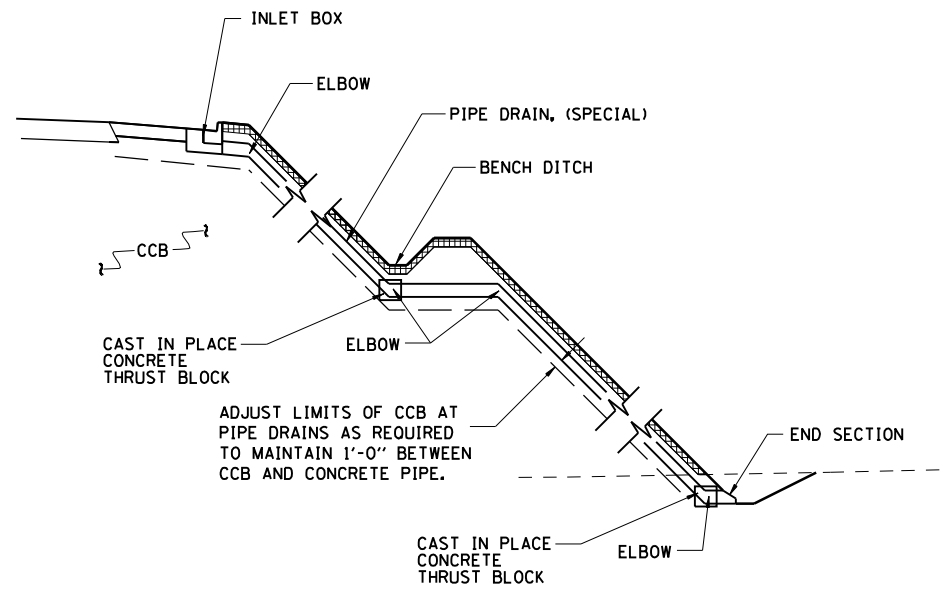

NOTE:  
ALL ELBOWS AND THRUST BLOCKS SHALL BE INCLUDED IN THE CONTRACT UNIT PRICE BID FOR PIPE DRAIN, (SPECIAL) OF THE TYPE AND SIZE SPECIFIED

PIPE DRAINS @ BENCH  
NOT TO SCALE

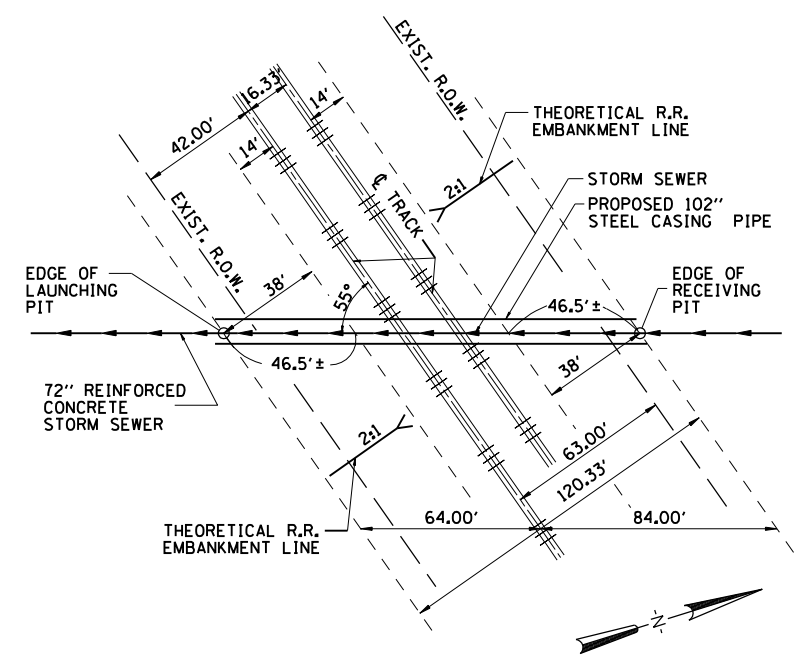

PLAN  
MACARTHUR BOULEVARD STORM SEWER BENEATH  
NORFOLK SOUTHERN RAILWAY  
NOT TO SCALE

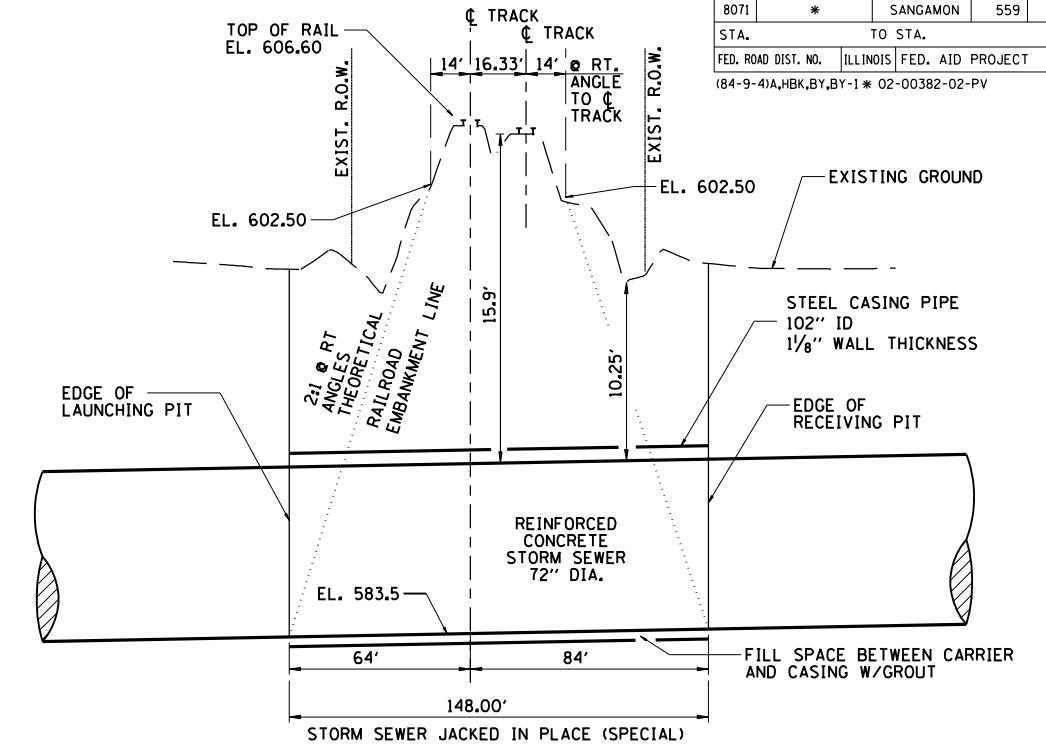

ELEVATION  
MACARTHUR BOULEVARD STORM SEWER BENEATH  
NORFOLK SOUTHERN RAILWAY  
NOT TO SCALE

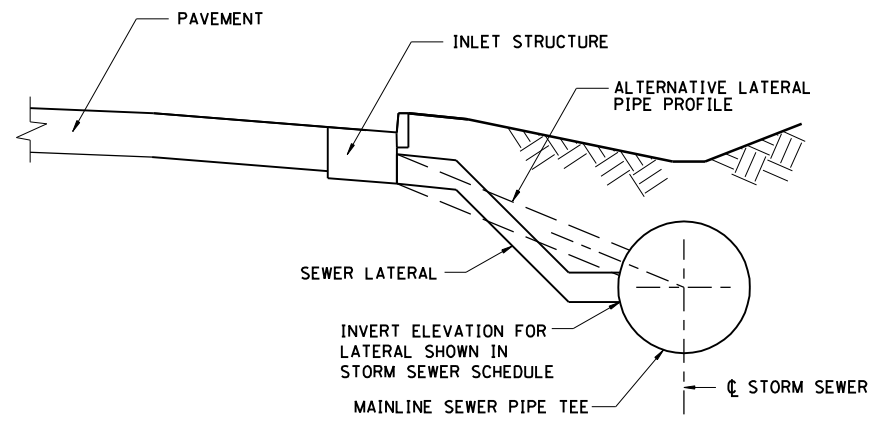

STORM SEWER LATERAL @ PIPE TEE  
NOT TO SCALE

NOTE:  
SEWER LATERAL PIPE ELBOWS, IF REQUIRED, WILL NOT BE PAID FOR SEPARATELY BUT SHALL BE INCLUDED IN THE COST OF THE LATERAL STORM SEWER OF THE TYPE AND DIAMETER SPECIFIED.

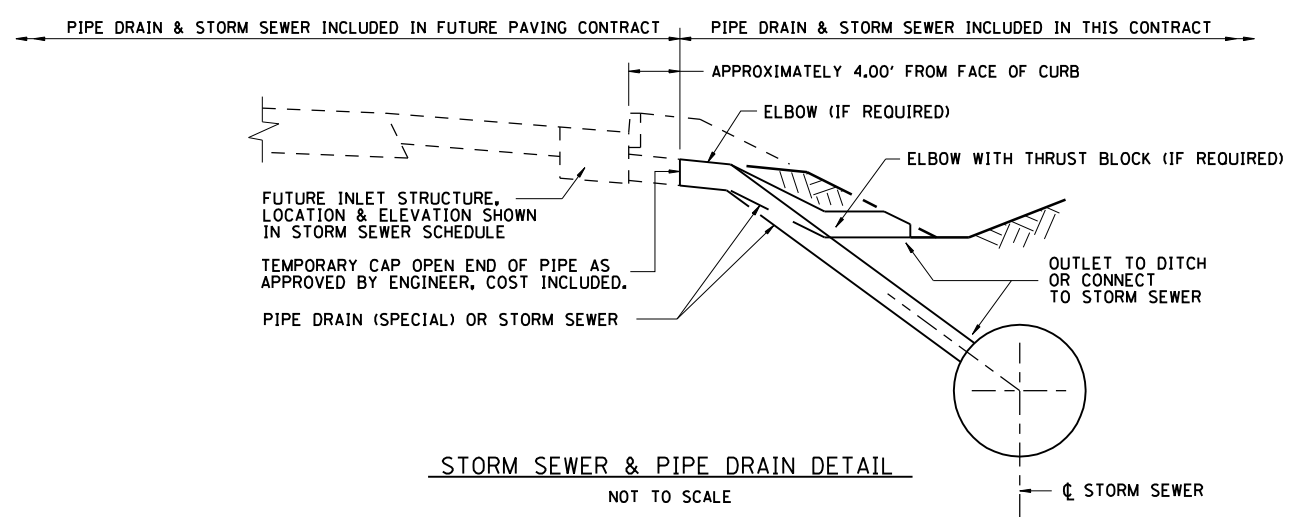

STORM SEWER & PIPE DRAIN DETAIL  
NOT TO SCALE

NOTE:  
ALL ELBOWS & THRUST BLOCKS SHALL BE INCLUDED IN THE CONTRACT UNIT PRICE FOR STORM SEWER OR PIPE DRAIN (SPECIAL) OF THE TYPE & DIAMETER SPECIFIED.

REVISIONS	
NAME	DATE

ILLINOIS DEPARTMENT OF TRANSPORTATION  
PIPE DRAIN & STORM SEWER DETAILS  
FAI-72, MACARTHUR BLVD  
SEC NO. 02-00382-02-PV  
SEC NO. (84-9-4)A,HBK,BY,BY-1  
SANGAMON COUNTY, ILLINOIS  
SCALE: VERT.      DRAWN BY CLG  
          HORIZ.      CHECKED BY JWM  
DATE 12/16/2006



12/16/2006	CLG	08/05/06
\$FILES	CLG	02/05/06
LAYOUT	JMD/JMW	02/05/06
DRAWN		
REVIEWED		