

MEDIAN PLAN

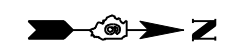

- | | |
|---------------------------------|---------------------------------|
| 1x6- #5 b ₅ (E) bars | 1- #5 b ₆ (E) bar |
| 1x5- #5 b ₆ (E) bars | 1x2- #5 b ₄ (E) bars |
| 1x5- #5 b ₆ (E) bars | 1x2- #5 b ₅ (E) bars |
| 1x5- #5 b ₅ (E) bars | 1x3- #5 b ₄ (E) bars |
| 1x4- #5 b ₆ (E) bars | 1x3- #5 b ₅ (E) bars |
| 1x4- #5 b ₅ (E) bars | 1x3- #5 b ₆ (E) bars |

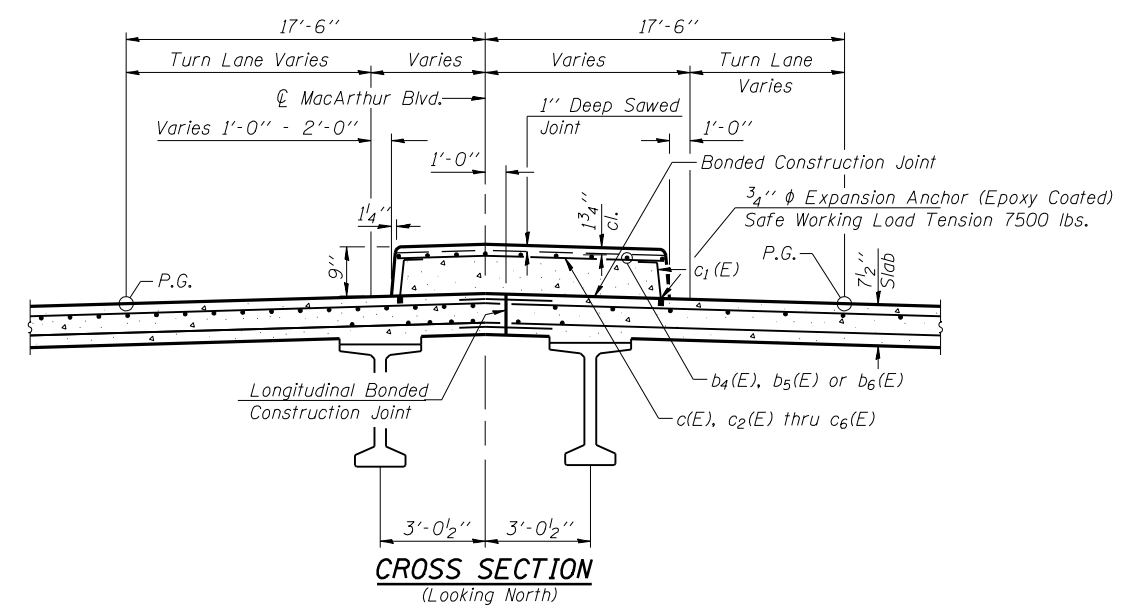

CROSS SECTION
(Looking North)

Notes:
 See Sheet 10 of 24 for superstructure details and Bill of Material.
 Reinforcement bars designated (E) shall be epoxy coated.
 Bars indicated thus 4x3- #5 etc. indicates 4 lines of bars with 3 lengths per line.
 3/4" φ Expansion Anchors (Epoxy Coated) shall be included in the contract unit price per pound of reinforcement bars epoxy coated.

MEDIAN POINTS		
POINT	STATION	OFFSET
'A'	791+66.57	0.74' Lt.
'B'	791+67.44	9.19' Rt.
'C'	793+93.11	17.50' Lt.
'D'	793+95.12	5.50' Rt.

MEDIAN POINTS
(at Back Abutments)

MIN. BAR LAPS
#5 Bar - 2'-2"

Corporate License Number 184-001-084

SUPERSTRUCTURE DETAILS
 MACARTHUR BLVD. OVER F.A.I. 72
 SECTION (84-9-4)A,HBK,BY,BY-1
 SANGAMON COUNTY
 STATION 792+77.64
 STRUCTURE NUMBER 084-0513

© Copyright Hanson Professional Services Inc. \$MS_YEAR\$ JOB# 96S2002B
 DATE 02/02/05

MMW 10/22/04
 DAP 01/04/05
 JMM 02/02/05
 \$FILE\$ 12/16/2006