

**MEDIAN PLAN**

\* Order c5(E) and c6(E) bars full length. Cut to fit skew and use remainder of bars in same end of median.



MEDIAN POINTS			
POINT	STATION	OFFSET	ELEVATION
'A'	799+46.45	14.43' Lt.	640.05
'B'	799+62.90	14.07' Rt.	639.84
'C'	800+12.29	12.97' Lt.	639.16
'D'	800+27.08	12.64' Rt.	638.94
'E'	801+23.72	10.49' Lt.	637.30
'F'	801+35.69	10.23' Rt.	637.08
'G'	801+79.44	9.26' Lt.	636.23
'H'	801+89.99	9.02' Rt.	636.02

**MEDIAN POINTS**  
(at P.G.L.)

Notes:  
See Sheet 10 of 27 for superstructure details and Bill of Material.  
Reinforcement bars designated (E) shall be epoxy coated.  
Bars indicated thus 4x3-#5 etc. indicates 4 lines of bars with 3 lengths per line.  
3/4"  $\phi$  Expansion Anchors (Epoxy Coated) shall be included in the contract unit price per pound of reinforcement bars epoxy coated.

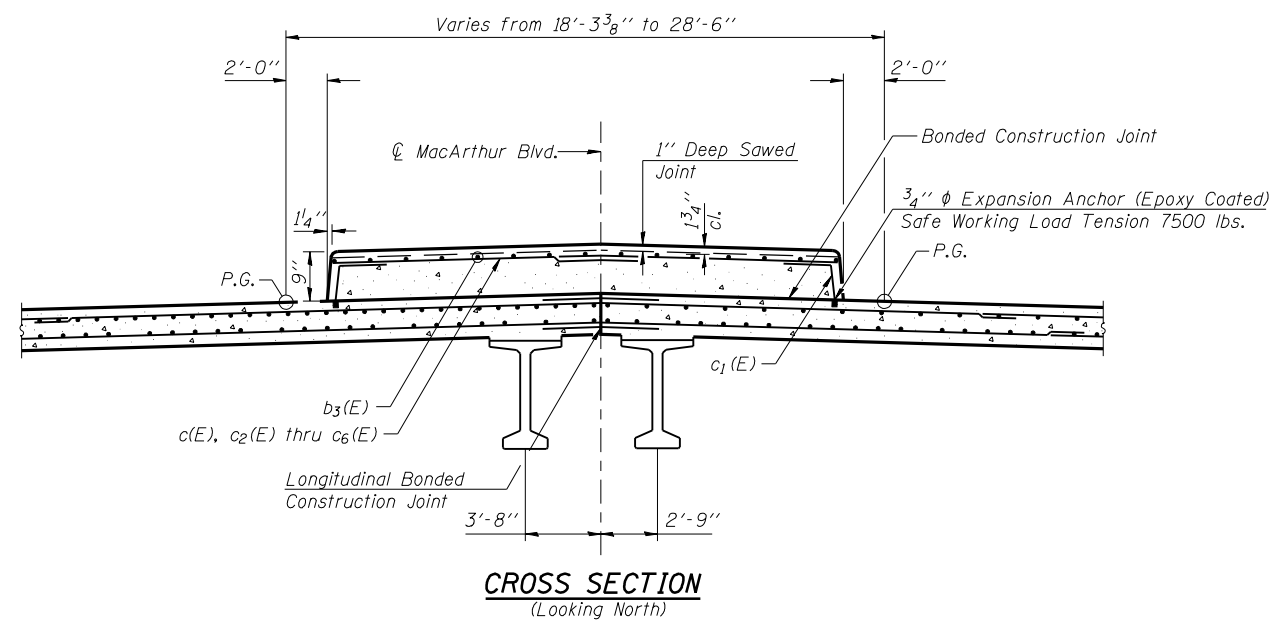

**CROSS SECTION**  
(Looking North)

**MIN. BAR LAPS**  
#5 Bar - 2'-2"

Corporate License Number 184-001-084

**SUPERSTRUCTURE DETAILS**  
**MACARTHUR BLVD. OVER N.S. R.R.**  
**SECTION 02-00382-02-PV**  
**SANGAMON COUNTY**  
**STATION 800+69.78**  
**STRUCTURE NUMBER 084-0512**

© Copyright Hanson Professional Services Inc. \$MS\_YEAR\$



JOB# 96S2002B  
DATE 10/30/05

LAYOUT MWM 06/27/03  
 DRAWN DAP 01/04/05  
 REVIEWED JMM 02/24/05  
 \$FILE\$ 12/16/2006