

ELEVATION AT ABUT.

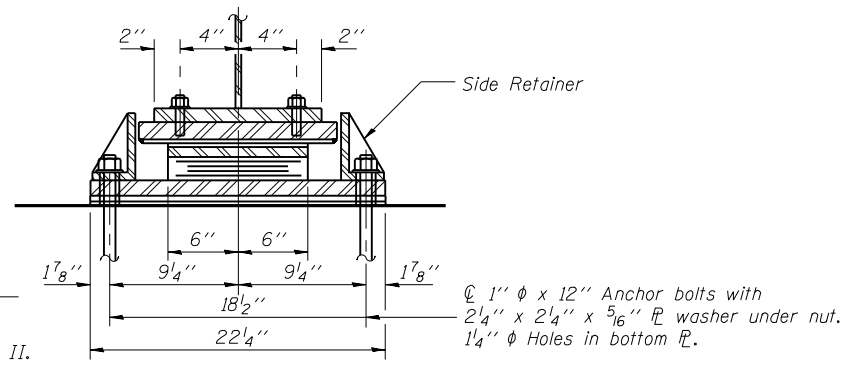

SECTION A-A

TYPE II ELASTOMERIC EXP. BRG.

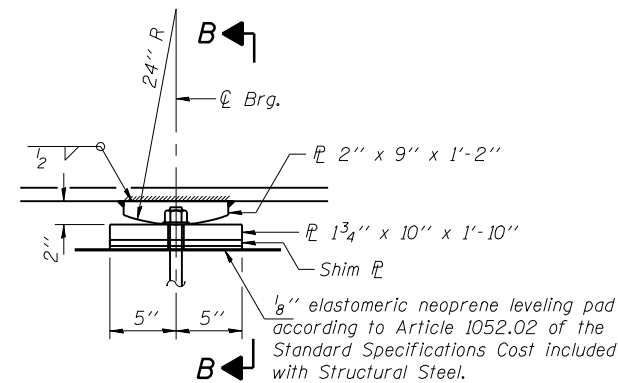

ELEVATION AT PIER

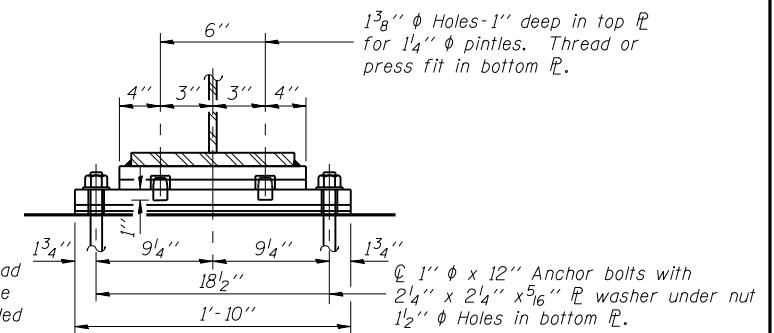

SECTION B-B

FIXED BEARING

No. Required = 15

Notes: Anchor bolts at fixed bearings may be built into the masonry.
See sheet 14 of 22 for Anchor Bolt installation.

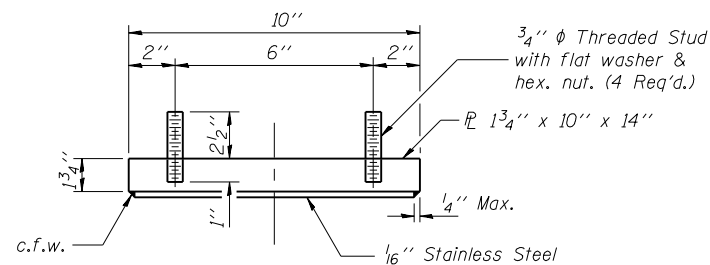

TOP BEARING ASSEMBLY

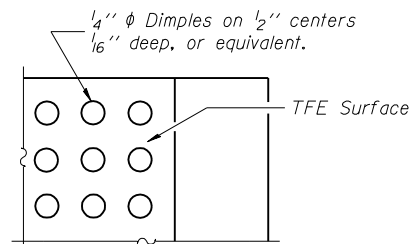

PLAN-TFE SURFACE

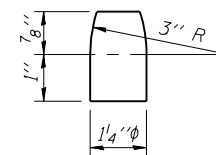

PINTLE

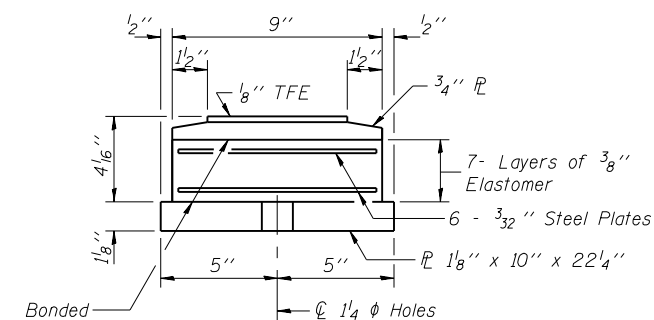

BOTTOM BEARING ASSEMBLY

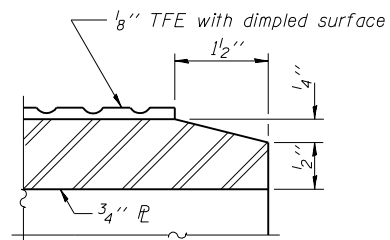

SECTION THRU TFE

Note: The 1/8" TFE sheet shall be bonded directly to the top steel plate with a two-component, medium viscosity epoxy resin, conforming to the requirements of the Federal Specification MMM-A-134, Type I. The bond agent shall be applied on the full area of the contact surfaces.

Bonding of 1/8" TFE sheet during vulcanizing process will be permitted provided the process and method of adjusting assembly height is approved by the Engineer.

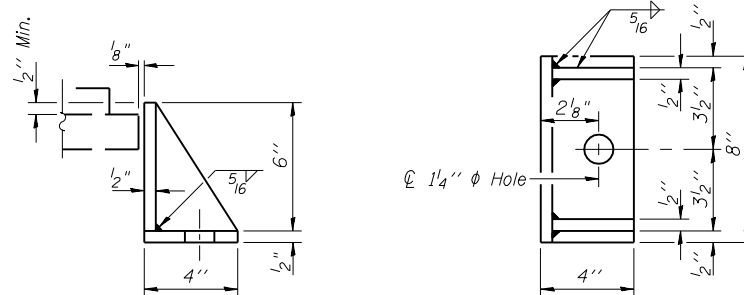

SIDE RETAINER

Equivalent rolled angle with stiffeners will be allowed in lieu of welded plates. Weight included with Structural Steel.

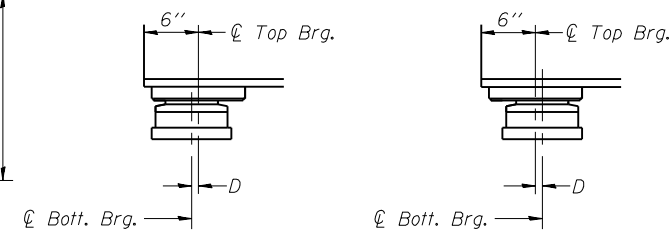

BELOW 50°F.

ABOVE 50°F.

(Move bott. brg. away from fixed brg.) (Move bott. brg. toward fixed brg.)

SETTING ANCHOR BOLTS AT EXP. BRG.

D = 1/8" per each 100' of expansion for every 15° temp. change from the normal temp. of 50°F.

BILL OF MATERIAL

Item	Unit	Total
Elastomeric Bearing Assembly Type II	Each	10

Corporate License Number 184-001-084

ELASTOMERIC BEARING DETAILS, TYPE II
I-72/MACARTHUR BLVD. RAMP B OVER UPRR
SECTION (84-9-4)A, HBK, BY, BY-1
SANGAMON COUNTY
STATION 33+95.61
STRUCTURE NUMBER 084-0514

© Copyright Hanson Professional Services Inc. \$MS_YEAR\$ JOB#



96S2002B

DATE: 11/16/05

LAYOUT: MMJ 06/27/03
DRAWN: DAP 01/04/05
REVIEWED: JMM 02/24/05