

WING WALL ELEVATION
Showing Dimensions

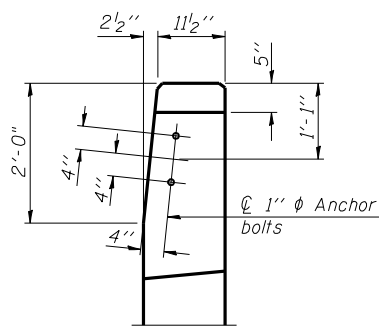

VIEW A-A

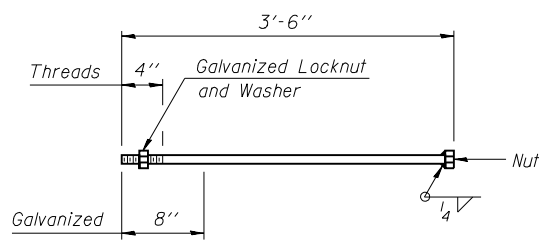

1" diameter ANCHOR BOLT

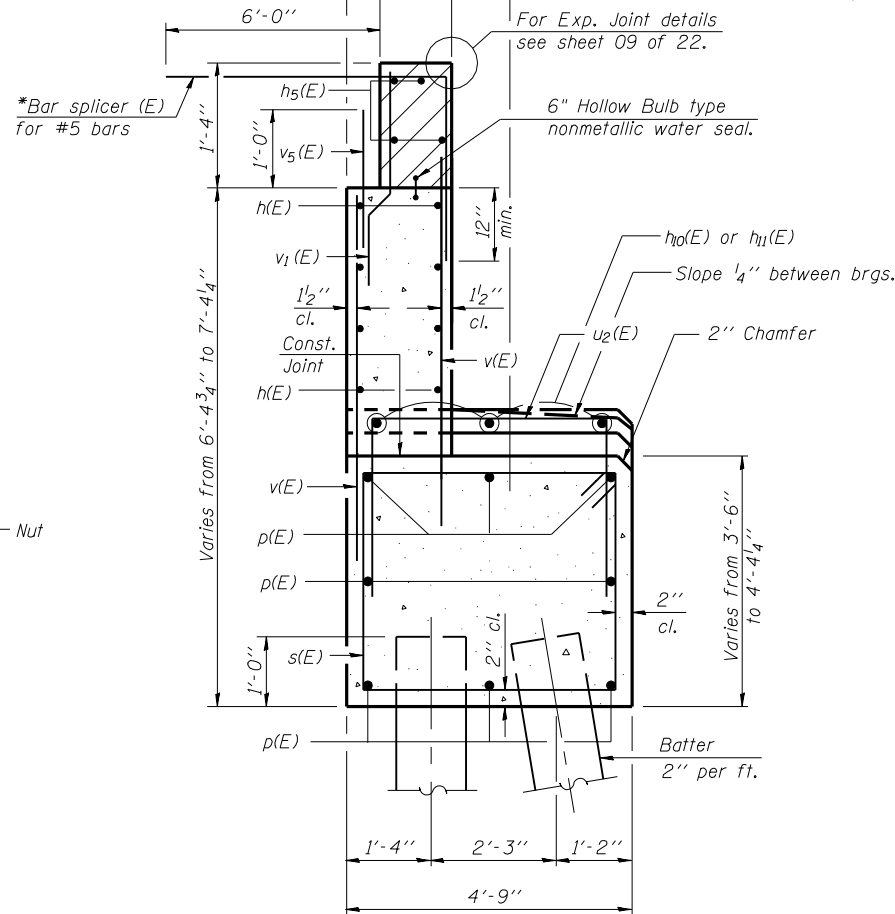

SEC. THRU ABUT.

*Alternate with #4 v(E) bars
Place parallel to the beams

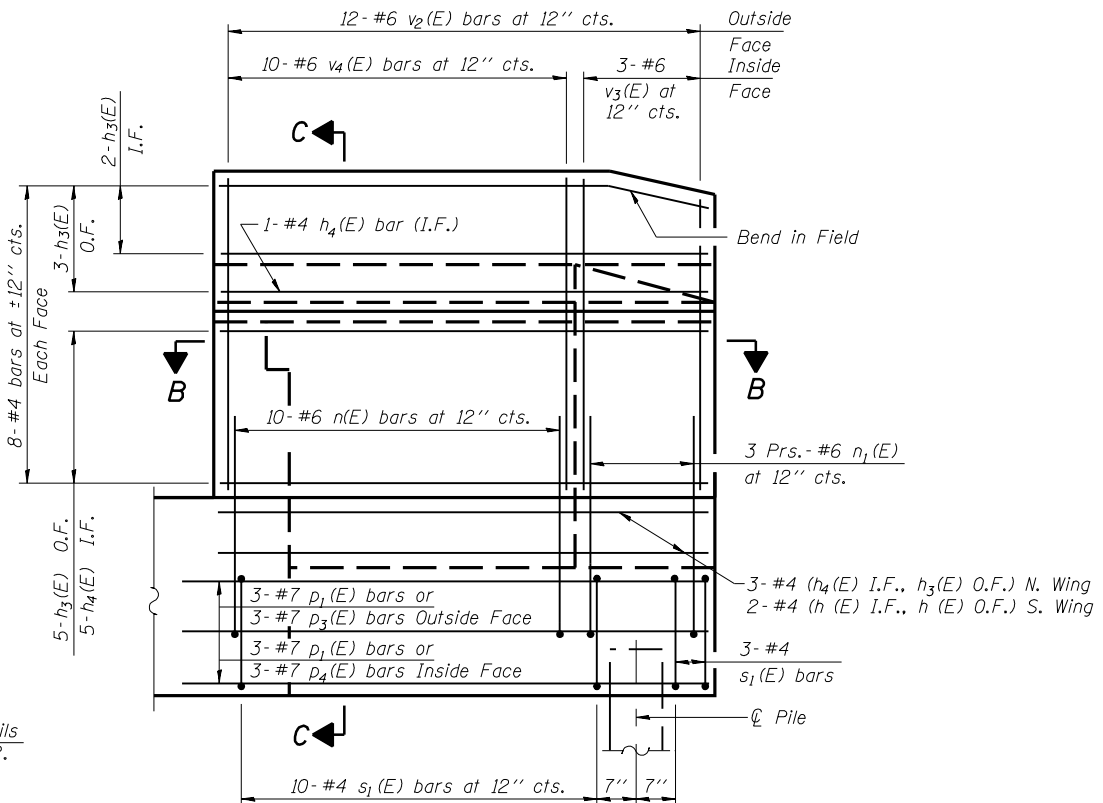

WING WALL ELEVATION
Showing Reinforcement

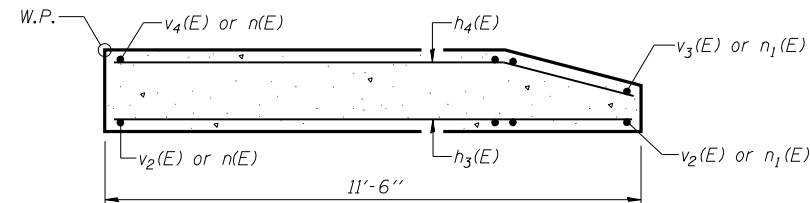

SEC. B-B

Notes: Hatched area to be poured after superstructure forms have been removed. Quantity of concrete included with Concrete Superstructure. Space reinforcement in cap to miss anchor bolts. Pour steps monolithically with cap. Reinforcement bars designated (E) shall be epoxy coated. Quantity of concrete in end post included with Concrete Superstructure on sheet 08 of 22. Conduit is embedded in the South Wing. For details, see Conduit Details sheet in the Roadway Plans.

MIN. BAR LAPS

- #4 Bar - 1'-8"
- #5 Bar - 2'-2"
- #6 Bar - 2'-7"
- #7 Bar - 3'-5"
- #8 Bar - 4'-6"

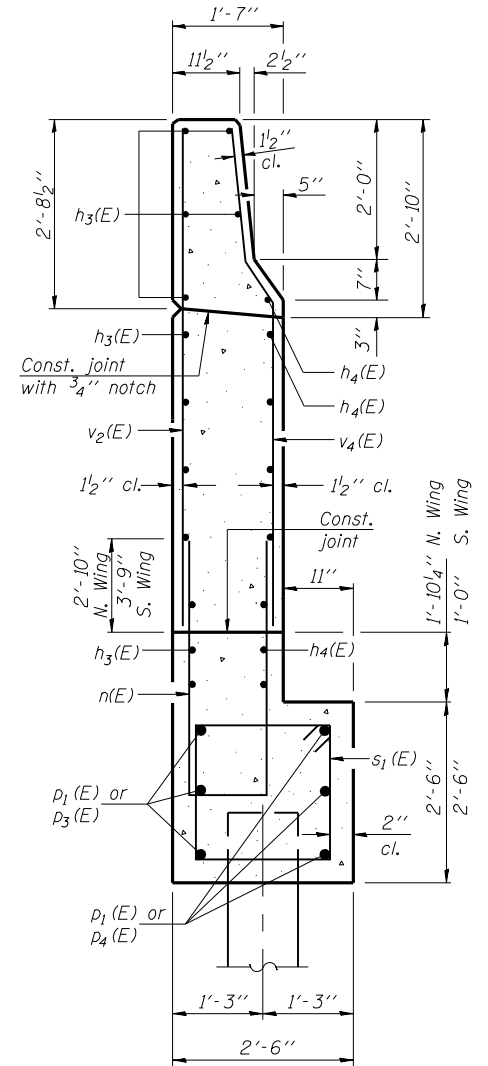

SECTION C-C

Corporate License Number 184-001-084

EAST ABUTMENT DETAILS
I-72/MACARTHUR BLVD. RAMP B OVER UPRR
SECTION (84-9-4)A,HBK,BY,BY-1
SANGAMON COUNTY
STATION 33+95.61
STRUCTURE NUMBER 084-0514

© Copyright Hanson Professional Services Inc. \$MS_YEAR\$



96S2002B

DATE: 11/16/05

s\$FILE\$ 12/16/2006

LAYOUT	JMM	06/27/03
DRAWN	DAP	01/04/05
REVIEWED	JMM	02/24/05