

F.A.P. RTE.	SECTION	COUNTY	TOTAL SHEETS	SHEET NO.
777	405RS-4	MONTGOMERY	75	71
STA. 1075+13.08		TO STA. 1075+25.00		
FED. ROAD DIST. NO.		ILLINOIS FED. AID PROJECT		

105 100 95 90 85 80 75 70 65 60 55 50 45 40 35 30 25 20 15 10 5 0 5 10 15 20 25 30 35 40 45 50 55

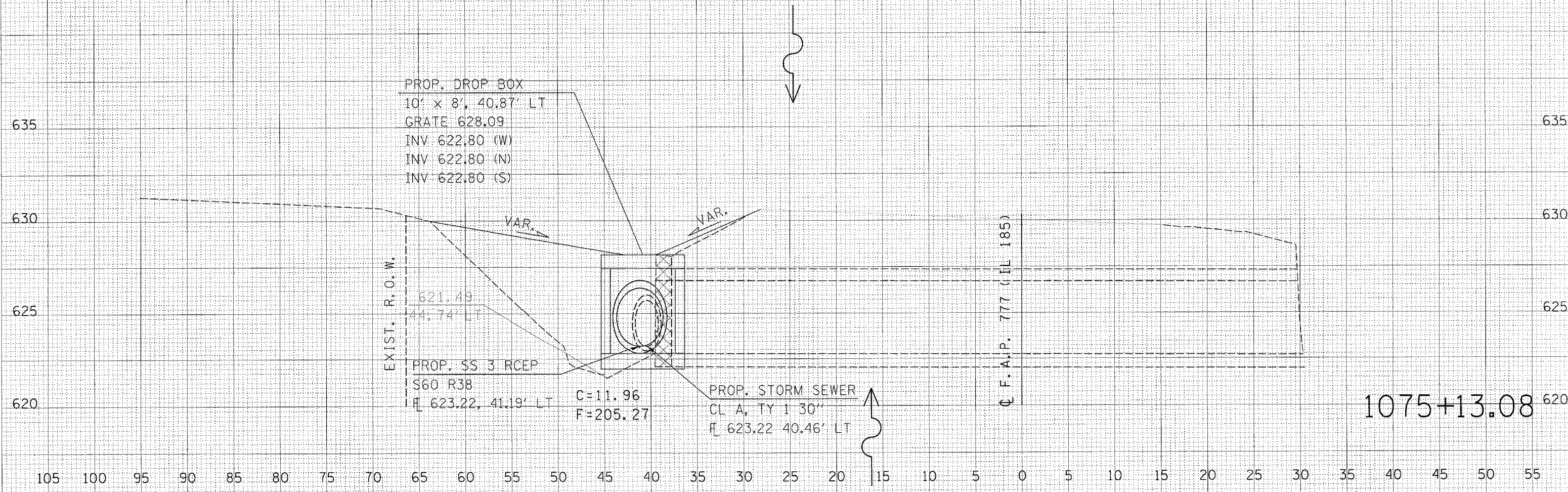
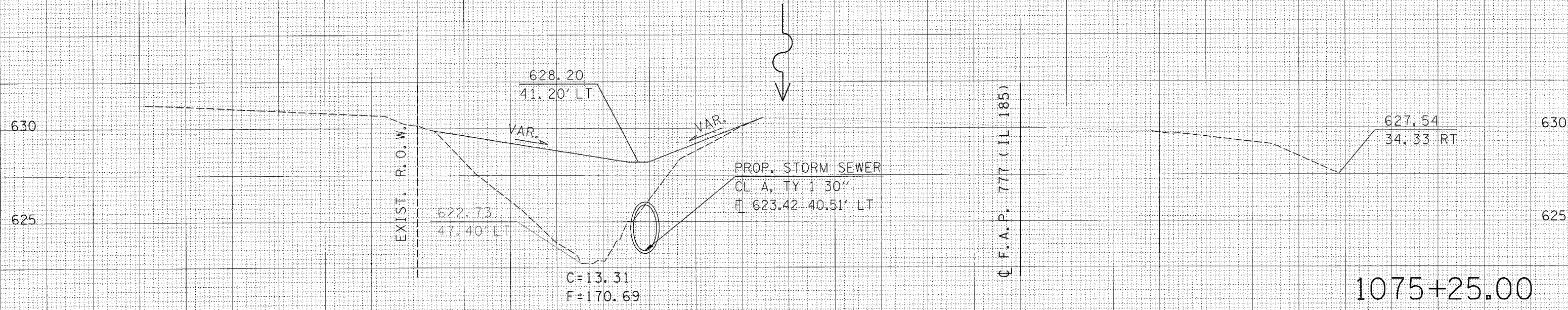

105 100 95 90 85 80 75 70 65 60 55 50 45 40 35 30 25 20 15 10 5 0 5 10 15 20 25 30 35 40 45 50 55

DATE
SURVEY
NOTE BOOK
AREAS CHECKED

DATE
SURVEY
NOTE BOOK
AREAS CHECKED

DATE
SURVEY
NOTE BOOK
AREAS CHECKED