

F.A.P. RTE.	SECTION	COUNTY	TOTAL SHEETS	SHEET NO.
75	*	CHRISTIAN	97	13
STA.		TO STA.		
FED. ROAD DIST. NO.	ILLINOIS	FED. AID PROJECT		

* D 6 RESURFACING 2007

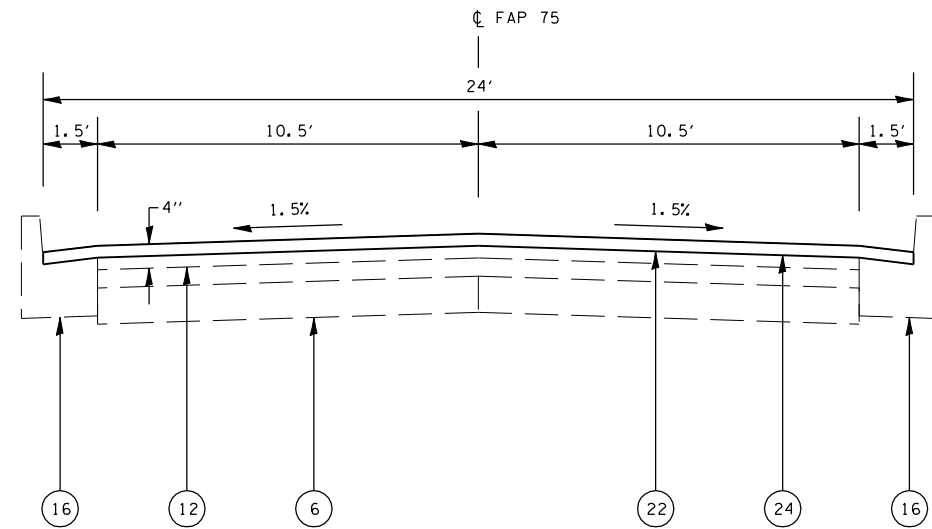

STA 55+36.91 TO STA 56+91.94
STA 65+99.27 TO STA 79+88.63

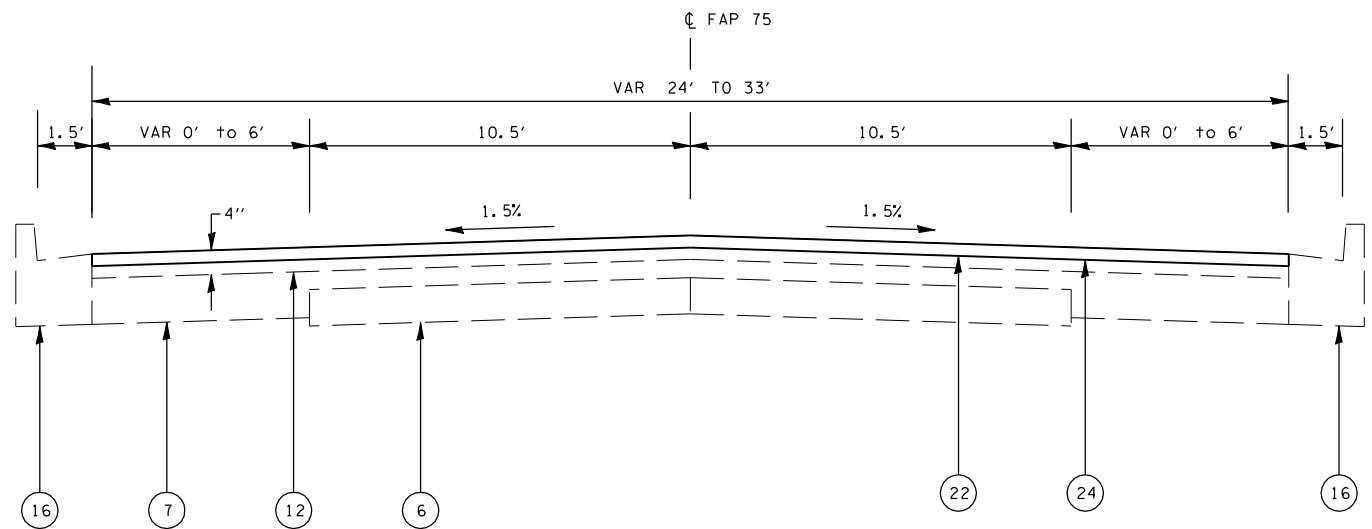

STA 59+45.58 TO STA 60+66.41

LEGEND

- 1 EX SUB-BASE GRANULAR MATERIAL, 4" & VAR
- 2 EX 1/2" DEFORMED BAR AND LONGITUDINAL METAL JOINT
- 3 EX PCC PAVEMENT (9-6-9)
- 4 EX PCC PAVEMENT (9-7-9)
- 5 EX PCC PAVEMENT WITH HOT-MIX ASPHALT
- 6 EX CONCRETE BASE, 6" AND BRICK PAVEMENT, 3"
- 7 EX CONCRETE WIDENING, 8"
- 8 EX PCC BASE COURSE, 9"
- 9 EX CONCRETE WIDENING, 9"
- 10 EX HOT-MIX ASPHALT BASE COURSE, 9" & VAR
- 11 EX HOT-MIX ASPHALT BASE COURSE / WIDENING, 11"
- 12 EX HOT-MIX ASPHALT, VAR DEPTH
- 13 EX CONCRETE MEDIAN, TYPE C-4
- 14 EX CONCRETE MEDIAN SURFACE, 4"
- 15 EX COMBINATION CONCRETE CURB AND GUTTER, TY B-6.06
- 16 EX COMBINATION CONCRETE CURB AND GUTTER, TY B-6.18
- 17 EX COMBINATION CONCRETE CURB AND GUTTER, TY B-6.24
- 18 EX CONCRETE GUTTER, TYPE A
- 19 EX HOT-MIX ASPHALT SHOULDERS, 8"
- 20 EX AGGREGATE SHOULDERS
- 20A EX SIDEWALK
- 21 PR HOT-MIX ASPHALT SURFACE REMOVAL (VAR DEPTH)
- 22 PR HOT-MIX ASPHALT SURFACE REMOVAL, 2"
- 23 PR LEVELING BINDER (MACHINE METHOD), N70
- 24 PR POLYMERIZED HOT-MIX ASPHALT SURFACE COURSE, MIX D, N70, 2"
- 25 PR HOT-MIX ASPHALT SHOULDERS, 2 1/4"
- 26 PR HOT-MIX ASPHALT SHOULDERS, 8"
- 27 PR PAVEMENT MARKING
- 28 PR POLYMERIZED HOT-MIX ASPHALT SURFACE COURSE, MIX D, N70, 1 1/2"
- 29 PR AGGREGATE SHOULDERS, TYPE B

REVISIONS	
NAME	DATE

ILLINOIS DEPARTMENT OF TRANSPORTATION
TYPICAL SECTIONS
FAP 75 (IL 29)
SECTION D 6 RESURFACING 2007
CHRISTIAN COUNTY

SCALE: VERT. / HORIZ.
DATE: / / DRAWN BY: / CHECKED BY: /