

ROUTE NO.	SECTION	COUNTY	TOTAL SHEETS	SHEET NO.
FAU 2732	**	COOK	47	32
ILLINOIS PROJECT		M-8003(712)		
VILLAGE SECTION		00-00115-01-WR		
CONTRACT NO. 83881				

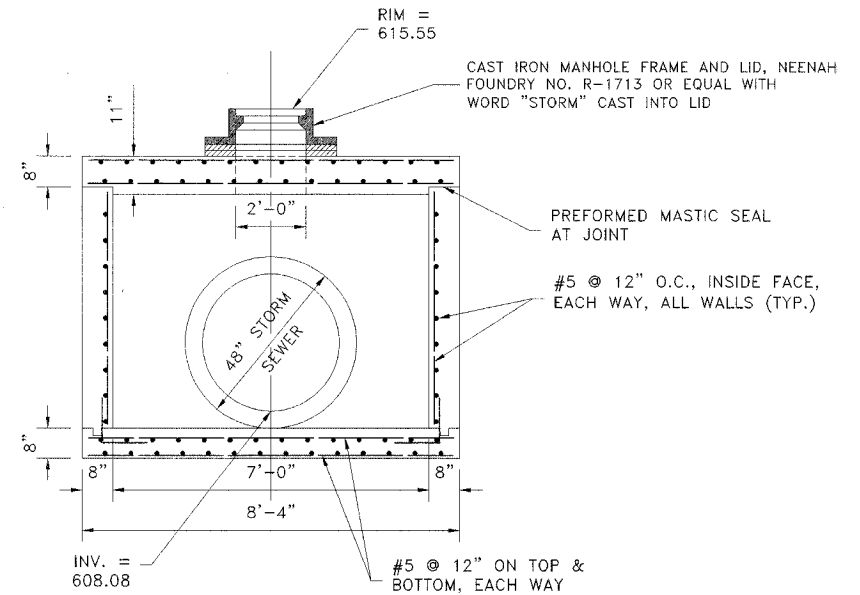

SECTION A-A

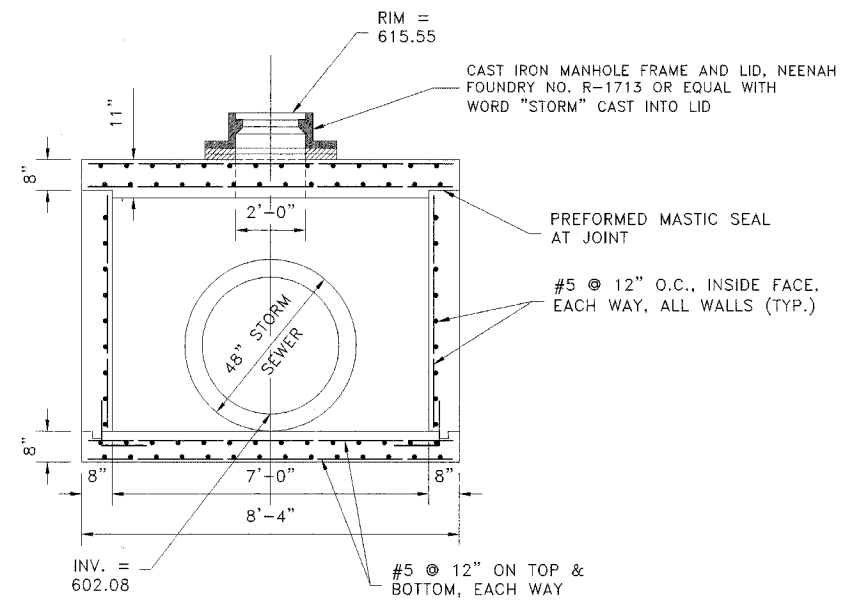

SECTION B-B

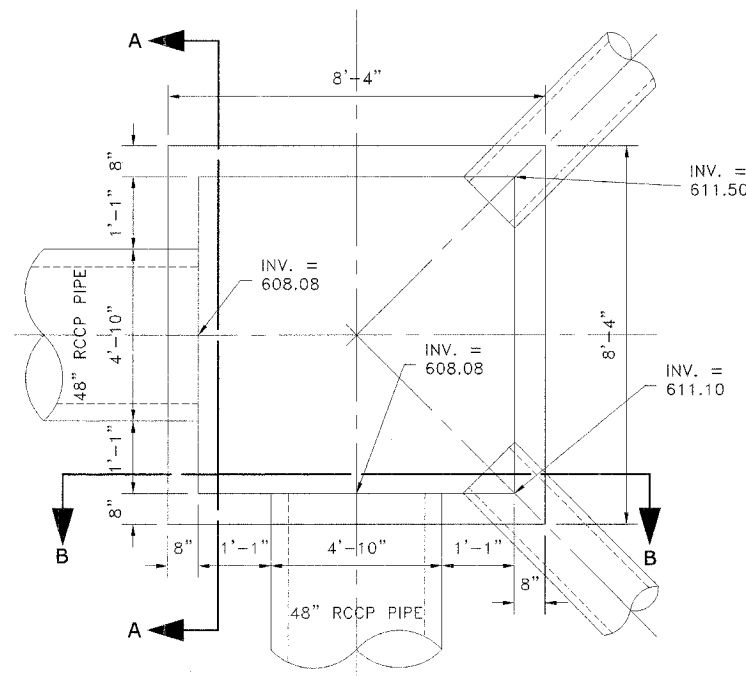

PLAN VIEW

BOX STRUCTURE #30
(SEE SHEET NO. 26)

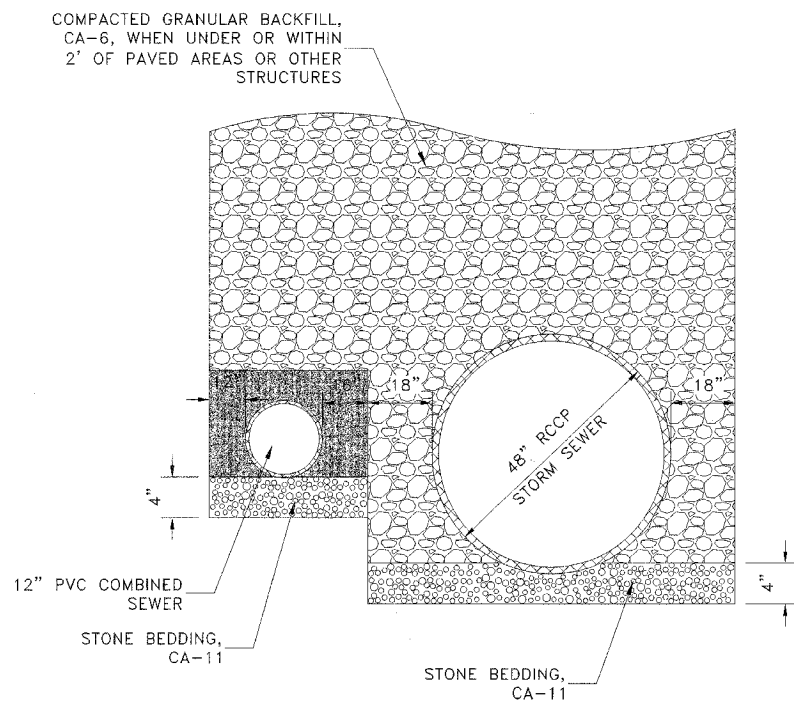

COMBINED SEWER TRENCH
(FOR USE ON FOREST AVENUE, FROM STA. 1+54 TO STA. 4+20)

Drawing File: W:\Projects\12504263 - Prairie Ave 2nd Phase\2010 Project\Drainage-Detail.dwg Jan 18, 2007 - 4:37pm

	Civil Engineers Municipal Consultants Established 1911	9933 Roosevelt Road Westchester, Illinois 60154-2780 Phone: 708/865-0300 Fax: 708/865-1212
	PRAIRIE AVENUE IMPROVEMENTS PHASE II VILLAGE OF BROOKFIELD, ILLINOIS	
	DRAINAGE AND UTILITY DETAILS	
	SCALE: NONE DRAWN BY: MK/LEV BOOK NO.: #1475, #1504 DATE: 10-6-06 REVISION:	

SCALE: NONE	32 OF 47
DRAWN BY: MK/LEV	
BOOK NO.: #1475, #1504	
DATE: 10-6-06	
REVISION:	E.H.E. NO.: 125-04-26301