

GENERAL NOTES

Fasteners shall be AASHTO M164 Type 1, mechanically galvanized bolts. Bolts $\frac{7}{8}$ " ϕ , holes $\frac{5}{16}$ " ϕ , unless otherwise noted.
 Calculated weight of Structural Steel = AASHTO M270 Grade 50 = 326,560 lbs.
 AASHTO M270 Grade 36 = 45,810 lbs.

No field welding is permitted except as specified in the contract documents.
 Reinforcement bars shall conform to the requirements of ASTM A 706 Gr 60 (IL Modified). See Special Provisions

Reinforcement bars designated (E) shall be epoxy coated.
 Bearing seat surfaces shall be constructed or adjusted to their designated elevations within a tolerance of $\frac{1}{8}$ inch (0.01 ft.). Adjustment shall be made either by grinding the surface or by shimming the bearings.

The Inorganic Zinc Rich Primer / Acrylic / Acrylic Paint System shall be used for shop and field painting of new structural steel except where otherwise noted. The color of the final finish coat for all interior steel surfaces shall be gray, Munsell No. 5B 7/1. The color of the final finish coat for the exterior and bottom flange of the fascia beams shall be blue, Munsell No. 10B 3/6. See Special Provision for "Cleaning and Painting New Metal Structures".

The embankment configuration shown shall be the minimum that must be placed and compacted prior to construction of the abutments.

The Contractor shall drive test piles to 110% of the nominal required bearing specified in production locations at substructures specified or approved by the Engineer before ordering the remainder of piles.

The steel H-piles shall be according to AASHTO M270 Grade 50.

The main load carrying member components subject to tensile stress shall conform to the Supplemental Requirements for Notch Toughness Zone 2. These components are the wide flange beams and all splice plate material except fill plates.

The existing structural steel coating contains lead. The Contractor shall take appropriate precautions to deal with the presence of lead on this project.

The Contractor shall remove portions of the existing pier footings to allow driving of the new pier piles. See sheet 3 of 51 for removal details. Cost included with Removal of Existing Structures No. 3 and No. 4.

Cost of removal of the existing slopewall for each structure is included in the pay item Removal of Existing Structures No. 3 or No. 4 respectively.

In addition to all other requirements of Section 512 of the Standard Specifications, splices for HP14x73 piles shall develop the full capacity of the steel's cross sectional area of the pile for tension, shear and bending forces. One approved method of achieving this requirement is full penetration butt welding of the entire cross section. Other types of splices meeting the full capacity requirement may be allowed subject to the approval of the Engineer. Any proposal by the Contractor to use an alternate splice method must include adequate documentation demonstrating that the full tension, shear and bending capacities will be met. Appropriate welder qualifications will be required for the positions and processes used in splicing all piles. Nondestructive testing of completed welds will be limited to visual inspection.

STATE OF ILLINOIS
 DEPARTMENT OF TRANSPORTATION

ROUTE NO.	SECTION	COUNTY	TOTAL SHEETS	SHEET NO.
F.A.I. 57	XI-6-2 VB-2	WILLIAMSON	835	51 SHEETS
FED. ROAD DIST. NO. 7		ILLINOIS	FED. AID PROJECT-	

Contract #98950

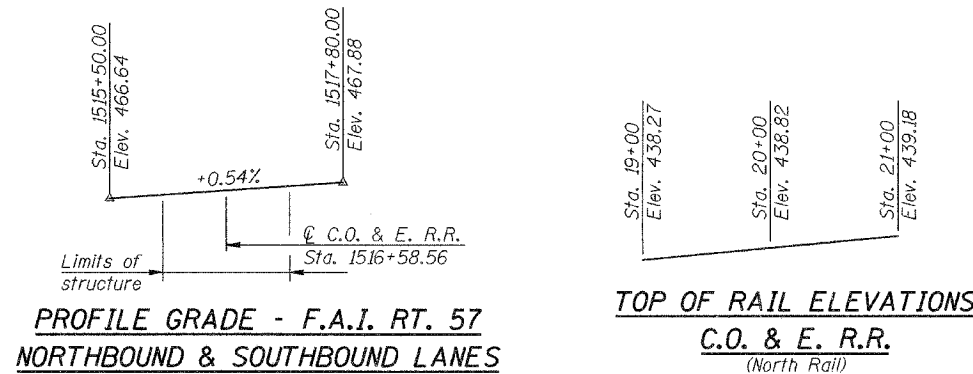

STATION 1516+58.56
 BUILT 200 BY
 STATE OF ILLINOIS
 FAI ROUTE 57 - SEC (XI-6-2)VB-2
 LOADING HL-93
 STR. NO. 100-0086 (N.B.)

STATION 1516+58.56
 BUILT 200 BY
 STATE OF ILLINOIS
 FAI ROUTE 57 - SEC (XI-6-2)VB-2
 LOADING HL-93
 STR. NO. 100-0087 (S.B.)

NAME PLATES
 See Std. 515001

TOTAL BILL OF MATERIAL

ITEM	UNIT	SUPER	SUB	TOTAL
Porous Granular Embankment (Special)	Cu. Yd.			398
** Removal of Existing Structures No. 3	Each			1
** Removal of Existing Structures No. 4	Each			1
Structure Excavation	Cu. Yd.		1248	1248
Concrete Structures	Cu. Yd.		735.5	735.5
Concrete Superstructure	Cu. Yd.	645.6		645.6
Bridge Deck Grooving	Sq. Yd.	2155		2155
Protective Coat	Sq. Yd.	2450		2450
Furnishing and Erecting Structural Steel	LS	0.3		0.3
Stud Shear Connectors	Each	13,041		13,041
Reinforcement Bars, Epoxy Coated	Pound	157,020	60,110	217,130
Bituminous Coated Aggregate Slopewall, 6"	Sq. Yd.			2020
Furnishing Steel Piles HP14x73	Foot		5340	5340
Driving Piles	Foot		5340	5340
Test Pile Steel HP14x73	Each		3	3
Name Plates	Each	2		2
Geocomposite Wall Drain	Sq. Yd.			241
Pipe Underdrains for Structures, 4"	Foot		370	370
Bar Splicers	Each	1180	292	1472
Protective Shield	Sq. Yd.			565
Floor Drains	Each	16		16
Temporary Sheet Piling	Sq. Ft.		700	700
Slopewall, 4"	Sq. Yd.			225.0
Conduit Embedded in Structure, 2" ϕ PVC	Foot	133.0		133.0
Anchor Bolt, 1"	Each		184	184
Concrete Encasement	Cu. Yd.		20.4	20.4
Preformed Joint Seal, 2 1/2"	Foot	133.0		133.0

** Structure No. 3 is Northbound
 ** Structure No. 4 is Southbound

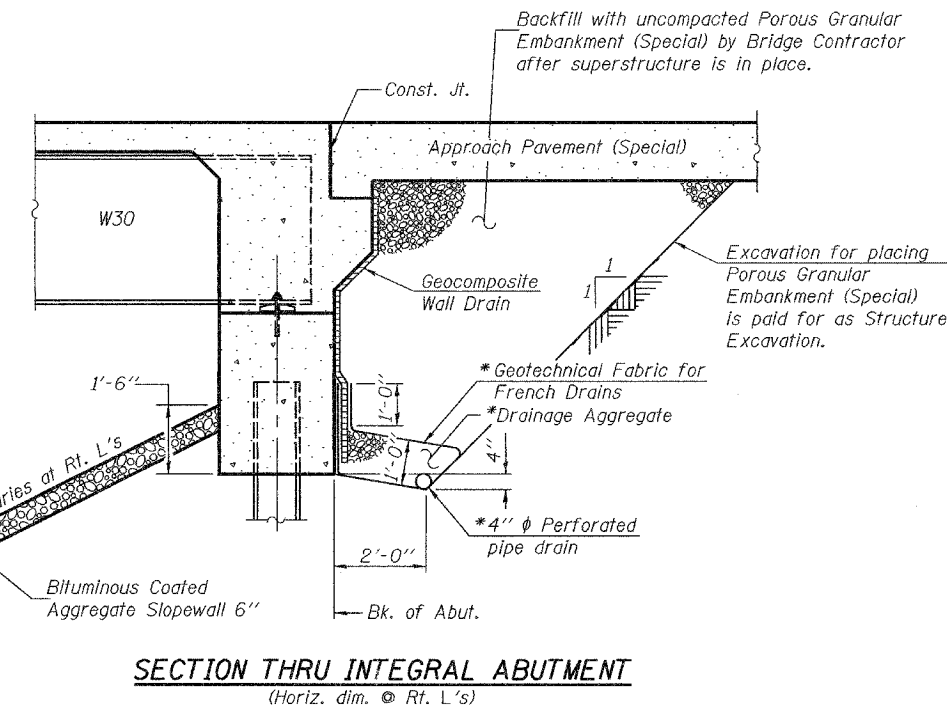

* Included in the cost of Pipe Underdrains for Structures, 4".

Notes:
 All drainage system components shall extend to 2'-0" from the end of each wingwall except an outlet pipe shall extend until intersecting with the side slopes. The pipes shall drain into concrete headwalls. (See Article 601.05 of the Standard Specifications and Highway Standard 601.101).
 Slope wall, 4" shall be reinforced with welded wire fabric, 6" x 6" - W4.0 x W4.0, weighing 58 lbs. per 100 sq. ft.

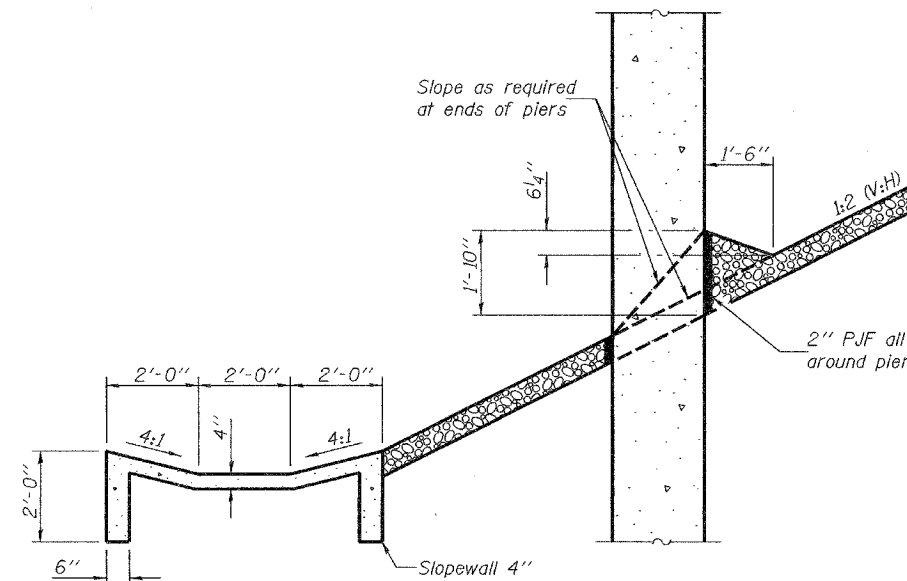
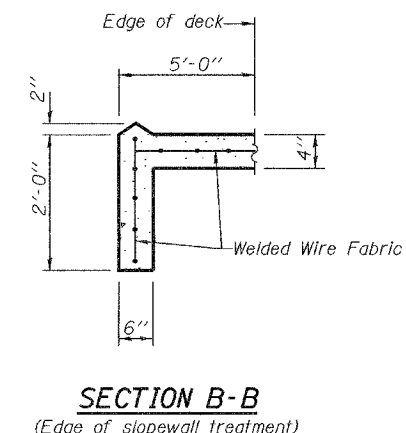
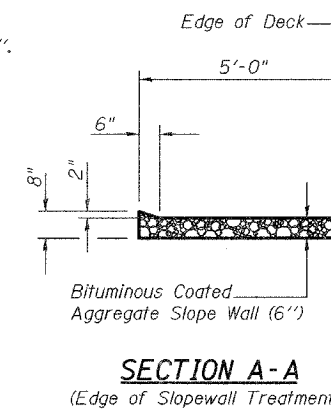

DESIGNED	Michael D. Clima
CHECKED	Fess Teklehaimanot
DRAWN	BECKY M. LEACH
CHECKED	M.D.C. & F.T.

January 22, 2007
 EXAMINED *Thomas J. Donagabaki*
 PASSED *Ralph E. Anderson*

GENERAL DATA
 F.A.I. RT. 57 SEC. (XI-6-2)VB-2
 WILLIAMSON COUNTY
 STA. 1516+58.56
 S.N. 100-0086 (N.B.)
 S.N. 100-0087 (S.B.)