

F.A. RTE.	SECTION	COUNTY	TOTAL SHEETS	SHEET NO.
*	**	WILLIAMSON	917	701
STA. 772+35.2666 TO STA. 772+75.0000				
FED. ROAD DIST. NO. ILLINOIS FED. AID PROJECT				
* I-57, & OLD IL. 13 (FAU 9629)				
** IX1-6-21VB-2, IX1-61HBK-2				

FINAL SURVEY NO. _____

NO. _____

BY _____ DATE _____

SURVEYED _____

NOTE BOOK _____

AREAS CHECKED _____

ORIGINAL SURVEY NO. _____

NO. _____

BY _____ DATE _____

SURVEYED _____

NOTE BOOK _____

AREAS CHECKED _____

PILOT DATE = 10/25/2005
 FILE NAME = c:\projects\98950\old13\old13.dwg
 PLOT SCALE = 5.0000 / 1 IN.
 USER NAME = lavenderba

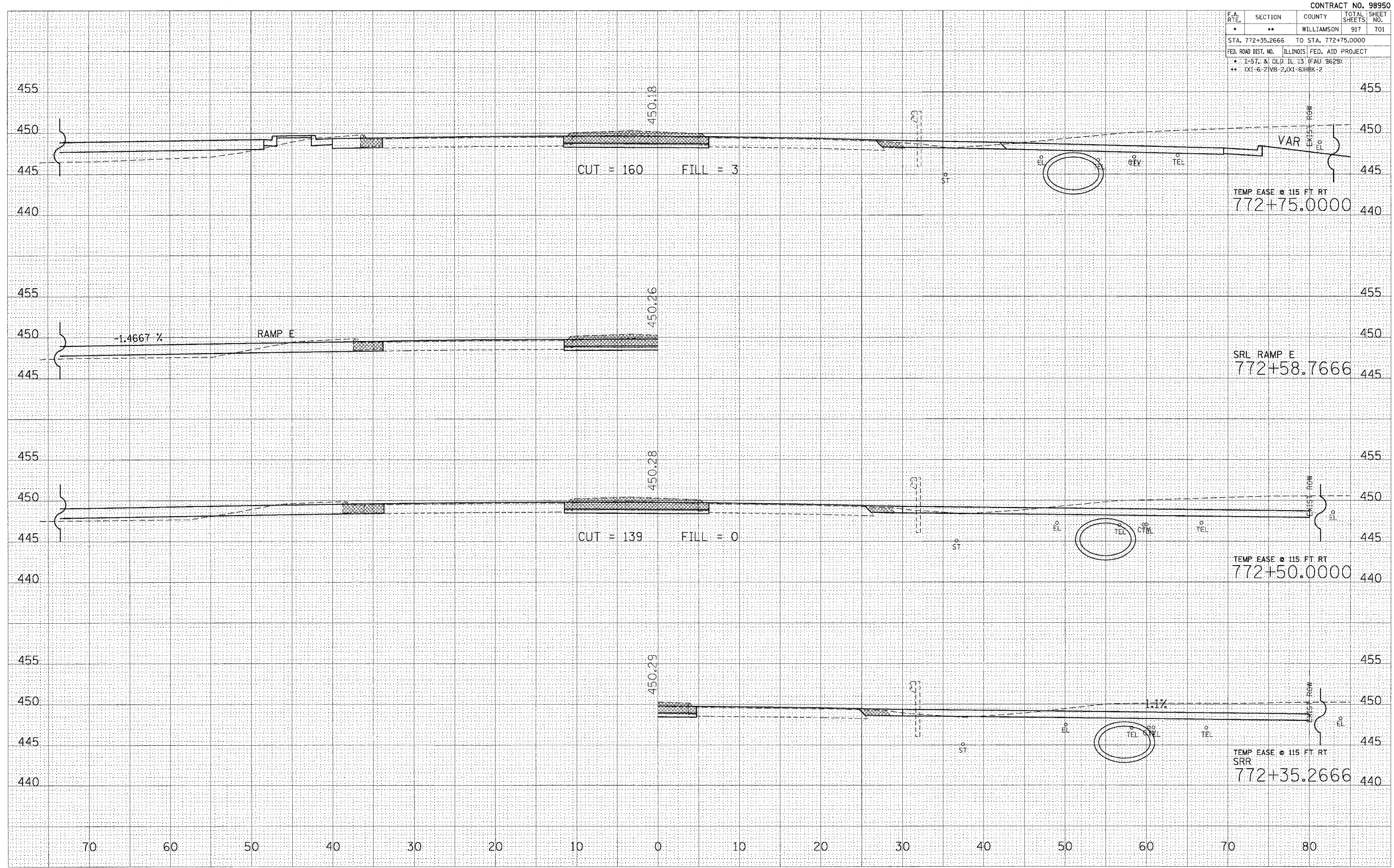

F.A. RTE.	SECTION	COUNTY	TOTAL SHEETS	SHEET NO.
*	**	WILLIAMSON	917	702
STA. 773+00.0000 TO STA. 773+50.0000				
FED. ROAD DIST. NO. ILLINOIS FED. AID PROJECT				
* I-57, & DLD: IL 13 (FAI) 9629				
** (X1-6-2)WB-2,(X1-6)HBK-2				

DATE	BY

SURVEYED
PLOTTED
DATE
AREAS CHECKED

FINAL SURVEY
NOTE BOOK
NO.

DATE	BY

ORIGINAL SURVEY
PLOTTED
DATE
AREAS CHECKED

FINAL SURVEY
NOTE BOOK
NO.

PLOT DATE = 10/26/2006
PLOT SCALE = 5/8" = 1' / IN.
USER NAME = lovendiba

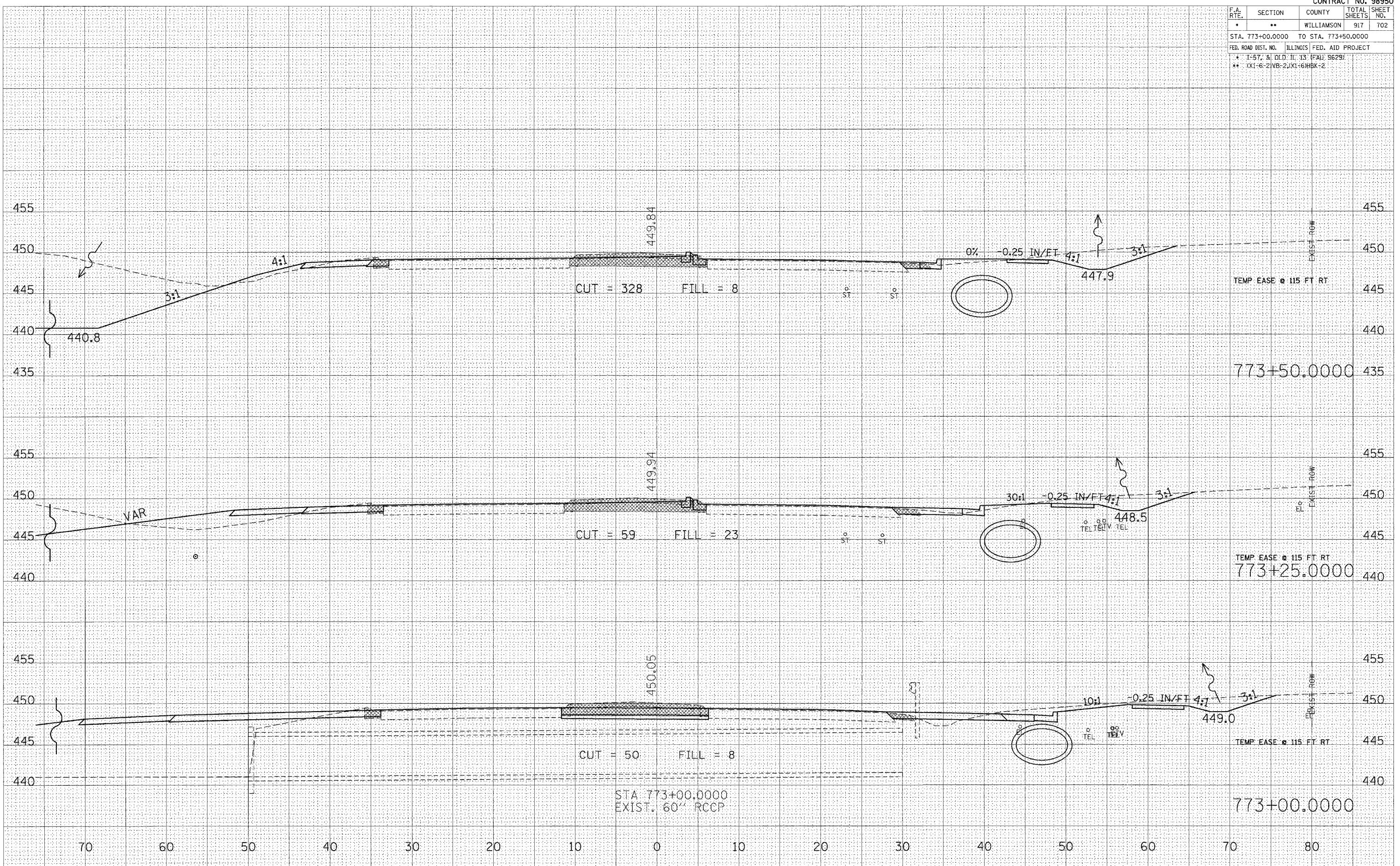

CUT = 328 FILL = 8

CUT = 59 FILL = 23

CUT = 50 FILL = 8

STA 773+00.0000
EXIST. 60" RCCP

F.A. RTE.	SECTION	COUNTY	TOTAL SHEETS	SHEET NO.
*	**	WILLIAMSON	917	703
STA. 773+75.0000 TO STA. 774+25.0000				
FED. ROAD DIST. NO. ILLINOIS FED. AID PROJECT				
* 1-57, & OLD IL 13 (FAU 9629)				
** (X1-6-2)VB-2;(X1-6)HBK-2				

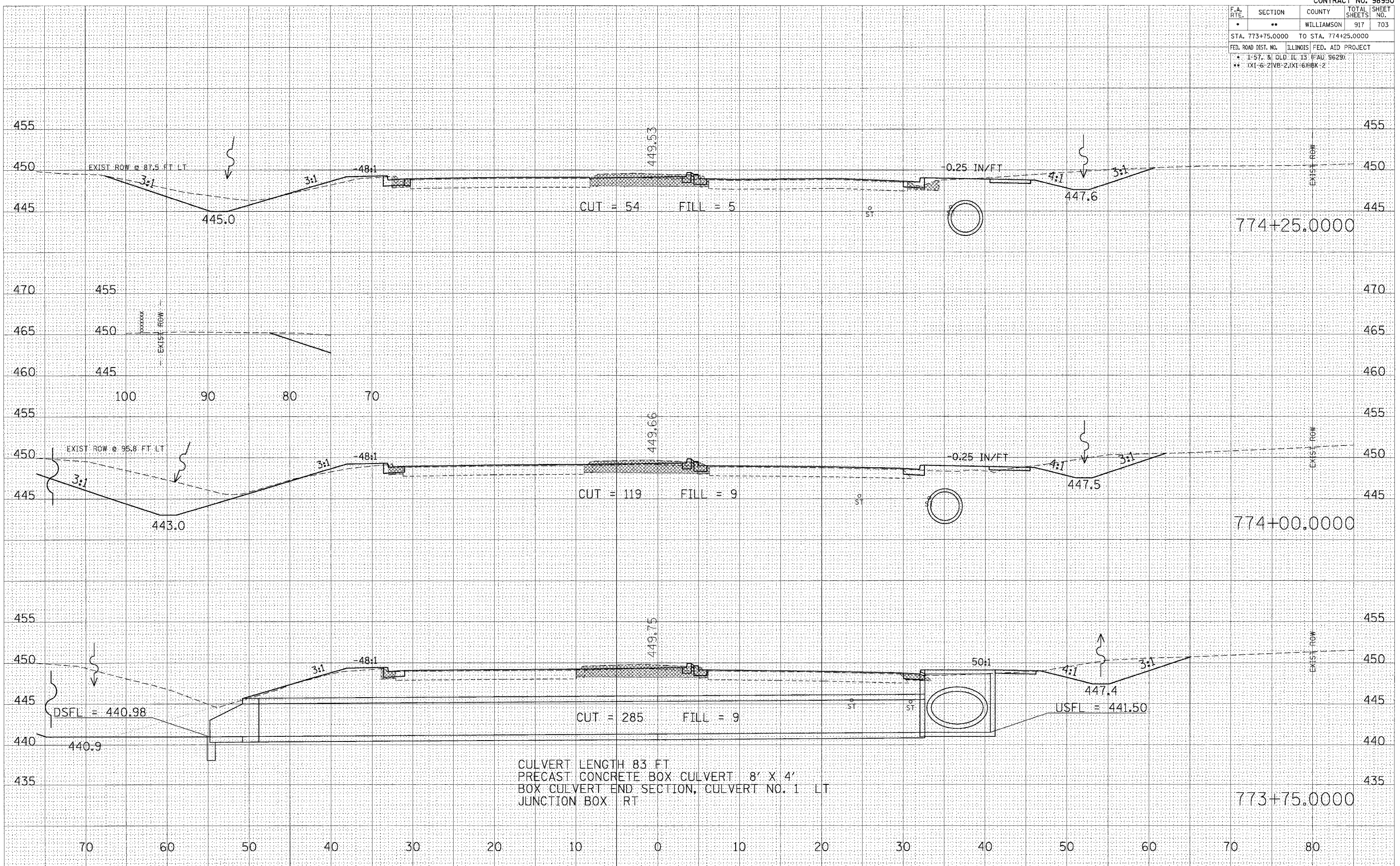

CULVERT LENGTH 83 FT
 PRECAST CONCRETE BOX CULVERT 8' X 4'
 BOX CULVERT END SECTION, CULVERT NO. 1 LT
 JUNCTION BOX RT

DATE	
BY	
NO.	
AREAS CHECKED	
TEMP. PLATE	
NOTE BOOK	
SURVEYED	
FLIML	
SURET	

DATE	
BY	
NO.	
AREAS CHECKED	
TEMP. PLATE	
NOTE BOOK	
SURVEYED	
FLIML	
SURET	

PLT DATE = 10/25/2006
 PLT SCALE = 5/8" = 1'-0"
 USER NAME = jwendrba

F.A. RTE.	SECTION	COUNTY	TOTAL SHEETS	SHEET NO.
*	**	WILLIAMSON	917	704
STA. 774+50.0000 TO STA. 775+00.0000				
FED. ROAD DIST. NO. ILLINOIS FED. AID PROJECT				
* 1-ST, & OLD IL 13 (FAU 9629)				
** (X1-6-21VB-2)(X1-6)HBK-2				

FINAL SURVEY
 BY: _____
 DATE: _____
 SURVEYED
 SURVEY
 NOTE BOOK
 TEMPLATE
 AREAS
 CHECKED

ORIGINAL SURVEY
 BY: _____
 DATE: _____
 SURVEYED
 SURVEY
 NOTE BOOK
 TEMPLATE
 AREAS
 CHECKED

PLOT DATE = 10/25/2005
 FILE NAME = s:\projects\98950\old13\plot\plot.pcb
 PLOT SCALE = 0.6000 / 1 IN.
 USER NAME = lavenderba

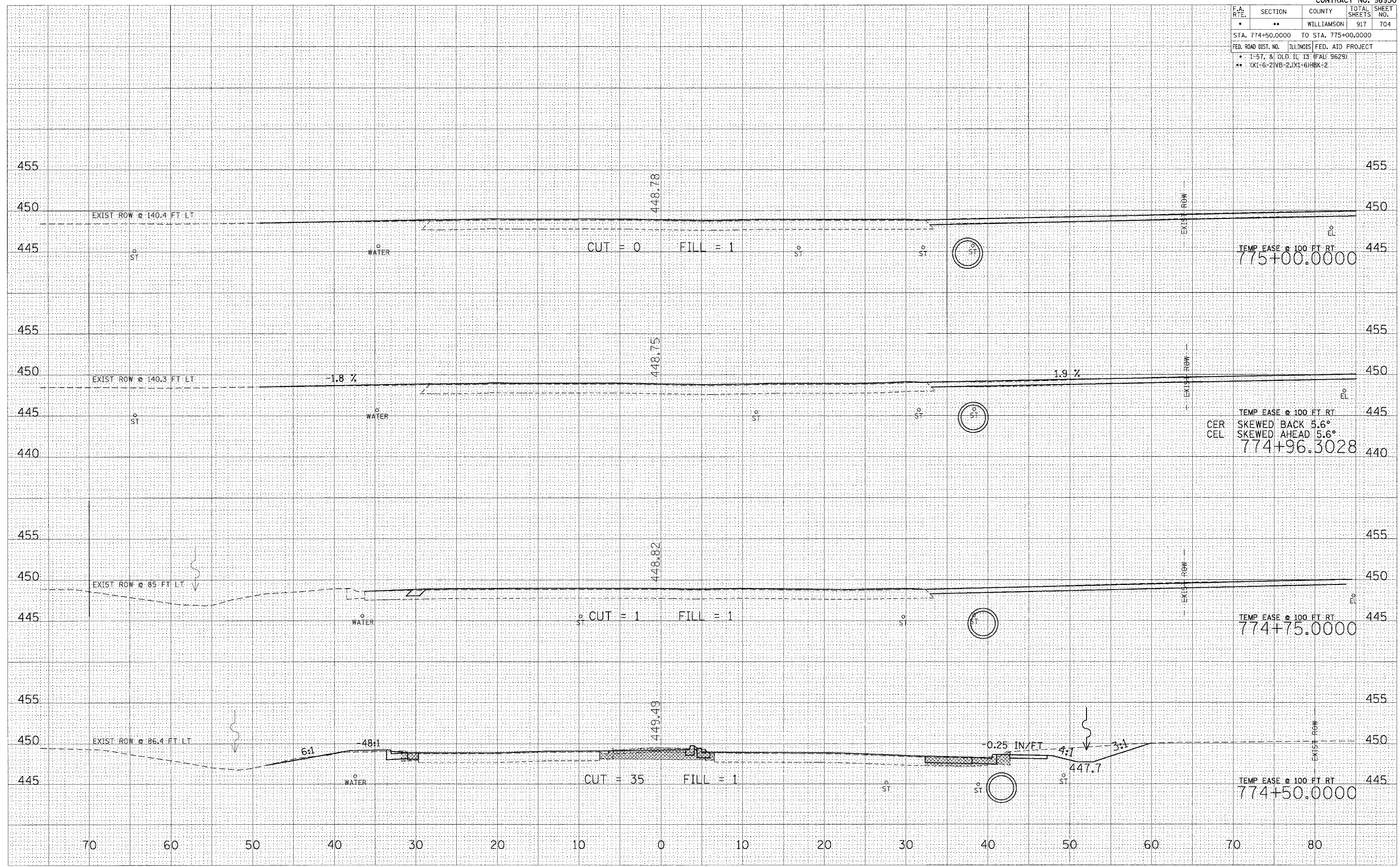

STA 774+50.0000 TO STA 775+00.0000 OLD 13

F.A. RTE.	SECTION	COUNTY	TOTAL SHEETS	SHEET NO.
*	**	WILLIAMSON	917	705
STA. 775+25.0000 TO STA. 776+00.0000				
FED. ROAD DIST. NO. ILLINOIS FED. AID PROJECT				
* 1-57, & OLD-IL-13 (FAU-9629)				
** 0X1-6-2IVB-2/1X1-6IBK-2				

BY	DATE

BY	DATE

ORIGINAL SURVEYED
 SURVEY PLOTTED
 PLOT SCALE = 5/8" = 1'-0"
 USER NAME = lavenderb
 PLOT DATE = 10/25/2006
 PLOT SCALE = 5/8" = 1'-0"
 USER NAME = lavenderb

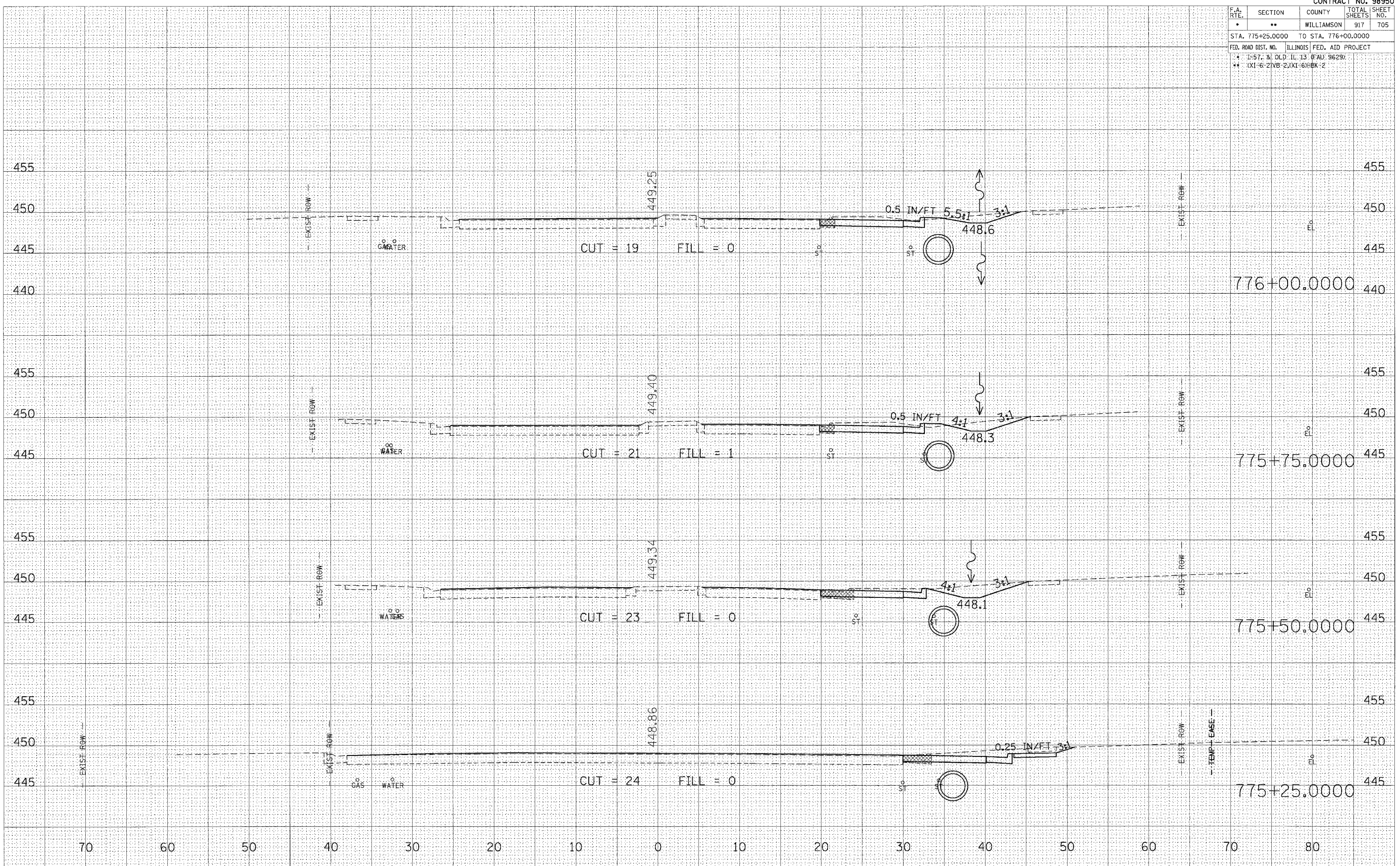

F.A. RTE.	SECTION	COUNTY	TOTAL SHEETS	SHEET NO.
*	**	WILLIAMSON	917	706
STA. 776+25.0000 TO STA. 776+75.0000				
FED. ROAD DIST. NO. ILLINOIS FED. AID PROJECT				
* I-57, & DLD: IL 13 (FAU: 9629)				
** 0X1-6-21WB-2, 0X1-6-HBK-2				

BY	DATE

NO.	AREAS CHECKED

NO.	AREAS CHECKED

BY	DATE

NO.	AREAS CHECKED

NO.	AREAS CHECKED

PRINT DATE = 10/25/2006
PLOT SCALE = 1/8" = 100'
USER NAME = lavenderbo

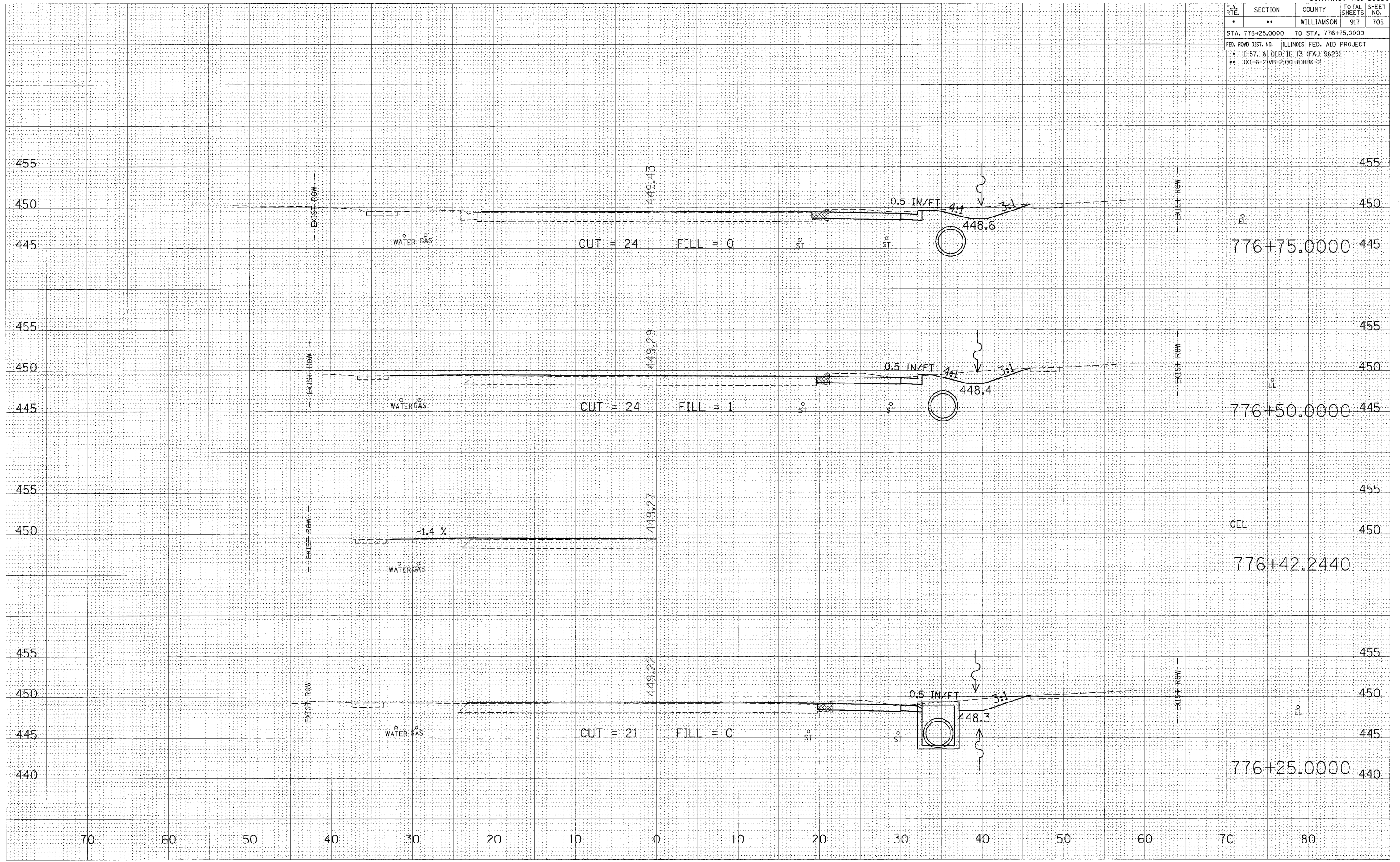

F.A. RTE.	SECTION	COUNTY	TOTAL SHEETS	SHEET NO.
*	**	WILLIAMSON	917	707
STA. 777+00.0000 TO STA. 777+50.0000				
FED. ROAD DIST. NO. ILLINOIS FED. AID PROJECT				
* I-57, & OLD IL 13 (FAU 9629)				
** (X1-6-2)VB-2,(X1-6)HBK-2				

DATE	
BY	
SURVEYED	
PLOTTED	
DATE	
AREAS	
CHECKED	
NO.	

DATE	
BY	
SURVEYED	
PLOTTED	
DATE	
AREAS	
CHECKED	
NO.	

DATE	10/25/2005
BY	INWENDEBS
SURVEYED	
PLOTTED	
DATE	
AREAS	
CHECKED	
NO.	

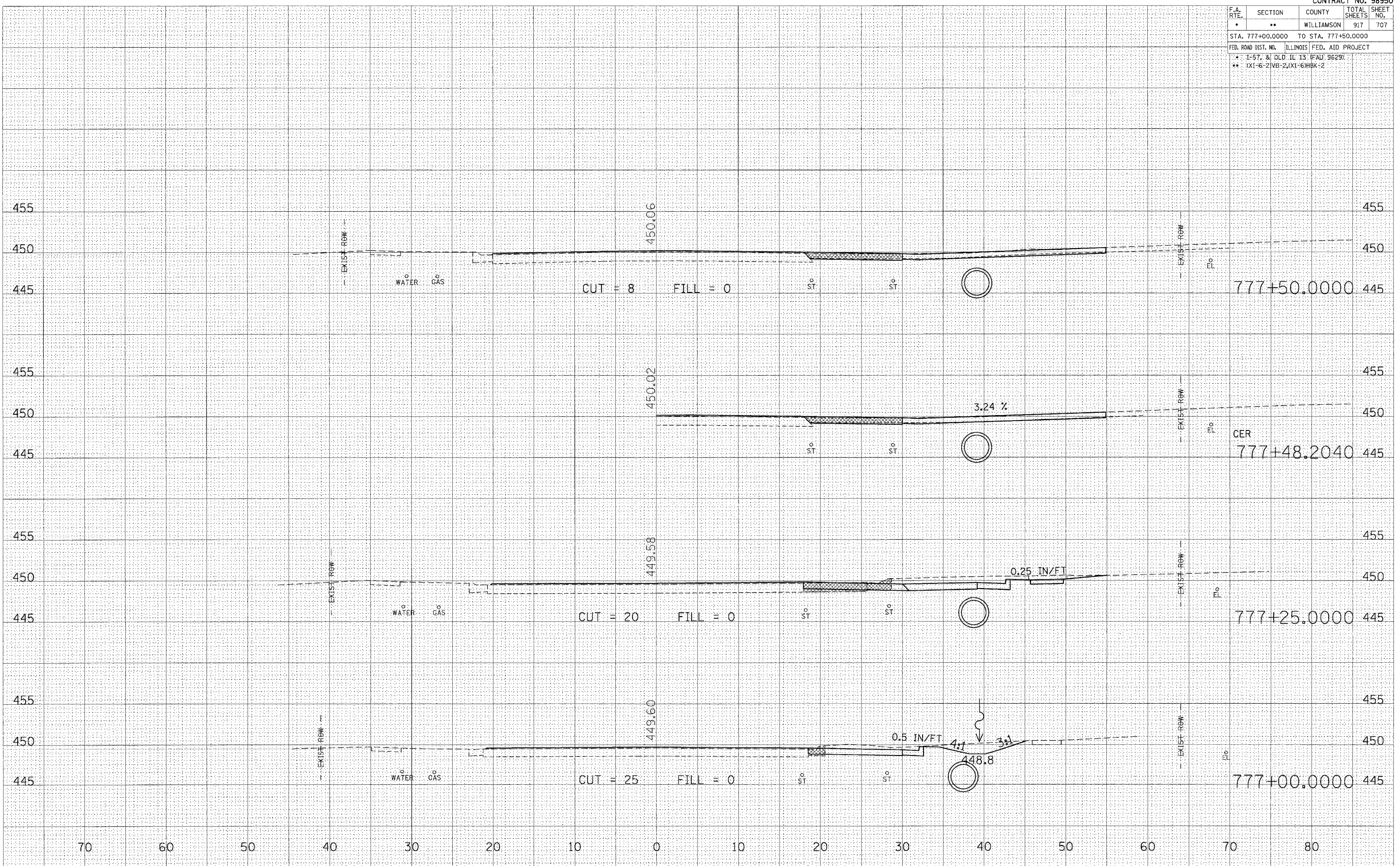

F.A. RTE.	SECTION	COUNTY	TOTAL SHEETS	SHEET NO.
*	**	WILLIAMSON	917	708
STA. 777+75.0000 TO STA. 778+27.1640				
FED. ROAD DIST. NO. ILLINOIS FED. AID PROJECT				
* I-57, & OLD IL. 13 (FAU 9629)				
** (X1-6-2)VB-2,(X1-6)HBK-2				

FINAL SURVEY	DATE
NOTE BOOK	BY
NO.	NO.
AREAS CHECKED	AREAS CHECKED

ORIGINAL SURVEY	DATE
NOTE BOOK	BY
NO.	NO.
AREAS CHECKED	AREAS CHECKED

PLOT DATE = 10/25/2005
 FILE NAME = c:\projects\982302a\old13\old13.dwg
 PLOT SCALE = 1/8" = 1'-0"
 USER NAME = lavanderbe

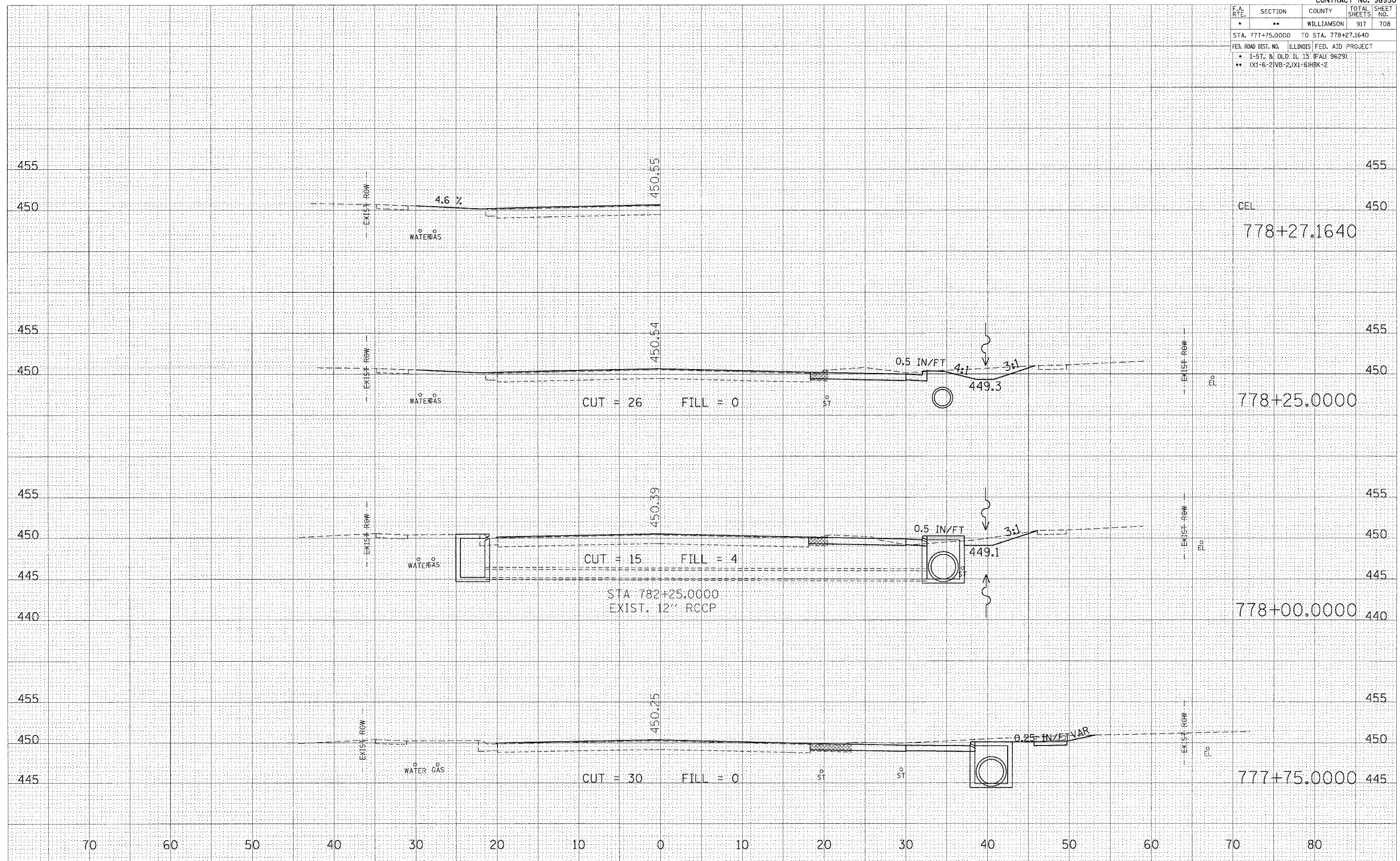

F.A. RTE.	SECTION	COUNTY	TOTAL SHEETS	SHEET NO.
•	••	WILLIAMSON	917	709
STA. 778+50.0000 TO STA. 779+00.0000				
FED. ROAD DIST. NO. ILLINOIS FED. AID PROJECT				
• I-57, & OLD IL. 13 (FAL 9629)				
•• (X1-6-2)VB-2,(X1-6)HBK-2				

DATE	
BY	
SURVEYED	
FINAL SURVEY	
NOTE BOOK	
NO.	
AREAS CHECKED	

DATE	
BY	
SURVEYED	
ORIGINAL SURVEY	
NOTE BOOK	
NO.	
AREAS CHECKED	

PLOT DATE = 10/25/2006
 FILE NAME = c:\prowork\101013\old13\old13.dwg
 PLOT SCALE = 5.0000" / 1"
 USER NAME = lavenderba

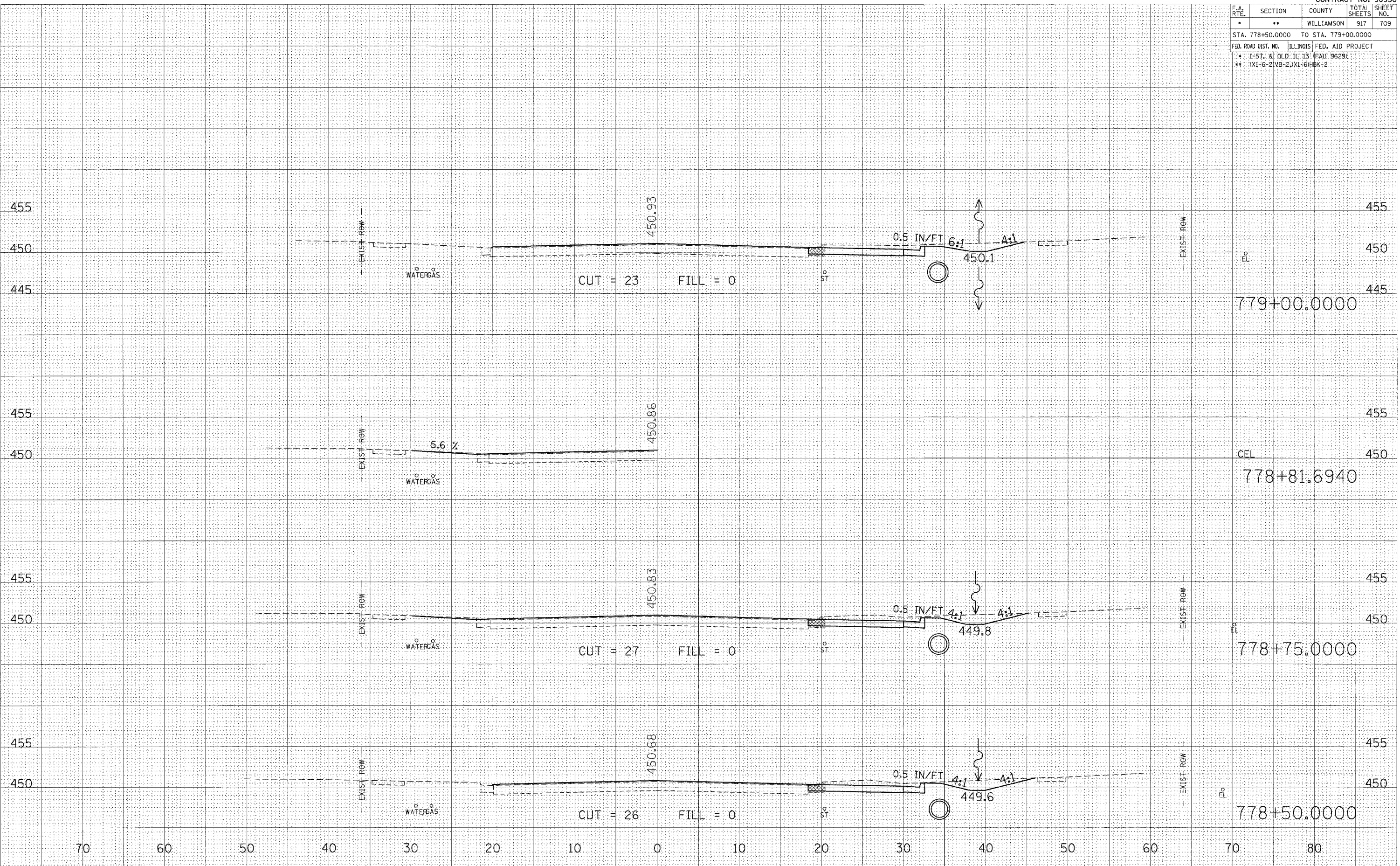

F.A. RTE.	SECTION	COUNTY	TOTAL SHEETS	SHEET NO.
*	**	WILLIAMSON	917	710
STA. 779+25.0000 TO STA. 780+00.0000				
FED. ROAD DIST. NO. ILLINOIS FED. AID PROJECT				
* I-57 & OLD IL 13 (FAJ 9629)				
** (X1-6-2)VB-2;(X1-6)HBK-2				

BY _____ DATE _____

SURVEYED	PLOTTED
NOTE BOOK	AREAS CHECKED
NO. _____	

BY _____ DATE _____

ORIGINAL SURVEYED	PLOTTED
NO. _____	AREAS CHECKED

PLOT DATE = 10/26/2006
 FILE NAME = 13020620061026\1302062006.dwg
 PLOT SCALE = 5/8" = 1' IN.
 USER NAME = lavenderba

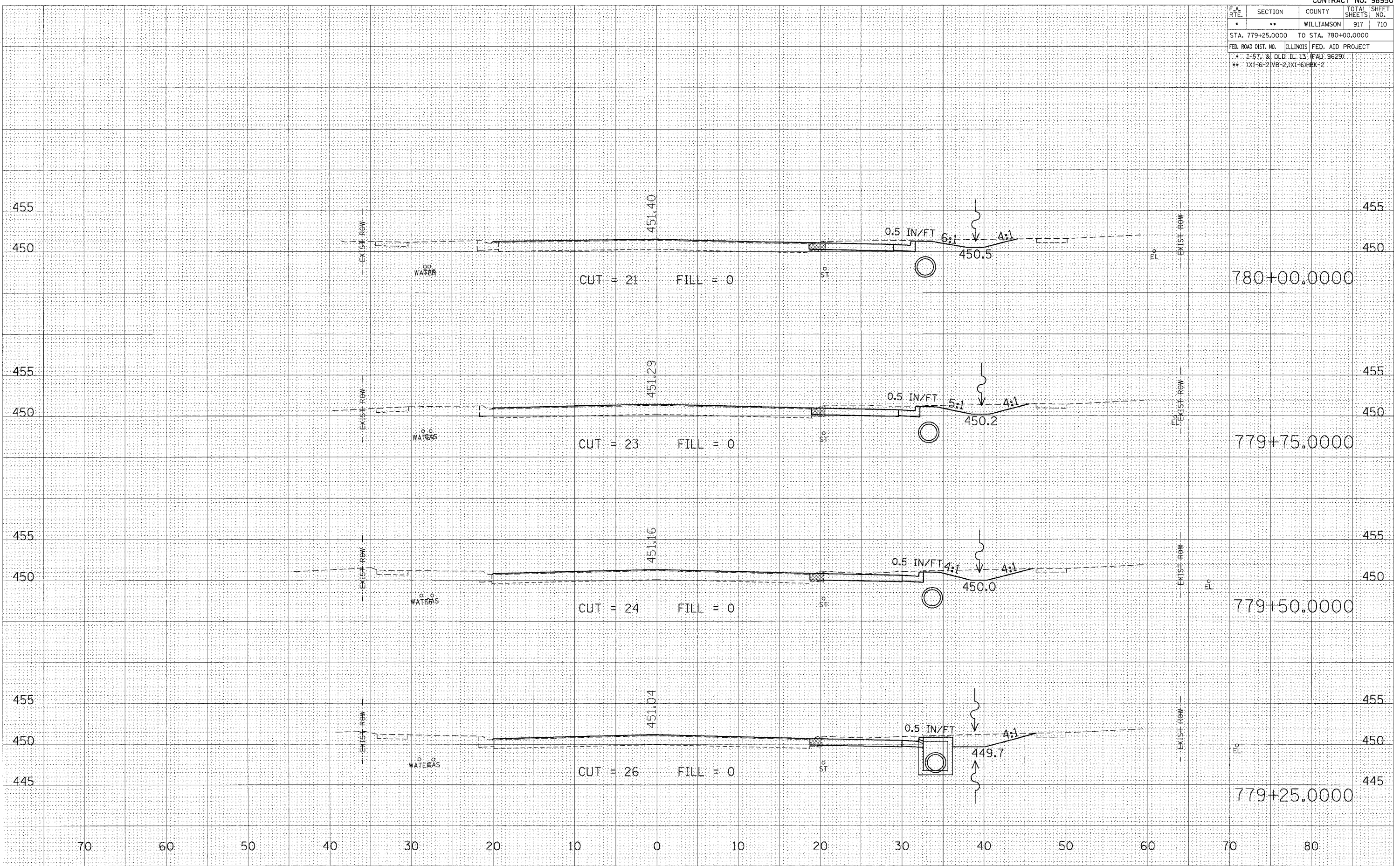

F.A. RTE.	SECTION	COUNTY	TOTAL SHEETS	SHEET NO.
*	**	WILLIAMSON	917	711
STA. 780+25.0000 TO STA. 780+75.0000				
FED. ROAD DIST. NO. ILLINOIS FED. AID PROJECT				
* 1-57. & OLD IL 13 (FAU 9629)				
** X1-6-21VB-2, X1-6HBK-2				

FINAL SURVEY BY DATE
 SURVEYED SURVEY BY DATE
 NOTE BOOK NO. _____
 TEMPLATE NO. _____
 AREAS CHECKED _____

ORIGINAL SURVEY BY DATE
 SURVEYED SURVEY BY DATE
 NOTE BOOK NO. _____
 TEMPLATE NO. _____
 AREAS CHECKED _____

PLOT DATE = 02/25/2005
 FILE NAME = c:\projects\98282\old\3\vol1\dwg\711.dwg
 PLOT SCALE = 5/8"=1' IN.
 USER NAME = lavenderba

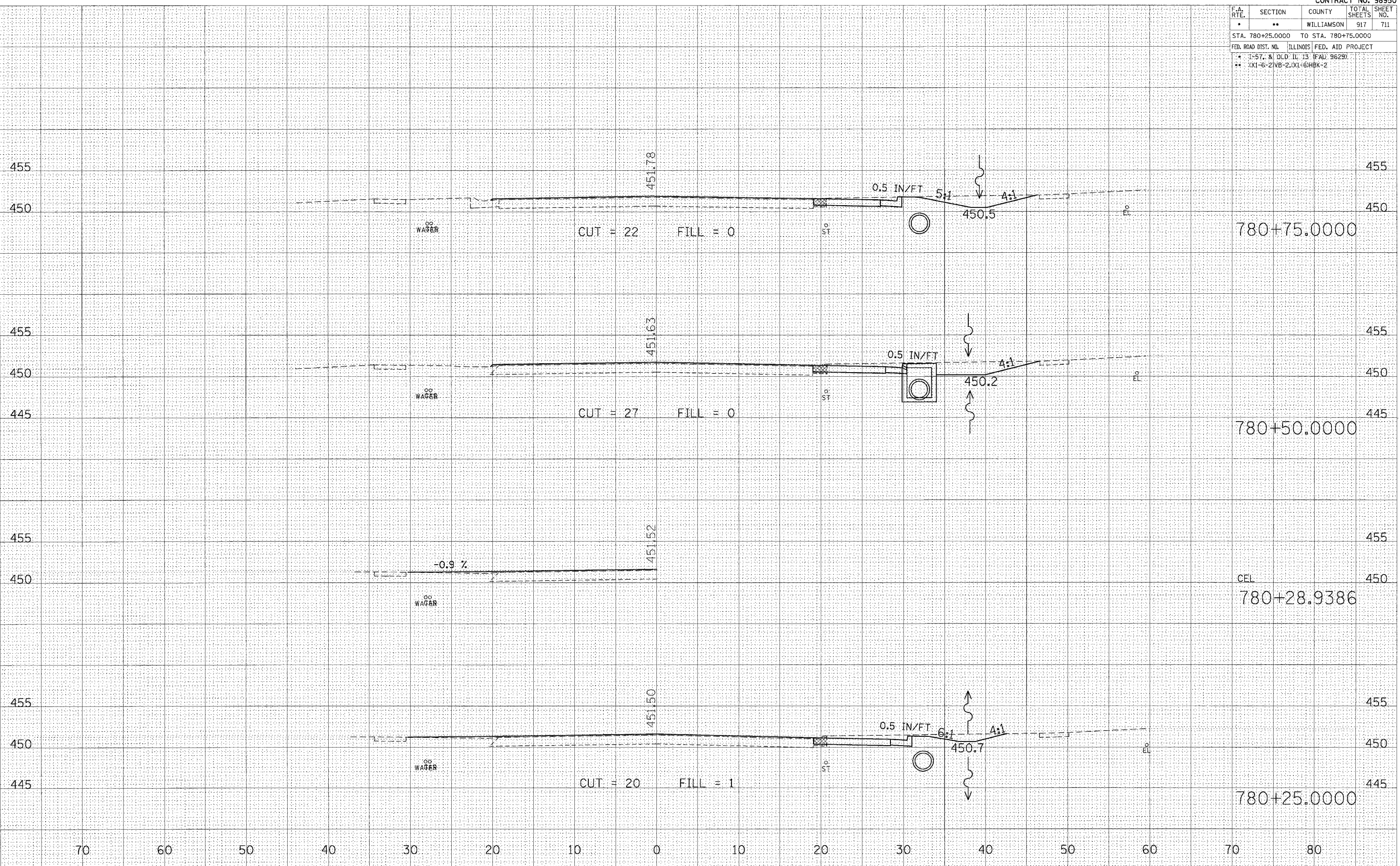

F.A. RTE.	SECTION	COUNTY	TOTAL SHEETS	SHEET NO.
*	**	WILLIAMSON	917	712
STA. 780+97.8038 TO STA. 781+50.0000				
FED. ROAD DIST. NO. ILLINOIS FED. AID PROJECT				
* 1-57, & OLD IL. 13 (FAL 9629)				
** (X1-6-2)VB-2,(X1-6)HBK-2				

DATE	
BY	
FINAL SURVEY	
NOTE BOOK	
AREAS CHECKED	
NO.	

DATE	
BY	
ORIGINAL SURVEY	
NOTE BOOK	
AREAS CHECKED	
NO.	

PLOT DATE = 10/25/2006
 FILE NAME = s:\projects\1418282\old\3\road\1418282.dwg
 PLOT SCALE = 1/8" = 1' IN.
 USER NAME = lavender

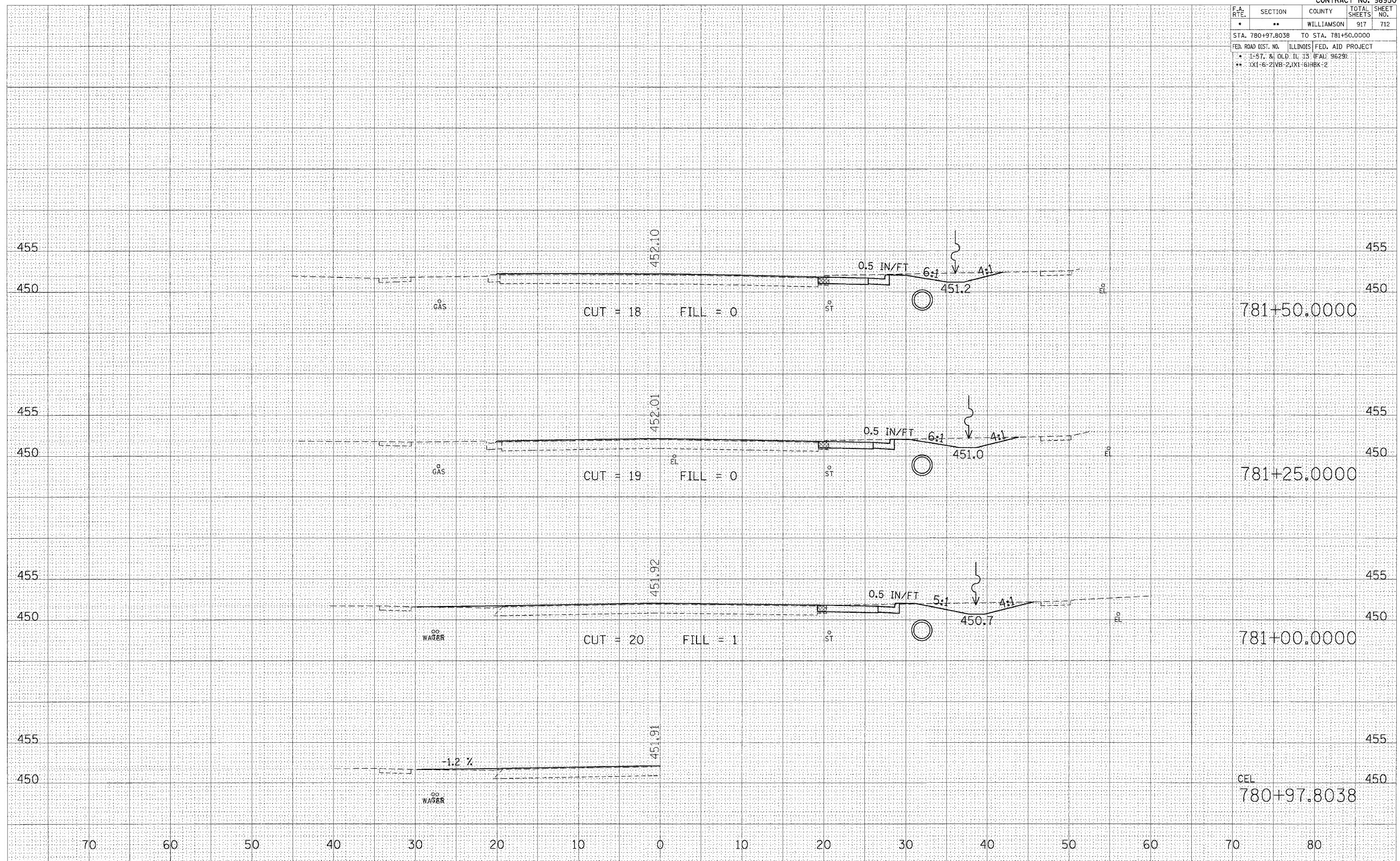

F.A. RTE.	SECTION	COUNTY	TOTAL SHEETS	SHEET NO.
*	**	WILLIAMSON	917	713
STA. 781+75.0000 TO STA. 782+13.5528				
FED. ROAD DIST. NO. ILLINOIS FED. AID PROJECT				
* I-57, 8, OLD IL 13 (FAU 9629)				
** (X1-6-2)WB-2,(X1-6)HBK-2				

BY: _____ DATE: _____

FINAL SURVEY SURVEYED _____
 SURVEY PLOTTED _____
 NOTE BOOK NO. _____
 AREAS CHECKED _____

BY: _____ DATE: _____

ORIGINAL SURVEY SURVEYED _____
 SURVEY PLOTTED _____
 NOTE BOOK NO. _____
 AREAS CHECKED _____

PLOT DATE = 10/25/2006
 PLOT SCALE = 5,000' / IN.
 USER NAME = lloverdm-ba

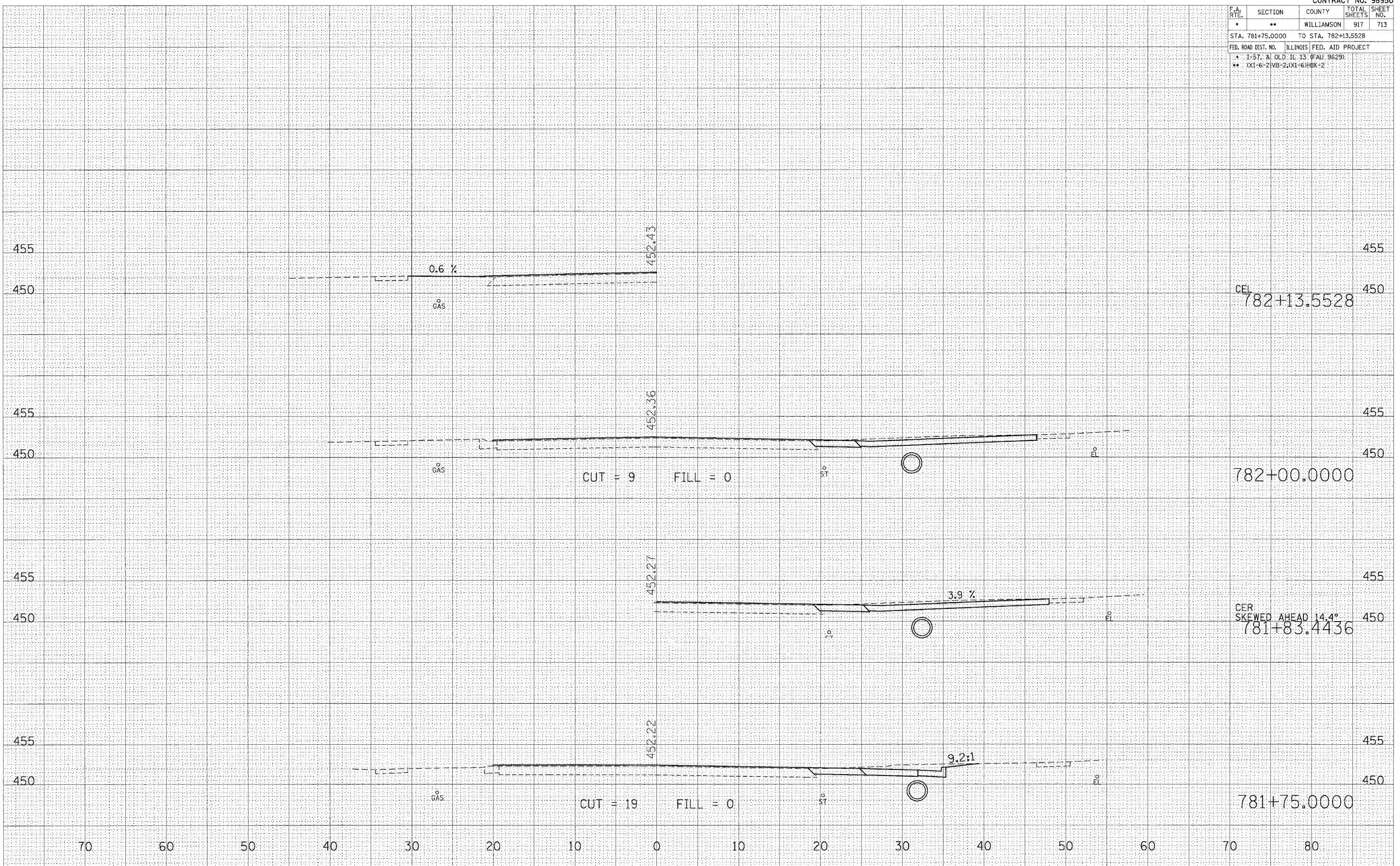

F.A. RTE.	SECTION	COUNTY	TOTAL SHEETS	SHEET NO.
*	**	WILLIAMSON	917	714
STA. 782+25.0000 TO STA. 782+92.9297				
FED. ROAD DIST. NO. ILLINOIS FED. AID PROJECT				
* 1-57, & OLD IL 13 (FAU 9629)				
** IX1-6-21VB-2, IX1-61HBK-2				

FINAL SURVEY BY DATE
 SURVEYED SURVEY BY DATE
 NOTE BOOK NO.
 TEMPLATE AREAS CHECKED

ORIGINAL SURVEY BY DATE
 SURVEYED SURVEY BY DATE
 NOTE BOOK NO.
 TEMPLATE AREAS CHECKED

PLOT DATE = 10/25/2006
 FILE NAME = c:\projects\98950\old13\old13.dwg
 PLOT SCALE = 1/8" = 1'-0"
 USER NAME = lavender

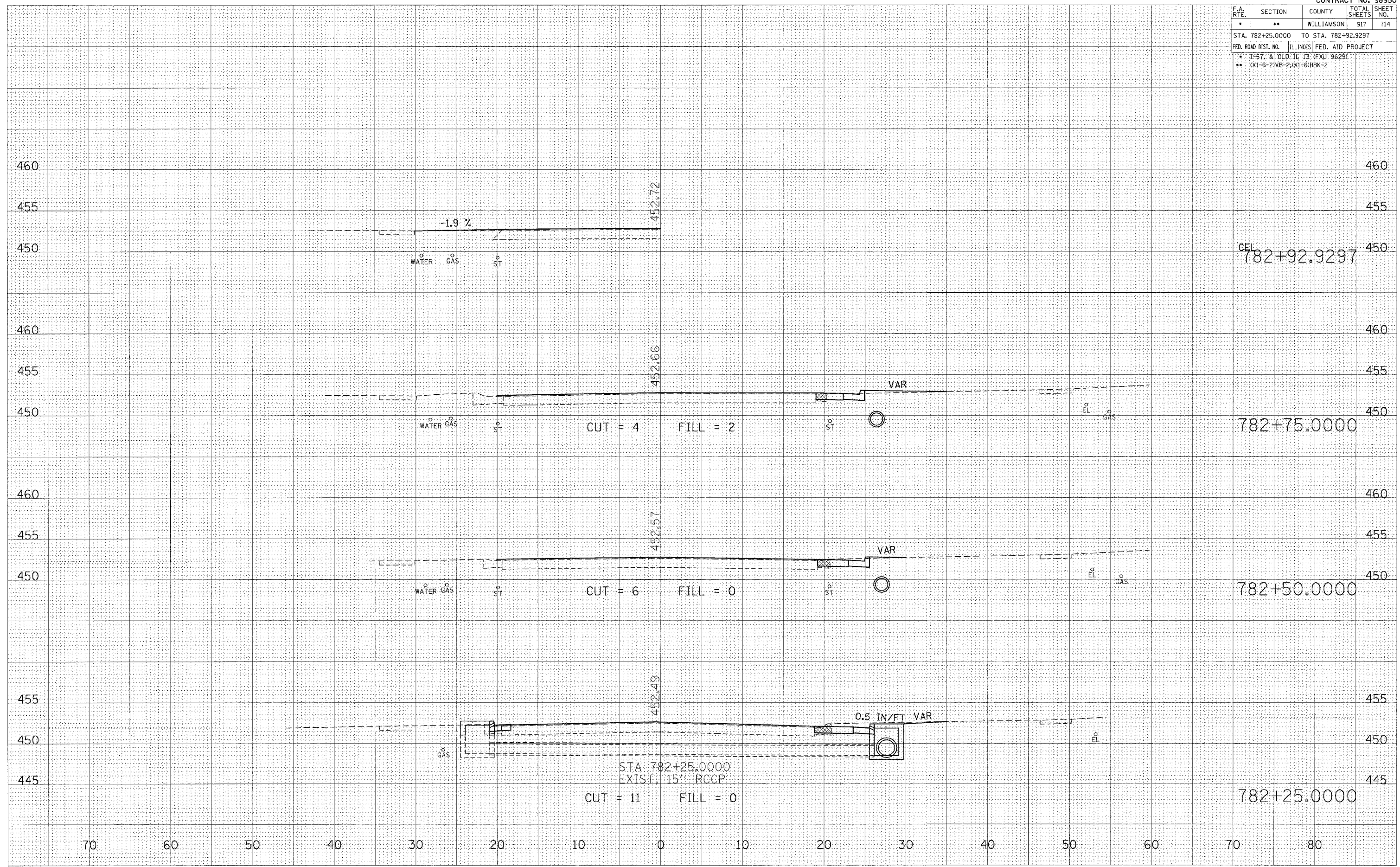

F.A. RTE.	SECTION	COUNTY	TOTAL SHEETS	SHEET NO.
•	**	WILLIAMSON	917	715
STA. 783+00.0000 TO STA. 783+75.0000				
FED. ROAD DIST. NO. ILLINOIS FED. AID PROJECT				
• I-57, & OLD IL 13 (FAJ 9629)				
** (X1-6-2)VB-2,(X1-6)HBK-2				

BY: _____ DATE: _____
 SURVEYED _____
 PLOTTED _____
 CHECKED _____
 AREAS CHECKED _____
 NO. _____

BY: _____ DATE: _____
 SURVEYED _____
 PLOTTED _____
 CHECKED _____
 AREAS CHECKED _____
 NO. _____

PLT DATE = 11/25/2006
 PLT NAME = ...
 PLT SCALE = 5/8" = 1' IN.
 USER NAME = lavenderba

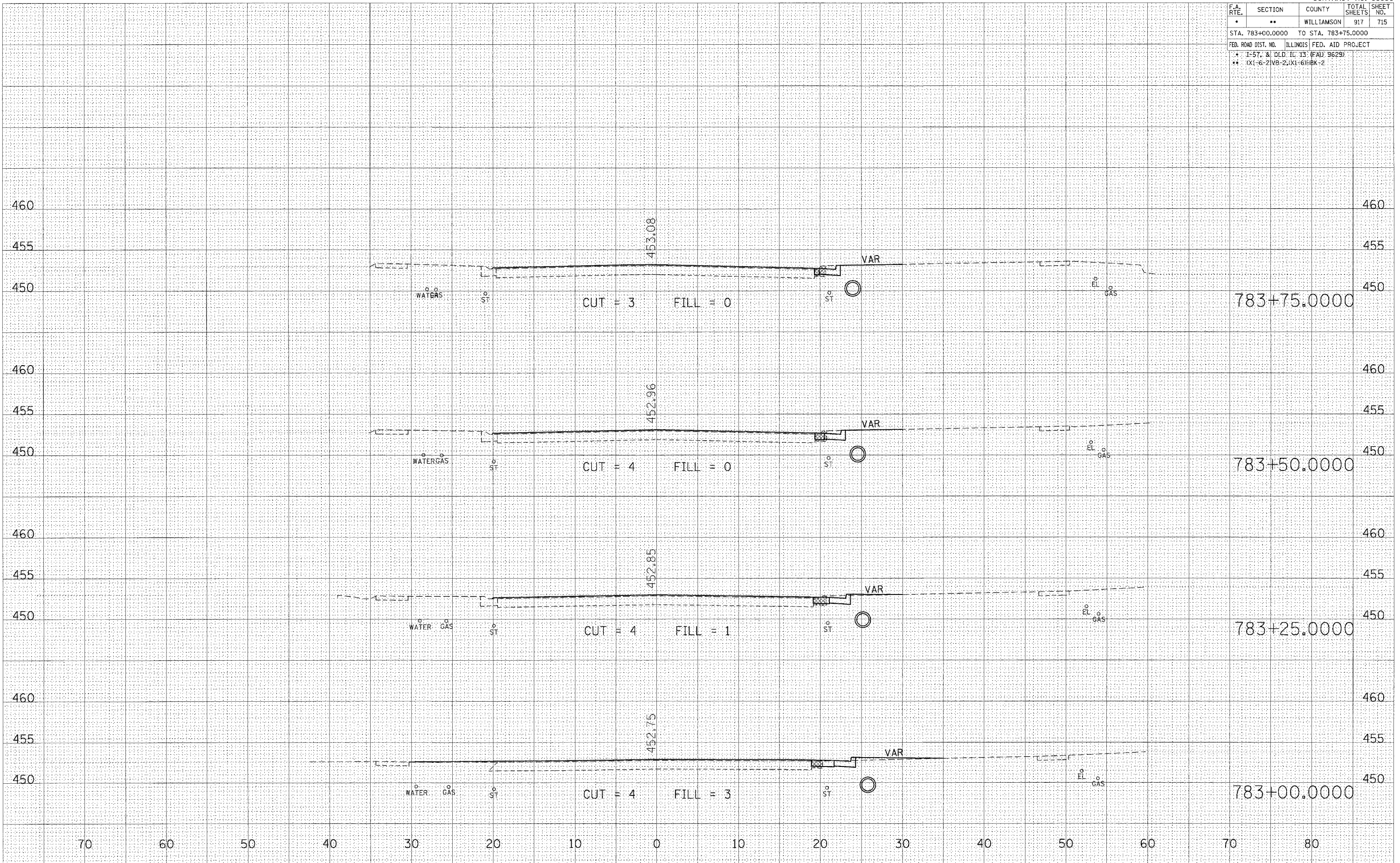

F.A. RTE.	SECTION	COUNTY	TOTAL SHEETS	SHEET NO.
---	---	WILLIAMSON	917	116
STA. 784+00.0000 TO STA. 784+75.0000				
FED. ROAD DIST. NO. [ILLINOIS] FED. AID PROJECT				
* I-57, & OLD IL 13 (FAU: 9629)				
** (X1-6-2)(XB-2)(XI-6)HBK-2				

DATE	
BY	
SURVEYED	
PLOTTED	
NOTE BOOK	
AREAS CHECKED	
NO.	

DATE	
BY	
ORIGINAL	
COPY	
AREAS CHECKED	
NO.	

PLOT DATE = 11/27/2006
 FILE NAME = \\s0228282\old13\road\98950\116.dwg
 PLOT SCALE = 5/8" = 1' / 31.68'
 USER NAME = jef@hohai

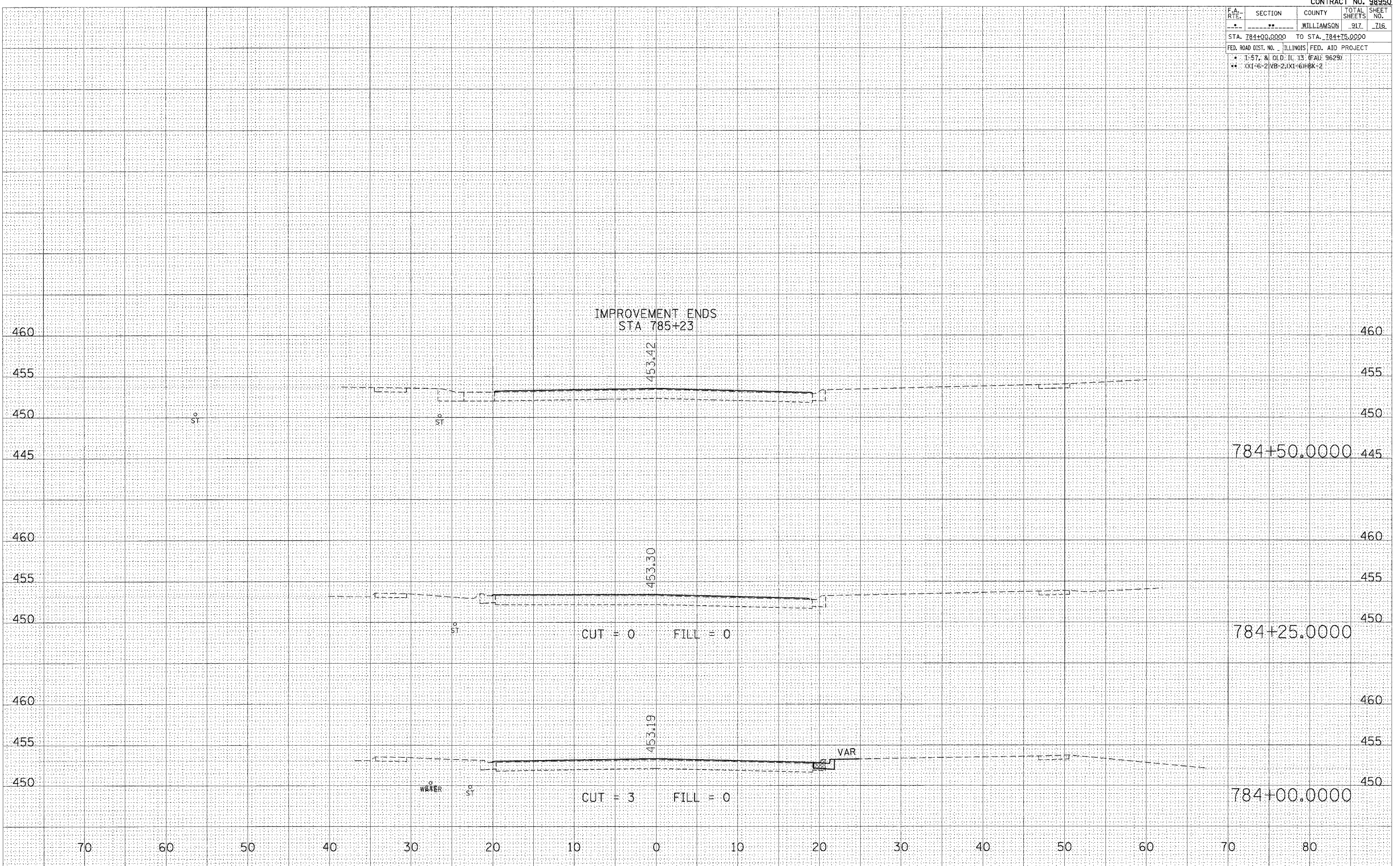

CONTRACT NO. 98950				
F.A. RTE.	SECTION	COUNTY	TOTAL SHEETS	SHEET NO.
**	**	WILLIAMSON	917	717
STA.	TO STA.			
FED. ROAD DIST. NO. ILLINOIS FED. AID PROJECT				
* I-57, & OLD IL 13 (FAU 9629)				
** (X1-6-2)VB-2,(X1-6)HBK-2				

PLAN	SURVEYED	DATE
	BY	
	DATE	
NOTE BOOK	NO.	
RT. OF WAY CHECKED		
PAID FILE NAME		

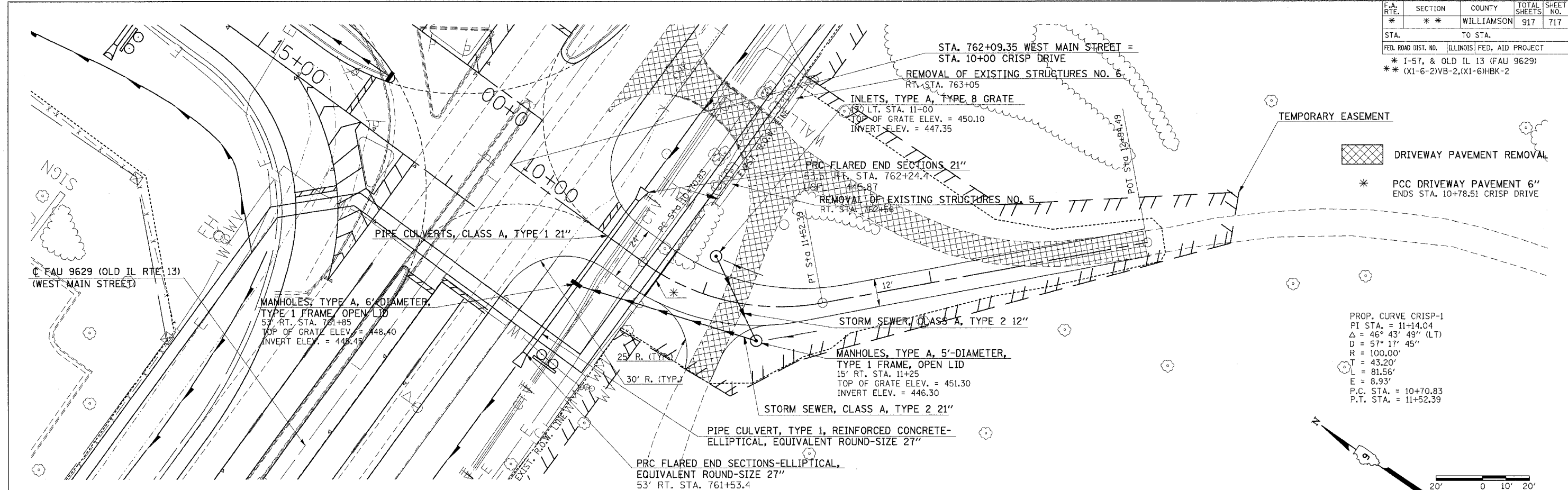

TEMPORARY EASEMENT

DRIVEWAY PAVEMENT REMOVAL

* PCC DRIVEWAY PAVEMENT 6" ENDS STA. 10+78.51 CRISP DRIVE

PROP. CURVE CRISP-1
 PI STA. = 11+14.04
 $\Delta = 46^\circ 43' 49"$ (LT)
 $D = 57' 17" 45"$
 $R = 100.00'$
 $T = 43.20'$
 $L = 81.56'$
 $E = 8.93'$
 P.C. STA. = 10+70.83
 P.T. STA. = 11+52.39

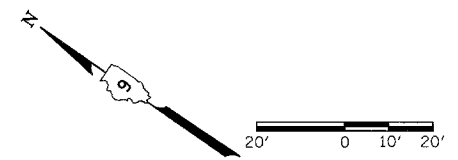

PROFILE	SURVEYED	DATE
	BY	
	DATE	
NOTE BOOK	NO.	
STRUCTURE NOTATIONS CRTD		

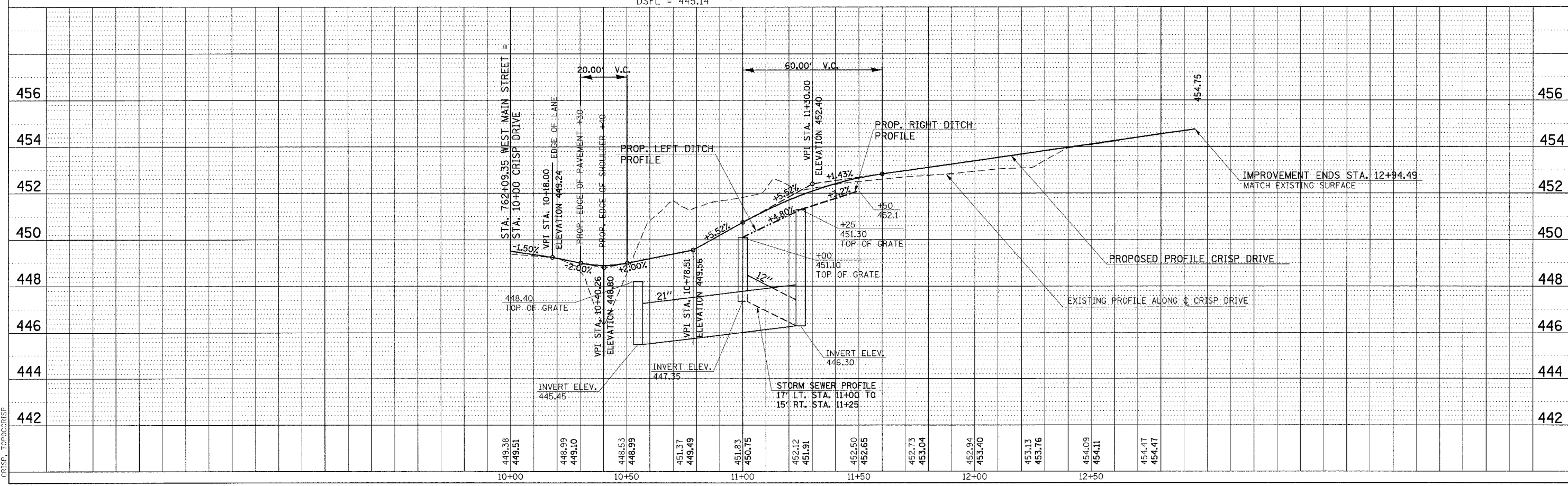

PLT DATE = 12/6/2006
 FILE NAME = C:\Users\mva\OneDrive\Projects\982802\1013\1013crisp.dgn
 PLOT SCALE = 20.00000 / IN.
 USER NAME = hbeiden
 CRISP_TOPOCRISP

PLAN - PROFILE STA. 10+00 TO STA. 12+94.49 CRISP DRIVE

F.A. RTE.	SECTION	COUNTY	TOTAL SHEETS	SHEET NO.
*	*	WILLIAMSON	917	718
STA.		TO STA.		
FED. ROAD DIST. NO.		ILLINOIS FED. AID PROJECT		
* I-57, & OLD IL 13 (FAU 9629)				
** (X1-6-2)VB-2,(X1-6)HBK-2				

NOTE: SEE SEPARATE EROSION CONTROL SHEETS FOR RAMPS AND OLD IL 13

PROP. CURVE CRISP-1
 PI STA. = 11+14.04
 $\Delta = 46^\circ 43' 49''$ (LT)
 $D = 57' 17' 45''$
 $R = 100.00'$
 $T = 43.20'$
 $L = 81.56'$
 $E = 8.93'$
 P.C. STA. = 10+70.83
 P.T. STA. = 11+52.39

PLAN	DATE
BY	
DATE	
BY	
DATE	
BY	
DATE	
BY	
DATE	

PROFILE	DATE
BY	
DATE	
BY	
DATE	
BY	
DATE	
BY	
DATE	

PLOT DATE = 12/16/2006
 FILE NAME = c:\pccrisp\15\d302802\vol1\d302802.dgn
 PLOT SCALE = 20.0000 / IN
 USER NAME = headon
 CRISP, TPOCCRISP

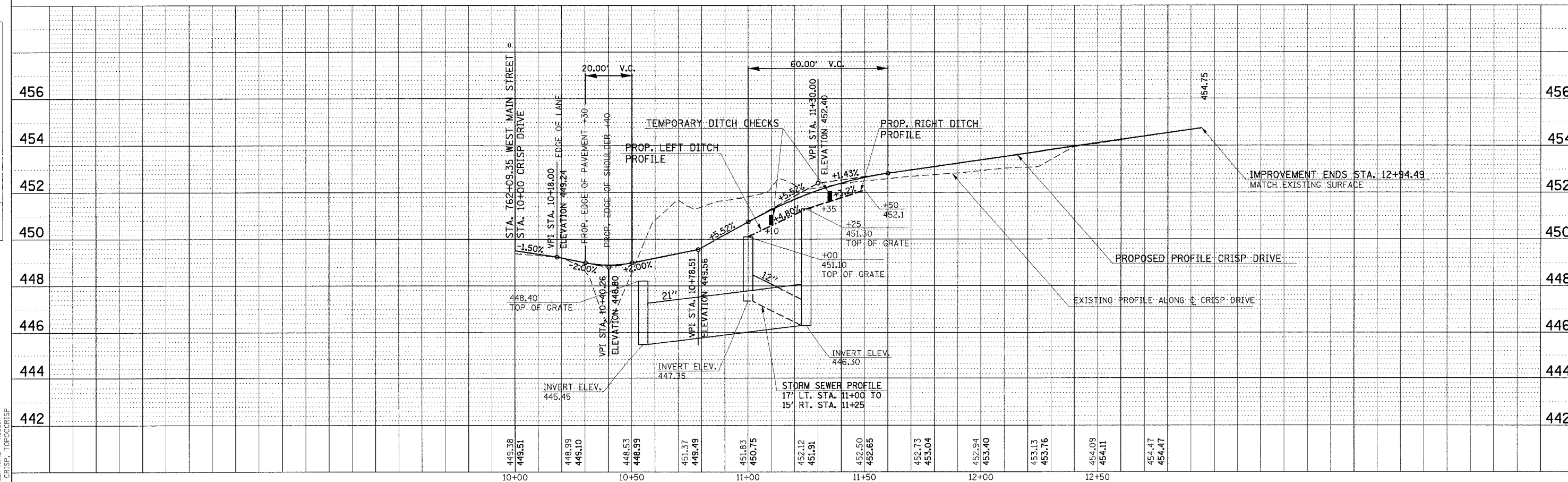
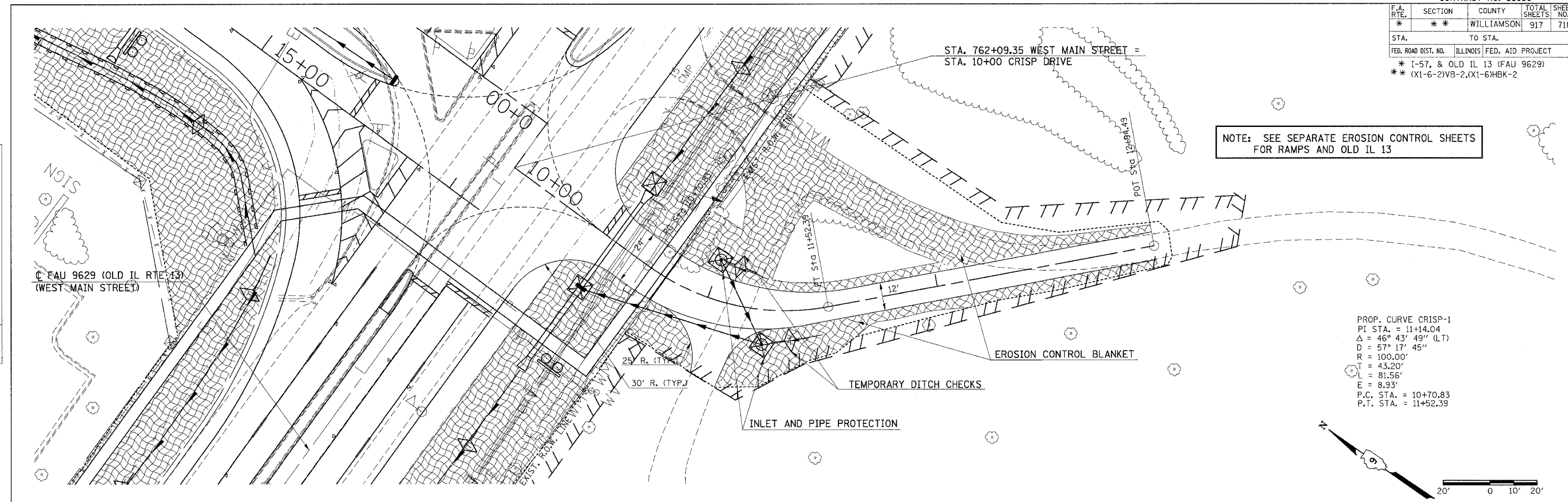

EROSION CONTROL STA. 10+00 TO STA. 12+94.49 CRISP DRIVE

F.A. RTE.	SECTION	COUNTY	TOTAL SHEETS	SHEET NO.
*	**	WILLIAMSON	917	719
STA. 10+50.0000 TO STA. 11+07.0875				
FED. ROAD DIST. NO. ILLINOIS FED. AID PROJECT				
* I-57, & OLD IL 13 (FAD 9629)				
** (X1-6-2)VB-2,(X1-6)HBK-2				

DATE _____
BY _____
REVISIONS
SURVEY PLOTTED
TEMPLATE AREAS CHECKED
FINAL SURVEY NOTE BOOK NO. _____

DATE _____
BY _____
ORIGINAL SURVEY
SURVEY PLOTTED
TEMPLATE AREAS CHECKED
FINAL SURVEY NOTE BOOK NO. _____

DATE = 11/17/2006
FILE NAME = c:\proworks\1022882\old13\zcrisp.dwg
PLOT SCALE = 5/8000 / IN.
USER NAME = TerPuchol

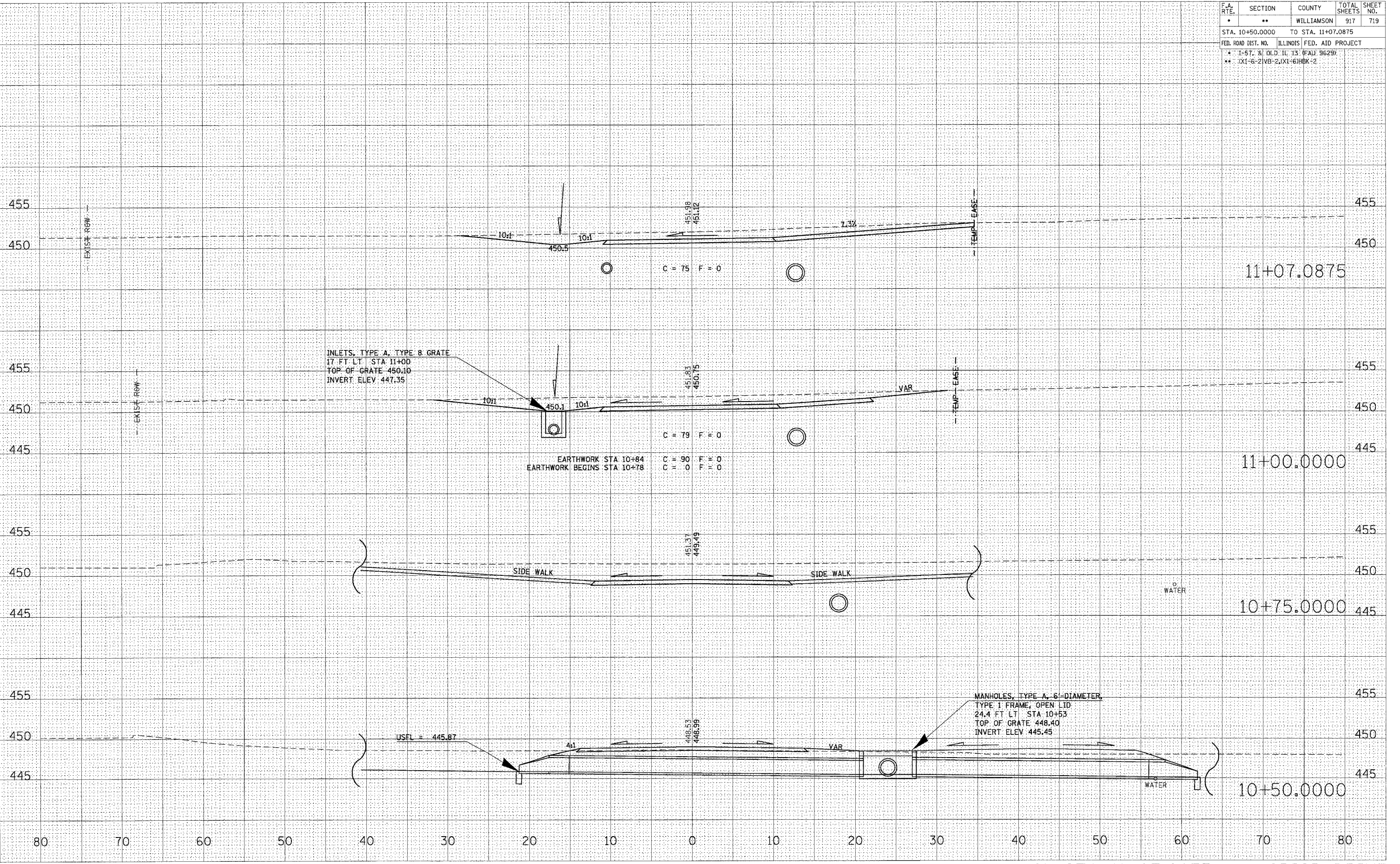

STA 10+50.0000 TO STA 11+07.0875 CRISP DRIVE

F.A. RTE.	SECTION	COUNTY	TOTAL SHEETS	SHEET NO.
*	**	WILLIAMSON	917	720
STA. 11+25.0000		TO STA. 12+25.0000		
FED. ROAD DIST. NO.		ILLINOIS FED. AID PROJECT		
* 1-57, 8 OLD. IL. 13 (FAJ 9625)				
** 0X1-6-21V8-2, 0X1-61H8K-2				

DATE	
BY	
FINAL SURVEY	
NOTE BOOK	
TEMPLATE	
AREAS	
AREAS CHECKED	
NO.	

DATE	
BY	
ORIGINAL SURVEY	
TEMPLATE	
AREAS	
AREAS CHECKED	
NO.	

PLOT DATE = 11/17/2006
 FILE NAME = c:\projects\98950\1125\crisp.dwg
 PLOT SCALE = 1/8" = 1'-0"
 USER NAME = jef@ch2m

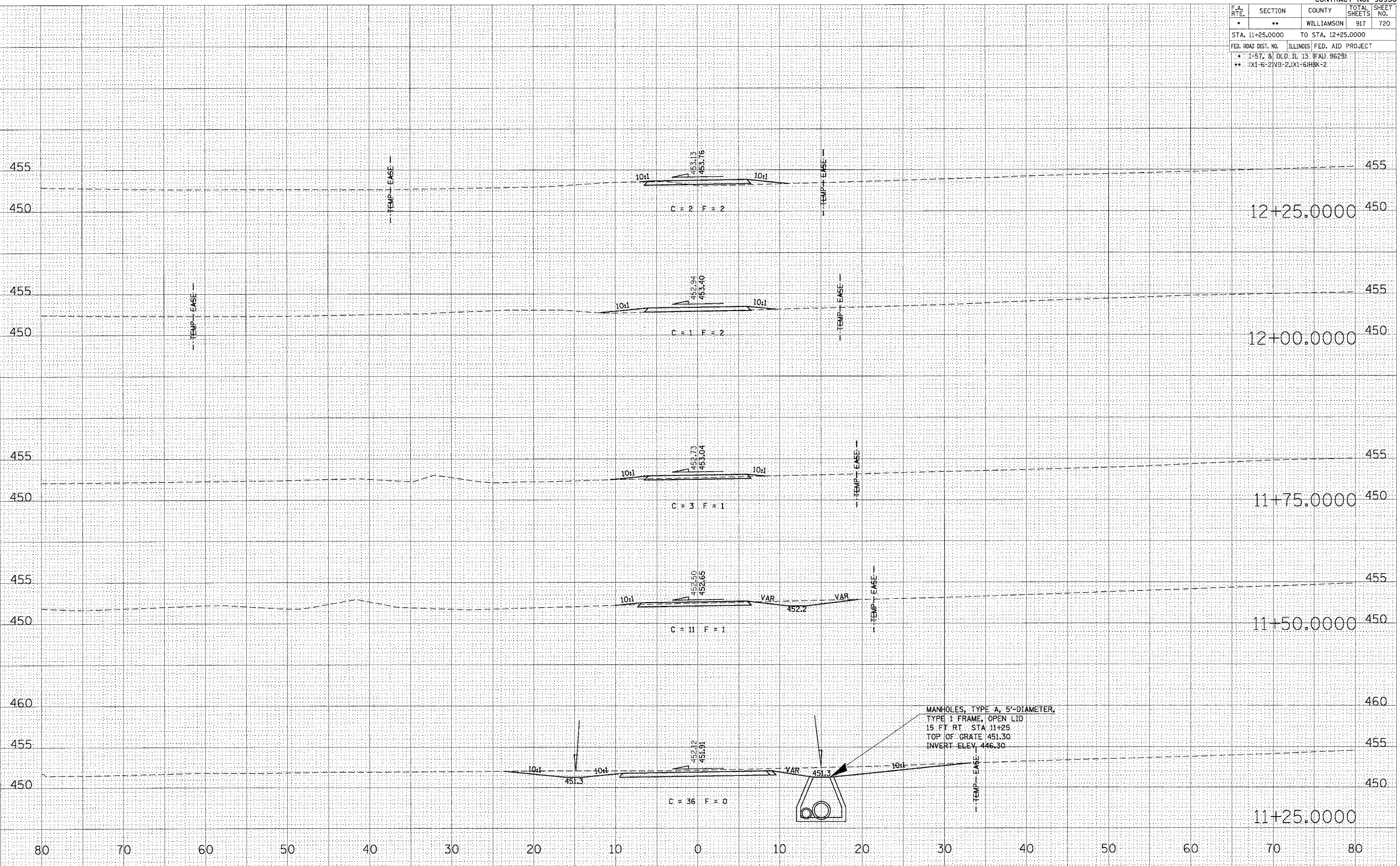

STA 11+25.0000 TO STA 12+25.0000 CRISP DRIVE

MANHOLES, TYPE A, 5'-DIAMETER,
 TYPE 1 FRAME, OPEN LID
 15 FT. RT. STA 11+25
 TOP OF GRATE 451.30
 INVERT ELEV. 446.30

F.A. RTE.	SECTION	COUNTY	TOTAL SHEETS	SHEET NO.
*	**	WILLIAMSON	917	721
STA. 12+50.0000		TO STA. 12+75.0000		
FED. ROAD DIST. NO.		ILLINOIS FED. AID PROJECT		
* 1-57, & OLD. IL. 13 (FAU 9629)		** (X1-6-2) (VB-2) (X1-6) (HBK-2)		

DATE	BY
FINAL SURVEY	
NOTE BOOK	
NO.	
SURVEYED	
TEMPLATE	
AREAS CHECKED	

DATE	BY
ORIGINAL SURVEY	
NOTE BOOK	
NO.	
SURVEYED	
TEMPLATE	
AREAS CHECKED	

PLOT DATE = 11/17/2006
FILE NAME = c:\projects\p12282\old\9\zcris1\p12282.dwg
PLOT SCALE = 1/8" = 100'
USER NAME = left\chd

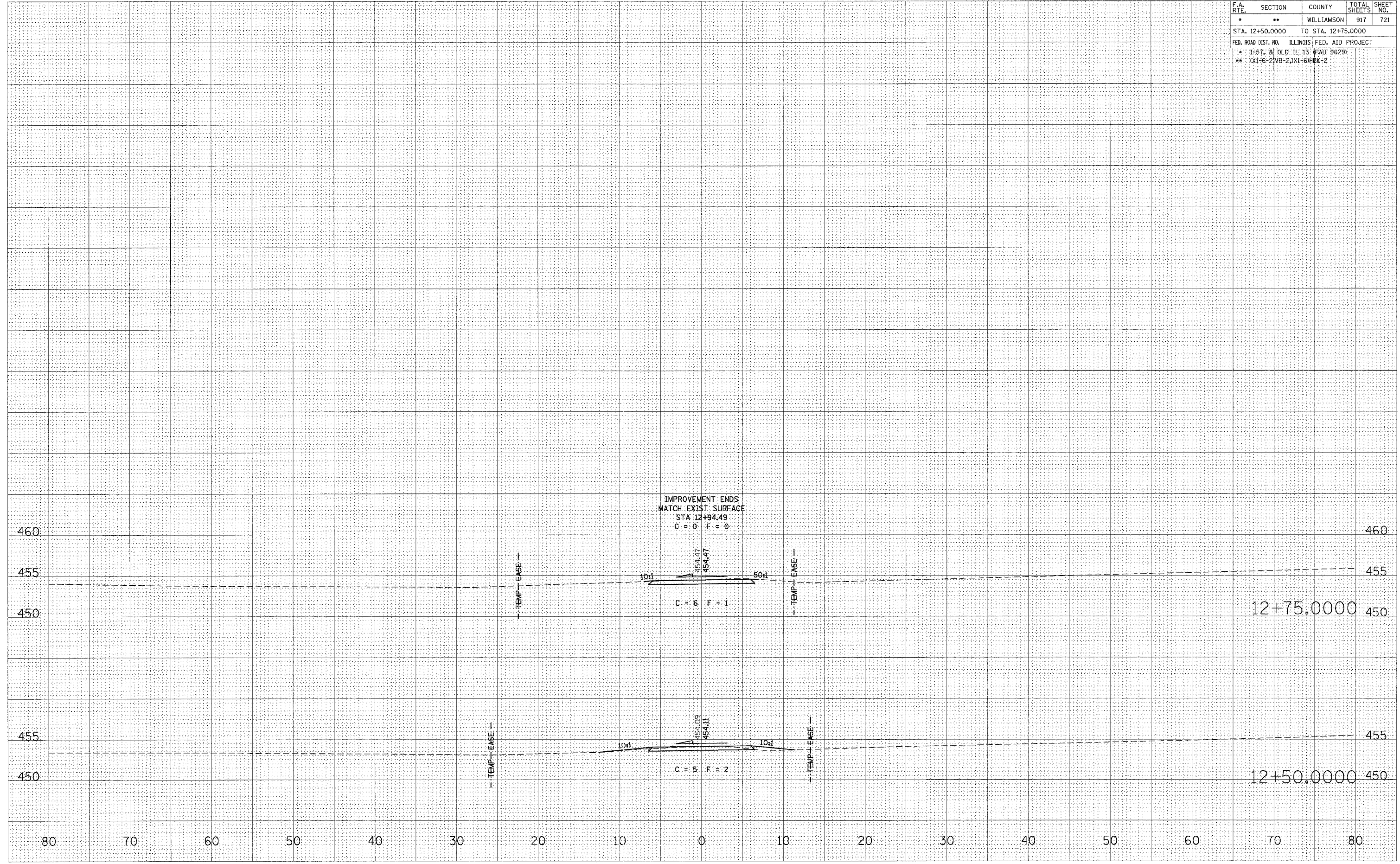

STA 12+50.0000 TO STA 12+75.0000 CRISP DRIVE

CONTRACT NO. 98950				
F.A. RTE.	SECTION	COUNTY	TOTAL SHEETS	SHEET NO.
*	*	WILLIAMSON	917	722
STA. TO STA.				
FED. ROAD DIST. NO. ILLINOIS FED. AID PROJECT				
* I-57, & OLD IL 13 (FAU 9629)				
** (X1-6-2)VB-2,(X1-6)HBK-2				

DATE	
BY	
PLAN	
DATE	
BY	
PLAN	
DATE	
BY	
PLAN	

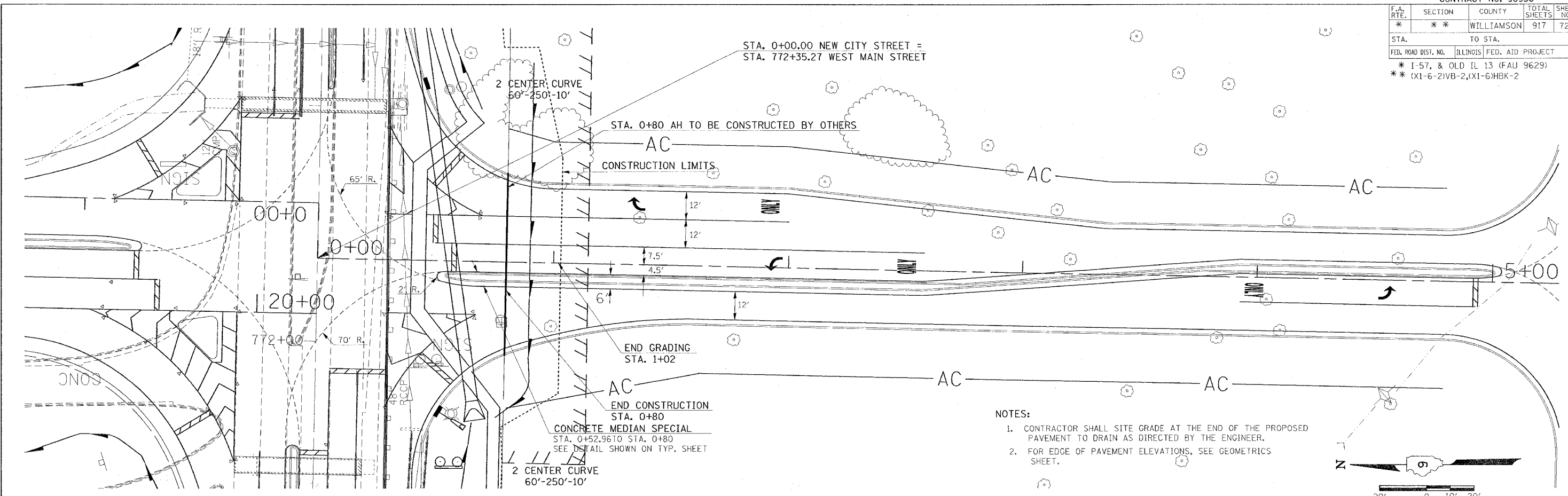

- NOTES:
1. CONTRACTOR SHALL SITE GRADE AT THE END OF THE PROPOSED PAVEMENT TO DRAIN AS DIRECTED BY THE ENGINEER.
 2. FOR EDGE OF PAVEMENT ELEVATIONS, SEE GEOMETRICS SHEET.



DATE	
BY	
PROFILE	
DATE	
BY	
PROFILE	

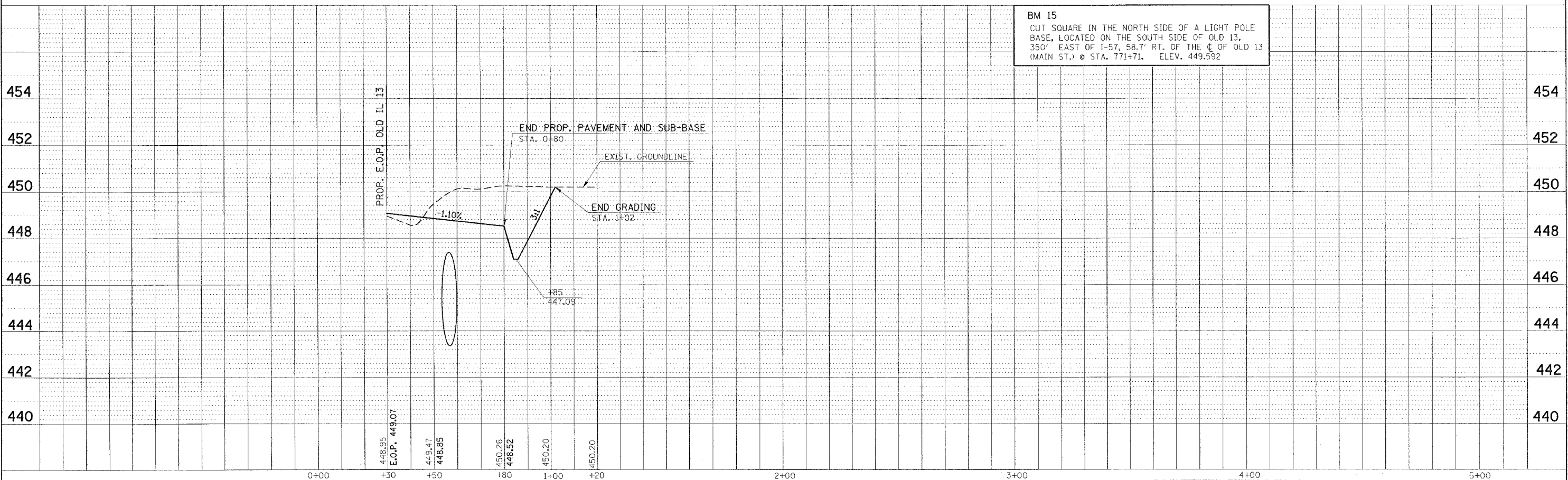

PLOT DATE = 11/17/2006
 FILE NAME = c:\pfs\mets\080202\old13\old13p2.dgn
 PLOT SCALE = 20/0000 / IN.
 USER NAME = feason

PLAN - PROFILE STA. 0+00.00 TO STA. 5+25.00 NEW CITY STREET

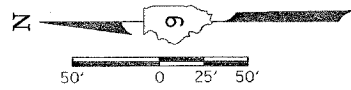

PROP. CURVE RAMP-E-3
 PI STA. = 13+75.19
 $\Delta = 10^\circ 29' 08''$ (RT)
 $D = 7^\circ 29' 23''$
 $R = 765.00'$
 $T = 70.20'$
 $L = 140.00'$
 $E = 3.21'$
 $e = 8\%$
 P.C. STA = 13+04.99
 P.T. STA = 14+44.99

CONTRACT NO. 98950				
F.A. RTE.	SECTION	COUNTY	TOTAL SHEETS	SHEET NO.
*	**	WILLIAMSON	917	723
STA. TO STA.				
ILLINOIS FED. AID PROJECT				
* I-57, & OLD IL 13 (FAU 9629)				
** (X1-6-2)VB-2, (X1-6)HBK-2				

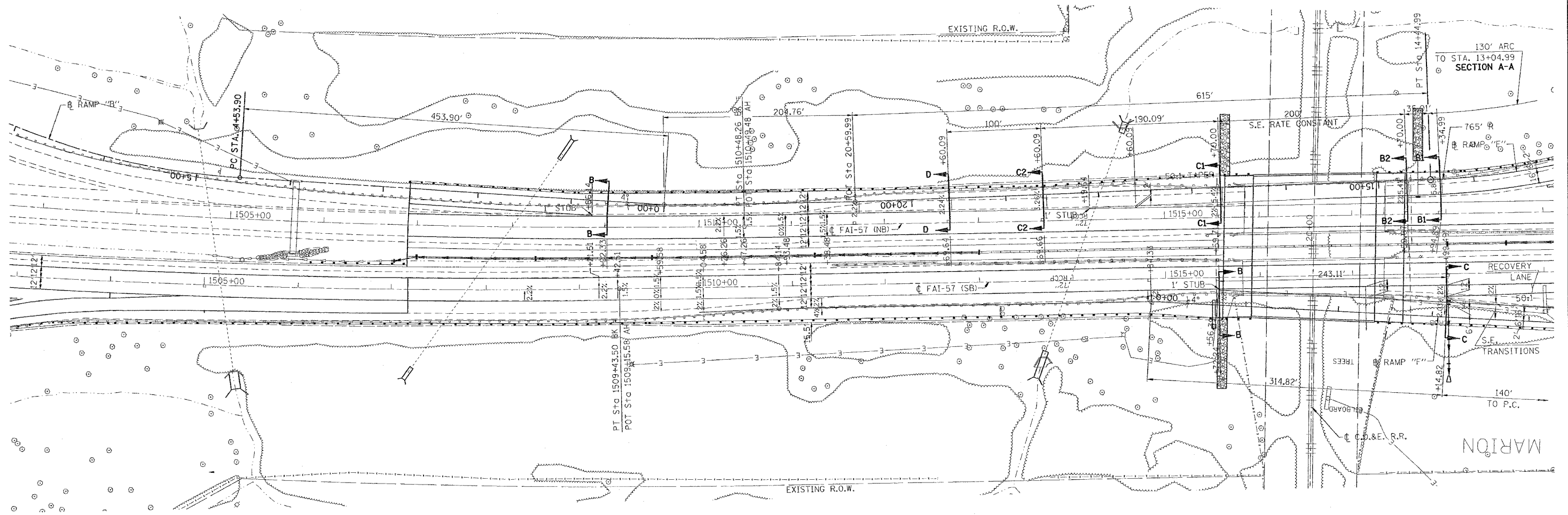

NOTE:
 EXISTING RAMP PAVEMENT AND SHOULDER SLOPES TRANSITION TO PROPOSED SLOPES FROM RT. STA. 1507+18 TO STA. 1508+25 (SBL).

PLOT DATE = 10/24/2008
 FILE NAME = c:\pwork\98950\p082802\c0d13\o13136.dgn
 PLOT SCALE = 30.0000 / IN.
 USER NAME = hedger

REVISIONS	
NAME	DATE

ILLINOIS DEPARTMENT OF TRANSPORTATION

**I-57
 GEOMETRICS**
 STA. 1503+00 TO STA. 1519+00

SCALE: VERT. 50
 HORIZ. 1"=100'
 DATE _____

DRAWN BY CNH
 CHECKED BY _____

F.A. RTE.	SECTION	COUNTY	TOTAL SHEETS	SHEET NO.
*	**	WILLIAMSON	917	724
STA. TO STA.				
FED. ROAD DIST. NO. ILLINOIS FED. AID PROJECT				
* I-57, & OLD IL 13 (FAU 9629)				
** (X1-6-2)VB-2, (X1-6)HBK-2				

CURVE DATA RAMP E-1
 PI STA. = 5+92.93
 $\Delta = 58^\circ 16' 56''$ (LT)
 $D = 19^\circ 05' 55''$
 $R = 300.00'$
 $T = 167.26'$
 $L = 305.16'$
 $E = 43.48'$
 $e = 8\%$
 $T.R. = 35'$
 $S.E. RUN = 195$
 $P.C. STA. = 4+25.67$
 $P.T. STA. = 7+30.83$
ATTAIN S.E.:
 STA. 0+34.00 (-0.5%) TO
 STA. 2+00.00 (-1.5%) TO
 STA. 2+59.67 (-1.5%) TO
 STA. 4+89.67 (8%)
REMOVE S.E.:
 STA. 6+38.00 (8%) TO
 STA. 8+68.00 (-1.5%)

CURVE DATA RAMP E-3
 PI STA. = 13+75.19
 $\Delta = 10^\circ 29' 08''$ (RT)
 $D = 7^\circ 29' 23''$
 $R = 765.00'$
 $T = 70.20'$
 $L = 140.00'$
 $E = 3.21'$
 $e = 8\%$
 $T.R. = N/A$
 $S.E. RUN = N/A$
 $P.C. STA. = 13+04.99$
 $P.T. STA. = 14+44.99$
REMOVE S.E.:
 (THROUGH ENTRANCE TERMINAL W/AUX. LANE)
 STA. 13+04.99 (-8%) TO STA. 14+34.99 (-5.81%)
 STA. 14+34.99 (-5.81%) TO STA. 14+70.00 (-5.4%)
 STA. 14+70.00 (-5.4%) TO STA. 16+70.00 (-5.4%)
 STA. 16+70.00 (-5.4%) TO STA. 18+60.09 (-3.26%)
 STA. 18+60.09 (-3.26%) TO STA. 19+60.09 (-2.24%)

CURVE DATA RAMP E-2
 PI STA. = 11+33.63
 $\Delta = 44^\circ 37' 57''$ (RT)
 $D = 12^\circ 19' 18''$
 $R = 465.00'$
 $T = 190.86'$
 $L = 362.23'$
 $E = 37.65'$
 $e = 8\%$
 $T.R. = 40'$
 $S.E. RUN = 220'$
 $P.C. STA. = 9+42.77$
 $P.T. STA. = 13+04.99$
ATTAIN S.E.:
 STA. 8+68.00 (-1.5%) TO
 STA. 10+48.00 (-8%)

CURVE DATA RAMP EE-2
 PI STA. = 28+58.53
 $\Delta = 166^\circ 49' 31''$ (RT)
 $D = 26^\circ 09' 45''$
 $R = 219.00'$
 $T = 1,896.41'$
 $L = 637.65'$
 $E = 1,690.01'$
 $e = 8\%$
 $T.R. = 35'$
 $S.E. RUN = 185'$
 $P.C. STA. = 9+62.12$
 $P.T. STA. = 15+99.77$
REMOVE S.E.:
 STA. 15+37.77 (-8%) TO
 STA. 16+87.77 (-1.5%) TO
 STA. 17+50.00 (-1.5%) TO
 STA. 19+91.43 (0.5%)

CURVE DATA RAMP EE-1
 PI STA. = 8+81.41
 $\Delta = 12^\circ 08' 09''$ (RT)
 $D = 7^\circ 29' 23''$
 $R = 765.00'$
 $T = 81.32'$
 $L = 162.03'$
 $E = 4.31'$
 $e = 8\%$
 $T.R. = N/A$
 $S.E. RUN = N/A$
 $P.C. STA. = 8+00.09$
 $P.T. STA. = 9+62.12$
ATTAIN S.E.:
 (THROUGH STANDARD EXIT TERMINAL)
 STA. 6+60.09 (-2%) TO
 STA. 8+70.09 (-8%)

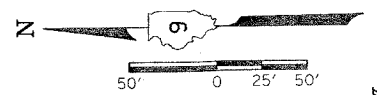
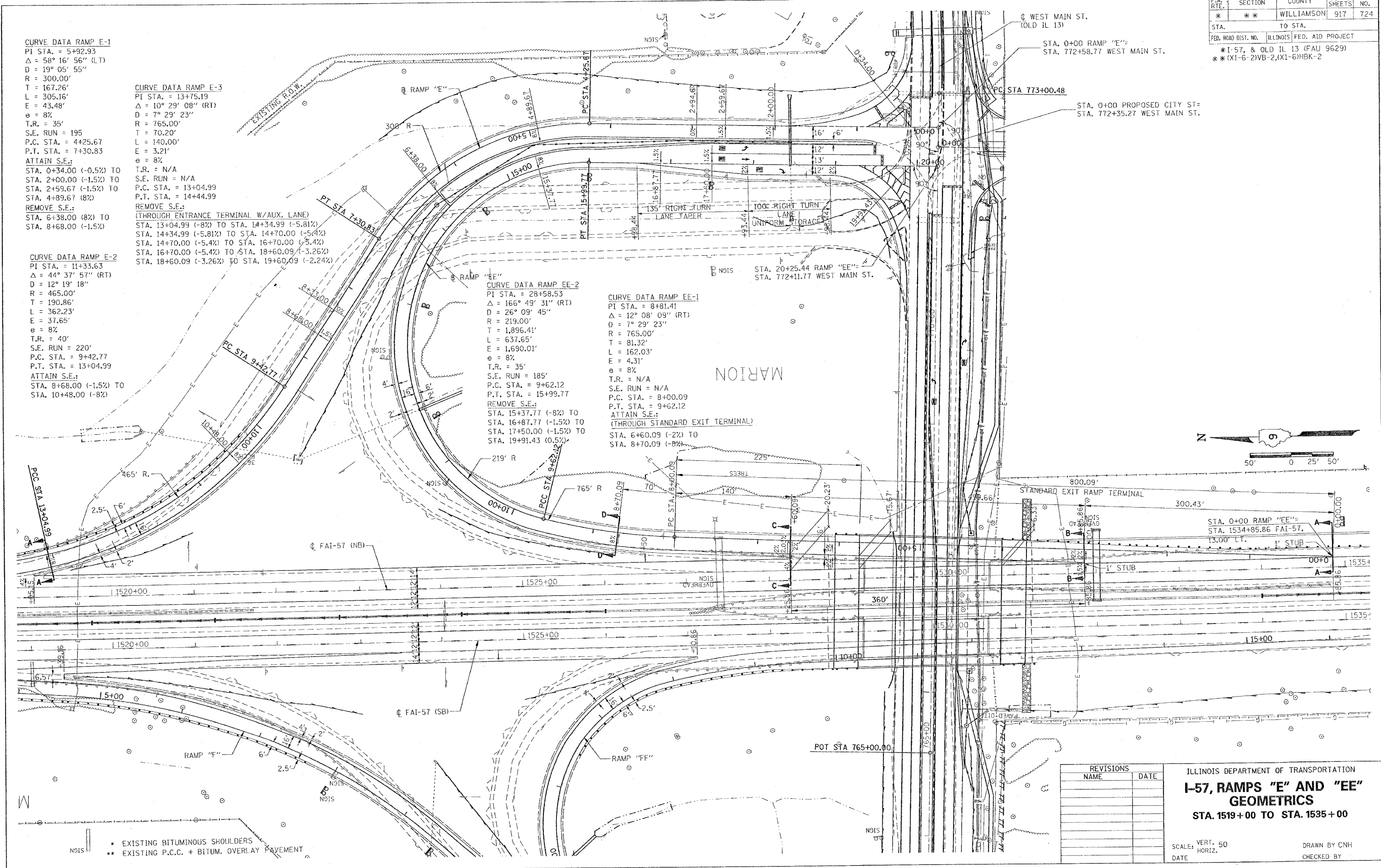

REVISIONS	
NAME	DATE

ILLINOIS DEPARTMENT OF TRANSPORTATION
I-57, RAMPS "E" AND "EE"
GEOMETRICS
 STA. 1519+00 TO STA. 1535+00

SCALE: VERT. 50
 DATE: HORIZ.
 DRAWN BY CNH
 CHECKED BY

PLOT DATE = 10/24/2006
 FILE NAME = c:\pno\mto\98950\2002\0113\vol1\136.dgn
 PLOT SCALE = 5/8"=1'-0"
 USER NAME = Fredson

F.A. RTE.	SECTION	COUNTY	TOTAL SHEETS	SHEET NO.
**	**	WILLIAMSON	917	725
STA. TO STA.				
FED. ROAD DIST. NO.		ILLINOIS FED. AID PROJECT		
		* I-57, & OLD IL 13 (FAU 9629)		
		** (X1-6-2)VB-2, (X1-6)HBK-2		

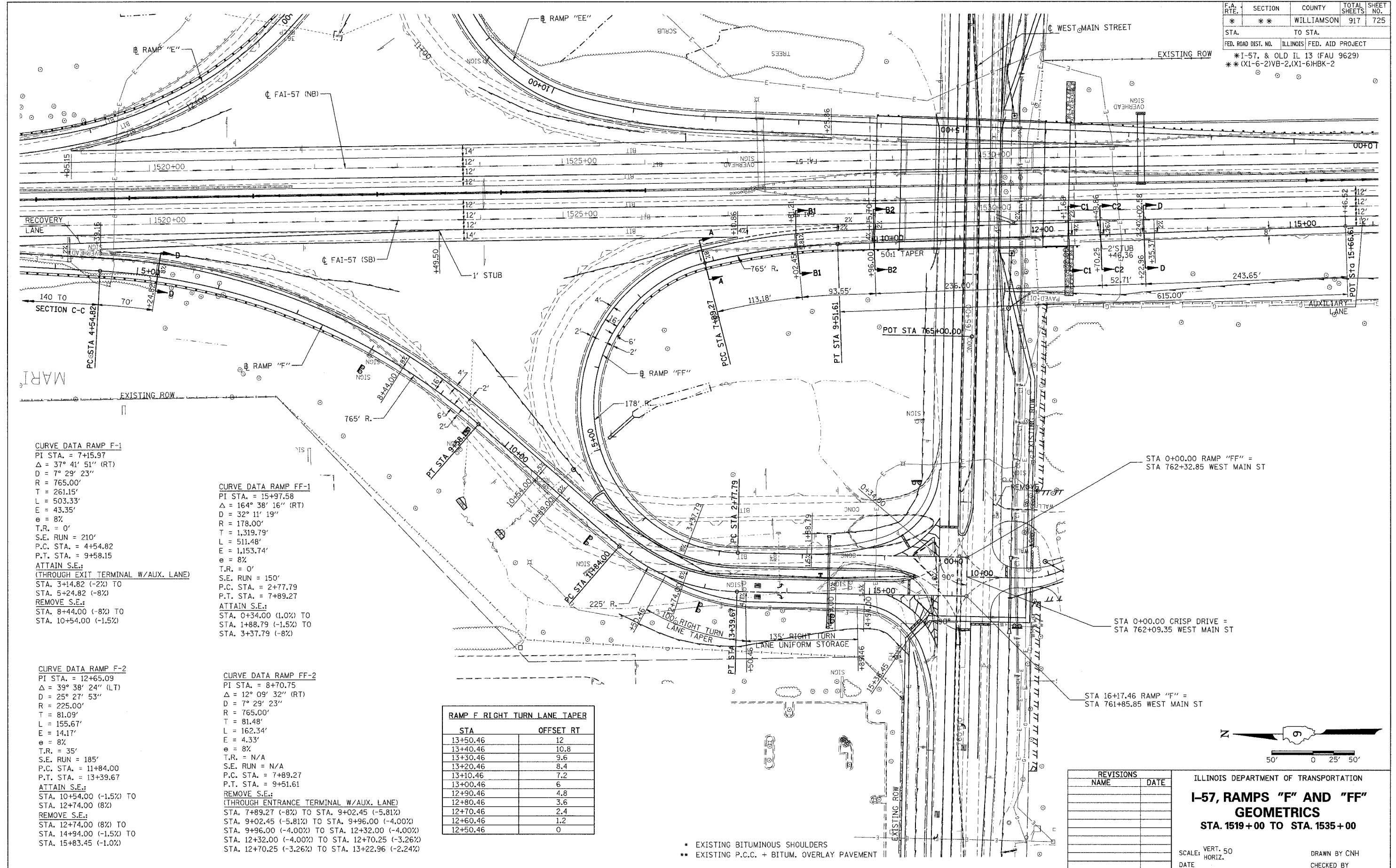

CURVE DATA RAMP F-1
 PI STA. = 7+15.97
 $\Delta = 37^\circ 41' 51''$ (RT)
 $D = 7^\circ 29' 23''$
 $R = 765.00'$
 $T = 261.15'$
 $L = 503.33'$
 $E = 43.35'$
 $e = 8\%$
 $T.R. = 0'$
 $S.E. RUN = 210'$
 $P.C. STA. = 4+54.82$
 $P.T. STA. = 9+58.15$
ATTAIN S.E.:
 (THROUGH EXIT TERMINAL W/AUX. LANE)
 STA. 3+14.82 (-2%) TO
 STA. 5+24.82 (-8%)
REMOVE S.E.:
 STA. 8+44.00 (-8%) TO
 STA. 10+54.00 (-1.5%)

CURVE DATA RAMP FF-1
 PI STA. = 15+97.58
 $\Delta = 164^\circ 38' 16''$ (RT)
 $D = 32^\circ 11' 19''$
 $R = 178.00'$
 $T = 1,319.79'$
 $L = 511.48'$
 $E = 1,153.74'$
 $e = 8\%$
 $T.R. = 0'$
 $S.E. RUN = 150'$
 $P.C. STA. = 2+77.79$
 $P.T. STA. = 7+89.27$
ATTAIN S.E.:
 STA. 0+34.00 (1.0%) TO
 STA. 1+88.79 (-1.5%) TO
 STA. 3+37.79 (-8%)

CURVE DATA RAMP F-2
 PI STA. = 12+65.09
 $\Delta = 39^\circ 38' 24''$ (LT)
 $D = 25^\circ 27' 53''$
 $R = 225.00'$
 $T = 81.09'$
 $L = 155.67'$
 $E = 14.17'$
 $e = 8\%$
 $T.R. = 35'$
 $S.E. RUN = 185'$
 $P.C. STA. = 11+84.00$
 $P.T. STA. = 13+39.67$
ATTAIN S.E.:
 STA. 10+54.00 (-1.5%) TO
 STA. 12+74.00 (8%)
REMOVE S.E.:
 STA. 12+74.00 (8%) TO
 STA. 14+94.00 (-1.5%) TO
 STA. 15+83.45 (-1.0%)

CURVE DATA RAMP FF-2
 PI STA. = 8+70.75
 $\Delta = 12^\circ 09' 32''$ (RT)
 $D = 7^\circ 29' 23''$
 $R = 765.00'$
 $T = 81.48'$
 $L = 162.34'$
 $E = 4.33'$
 $e = 8\%$
 $T.R. = N/A$
 $S.E. RUN = N/A$
 $P.C. STA. = 7+89.27$
 $P.T. STA. = 9+51.61$
REMOVE S.E.:
 (THROUGH ENTRANCE TERMINAL W/AUX. LANE)
 STA. 7+89.27 (-8%) TO STA. 9+02.45 (-5.81%)
 STA. 9+02.45 (-5.81%) TO STA. 9+96.00 (-4.00%)
 STA. 9+96.00 (-4.00%) TO STA. 12+32.00 (-4.00%)
 STA. 12+32.00 (-4.00%) TO STA. 12+70.25 (-3.26%)
 STA. 12+70.25 (-3.26%) TO STA. 13+22.96 (-2.24%)

STA	OFFSET RT
13+50.46	12
13+40.46	10.8
13+30.46	9.6
13+20.46	8.4
13+10.46	7.2
13+00.46	6
12+90.46	4.8
12+80.46	3.6
12+70.46	2.4
12+60.46	1.2
12+50.46	0

REVISIONS	
NAME	DATE

ILLINOIS DEPARTMENT OF TRANSPORTATION
I-57, RAMPS "F" AND "FF"
GEOMETRICS
 STA. 1519+00 TO STA. 1535+00

SCALE: VERT. 50
 DATE: _____
 HORIZ. _____
 DRAWN BY CNH
 CHECKED BY _____

PLT DATE = 12/16/2006
 FILE NAME = c:\p\projects\9828282\1535\1535.dgn
 PLOT SCALE = 50.0000 / 1 IN.
 USER NAME = headen

- * EXISTING BITUMINOUS SHOULDERS
- ** EXISTING P.C.C. + BITUM. OVERLAY PAVEMENT

F.A. RTE.	SECTION	COUNTY	TOTAL SHEETS	SHEET NO.
*	**	WILLIAMSON	917	726
STA. TO STA.				
FED. ROAD DIST. NO. ILLINOIS FED. AID PROJECT				
* I-57, & OLD IL 13 (FAU 9629)				
** (X1-6-2)VB-2, (X1-6)HBK-2				

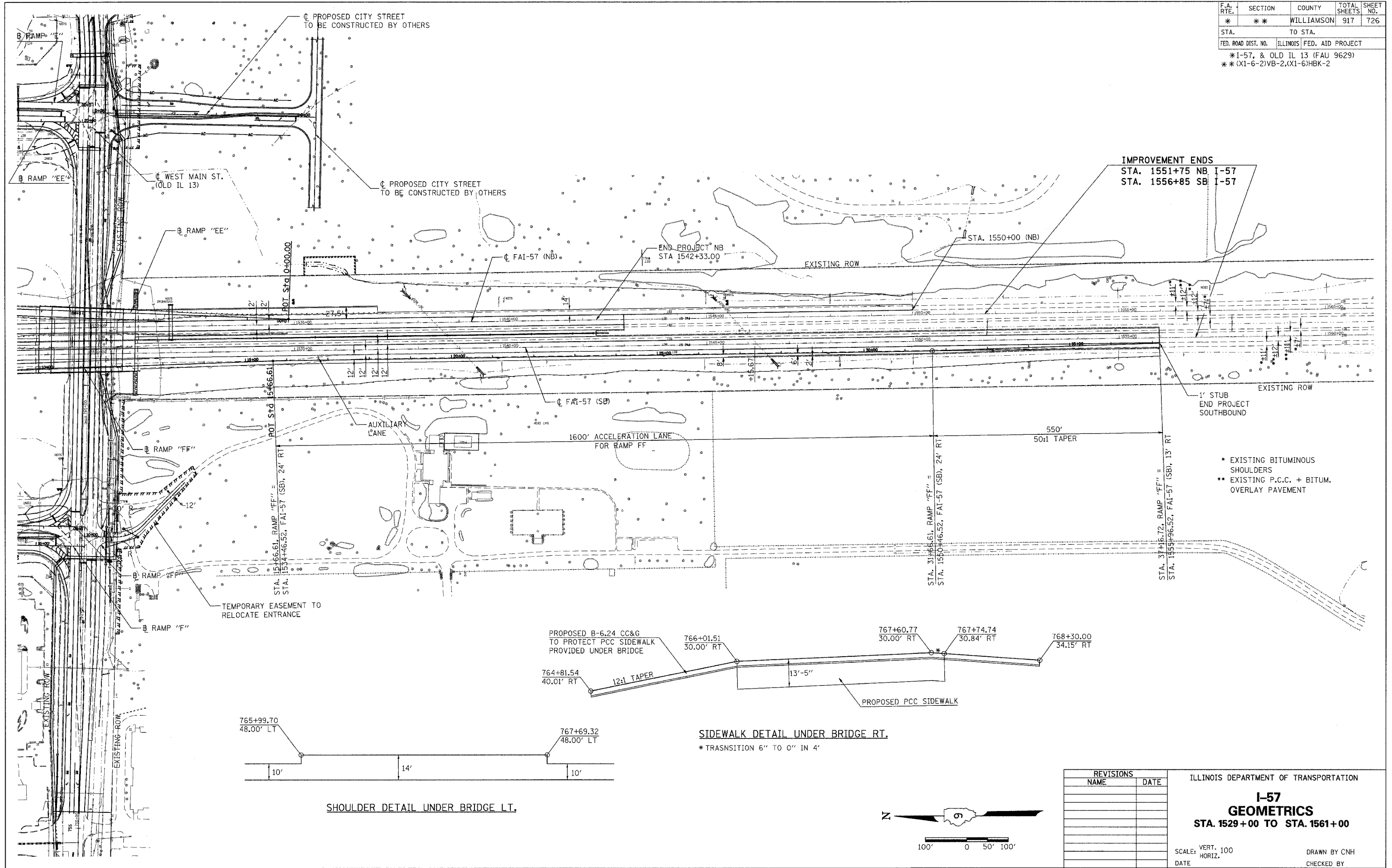

- * EXISTING BITUMINOUS SHOULDERS
- ** EXISTING P.C.C. + BITUM. OVERLAY PAVEMENT

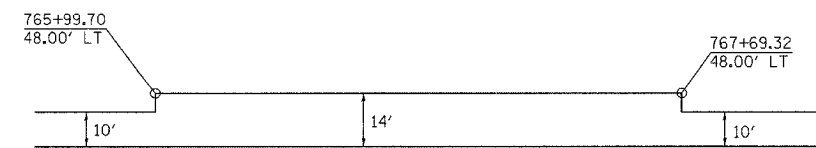
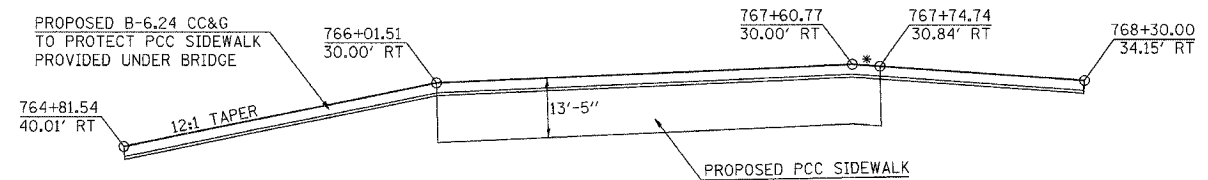

REVISIONS	
NAME	DATE

ILLINOIS DEPARTMENT OF TRANSPORTATION

I-57 GEOMETRICS
 STA. 1529+00 TO STA. 1561+00

SCALE: VERT. 100
 HORIZ. DATE

DRAWN BY CNH
 CHECKED BY

PLOT DATE = 12/16/2006
 FILE NAME = c:\pav\proj\98950\1529+00\1561+00.dgn
 USER NAME = hndeyn

F.A. RTE.	SECTION	COUNTY	TOTAL SHEETS	SHEET NO.
*	**	WILLIAMSON	917	727

STA. TO STA.
 FED. ROAD DIST. NO. ILLINOIS FED. AID PROJECT
 * I-57, & OLD IL 13 (FAU 9629)
 ** (X1-6-2)VB-2, (X1-6)HBK-2

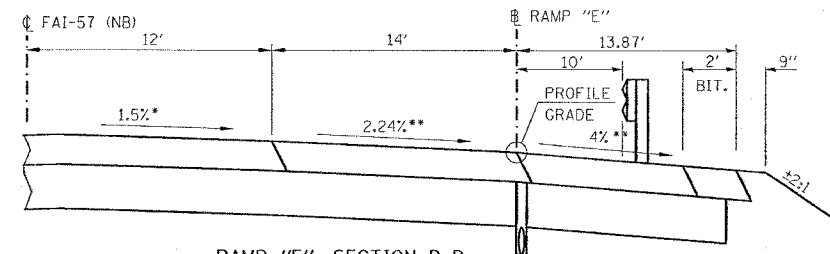

RAMP "E", SECTION D-D
 STA. 19+60.09, RAMP "E"
 (STA. 1512+69.64, FAI-57. SEE DIAGRAM, THIS SHEET)

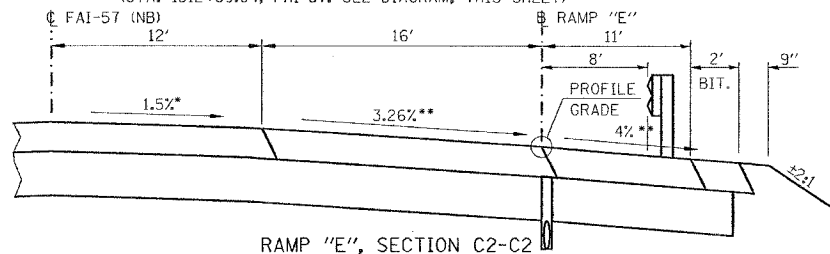

RAMP "E", SECTION C2-C2
 STA. 18+60.09, RAMP "E"
 (STA. 1513+69.66, FAI-57. SEE DIAGRAM, THIS SHEET)

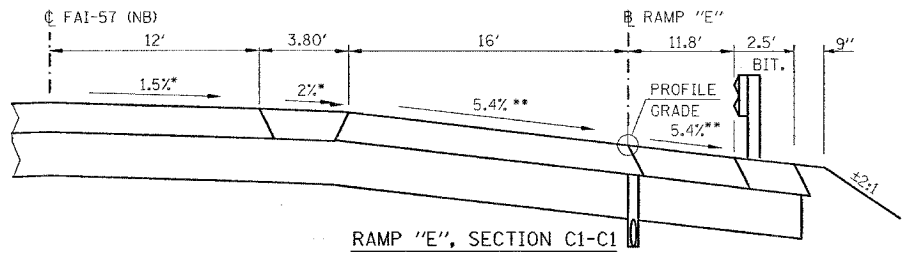

RAMP "E", SECTION C1-C1
 STA. 16+70.00, RAMP "E"
 (STA. 1515+59.71, FAI-57. SEE DIAGRAM, THIS SHEET)

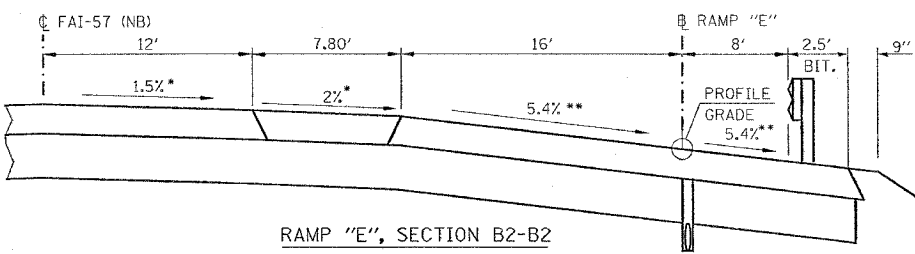

RAMP "E", SECTION B2-B2
 STA. 14+70.00, RAMP "E"
 (STA. 1517+59.67, FAI-57. SEE DIAGRAM, THIS SHEET)

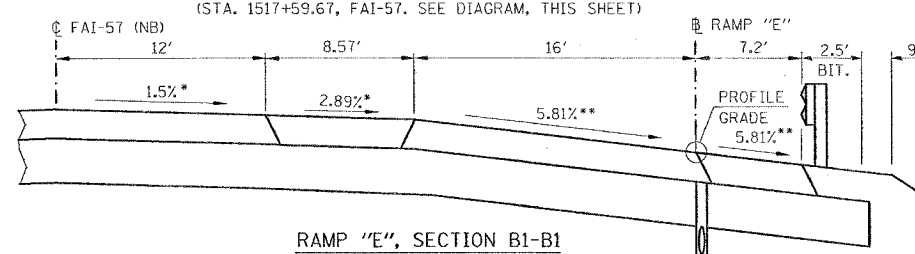

RAMP "E", SECTION B1-B1
 STA. 14+34.99, RAMP "E"
 (STA. 1517+94.89, FAI-57. SEE DIAGRAM, THIS SHEET)

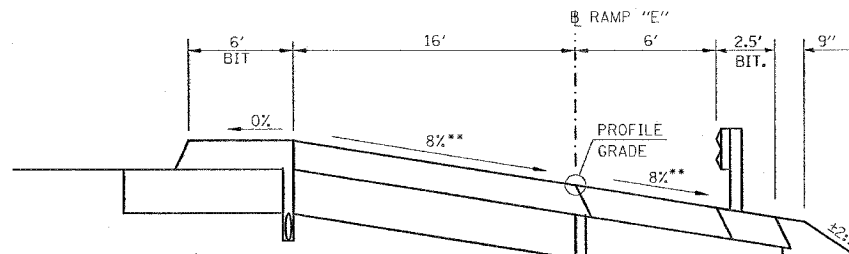

RAMP "E", SECTION A-A
 STA. 13+04.99, RAMP "E"
 (SEE DIAGRAM THIS SHEET)

- * SLOPES SHOWN ⊥ TO MAINLINE
- ** SLOPES SHOWN ⊥ TO RAMP

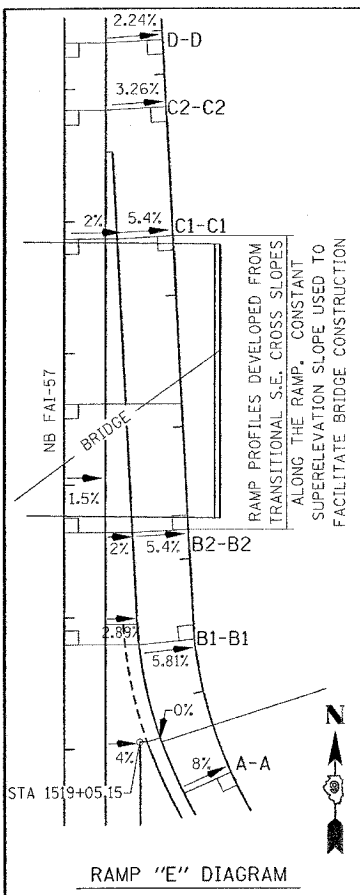

RAMP "E" DIAGRAM

RAMP "EE", SECTION D-D
 STA. 8+70.09, RAMP "EE"
 (SEE DIAGRAM, THIS SHEET)

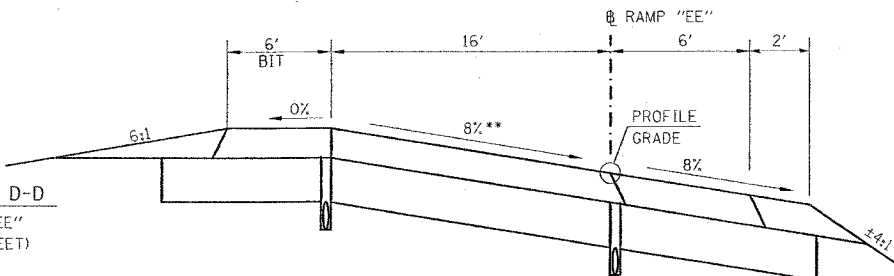

RAMP "EE", SECTION C-C
 STA. 6+60.09, RAMP "EE"
 (STA. 1528+25.86, FAI-57. SEE DIAGRAM, THIS SHEET)

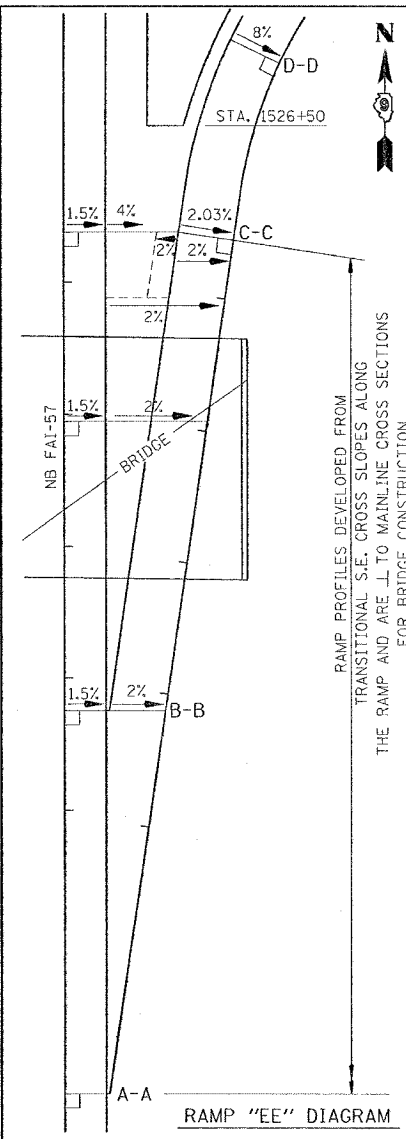
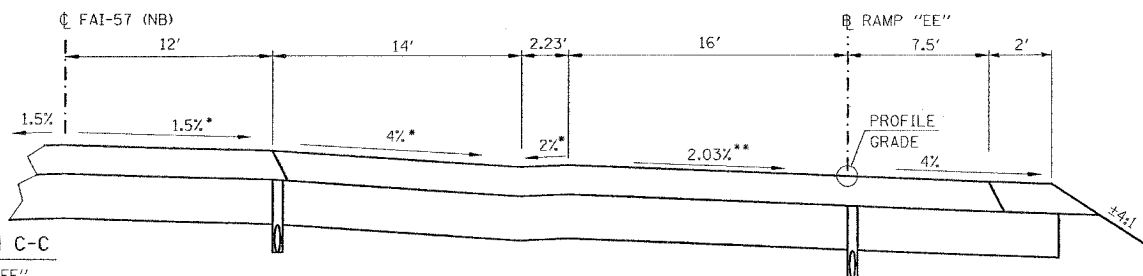

RAMP "EE" DIAGRAM

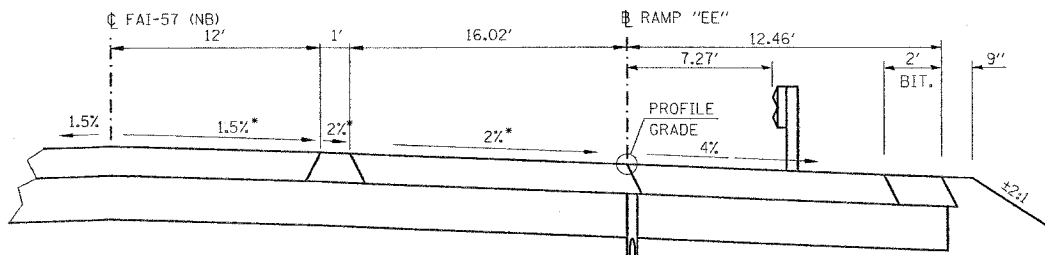

RAMP "EE", SECTION B-B
 STA. 3+00.43, RAMP "EE"
 (STA. 1531+85.86, FAI-57. SEE DIAGRAM, THIS SHEET)

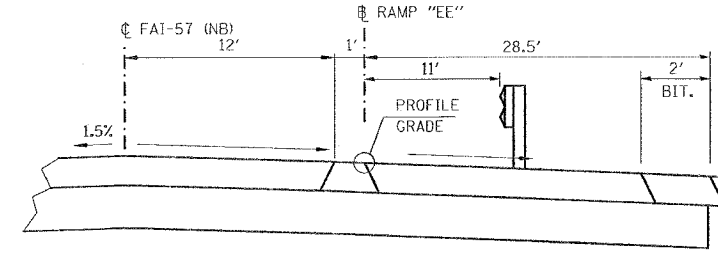

RAMP "EE", SECTION A-A
 STA. 0+00.0, RAMP "EE"
 (STA. 1534+85.86, FAI-57)

- * SLOPES SHOWN ⊥ TO MAINLINE
- ** SLOPES SHOWN ⊥ TO RAMP

REVISIONS	
NAME	DATE

ILLINOIS DEPARTMENT OF TRANSPORTATION

GEOMETRICS

SCALE: VERT. NONE
 HORIZ. DATE

DRAWN BY CNH
 CHECKED BY

F.A. RTE.	SECTION	COUNTY	TOTAL SHEETS	SHEET NO.
*	**	WILLIAMSON	917	728
STA.		TO STA.		
FED. ROAD DIST. NO.		ILLINOIS FED. AID PROJECT		
* I-57, & OLD IL 13 (FAU 9629)				
** (X1-6-2)VB-2, (X1-6)HBK-2				

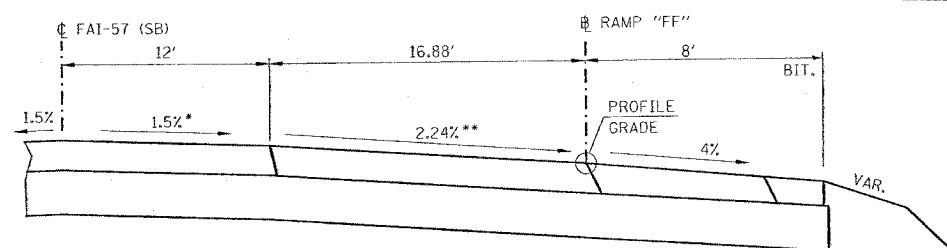

RAMP "FF", SECTION D-D
 STA. 13+22.96, RAMP "FF"
 (STA. 1532+02.58, FAI-57 SEE DIAGRAM, THIS SHEET)

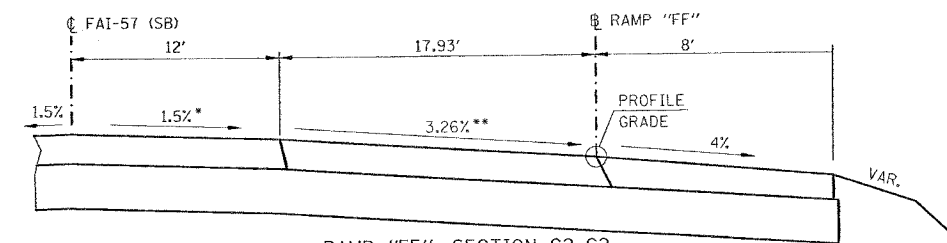

RAMP "FF", SECTION C2-C2
 STA. 12+70.25, RAMP "FF"
 (STA. 1531+49.86, FAI-57 SEE DIAGRAM, THIS SHEET)

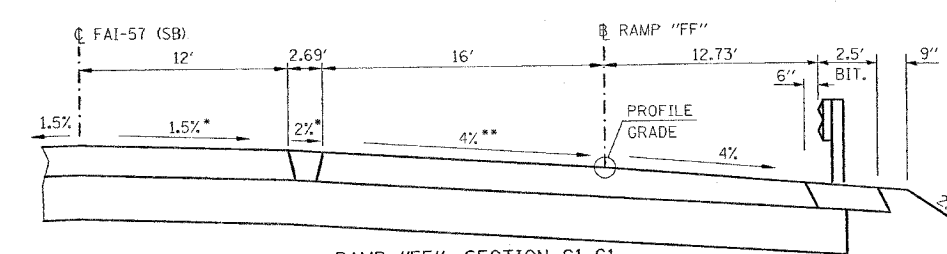

RAMP "FF", SECTION C1-C1
 STA. 12+32.00, RAMP "FF"
 (STA. 1531+11.66, FAI-57 SEE DIAGRAM, THIS SHEET)

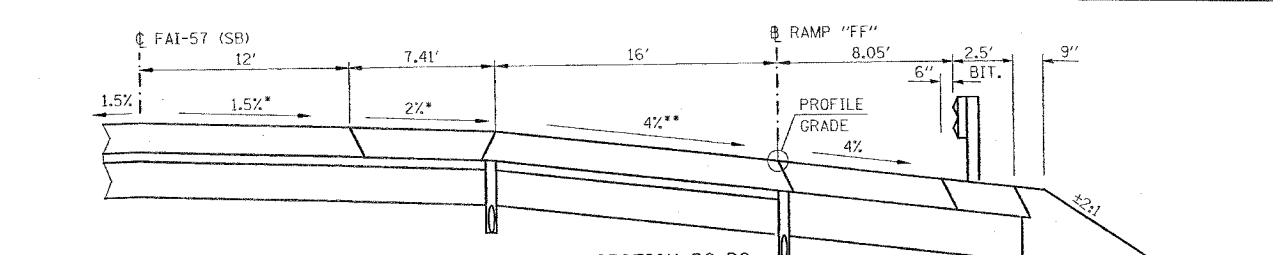

RAMP "FF", SECTION B2-B2
 STA. 9+96.00, RAMP "FF"
 (STA. 1528+75.70, FAI-57. SEE DIAGRAM, THIS SHEET)

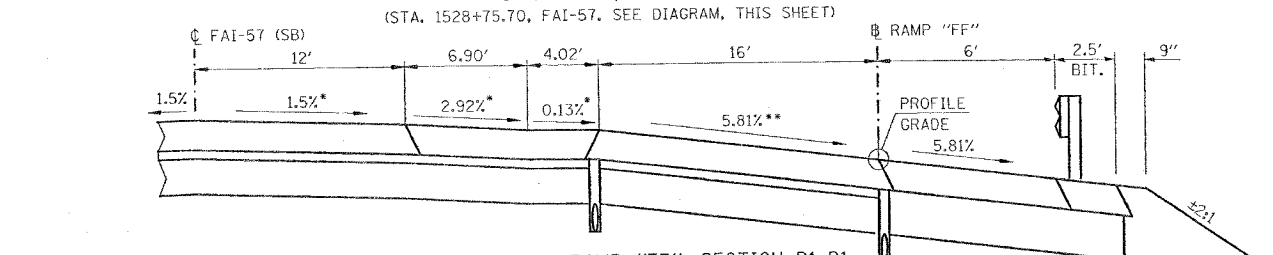

RAMP "FF", SECTION B1-B1
 STA. 9+02.45, RAMP "FF"
 (STA. 1527+81.21, FAI-57. SEE DIAGRAM, THIS SHEET)

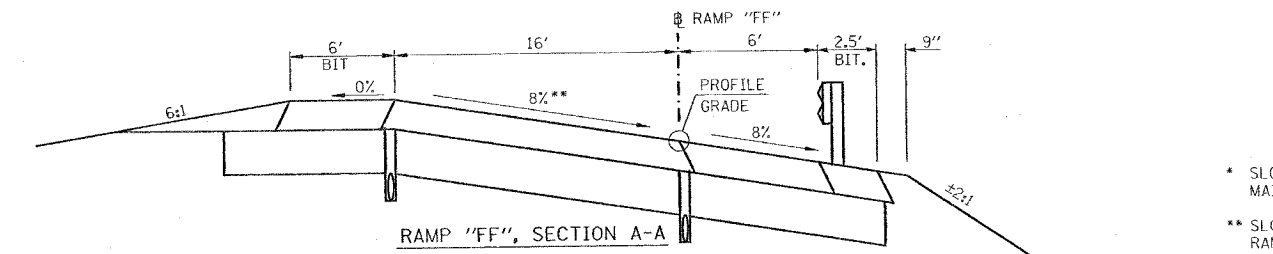

RAMP "FF", SECTION A-A
 STA. 7+89.27, RAMP "FF"

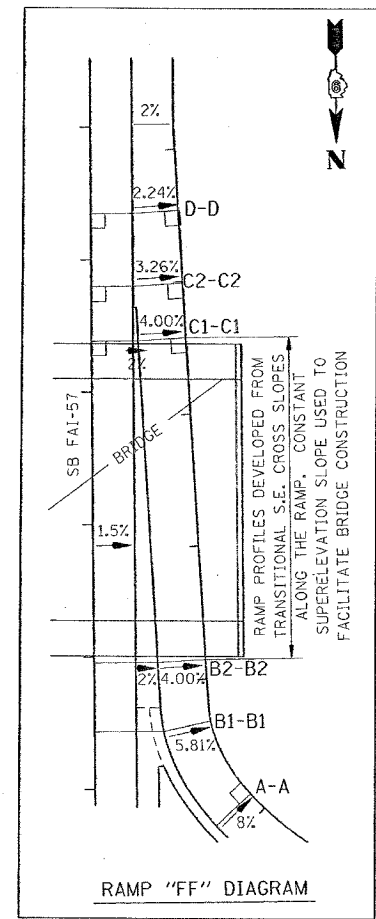

RAMP "FF" DIAGRAM

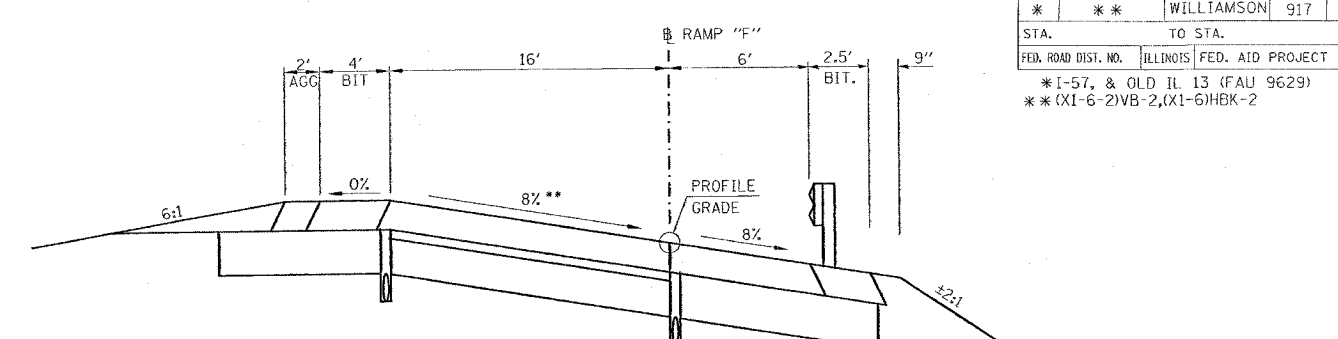

RAMP "F", SECTION D-D
 STA. 5+24.82, RAMP "F"

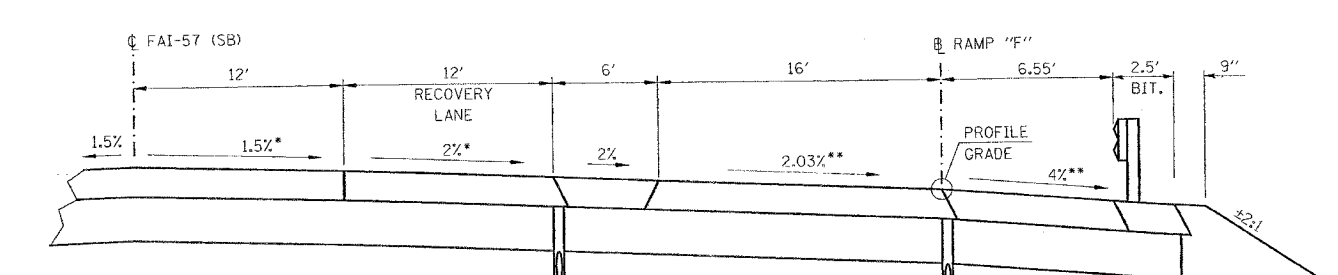

RAMP "F", SECTION C-C (AHEAD)
 STA. 3+14.82, RAMP "F"
 (STA. 1517+99.49, FAI-57. SEE DIAGRAM, THIS SHEET)

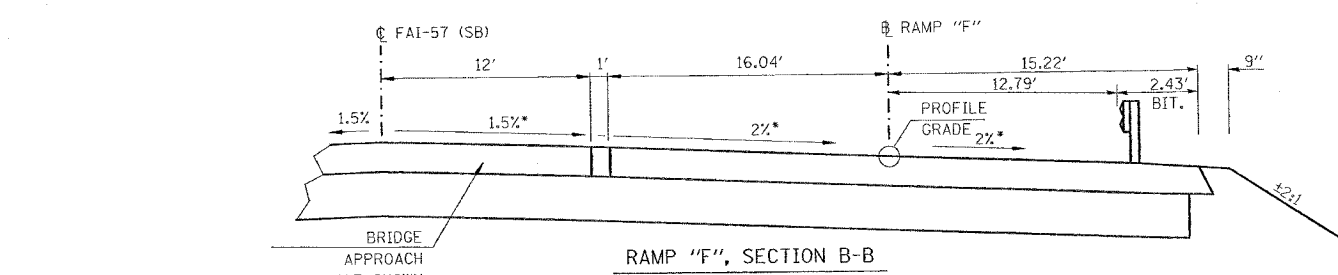

RAMP "F", SECTION B-B
 STA. 0+72.24, RAMP "F"
 (STA. 1515+56.39, FAI-57 SEE DIAGRAM, THIS SHEET)

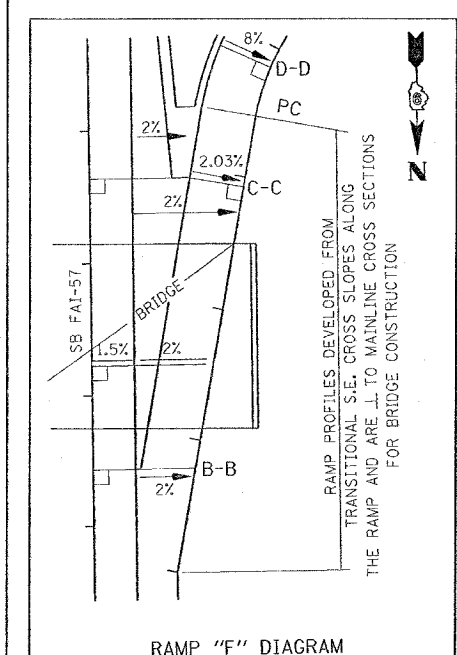

RAMP "F" DIAGRAM

- * SLOPES SHOWN ⊥ TO MAINLINE
- ** SLOPES SHOWN ⊥ TO RAMP

REVISIONS	
NAME	DATE

ILLINOIS DEPARTMENT OF TRANSPORTATION

GEOMETRICS

SCALE: VERT. NONE
 HORIZ. DATE

DRAWN BY CNH
 CHECKED BY

DATE = 10/17/2006
 FILE NAME = c:\p\proj\98950\98950.dgn
 PLOT SCALE = 5/8"=1'-0"
 USER NAME = hndcn

F.A. RTE.	SECTION	COUNTY	TOTAL SHEETS	SHEET NO.
*	**	WILLIAMSON	917	729
STA. TO STA.				
ILLINOIS FED. AID PROJECT				
*I-57, & OLD IL 13 (FAU 9629)				
** (X1-6-2)VB-2, (X1-6)HBK-2				

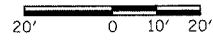
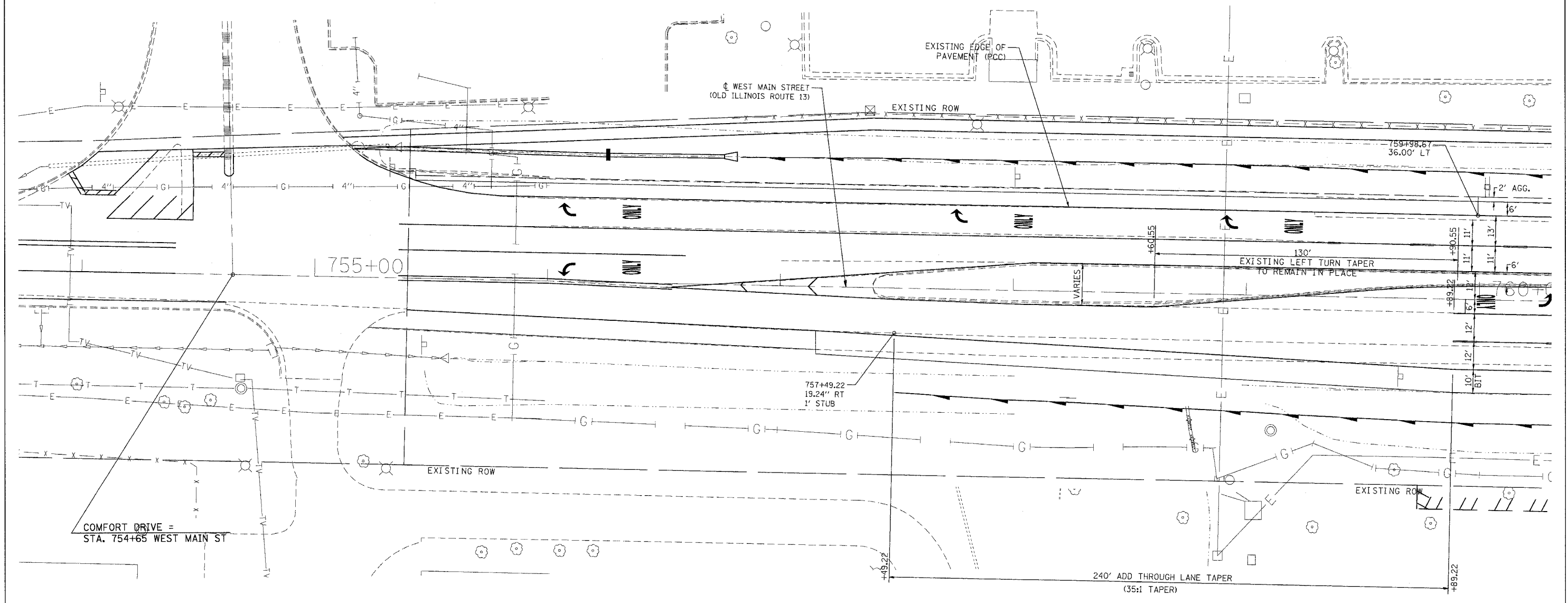

PLOT DATE = 12/6/2006
 FILE NAME = c:\pwork\proj\98950\old\13\geom.dgn
 USER NAME = hanson

REVISIONS	
NAME	DATE

ILLINOIS DEPARTMENT OF TRANSPORTATION

GEOMETRICS
OLD IL 13
STA. 754+00 TO STA. 760+00

SCALE: VERT. 20
 HORIZ. DATE

DRAWN BY CNH
 CHECKED BY

F.A. RTE.	SECTION	COUNTY	TOTAL SHEETS	SHEET NO.
**	**	WILLIAMSON	917	730
STA.	TO STA.			
FED. ROAD DIST. NO. ILLINOIS FED. AID PROJECT				
* I-57, & OLD IL 13 (FAU 9629)				
** (X1-6-2)VB-2,(X1-6)HBK-2				

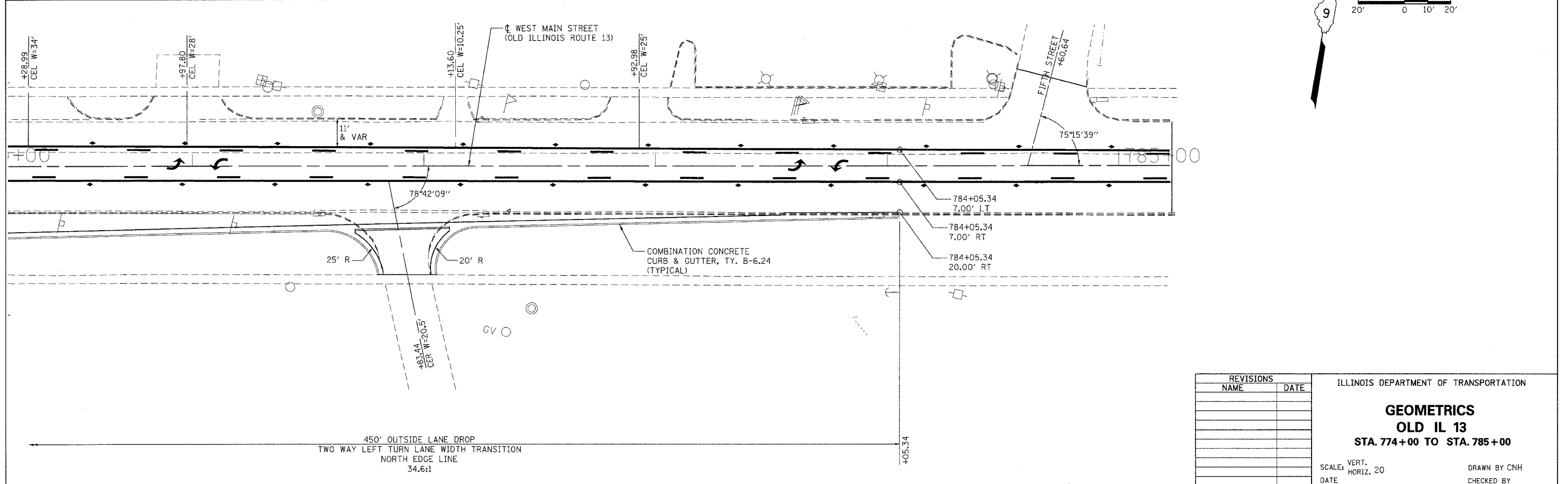
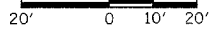
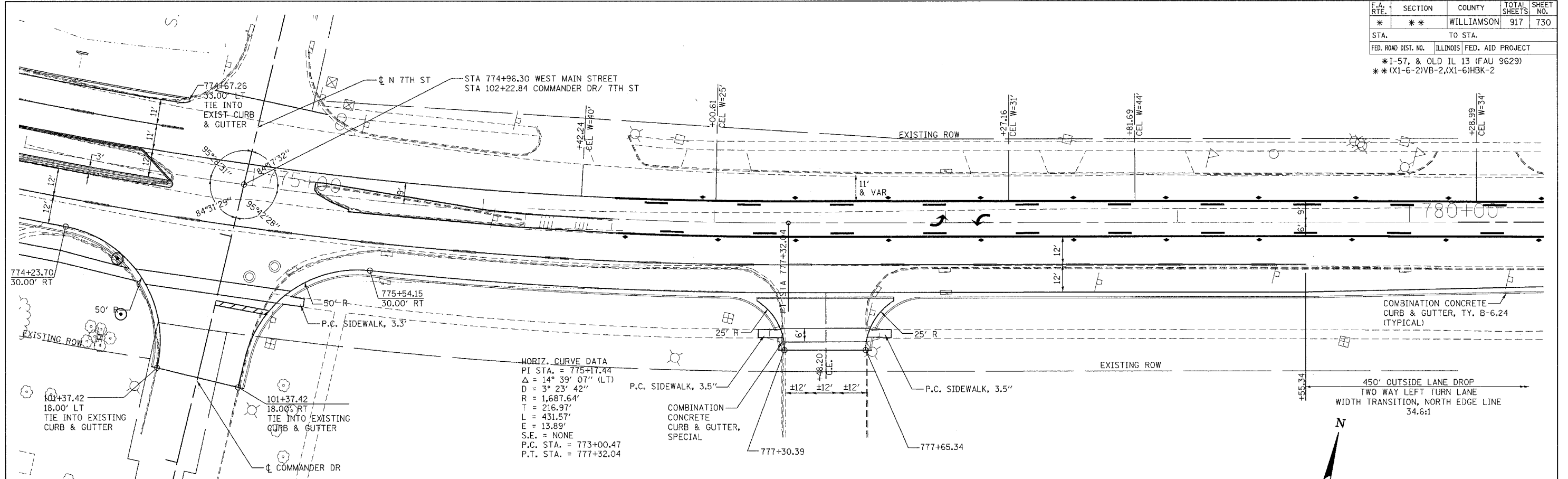

PLOT DATE = 12/6/2006
 FILE NAME = c:\npr\p01\p01\0313\0113\0113\p01.dgn
 PLOT SCALE = 20.00000 / 1 IN.
 USER NAME = hudson

REVISIONS	
NAME	DATE

ILLINOIS DEPARTMENT OF TRANSPORTATION

GEOMETRICS
OLD IL 13
STA. 774+00 TO STA. 785+00

SCALE: VERT. 20'
 DATE: _____

DRAWN BY CNH
 CHECKED BY _____

F.A. RTE.	SECTION	COUNTY	TOTAL SHEETS	SHEET NO.
*	**	WILLIAMSON	917	731

STA. TO STA.
ILLINOIS FED. AID PROJECT

* I-57, & OLD IL 13 (FAU 9629)
** (X1-6-2)VB-2, (X1-6)HBK-2

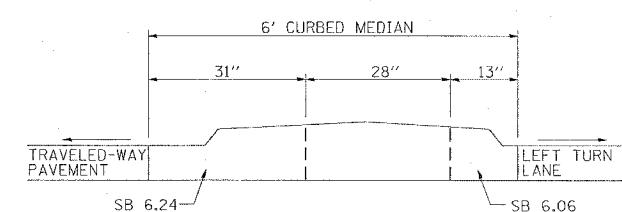
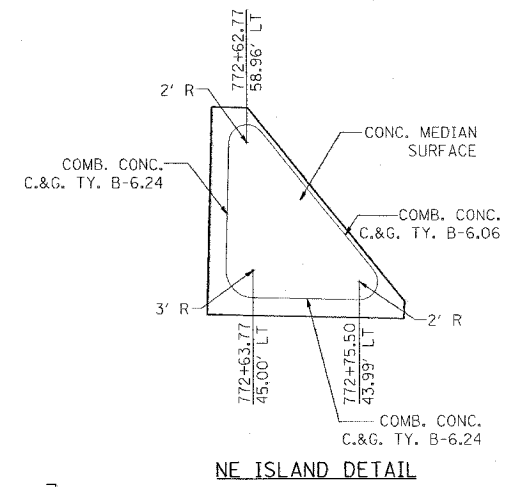
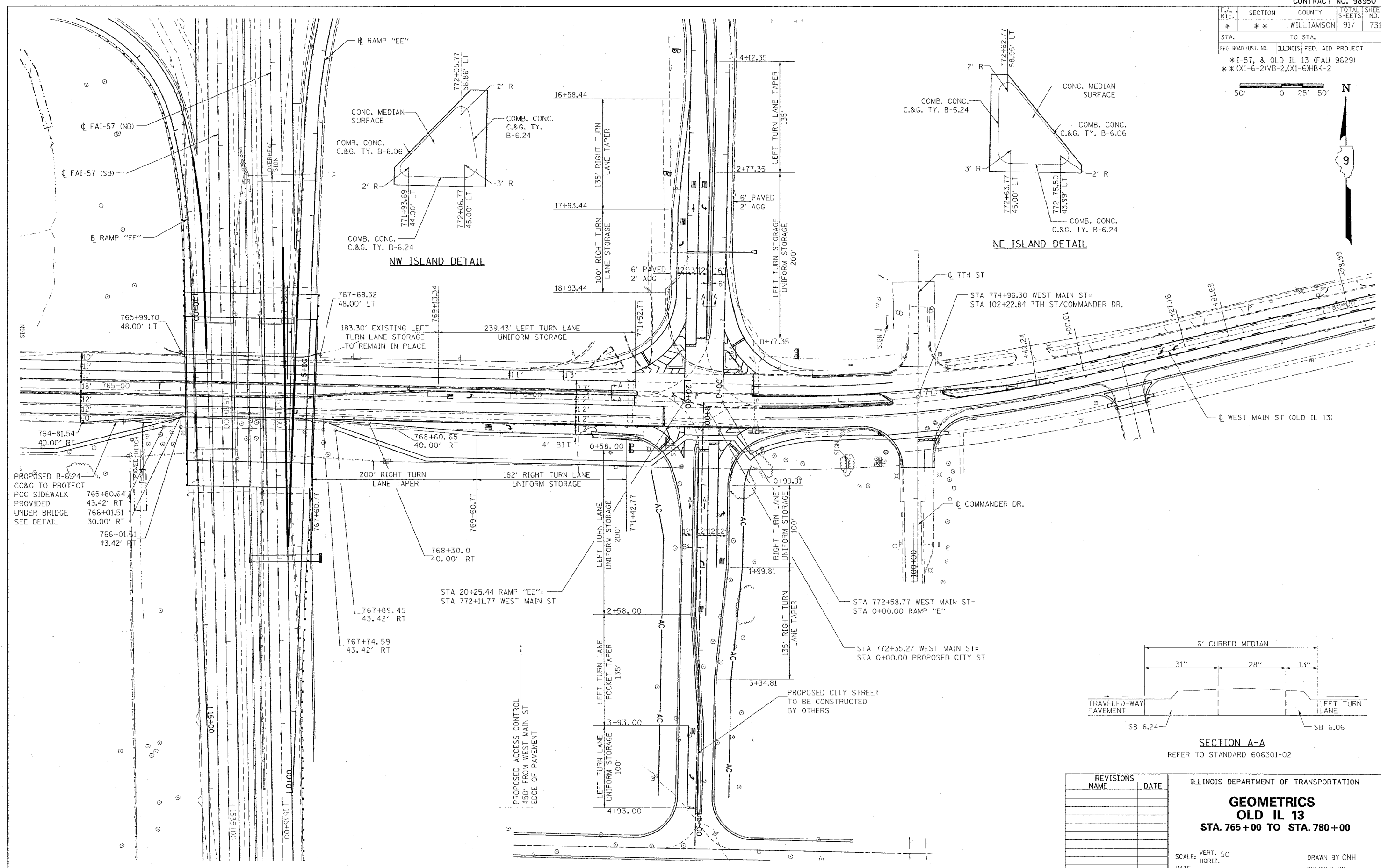
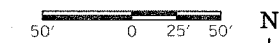

SECTION A-A
REFER TO STANDARD 606301-02

REVISIONS	
NAME	DATE

ILLINOIS DEPARTMENT OF TRANSPORTATION
GEOMETRICS
OLD IL 13
STA. 765+00 TO STA. 780+00
SCALE: VERT. 50
DATE: _____
DRAWN BY CNH
CHECKED BY _____

PLOT DATE = 11/21/2006
FILE NAME = c:\projects\982802\old13\old13.dgn
PLOT SCALE = 50.0000
USER NAME = henden

F.A. RTE.	SECTION	COUNTY	TOTAL SHEETS	SHEET NO.
*	**	WILLIAMSON	917	732

STA. TO STA.

FED. ROAD DIST. NO. ILLINOIS FED. AID PROJECT
 *I-57, & OLD IL 13 (FAU 9629)
 ** (X1-6-2)VB-2, (X1-6)HKB-2

STATIONING ALONG WEST MAIN ST (IL 13)	OFFSET TO E.P. FEET	EDGE OF PAV'T. ELEV. FEET	STATIONING ALONG RAMP "EE"	OFFSET TO E.P. FEET	DISTANCE ALONG RADIUS FEET
LT. 770+62.97	36.00	450.70			10
LT. 770+72.97	36.23	450.62			10
LT. 770+82.94	36.91	450.53			10
LT. 770+92.88	38.04	450.42			10
LT. 771+02.75	39.63	450.32			10
LT. 771+12.54	41.66	450.23			10
LT. 771+22.23	44.13	450.12			10
LT. 771+31.80	47.04	450.01			10
LT. 771+41.22	50.39	449.89			10
LT. 771+50.45	54.22	449.76	RT. 19+71.22	61.31	10
		449.61	RT. 19+66.44	52.53	10
		449.45	RT. 19+60.67	44.37	10
		449.28	RT. 19+53.99	36.93	10
		449.10	RT. 19+46.50	30.32	10
		448.93	RT. 19+38.29	24.62	10
		448.85	RT. 19+29.47	19.91	10
		448.86	RT. 19+20.17	16.26	10
		448.93	RT. 19+10.51	13.71	10
		449.00	RT. 19+00.61	12.30	10
					7.18

STATIONING ALONG WEST MAIN ST (IL 13)	OFFSET TO E.P. FEET	EDGE OF PAV'T. ELEV. FEET	STATIONING ALONG RAMP "E"	OFFSET TO E.P. FEET	DISTANCE ALONG RADIUS FEET
LT. 773+68.98	33.00	449.06			10
LT. 773+58.79	33.50	449.09			10
LT. 773+48.70	34.98	449.09			10
LT. 773+38.80	37.43	449.07			10
LT. 773+29.18	40.84	449.02			10
LT. 773+19.93	45.16	448.96			10
LT. 773+11.15	50.36	448.88			10
LT. 773+02.92	56.39	448.78			10
LT. 772+95.51	63.20	448.68	RT. 0+70.74	30.19	10
LT. 772+88.95	70.74	448.63	RT. 0+78.92	24.45	10
		448.71	RT. 0+87.66	19.60	10
		448.79	RT. 0+96.87	15.70	10
		448.88	RT. 1+06.38	12.63	10
		448.99	RT. 1+16.01	9.92	10
		449.12	RT. 1+25.72	7.53	10
		449.25	RT. 1+35.50	5.47	10
		449.38	RT. 1+45.35	3.73	10
		449.49	RT. 1+55.25	2.33	10
		449.62	RT. 1+65.19	1.25	10
		449.72	RT. 1+75.16	0.50	10
		449.82	RT. 1+85.15	0.09	10
					7.38

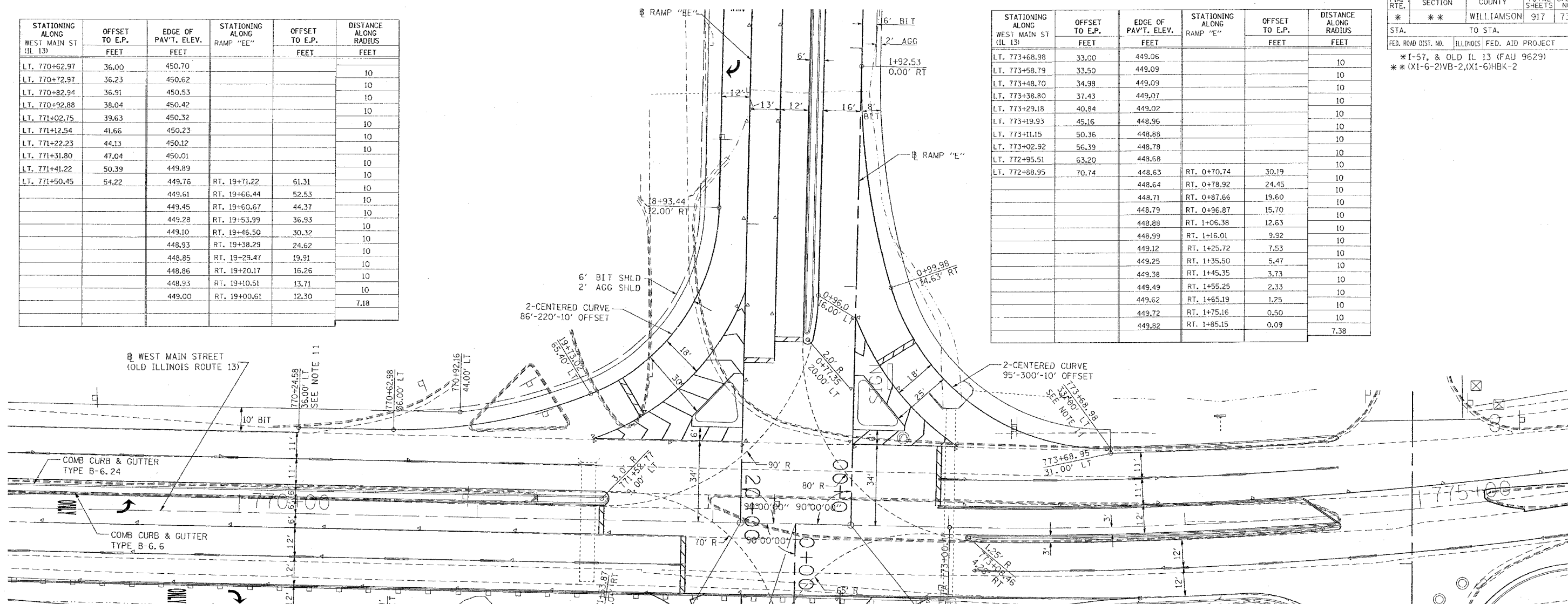

STATIONING ALONG WEST MAIN ST OLD IL 13	OFFSET TO E.P. FEET	EDGE OF PAV'T. ELEV. FEET	STATIONING ALONG NEW CITY STREET	OFFSET TO E.P. FEET	DISTANCE ALONG RADIUS FEET
RT. 771+42.77	42.00	449.77			10
RT. 771+52.72	42.83	449.68			10
RT. 771+62.40	45.30	449.56			10
RT. 771+71.53	49.34	449.42			10
RT. 771+79.87	54.85	449.26	RT. 0+49.34	63.73	10
RT. 771+87.18	61.66	449.09	RT. 0+61.65	48.09	10
RT. 771+93.25	69.58	448.90	RT. 0+59.58	42.01	10
RT. 771+97.93	78.41	448.78	RT. 0+78.41	37.33	10
RT. 772+01.25	87.83	448.71	RT. 0+87.83	34.01	10
RT. 772+04.06	97.43	448.68	RT. 0+97.43	31.20	10
RT. 772+06.48	107.13	448.69	RT. 1+07.13	28.78	10
		448.74	RT. 1+16.92	26.75	10
		448.83	RT. 1+26.79	25.11	10
		448.94	RT. 1+36.71	23.87	10
		449.06	RT. 1+46.67	23.02	10
		449.20	RT. 1+56.66	22.58	10
					6.17

STATIONING ALONG WEST MAIN ST OLD IL 13	OFFSET TO E.P. FEET	EDGE OF PAV'T. ELEV. FEET	STATIONING ALONG NEW CITY STREET	OFFSET TO E.P. FEET	DISTANCE ALONG RADIUS FEET
RT. 773+80.03	30.00	448.75			10
RT. 773+70.21	30.23	448.78			10
RT. 773+60.42	30.92	448.80			10
RT. 773+50.66	32.06	448.81			10
RT. 773+40.98	33.65	448.82			10
RT. 773+31.39	35.70	448.82			10
RT. 773+21.91	38.19	448.81			10
RT. 773+12.57	41.12	448.79			10
RT. 773+03.40	44.51	448.76			10
RT. 772+94.63	49.14	448.71	LT. 0+49.14	59.36	10
RT. 772+86.67	55.18	448.62	LT. 0+55.18	51.40	10
RT. 772+79.82	62.44	448.51	LT. 0+62.45	44.55	10
RT. 772+74.27	70.75	448.40	LT. 0+70.75	39.00	10
RT. 772+70.18	79.86	448.33	LT. 0+79.86	34.91	10
		448.29	LT. 0+89.53	32.99	10
		448.29	LT. 0+99.48	31.50	10
					0.33

REVISIONS	
NAME	DATE

ILLINOIS DEPARTMENT OF TRANSPORTATION
GEOMETRICS
OLD IL 13
RAMPS "E" AND "EE"
STA. 770+00 TO STA. 775+00
 SCALE: VERT. 20
 DATE: _____ DRAWN BY CNH
 CHECKED BY _____

PLOT DATE = 10/17/2006
 FILE NAME = 98950202\oldil13\geom\geom.dgn
 PLOT SCALE = 20/1000
 USER NAME = headon

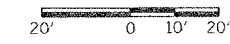

F.A. RTE.	SECTION	COUNTY	TOTAL SHEETS	SHEET NO.
*	**	WILLIAMSON	917	733

STA. TO STA.
 FED. ROAD DIST. NO. ILLINOIS FED. AID PROJECT
 * I-57, & OLD IL 13 (FAU 9629)
 ** (X1-6-2)VB-2, (X1-6)HBK-2

STATIONING ALONG WEST MAIN ST (IL 13)	OFFSET TO E.P. FEET	EDGE OF PAV'T. ELEV. FEET	STATIONING ALONG RAMP "F" FEET	OFFSET TO E.P. FEET	DISTANCE ALONG RADIUS FEET
LT. 760+37.06	36.00	447.42			10
LT. 760+47.06	36.23	447.52			10
LT. 760+57.03	36.91	447.62			10
LT. 760+66.97	38.04	447.71			10
LT. 760+76.84	39.63	447.78			10
LT. 760+86.63	41.66	447.85			10
LT. 760+96.32	44.13	447.91			10
LT. 761+05.88	47.04	447.96			10
LT. 761+15.31	50.39	448.00			10
		448.04	RT. 15+67.07	70.55	10
		448.04	RT. 15+63.24	61.31	10
		448.04	RT. 15+58.46	52.54	10
		448.09	RT. 15+52.69	44.37	10
		448.19	RT. 15+46.01	36.94	10
		448.32	RT. 15+38.52	30.32	10
		448.47	RT. 15+30.31	24.62	10
		448.63	RT. 15+21.49	19.91	10
		448.80	RT. 15+12.19	16.26	10
		448.99	RT. 15+02.53	13.71	10
		449.18	RT. 14+92.63	12.30	10
					7.18

STATIONING ALONG WEST MAIN ST (IL 13)	OFFSET TO E.P. FEET	EDGE OF PAV'T. ELEV. FEET	STATIONING ALONG RAMP "FF" FEET	OFFSET TO E.P. FEET	DISTANCE ALONG RADIUS FEET
LT. 763+37.85	36.00	450.49			10
LT. 763+27.87	36.53	450.39			10
LT. 763+18.00	38.10	450.28			10
LT. 763+08.35	40.70	450.15			10
LT. 762+99.02	44.30	450.00			10
LT. 762+90.13	48.86	449.83			10
LT. 762+81.76	54.33	449.65			10
LT. 762+74.02	60.64	449.46			10
LT. 762+66.98	67.74	449.26			10
LT. 762+60.72	75.54	449.07	RT. 0+75.54	27.87	10
		448.99	RT. 0+83.95	22.47	10
		449.02	RT. 0+92.88	17.98	10
		449.14	RT. 1+02.23	14.46	10
		449.29	RT. 1+11.80	11.55	10
		449.43	RT. 1+21.46	8.96	10
		449.59	RT. 1+31.20	6.70	10
		449.75	RT. 1+41.01	4.76	10
		449.94	RT. 1+50.88	3.15	10
		450.12	RT. 1+60.80	1.87	10
		450.32	RT. 1+70.75	0.92	10
		450.52	RT. 1+80.73	0.30	10
		450.74	RT. 1+90.73	0.02	3.52

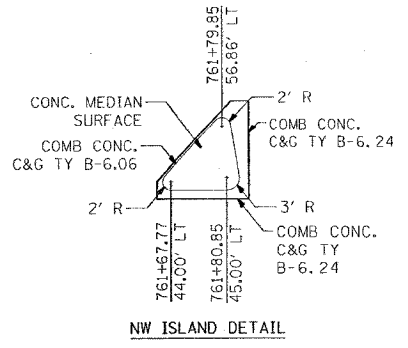
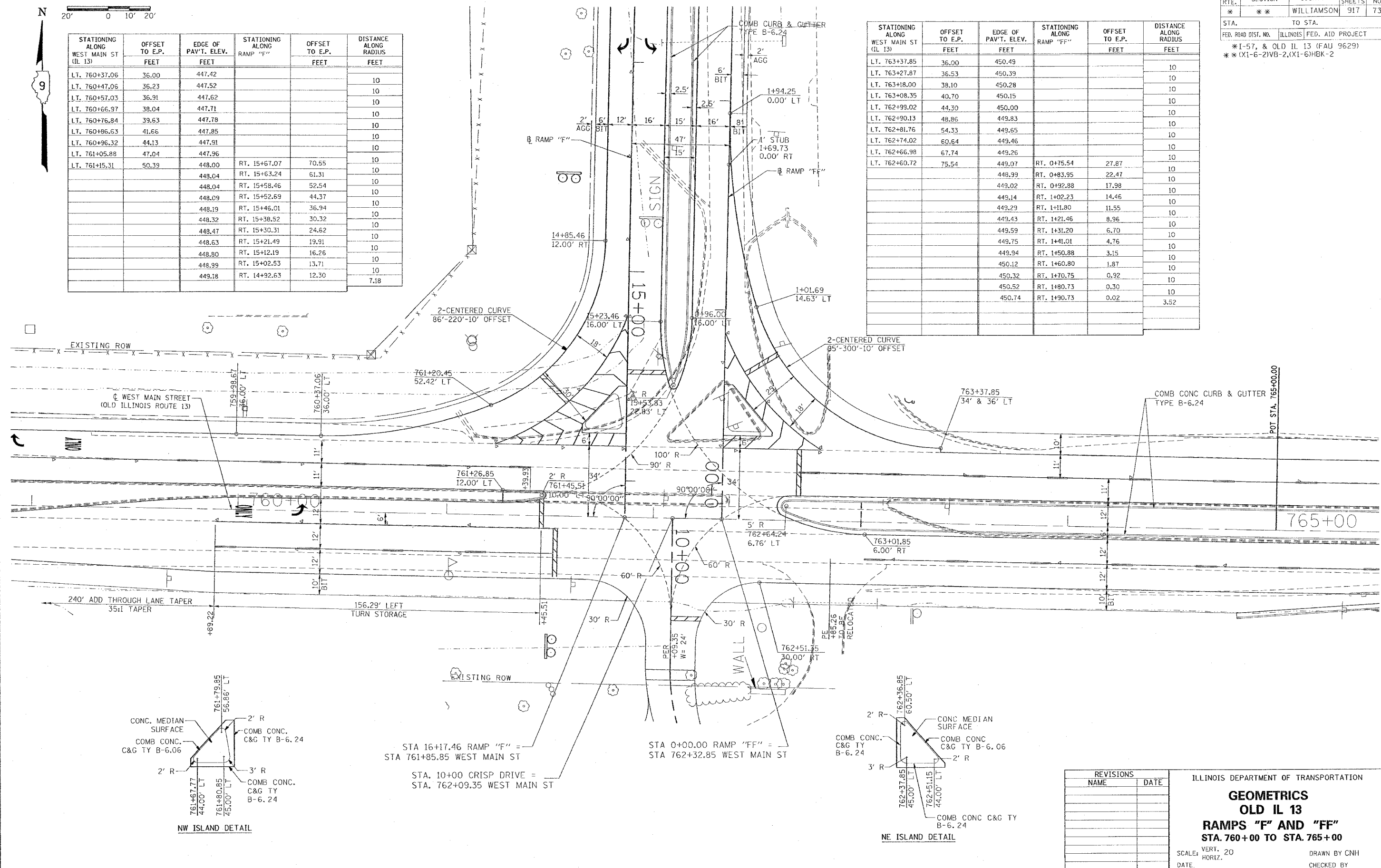

STA 16+17.46 RAMP "F" =
 STA 761+85.85 WEST MAIN ST

STA 10+00 CRISP DRIVE =
 STA. 762+09.35 WEST MAIN ST

STA 0+00.00 RAMP "FF" =
 STA 762+32.85 WEST MAIN ST

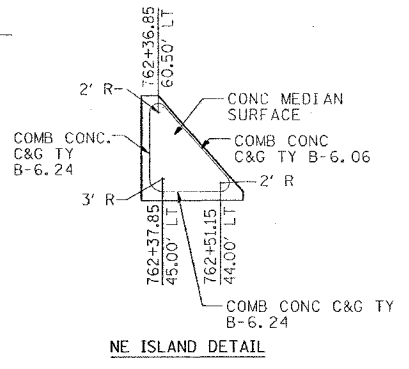

REVISIONS	
NAME	DATE

ILLINOIS DEPARTMENT OF TRANSPORTATION

GEOMETRICS
OLD IL 13
RAMPS "F" AND "FF"
STA. 760+00 TO STA. 765+00

SCALE: VERT. 20
 HORIZ. 1" = 40'

DATE: _____ DRAWN BY CNH
 CHECKED BY _____

PLOT DATE = 10/17/2006
 FILE NAME = c:\projects\982282\old13\old13p6.dgn
 PLOT SCALE = 20.0000
 USER NAME = heden

F.A. RTE.	SECTION	COUNTY	TOTAL SHEETS	SHEET NO.
*	**	WILLIAMSON	917	734
STA.		TO STA.		
FED. ROAD DIST. NO.		ILLINOIS FED. AID PROJECT		
* I-57, & OLD IL 13 (FAU 9629)				
** (X1-6-2)VB-2,(X1-6)HBK-2				

EXIST. CURVE NBL102
 PI STA. = 1496+40.64
 $\Delta = 18^\circ 56' 34''$ (LT)
 $D = 0^\circ 40' 00''$
 $R = 8,594.33'$
 $T = 1,433.79'$
 $L = 2,841.41'$
 $E = 118.78'$
 $e =$
 P.C. STA. = 1482+06.85
 P.T. STA. = 1510+48.26

IMPROVEMENT BEGINS
 STA. 1500+00 SB I-57

EXIST. CURVE SBL102
 PI STA. = 1495+35.88
 $\Delta = 18^\circ 56' 34''$ (LT)
 $D = 0^\circ 40' 00''$
 $R = 8,594.33'$
 $T = 1,433.79'$
 $L = 2,841.41'$
 $E = 118.78'$
 $e =$
 P.C. STA. = 1481+02.09
 P.T. STA. = 1509+43.50

PROJECT BEGINS
 STA. 1506+90 NB I-57

THERMOPLASTIC PAVEMENT MARKING - LINE 4"
 (SOLID YELLOW)

THERMOPLASTIC PAVEMENT MARKING - LINE 12"
 (SOLID WHITE) (TYP.)

PREFORMED PLASTIC PAVEMENT
 MARKING TYPE 3 - LINE 4"
 (WHITE SKIP DASH)

THERMOPLASTIC PAVEMENT MARKING - LINE 4"
 (SOLID WHITE)

THERMOPLASTIC PAVEMENT MARKING - LINE 4"
 (SOLID YELLOW)

I-57 NB

I-57 SB

THERMOPLASTIC PAVEMENT MARKING - LINE 4"
 (SOLID WHITE)

THERMOPLASTIC PAVEMENT MARKING - LINE 8"
 (SOLID WHITE)

EXISTING RAMP "C"

THERMOPLASTIC PAVEMENT MARKING - LINE 4"
 (SOLID WHITE)

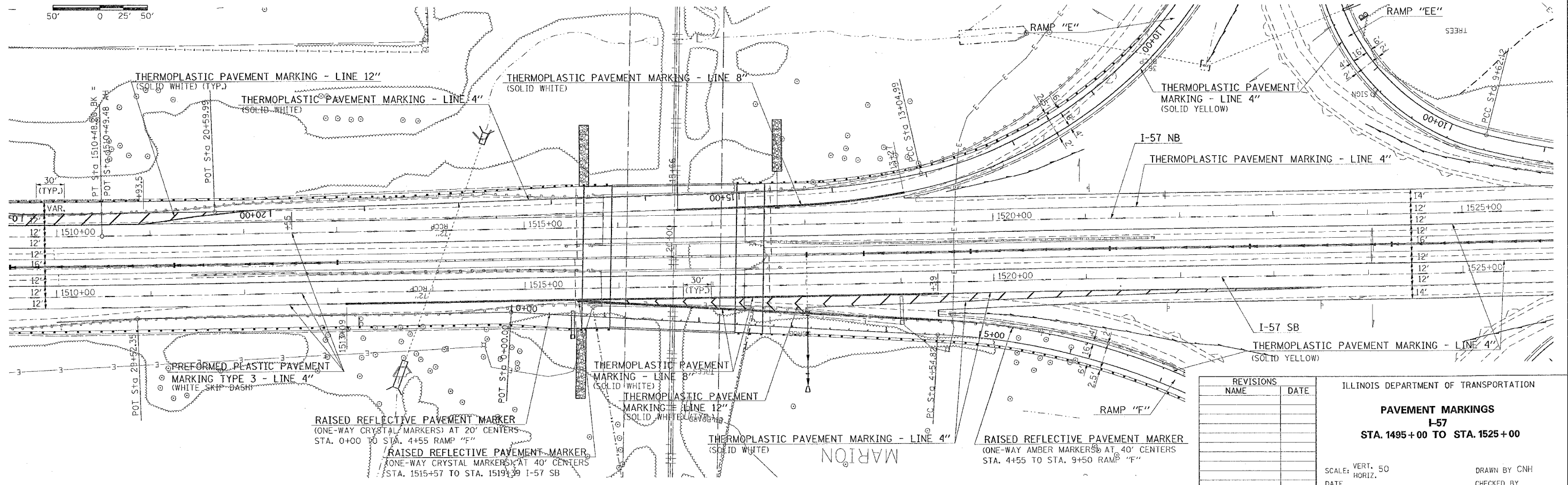

REVISIONS	
NAME	DATE

ILLINOIS DEPARTMENT OF TRANSPORTATION

PAVEMENT MARKINGS

I-57

STA. 1495+00 TO STA. 1525+00

SCALE: VERT. 50
 HORIZ. 1" = 40'

DATE _____ DRAWN BY CNH
 CHECKED BY _____

PLOT DATE = 10/24/2006
 PLOT SCALE = 1/4" = 100'
 USER NAME = hnsden

F.A. RTE.	SECTION	COUNTY	TOTAL SHEETS	SHEET NO.
*	*	WILLIAMSON	917	735
STA.		TO STA.		
FED. ROAD DIST. NO.		ILLINOIS FED. AID PROJECT		

* I-57, & OLD IL 13 (FAU 9629)
 ** (X13-6-2)VB-2,(X1-6)HBK-2

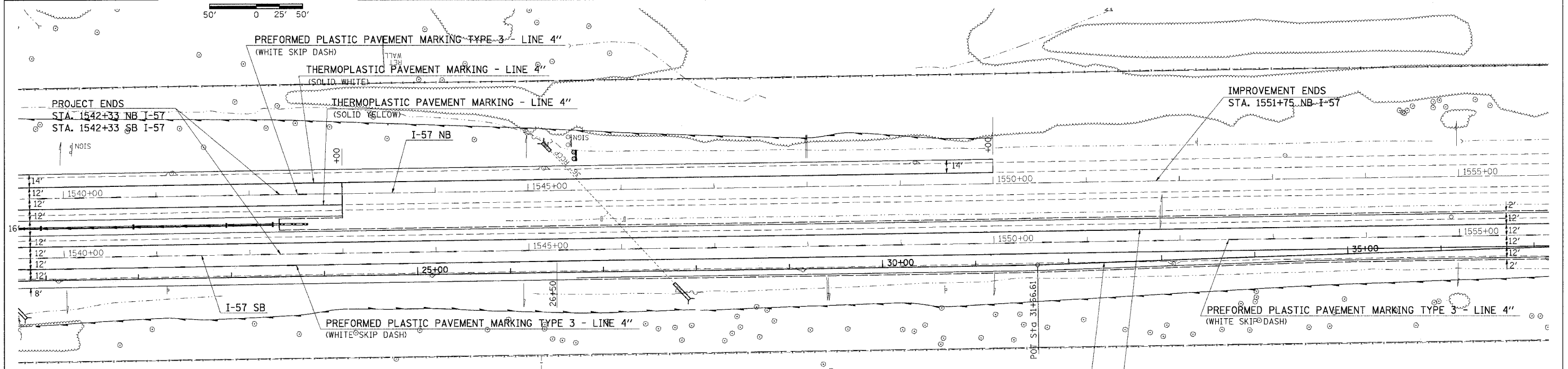
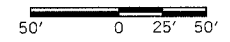
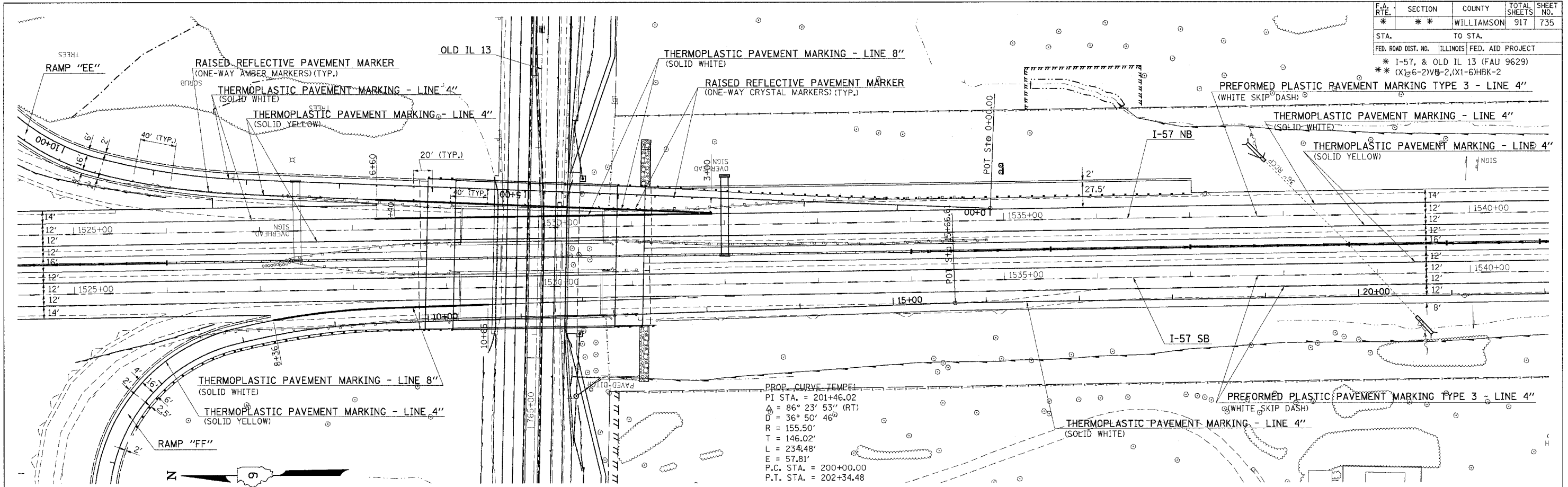

REVISIONS	
NAME	DATE

ILLINOIS DEPARTMENT OF TRANSPORTATION
PAVEMENT MARKINGS
I-57
STA. 1525+00 TO STA. 1555+00

SCALE: VERT. 50
 DATE
 DRAWN BY CNH
 CHECKED BY

PLOT DATE = 12/7/2006
 FILE NAME = c:\p\projects\98950\13\1313\1313.dwg
 PLOT SCALE = 1/4" = 100'
 USER NAME = hceden

CONTRACT NO. 98950

F.A. RTE.	SECTION	COUNTY	TOTAL SHEETS	SHEET NO.
*	*	WILLIAMSON	917	736

STA.	TO STA.
FED. ROAD DIST. NO.	ILLINOIS FED. AID PROJECT

* I-57, & OLD IL 13 (FAU 9629)
 ** (X1-6-2)VB-2,(X1-6)HKB-2

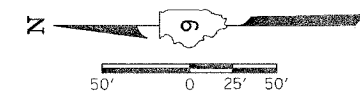
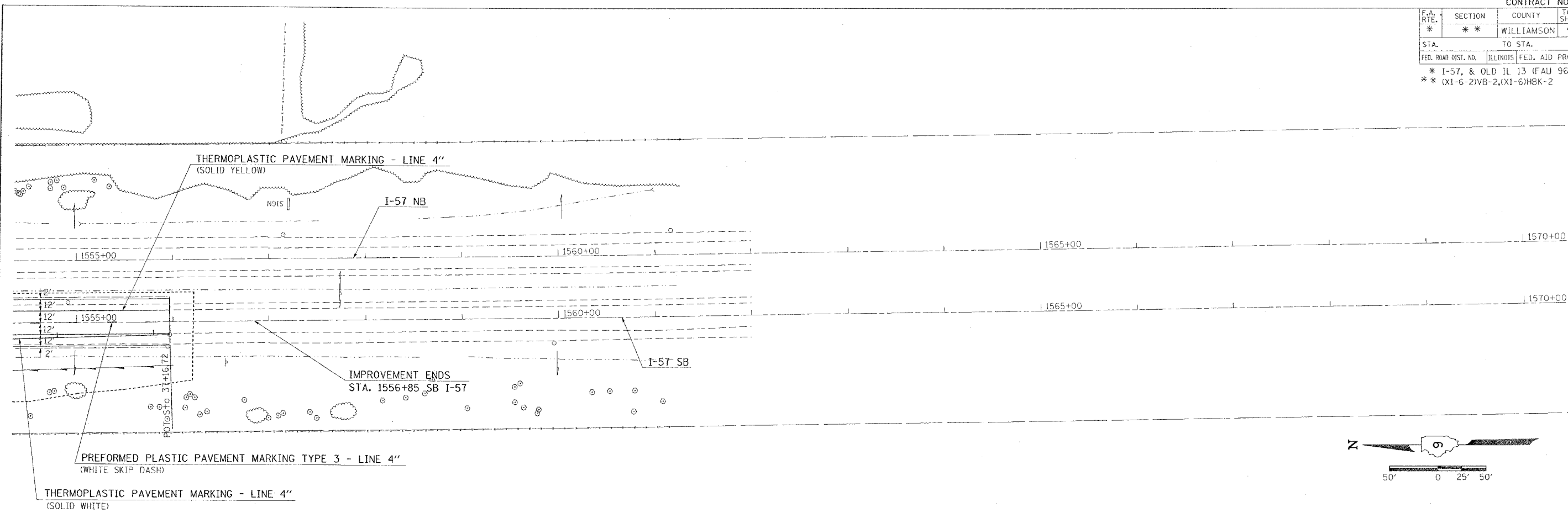

PLOT DATE = 10/17/2006
 FILE NAME = I:\98950\98950.dwg
 PLOT SCALE = 1/8" = 1'-0"
 USER NAME = heaton

REVISIONS	
NAME	DATE

ILLINOIS DEPARTMENT OF TRANSPORTATION

PAVEMENT MARKINGS

I-57

STA. 1555+00 TO STA. 1560+00

SCALE: VERT. 50
 HORIZ. 1" = 100'

DATE: _____ DRAWN BY CNH
 CHECKED BY _____

F.A. RTE.	SECTION	COUNTY	TOTAL SHEETS NO.	SHEET NO.
*	*	WILLIAMSON	917	737
STA.	TO STA.			
FED. ROAD DIST. NO.	ILLINOIS	FED. AID PROJECT		
* I-57, & OLD IL 13 (FAU 9629)				
** (X1-6-2)VB-2, (X1-6)HBK-2				

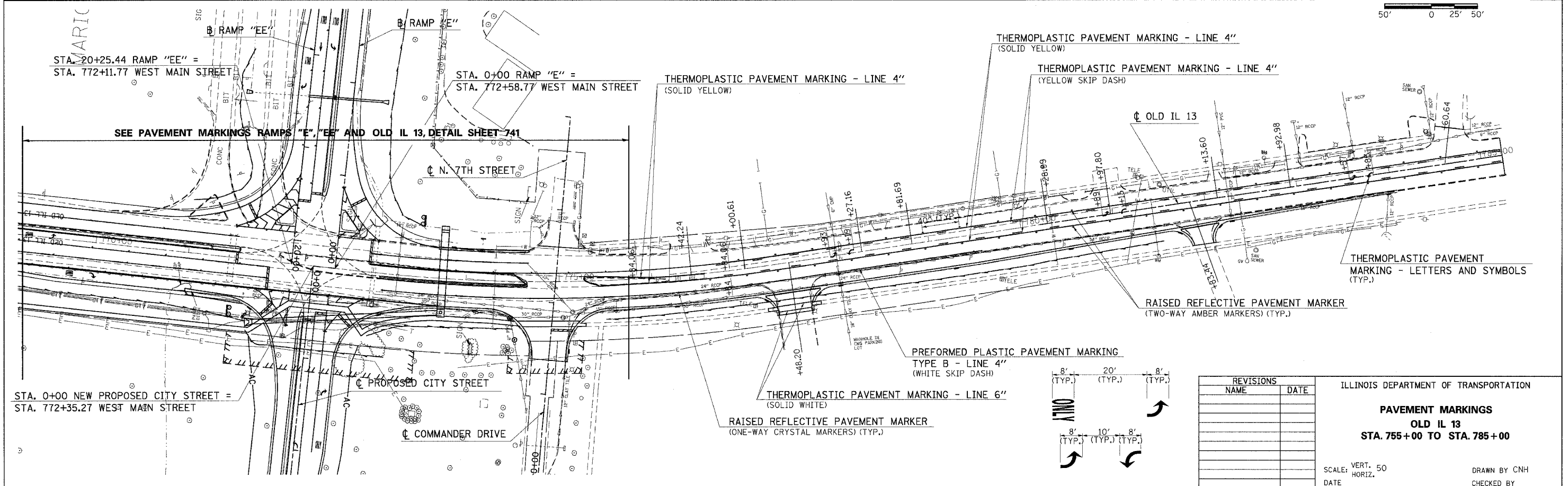
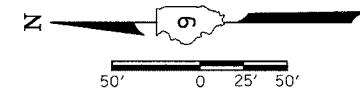
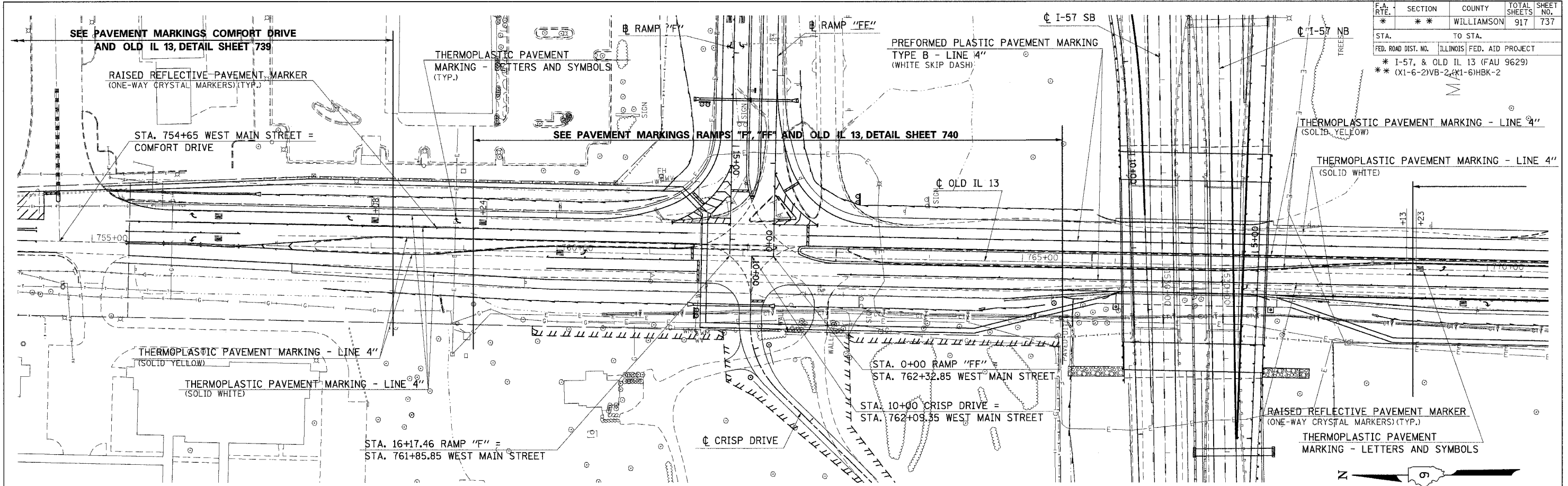

PLOT DATE = 12/16/2006
 FILE NAME = c:\pvc\pvc\pvc\98950\98950.dwg
 PLOT SCALE = 1/8" = 1'-0"
 USER NAME = hester

REVISIONS	
NAME	DATE

ILLINOIS DEPARTMENT OF TRANSPORTATION

PAVEMENT MARKINGS

OLD IL 13

STA. 755+00 TO STA. 785+00

SCALE: VERT. 50
DATE HORIZ.

DRAWN BY CNH
CHECKED BY

F.A. RTE.	SECTION	COUNTY	TOTAL SHEETS	SHEET NO.
*	*	WILLIAMSON	917	738

STA. TO STA.
FED. ROAD DIST. NO. ILLINOIS FED. AID PROJECT

* I-57, & OLD IL 13 (FAU 9629)
** (X1-6-2)VB-2, (X1-6)HBK-2

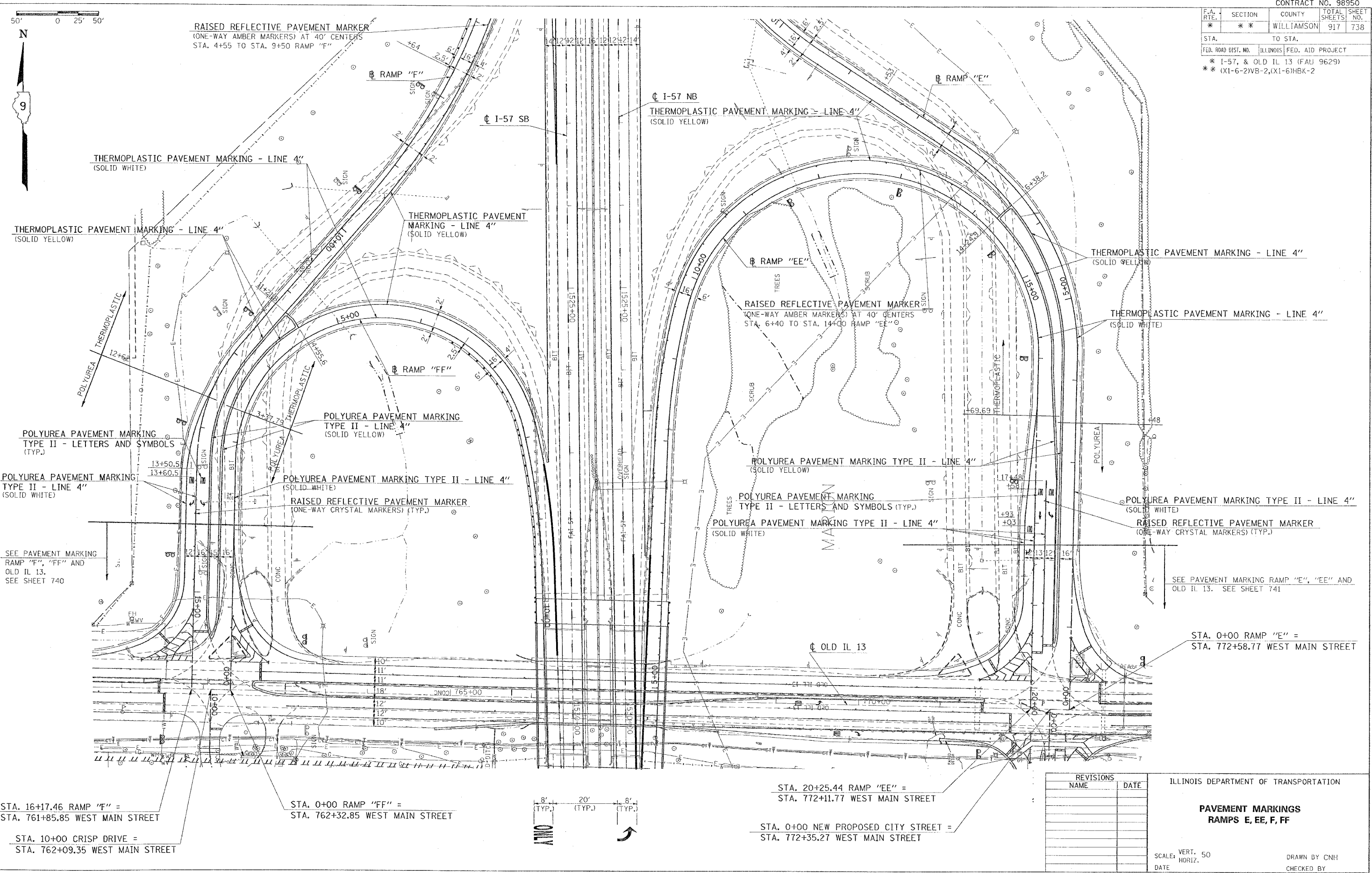

STA. 16+17.46 RAMP "F" =
STA. 761+85.85 WEST MAIN STREET

STA. 10+00 CRISP DRIVE =
STA. 762+09.35 WEST MAIN STREET

STA. 0+00 RAMP "FF" =
STA. 762+32.85 WEST MAIN STREET

STA. 20+25.44 RAMP "EE" =
STA. 772+11.77 WEST MAIN STREET

STA. 0+00 NEW PROPOSED CITY STREET =
STA. 772+35.27 WEST MAIN STREET

STA. 0+00 RAMP "E" =
STA. 772+58.77 WEST MAIN STREET

REVISIONS	
NAME	DATE

ILLINOIS DEPARTMENT OF TRANSPORTATION

**PAVEMENT MARKINGS
RAMPS E, EE, F, FF**

SCALE: VERT. 50
HORIZ. DATE

DRAWN BY CNH
CHECKED BY

PLOT DATE: 10/13/2006
 FILE NAME: N:\98950\98950.dwg
 PLOT SCALE: 1/8" = 1'-0"
 USER NAME: J. Neeson

F.A. RTE.	SECTION	COUNTY	TOTAL SHEETS	SHEET NO.
*	**	WILLIAMSON	917	739
STA. TO STA.				
FED. ROAD DIST. NO. ILLINOIS FED. AID PROJECT				
* I-57, & OLD IL 13 (FAU 9629)				
** (X1-6-2)VB-2,(X1-6)HBK-2				

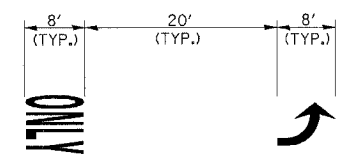
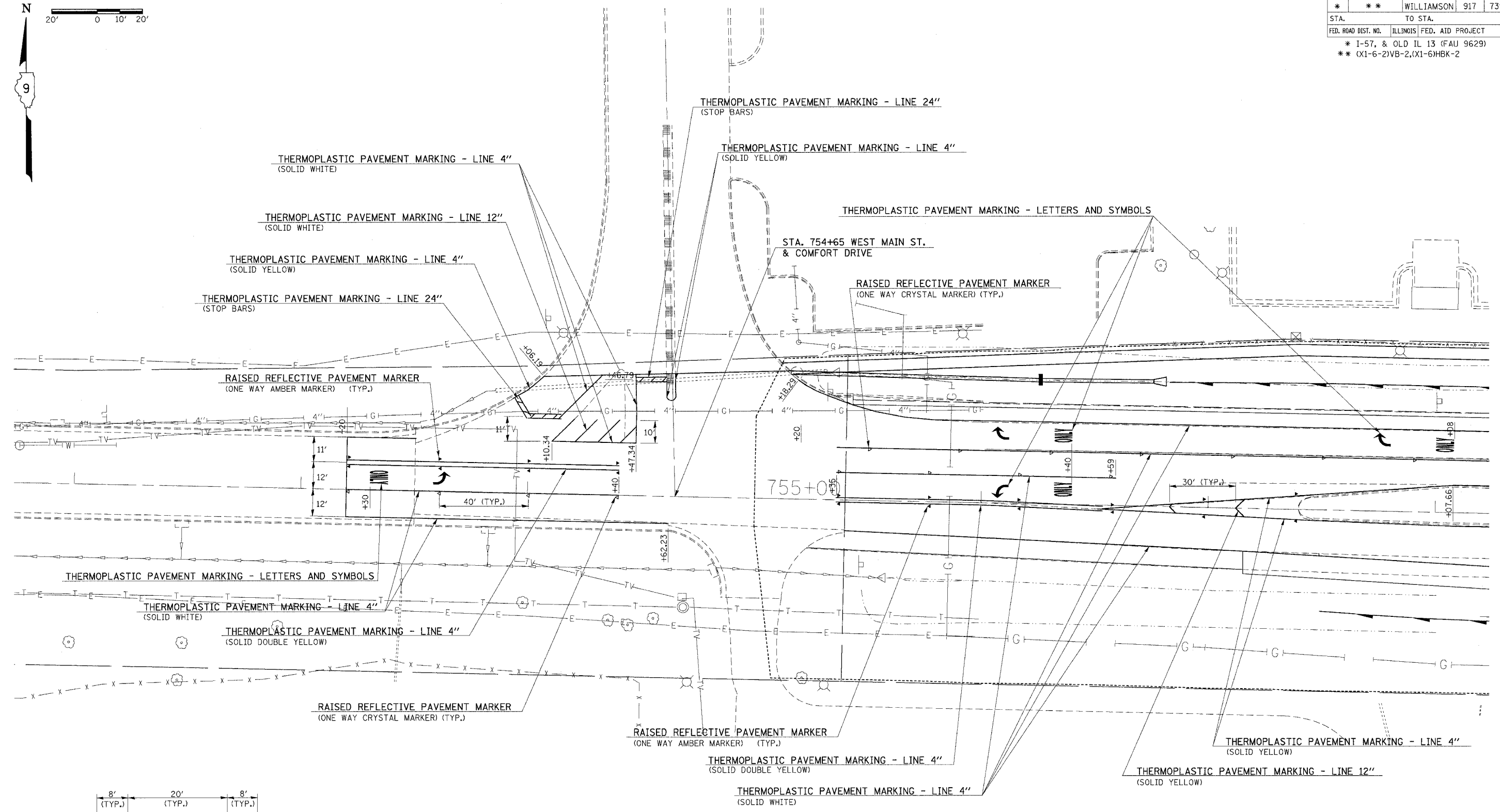
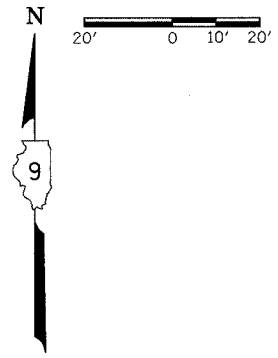

PLOT DATE = 12/16/2006
 FILE NAME = c:\pcc\projects\982802\old13\old13p4.dgn
 PLOT SCALE = 20.0000 / IN.
 USER NAME = heaton

REVISIONS	
NAME	DATE

ILLINOIS DEPARTMENT OF TRANSPORTATION

PAVEMENT MARKING
OLD IL 13 AND COMFORT DRIVE

SCALE: VERT. 20
DATE: HORIZ.

DRAWN BY CNH
CHECKED BY

F.A. RTE.	SECTION	COUNTY	TOTAL SHEETS	SHEET NO.
*	**	WILLIAMSON	917	740
STA.		TO STA.		
FED. ROAD DIST. NO.		ILLINOIS	FED. AID PROJECT	
* I-57, & OLD IL 13 (FAU 9629)				
** (X1-6-2)VB-2,(X1-6)HKB-2				

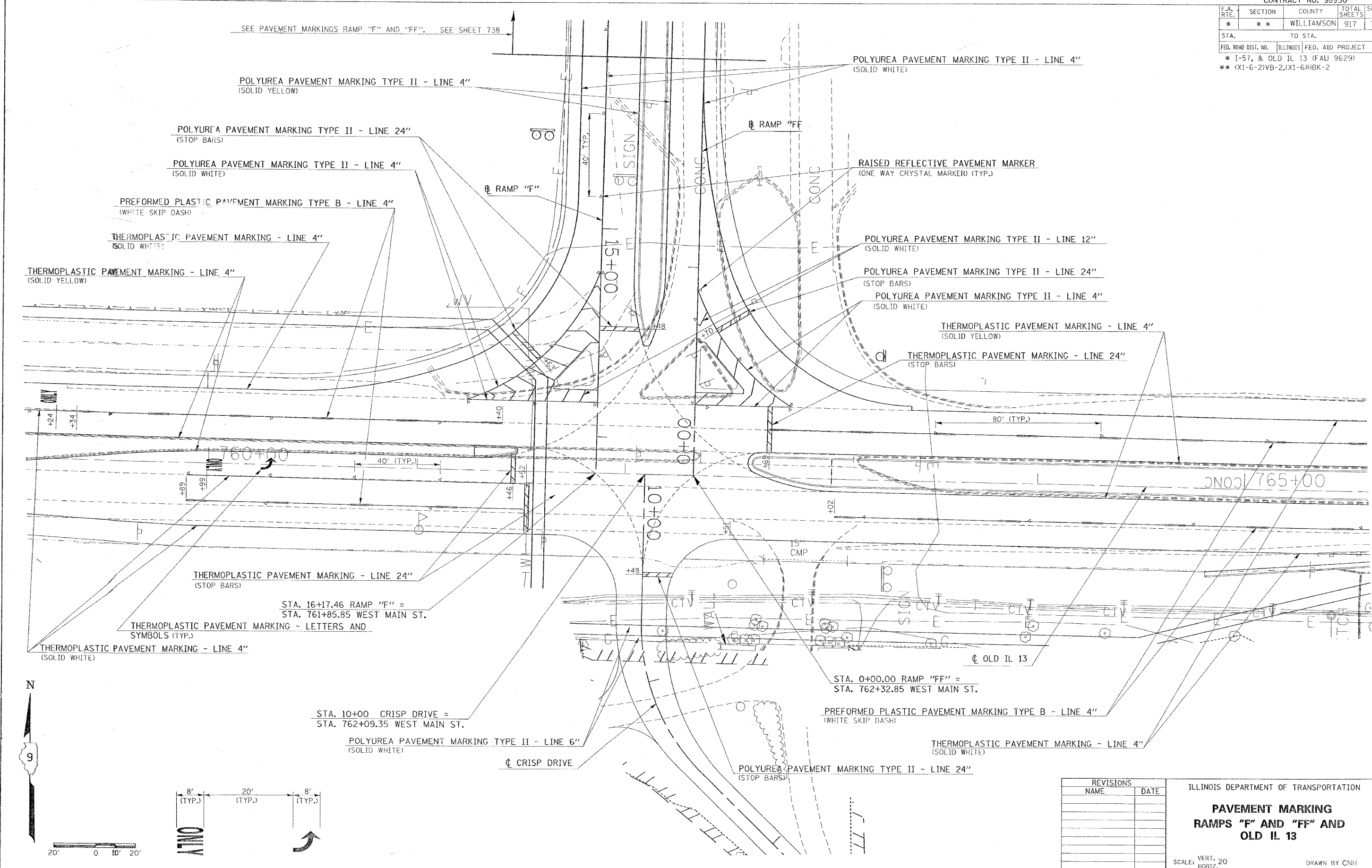

REVISIONS	
NAME	DATE

ILLINOIS DEPARTMENT OF TRANSPORTATION
**PAVEMENT MARKING
 RAMPS "F" AND "FF" AND
 OLD IL 13**

SCALE: VERT. 20
 DATE: HORIZ.
 DRAWN BY CNH
 CHECKED BY

PLOT DATE = 02/13/2008
 FILE NAME = c:\pwork\pav\p92822\oldil13\p92822.dgn
 PLOT SCALE = 20.0000 1" = 20'
 USER NAME = neason

F.A. RTE.	SECTION	COUNTY	TOTAL SHEETS	SHEET NO.
*	**	WILLIAMSON	917	741
STA.		TO STA.		
FED. ROAD DIST. NO.		ILLINOIS FED. AID PROJECT		
* I-57, & OLD IL 13 (FAU 9629)				
** (X1-6-2)VB-2,(X1-6)HBK-2				

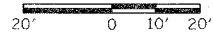
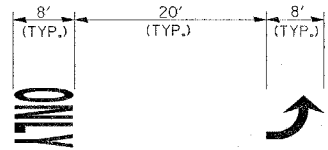
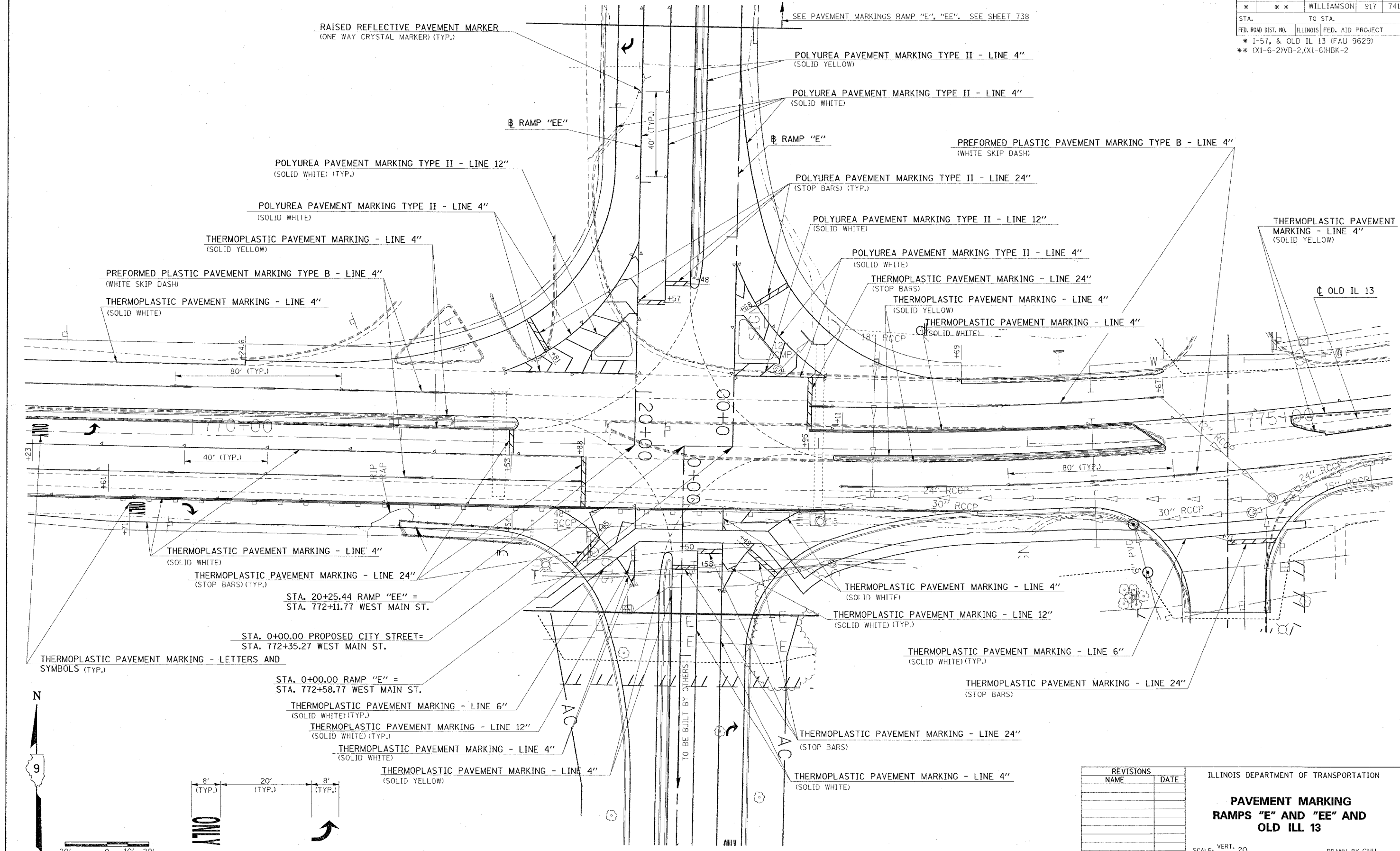

REVISIONS	
NAME	DATE

ILLINOIS DEPARTMENT OF TRANSPORTATION

**PAVEMENT MARKING
RAMPS "E" AND "EE" AND
OLD ILL 13**

SCALE: VERT. 20
HORIZ. 20

DATE _____ DRAWN BY CNH
CHECKED BY _____

Plot Date = 11/21/2006
File Name = c:\pavement\98950\pavement\98950.dgn
User Name = R. H. ...

F.A. RTE.	SECTION	COUNTY	TOTAL SHEETS	SHEET NO.
*	**	WILLIAMSON	917	742
STA. TO STA.				
FED. ROAD DIST. NO.			ILLINOIS FED. AID PROJECT	
* I-57, & OLD IL 13 (FAU 9629)				
** (X1-6-2)VB-2,(X1-6)HBK-2				

Structure Number	Station	Design Truss Type	Cantilever Length (L)	Elev. A	Dim. D	D _s	Total Sign Area
9C100105TR53.1	1515+50	II-C-A	30'	466.4	20'	9'	117

GENERAL NOTES

DESIGN: AASHTO Standard Specifications for Structural Supports for Highway Signs, Luminaires and Traffic Signals. ("AASHTO Specifications")

CONSTRUCTION: Current (at time of letting) Illinois Department of Transportation Standard Specifications for Road and Bridge Construction, Supplemental Specifications and Special Provisions. ("Standard Specifications")

LOADING: 90 M.P.H. WIND VELOCITY

WALKWAY LOADING: Dead load plus 500 lbs. concentrated live load.

DESIGN STRESSES:
Field Units
f_c = 3,500 p.s.i.
f_y = 60,000 p.s.i. (reinforcement)

WELDING: All welds to be continuous unless otherwise shown. All welding to be done in accordance with current AWS D1.1 and D1.2 Structural Welding Codes (Steel and Aluminum) and the Standard Specifications.

MATERIALS: Aluminum Alloys as shown throughout plans. All Structural Steel Pipe shall be ASTM A53 Grade B with a minimum yield of 35,000 p.s.i., or A500 Grade B or C with a minimum yield of 46,000 p.s.i. If A500 pipe is substituted for A53, then the outside diameter shall be as detailed and wall thickness greater than or equal to A53.

All Structural Steel Plates and Shapes shall conform to AASHTO M270 Gr. 36, Gr. 50 or Gr. 50W*. Stainless steel for shims, sleeves and handhole covers shall be ASTM A240, Type 302 or 304, or another alloy suitable for exterior exposure and acceptable to the Engineer.

The steel pipe and stiffening ribs at the base plate for the column shall have a minimum longitudinal Charpy V-Notch (CVN) energy of 15 lb.-ft. at 40° F. (Zone 2) before galvanizing.

FASTENERS FOR ALUMINUM TRUSSES: All bolts noted as "high strength" must satisfy the requirements of AASHTO M164 (ASTM A325), or approved alternate, and must have matching lock nuts. Threaded studs for splices (if Members interfere) must satisfy the requirements of ASTM A449, ASTM A193, Grade B7, or approved alternate, and must have matching lock nuts. Bolts and lock nuts not required to be high strength must satisfy the requirements of ASTM A307. All bolts and lock nuts must be hot dip galvanized per AASHTO M232. The lock nuts must have nylon or steel inserts. A stainless steel flat washer conforming to ASTM A240 Type 302 or 304, is required under both head and nut or under both nuts where threaded studs are used. High strength bolt installation shall conform to Article 505.04 (f) (2) of the IDOT Standard Specifications for Road and Bridge Construction. Rotational capacity ("ROCAP") testing of bolts will not be required.

U-BOLTS AND EYEBOLTS: U-Bolts and Eyebolts must be produced from ASTM A276 Type 304, 304L, 316 or 316L, Condition A, cold finished stainless steel, or an equivalent material acceptable to the Engineer. All nuts for U-Bolts and Eyebolts must be lock nuts equivalent to ASTM A307 with nylon or steel inserts and hot dip galvanized per AASHTO M232. A stainless steel flat washer conforming to ASTM A240, Type 302 or 304, is required under each U-Bolt and Eyebolt lock nut.

GALVANIZING: All Steel Grating, Plates, Shapes and Pipe shall be Hot Dip Galvanized after fabrication in accordance with AASHTO M111. Painting is not permitted.

ANCHOR RODS: Shall conform to AASHTO M314 Gr. 55 with a minimum Charpy V-Notch (CVN) energy of 15 lb.-ft. at 10° F.

CONCRETE SURFACES: All concrete surfaces above an elevation 6" below the lowest final ground line at each foundation shall be cleaned and coated with Bridge Seat Sealer in accordance with the Standard Specifications.

REINFORCEMENT BARS: Reinforcement Bars designated (E) shall be epoxy coated in accordance with the Standard Specifications.

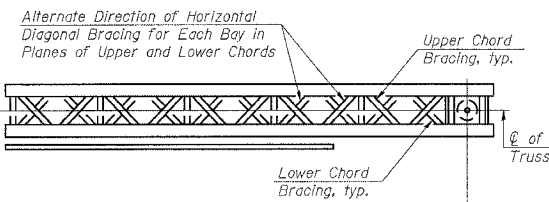

TYPICAL PLAN
(Walkway not shown)

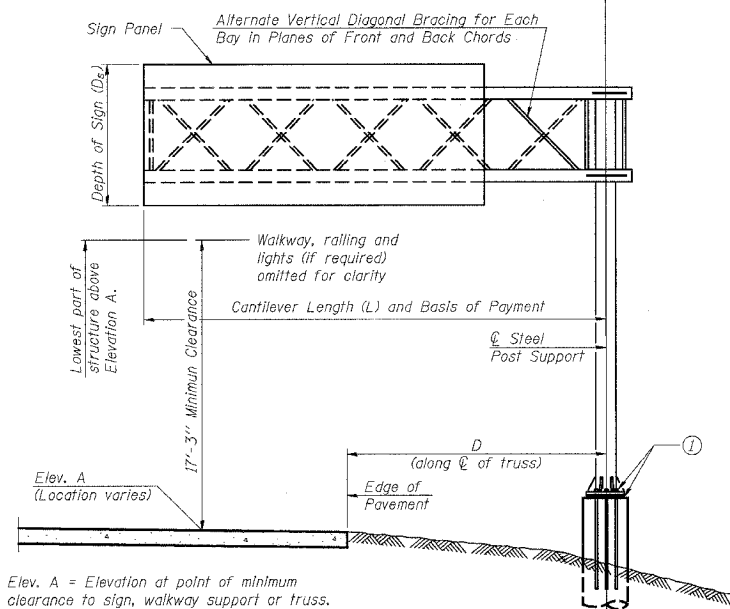

Elev. A = Elevation at point of minimum clearance to sign, walkway support or truss.

TYPICAL ELEVATION
Looking in Direction of Traffic

Sign support structures may be subject to damaging vibrations and oscillations when sign panels are not in place during erection or maintenance of the structure. To avoid these vibrations and oscillations, consideration should be given to attaching temporary blank sign panels to the structure.

Truss Type	Maximum Sign Area	Maximum Length
I-C-A	170 Sq. Ft.	25 Ft.
II-C-A	340 Sq. Ft.	30 Ft.
III-C-A	400 Sq. Ft.	40 Ft.

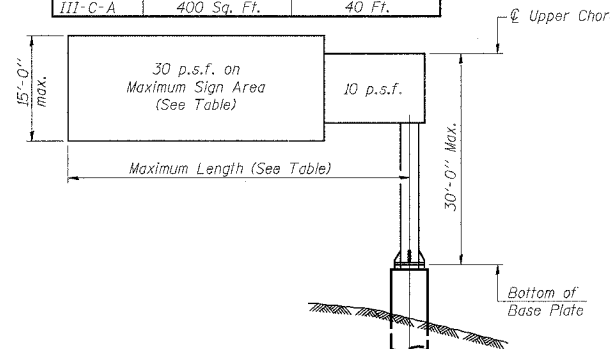

DESIGN WIND LOADING DIAGRAM

Parameters shown are basis for I.D.O.T. Standards. Installations not within dimensional limits shown require special analysis for all components.

① After adjustments to level truss and insure adequate vertical clearance, all top and leveling nuts shall be tightened against the base plate with a minimum torque of 200 lb.-ft. Stainless steel mesh shall then be placed around the perimeter of the base plate. Secure to base plate with stainless steel banding.

Note: Trusses shall be shipped individually with adequate provision to prevent detrimental motion during transport. This may require ropes between horizontals and diagonals or energy dissipating (elastic) ties to the vehicle. The contractor is responsible for maintaining the configuration and protection of the trusses.

* If M270 Gr. 50W (M222) steel is proposed, chemistry for plate to be used shall first be approved by the Engineer as suitable for galvanizing and welding.

TOTAL BILL OF MATERIAL

ITEM	UNIT	TOTAL
OVERHEAD SIGN STRUCTURE CANTILEVER TYPE II-C-A	Foot	30
OVERHEAD SIGN STRUCTURE WALKWAY, TYPE A	Foot	14
DRILLED SHAFT CONCRETE FOUNDATIONS	Cu. Yds.	6.9

NUMBER	REVISION	DATE

REVISIONS		ILLINOIS DEPARTMENT OF TRANSPORTATION
NAME	DATE	
		CANTILEVER SIGN STRUCTURES GENERAL PLAN & ELEVATION ALUMINUM TRUSS & STEEL POST

SCALE: VERT. NONE
HORIZ.
DATE
DRAWN BY CNH
CHECKED BY

OSC-A-1 1-7-05

F.A. RTE.	SECTION	COUNTY	TOTAL SHEETS	SHEET NO.
*	**	WILLIAMSON	917	743
STA.		TO STA.		
FED. ROAD DIST. NO.		ILLINOIS	FED. AID PROJECT	
		* I-57, & OLD IL 13 (FAU 9629)		
		** (X1-6-2)VB-2,(X1-6)HBK-2		

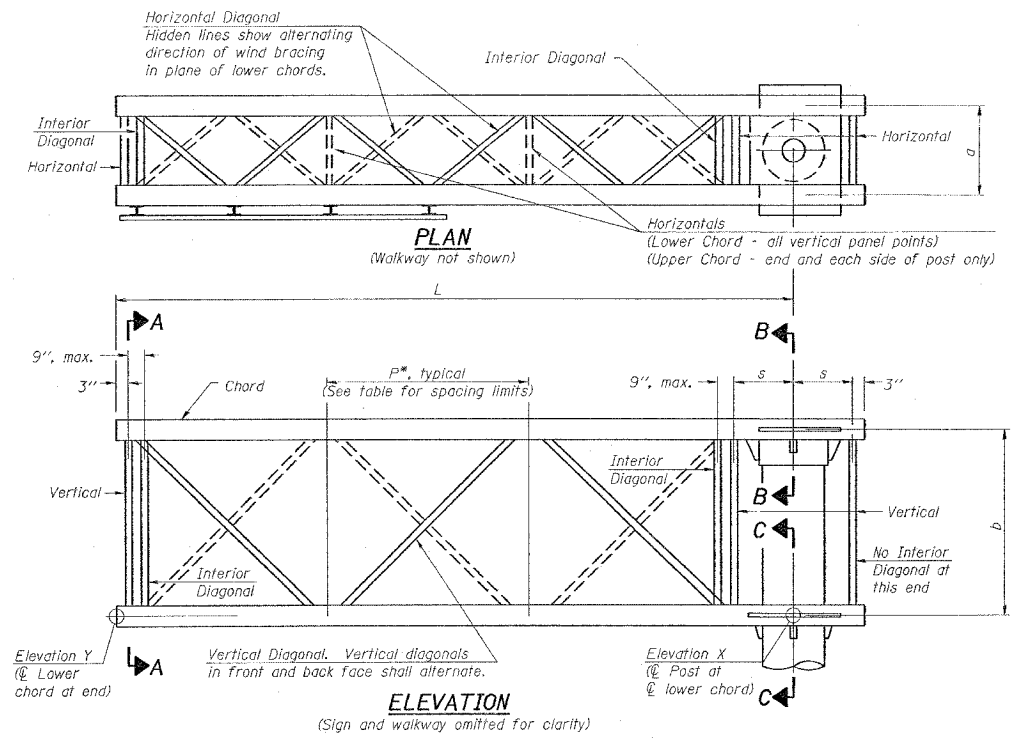

TYPICAL TRUSS UNIT

Note:
There are twice as many horizontal diagonals as there are vertical diagonals.

For Section B-B and Section C-C, see Base Sheet OSC-A-3.

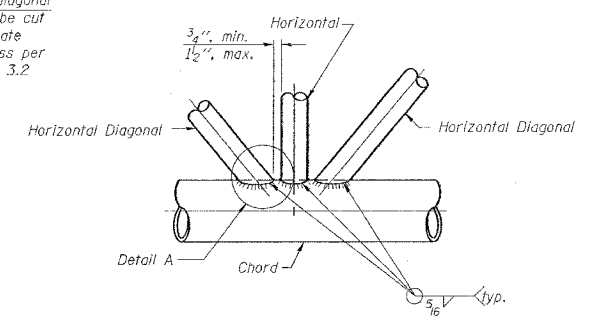
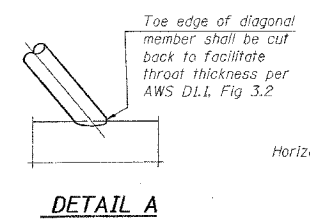
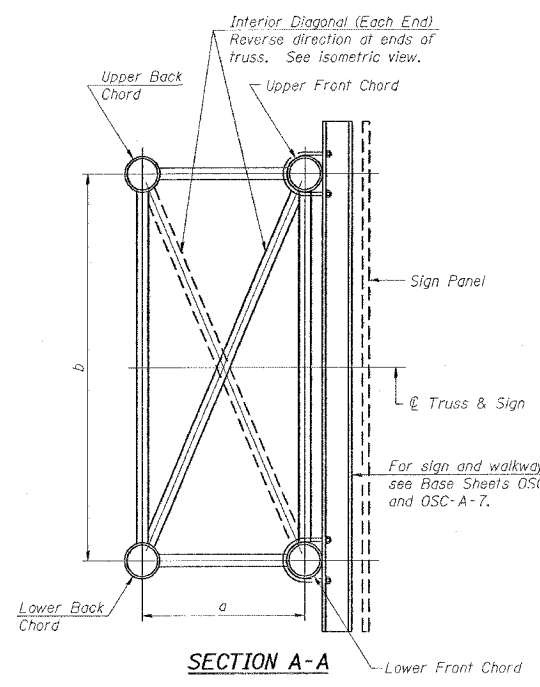

Structure Number	Station	Truss Type	Design Length (L)	Number of Panels Per Unit	Panel Length (P)*
9C1001057R53.1	1515+50	II-C-A	30'	7	4

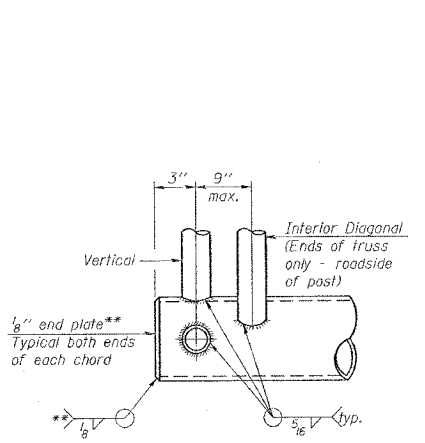

** Contractor may alternatively use standard aluminum drive-fit cap to close ends.

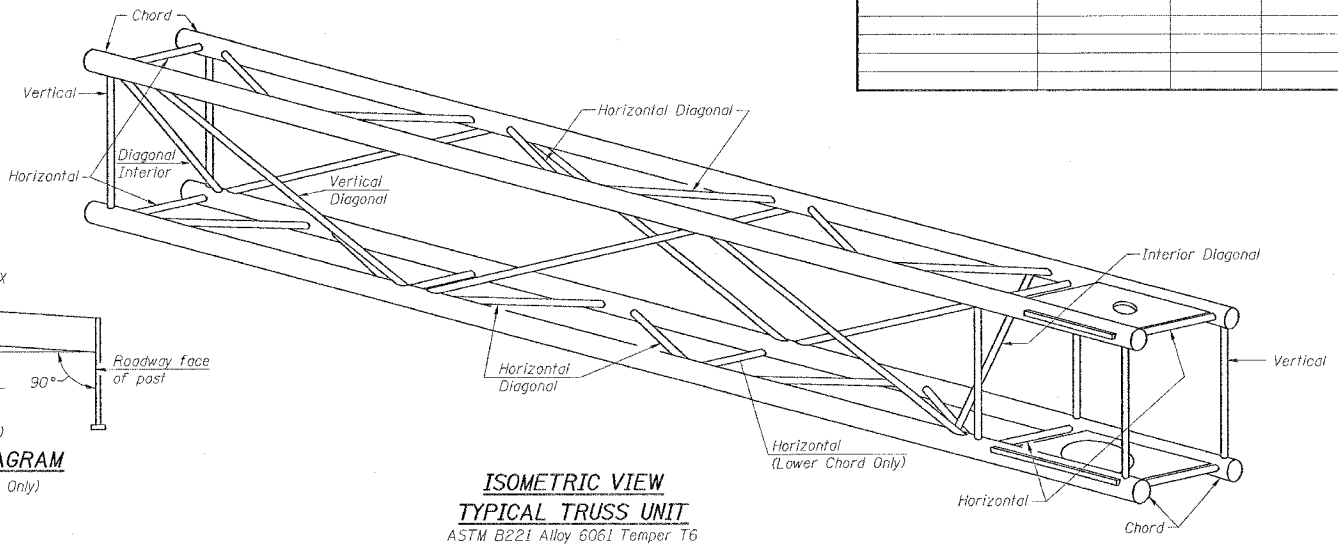
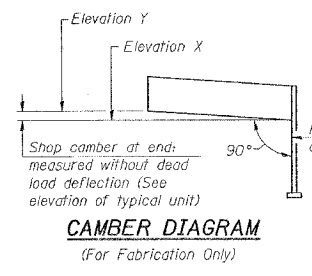
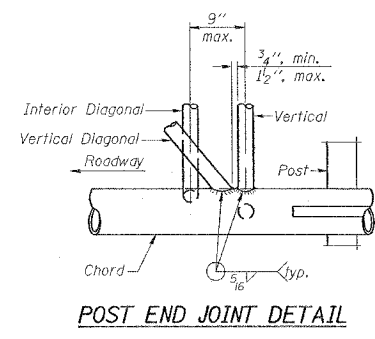

SHOP CAMBER TABLE

Unit Length (L)	Shop Camber at End
15'	1 1/2"
16'-17'	1 3/4"
18'-20'	2"
21'-22'	2 1/4"
23'-25'	2 1/2"
26'-27'	2 3/4"
28'-30'	3"
31'-32'	3 1/4"
33'-35'	3 1/2"
36'-37'	4"
38'-40'	4 1/2"

TRUSS UNIT TABLE

Truss Type	Dimension "a"	Dimension "b"	Dimension "s"	Limits for Panel Spacing (P)*	Up. & Low. Chord			
					O.D.	Wall	O.D.	Wall
I-C-A	24"	54"	16"	36" min. to 48" max.	5"	5/16"	2 1/2"	5/16"
II-C-A	36"	66"	21"	42" min. to 54" max.	6 1/2"	5/16"	3 1/4"	5/16"
III-C-A (35' Max.)	36"	84"	21"	48" min. to 66" max.	7"	3/8"	3 1/2"	3/8"
III-C-A (>35' to 40')	36"	84"	21"	48" min. to 66" max.	8"	3/8"	3 1/2"	3/8"

*P = (L - s) / # Panels

NUMBER	REVISION	DATE

REVISIONS	
NAME	DATE

ILLINOIS DEPARTMENT OF TRANSPORTATION
CANTILEVER SIGN STRUCTURES TRUSS DETAILS
ALUMINUM TRUSS & STEEL POST

SCALE: VERT. NONE
HORIZ. DATE
DRAWN BY CNH
CHECKED BY

PLOT DATE: 10/12/2006
 FILE NAME: c:\p3\sc\osc-a-2\osc-a-2.dwg
 USER: NAME
 PLOTTER: HP DesignJet 500 / 24

F.A. RTE.	SECTION	COUNTY	TOTAL SHEETS	SHEET NO.
**	**	WILLIAMSON	917	744
STA. TO STA.				
FED. RD. DIST. NO. ILLINOIS FED. AID PROJECT				
* I-57, & OLD IL 13 (FAU 9629)				
** (X1-6-2)WB-2,(X1-6)HBK-2				

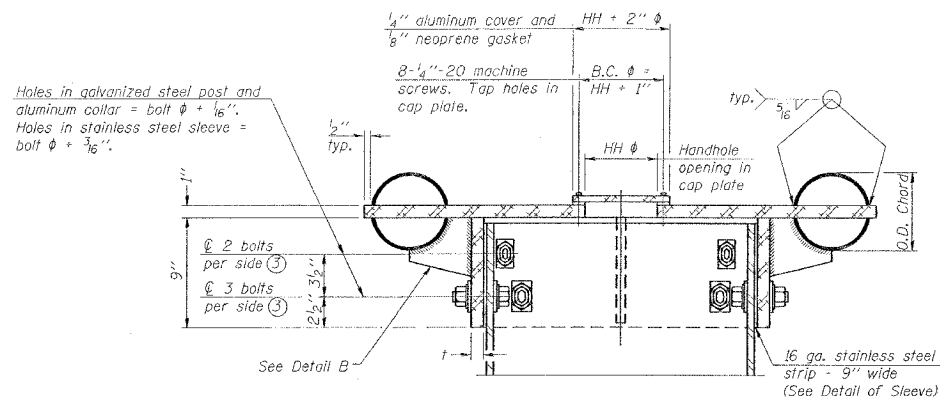

SECTION B-B

Bolts, washers (including contoured washers), and locknuts shall be stainless steel.

- Collar I.D. shall be manufactured to correspond to O.D. of actual galvanized post and stainless steel sleeve plus 1/8" (+1/16"). Maximum gap between post and collar at any location equals 1/8" before tightening bolts.

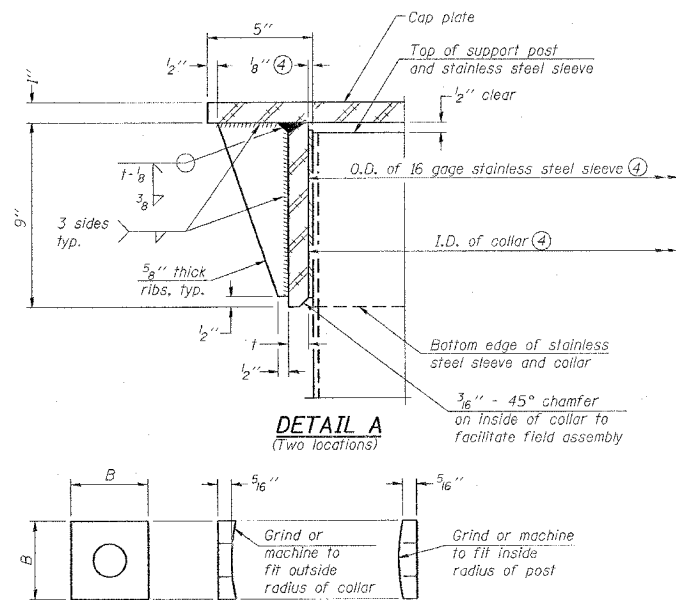

DETAIL A (Two locations)

CONTOURED WASHERS

Bolt Size	Contoured Washers Hole Dia.	B
1/8"	1"	2 1/2"
1"	1 1/8"	3"
1 1/4"	1 3/8"	3 1/4"

NUMBER	REVISION	DATE

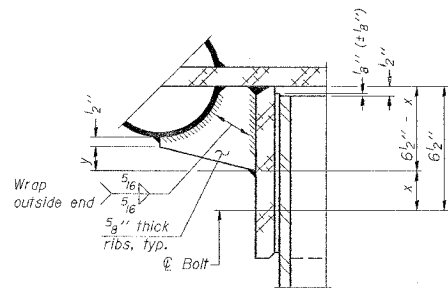

DETAIL B

Two locations (For details not shown, see Detail C)

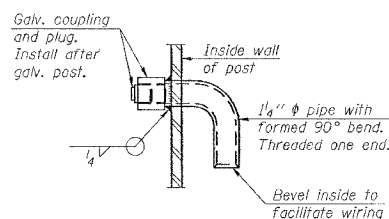

DETAIL D

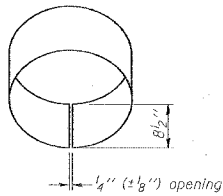

DETAIL OF STAINLESS STEEL SLEEVE

Weld to post after galvanizing. (Prepare post surface to insure tight, uniform fit and allow welding.) Welds to be 1/2" long at 6" o/s. along top edge and at 1/4" opening.

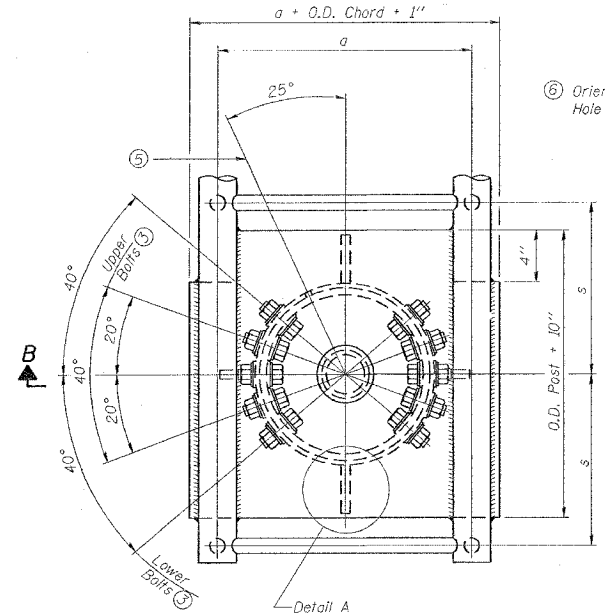

PLAN VIEW - TOP OF COLUMN

5 Optional full penetration weld in collar. (Two locations maximum... (180 degrees apart)... X-ray or UT 100%)

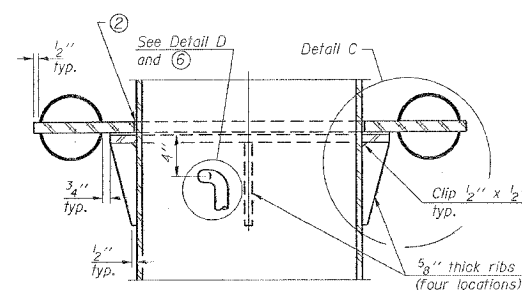

SECTION C-C

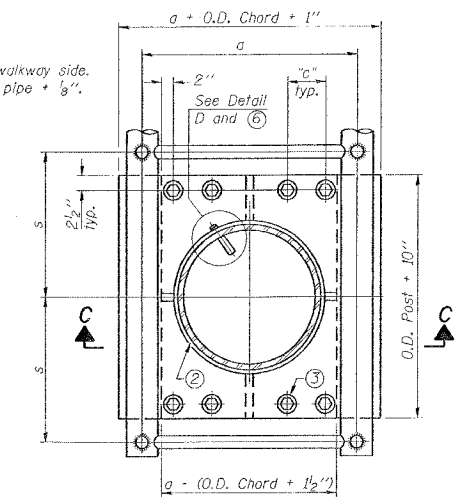

SECTION THRU POST ABOVE LOWER CHORDS

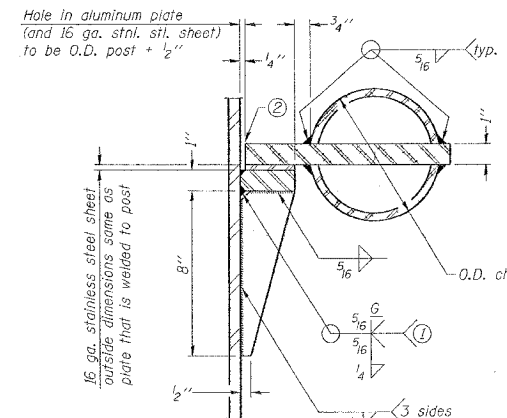

DETAIL C

- Grind top if required to fully seat aluminum plate and stainless steel sheet.
- After tightening lower connection bolts, fill gap with non-hardening, silicone caulk suitable for exterior exposure and acceptable to the Engineer. Cost is included in Overhead Sign Structure Cantilever.

Truss Type	Post Size	Upper & Lower Connection Bolt Diameter (3)	Lower Juncture Bolt Spacing Dimension "c" (3)	Opening in Cap Plate "HH"	Collar Thickness (t)	Side Ribs	
						x	y
I-C-A	16" # (B3#1/)	7/8"	3 1/4"	8"	5/8"	1 3/4"	2 1/4"
II-C-A	24" # (I25#1/)	1"	3 1/2"	12"	7/8"	2"	1 1/4"
III-C-A (35' max.)	24" # (I25#1/)	1 1/4"	3 1/2"	12"	7/8"	2"	1"
III-C-A (35' to 40')	24" # (I71#1/)	1 1/4"	3 1/2"	12"	7/8"	2"	1"

- Upper and lower connection bolts in collar and bolts at lower chord connection shall be high strength with matching locknuts. Connection bolts shall have 2 stainless steel flat washers each.

REVISIONS	
NAME	DATE

ILLINOIS DEPARTMENT OF TRANSPORTATION
**CANTILEVER SIGN STRUCTURES
 JUNCTURE DETAILS
 ALUMINUM TRUSS & STEEL POST**

SCALE: VERT. NONE
 HORIZ.
 DATE
 DRAWN BY CNH
 CHECKED BY

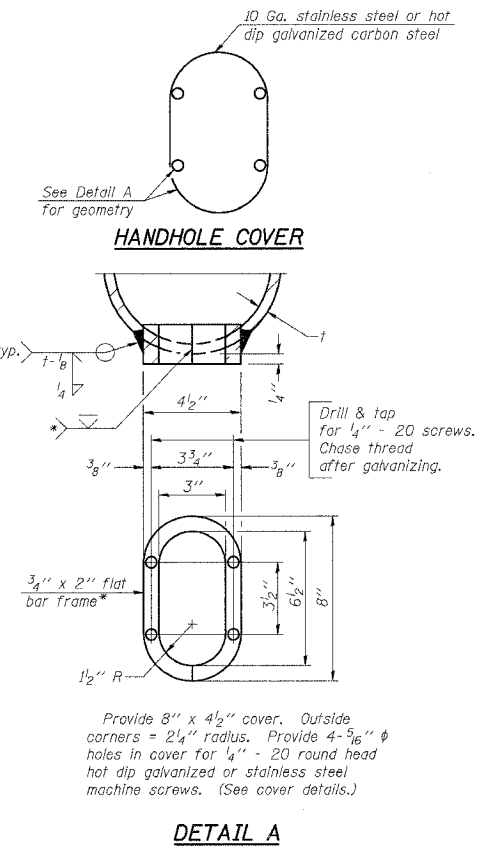
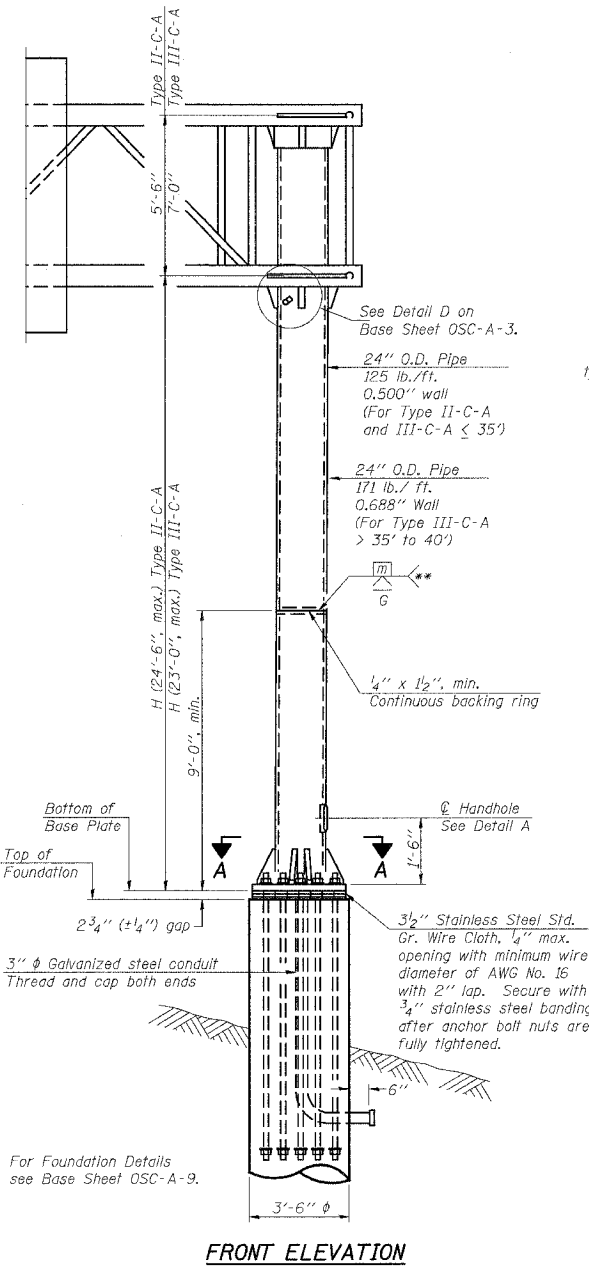
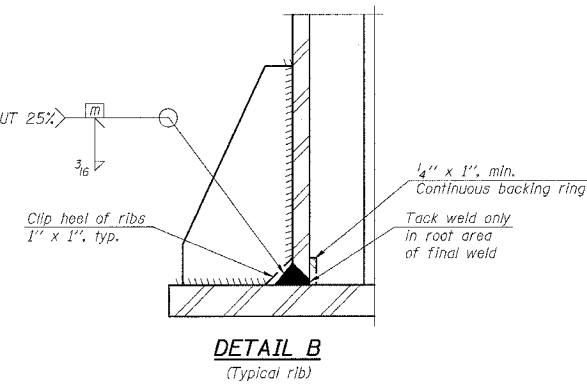
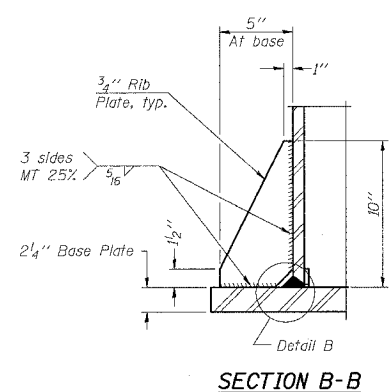
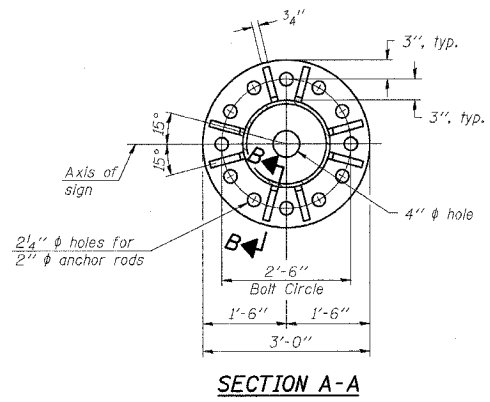

DETAIL A

* Bent bars may be butt welded top and bottom or bottom only. In lieu of fabricated handhole frame as shown, may cut from 2" plate (rolling direction vertical). All cut faces to be ground to ANSI Roughness of 500 μin or less.

** Butt welded joint in post is only allowed for post heights (H) over 20 ft. in length. If used, weld procedure must be preapproved by Engineer and joint shall receive 100% RT or UT (tension criteria) at Contractor's expense.

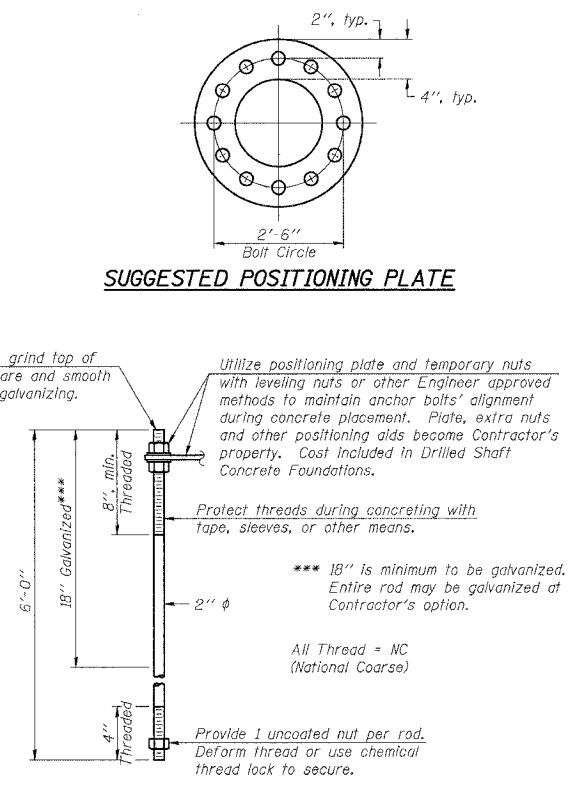
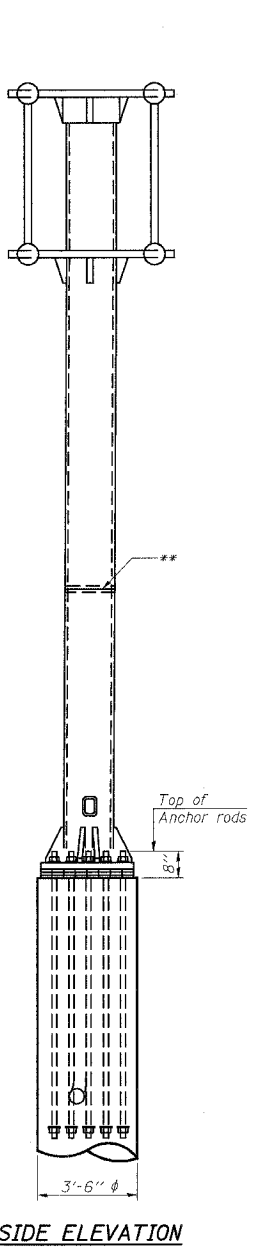

ANCHOR ROD DETAIL

Anchor rods shall conform to AASHTO M314 Grade 55 and meet Charpy V-Notch (CVN) energy of 15 lb.-ft. at 10° F. before galvanizing. Galvanize the upper 18" (minimum***) and associated M291, Grade A, C or DH heavy hex nuts and hardened washers per AASHTO M232. No welding shall be permitted on rods. Provide an unfinished nut at bottom, a hexagon locknut and washer above base plate and a leveling nut and washer below base plate. Nuts shall each be tightened with 200 lb.-ft. minimum torque against base plate. Before or after threading, but before galvanizing, each anchor rod shall be ultrasonically tested (UT) by a Level II or III inspector, qualified in accord with ANSI guidelines, using a straight beam, 1/2" φ 3.5 mhz. transducer, to insure no rejectable flaws exist in the upper 18" (tension criteria). Cost of testing included in Drilled Shaft Concrete Foundations.

NUMBER	REVISION	DATE

Structure Number	Station	H
9C1001057R53.1	1515+50	22.1

REVISIONS		ILLINOIS DEPARTMENT OF TRANSPORTATION
NAME	DATE	
		CANTILEVER SIGN STRUCTURES TYPE II-C-A & III-C-A TRUSS SUPPORT POST ALUMINUM TRUSS & STEEL POST

PLOT DATE = 12/13/2006
 FILE NAME = c:\pvs\res\13\92282\ad13\ad13p5.dgn
 PLOT SCALE = 50.0000 / 1 IN.
 USER NAME = headen

OSC-A-5 1-7-05

SCALE: VERT. NONE
 HORIZ.
 DATE
 DRAWN BY CNH
 CHECKED BY

F.A. RTE.	SECTION	COUNTY	TOTAL SHEETS	SHEET NO.
*	**	WILLIAMSON	917	746
STA. TO STA.				
FED. ROAD DIST. NO. ILLINOIS FED. AID PROJECT				

* I-57, & OLD IL 13 (FAU 9629)
 ** (X1-6-2)VB-2, (X1-6)HBK-2

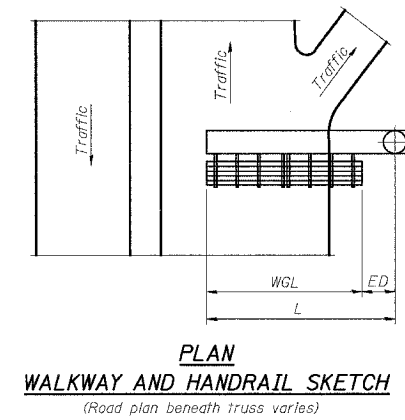
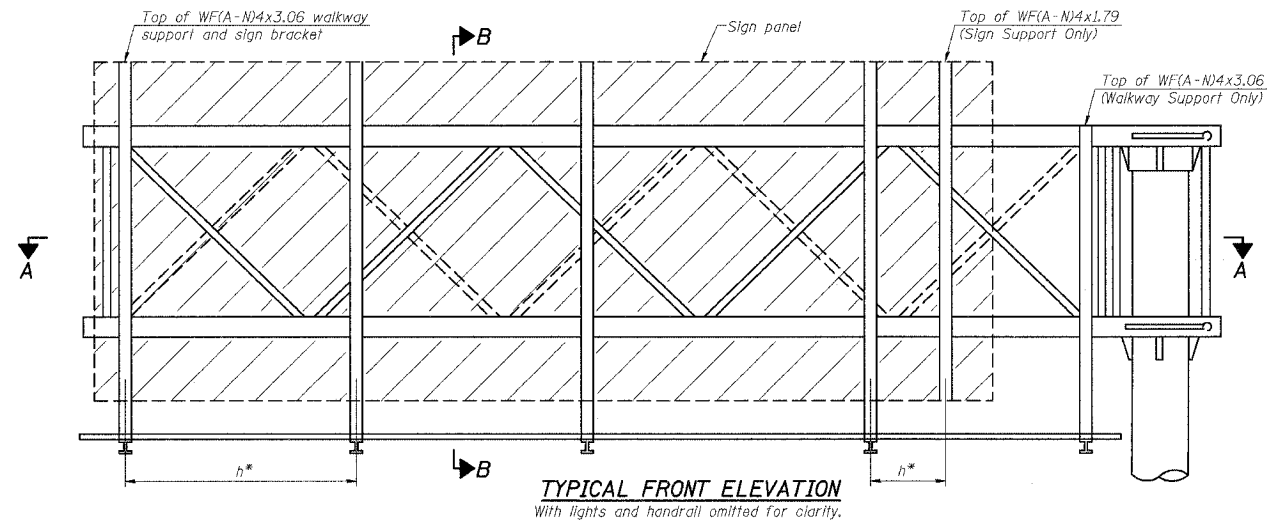

Walkway and truss grating dimensions are nominal and may vary (width ± 1/2", depth ± 1/2") based on available standard widths.

Structure Number	Station	WGL	ED	TGL
9C1001057R53.1	1515+50	14'	16'	28.5

Notes:
 * Space walkway brackets WF(A-N)4x3.06 and sign brackets WF(A-N)4x1.79 for efficiency and within limits shown.
 f = 12" maximum, 4" minimum (End of sign to center of nearest bracket)
 g = 12" maximum, 4" minimum (End of walkway to center of nearest bracket)
 h = 6'-0" maximum (center to center sign and/or walkway support brackets, WF(A-N)4x1.79 or WF(A-N)4x3.06)
 *** If walkway bracket at safety chain location is behind sign, add angle to bracket.
 For details of sign placement, sign/walkway brackets, truss and walkway gratings, grating splices and Section B-B, see Base Sheet OSC-A-7S.
 For details of handrail, handrail splice, safety chain and Details F and G, see Base Sheet OSC-A-8.

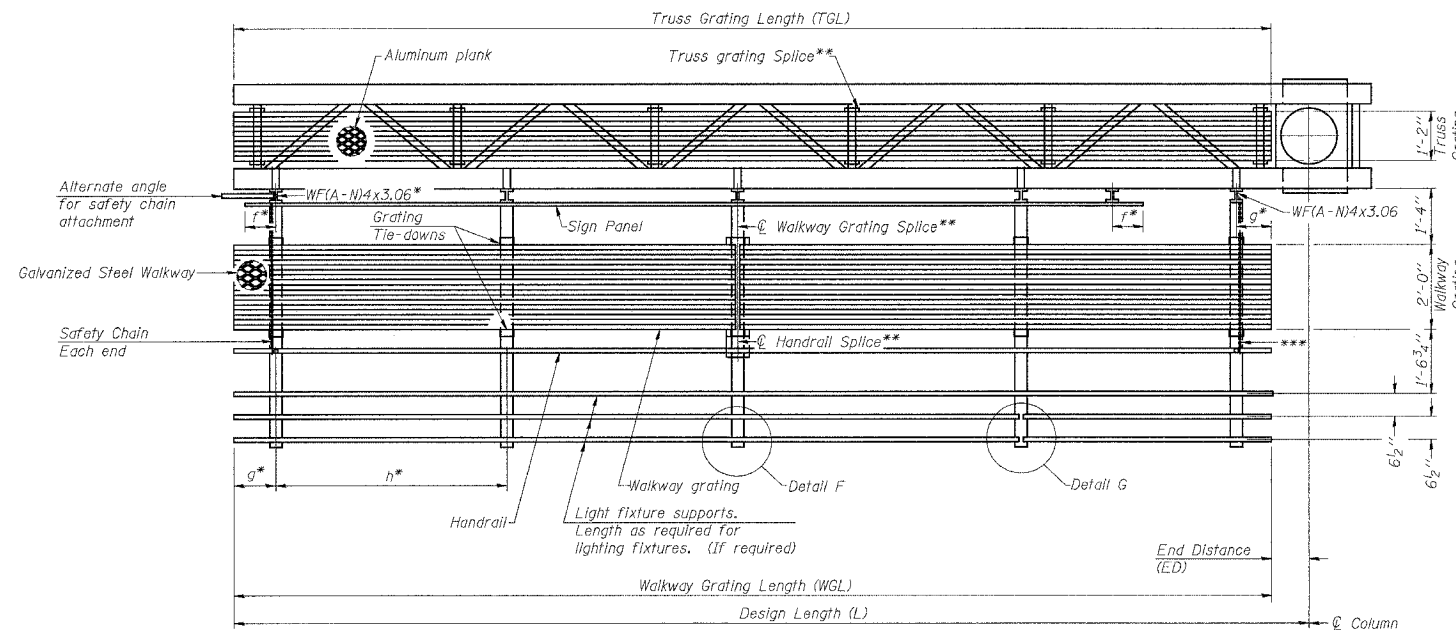

Truss grating to facilitate inspection shall run full length of cantilevers. Cost of truss grating is included in Overhead Sign Structure Cantilever.

Handrail and walkway grating shall span a minimum of three brackets between splices.
 ** Use and location of handrail or grating splices are optional, based on lengths needed and material availability.

$$TGL = L - \left(\frac{\text{Post O.D.}}{2} + 6'' \right)$$

BRACKET TABLE

Sign Width		Number Brackets Required
Greater Than	Less Than or Equal To	
8'-0"	8'-0"	2
14'-0"	14'-0"	3
20'-0"	20'-0"	4
26'-0"	26'-0"	5
32'-0"	32'-0"	6

NUMBER	REVISION	DATE

REVISIONS		ILLINOIS DEPARTMENT OF TRANSPORTATION
NAME	DATE	
		CANTILEVER SIGN STRUCTURES ALTERNATE STEEL WALKWAY DETAILS ALUMINUM TRUSS & STEEL POST

SCALE: VERT. NONE
 HORIZ. DATE
 DRAWN BY CNH
 CHECKED BY

OSC-A-6S 1-7-05

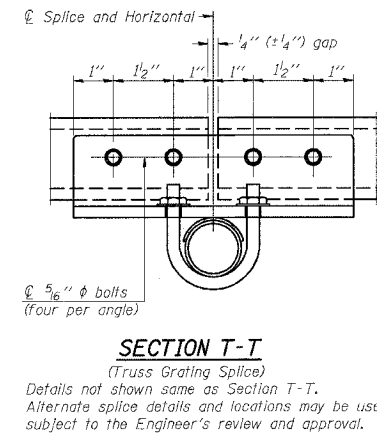
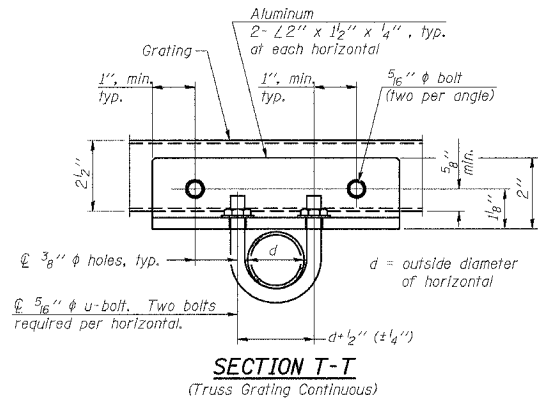
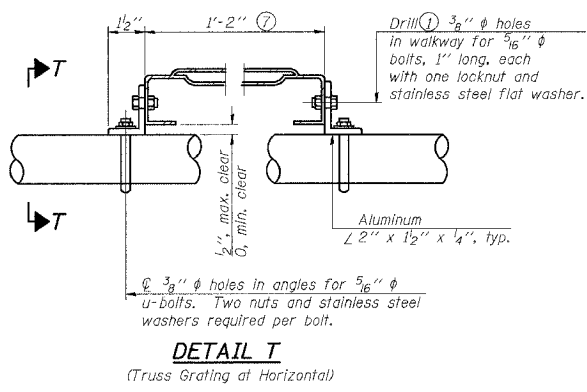
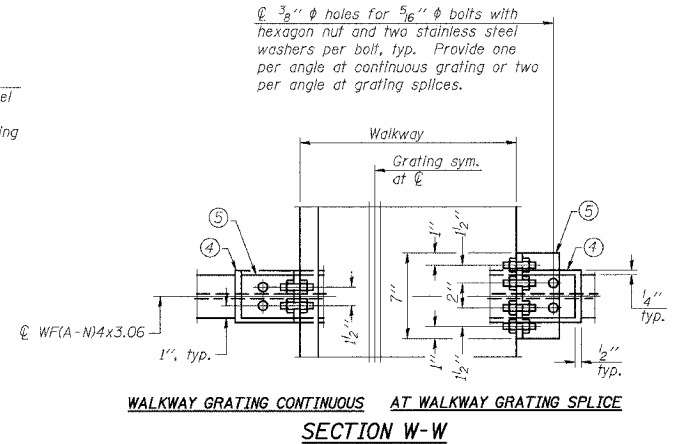
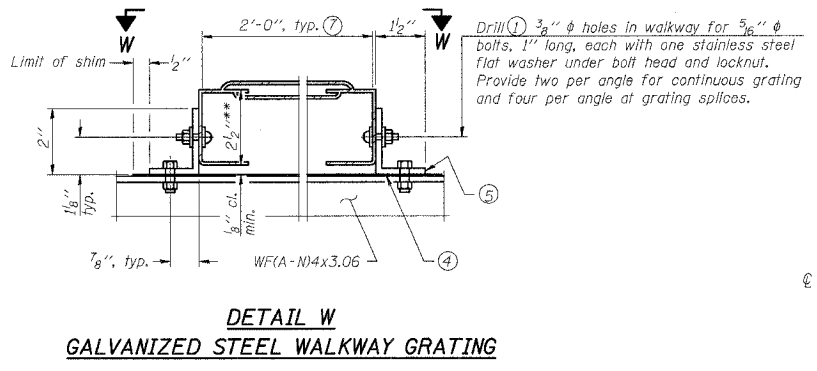
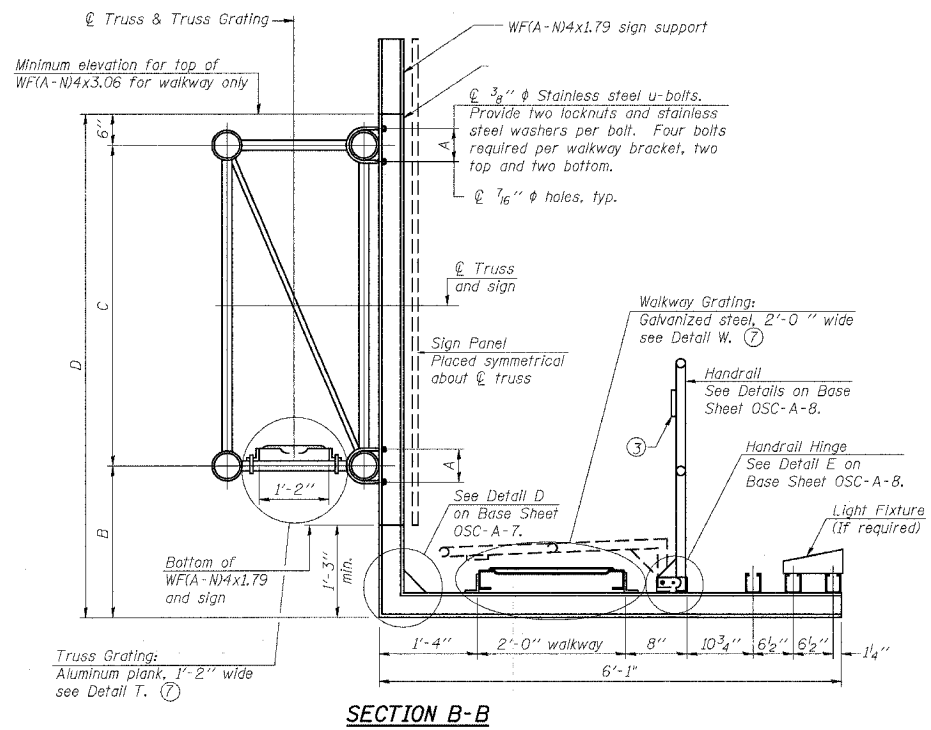

- Drilling holes in grating may be done in shop or field, based on Contractor's preference and subject to accurate alignment.
- When truss grating must be spliced, use suggested details or other methods in accord with grating manufacturer's recommendation and subject to the Engineer's review and approval.
- 1/2" x 1/2" x 2" welded to handrail posts to protect locations that contact grating.
- 1/8" (or 16 ga.) x 2 1/2" x 4" stainless steel shim adhered to top of WFCA-N4x3.06 beneath each galvanized angle, typ. Adhesives for shims shall be suitable for materials joined and full exposure conditions.
- Galvanized steel L 2" x 1 1/2" x 1/4", 3 1/2" long with continuous grating 7 1/2" long at grating splice.
- Details shown are considered equal alternatives to Aluminum Walkway Details and may be substituted by Contractor at no charge in contract cost.
- Perforated or expanded metal grating providing a skid resistant (non-serrated) surface and capable of supporting a 500 pound concentrated load with a 6'-0" clear span. Walkway and truss grating dimensions are nominal and may vary (width ± 1/2", depth ± 1/2") based on available standard sizes. Cut ends of grating shall be free of burrs or hazardous projections and coated with zinc-rich primer or equivalent.

ALUMINUM TRUSS GRATING

Structure Number	Station	A	B	C	D
9C100I057R53.1	1515+50	7'	6'	5'-6"	12'

NUMBER	REVISION	DATE

OSC-A-7S 1-7-05

REVISIONS		ILLINOIS DEPARTMENT OF TRANSPORTATION
NAME	DATE	
		CANTILEVER SIGN STRUCTURES ALTERNATE WALKWAY DETAILS SCALE: VERT. NONE HORIZ. DATE DRAWN BY CNH CHECKED BY

DATE = 12/13/2006
 FILE NAME = c:\p\sc\osc-a-7s\osc-a-7s.dgn
 PLOT SCALE = 56.8000 / 1 IN.
 USER NAME = headen

F.A. RTE.	SECTION	COUNTY	TOTAL SHEETS	SHEET NO.
*	**	WILLIAMSON	917	748
STA. TO STA.				
FED. ROAD DIST. NO. ILLINOIS FED. AID PROJECT				
* I-57, & OLD IL 13 (FAU 9629)				
** (X1-6-2)VB-2,(X1-6)HBK-2				

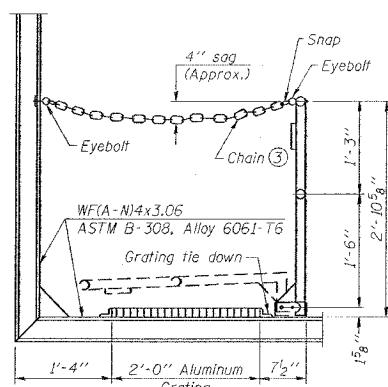

SIDE ELEVATION
(Showing Safety Chain W/O Sign)

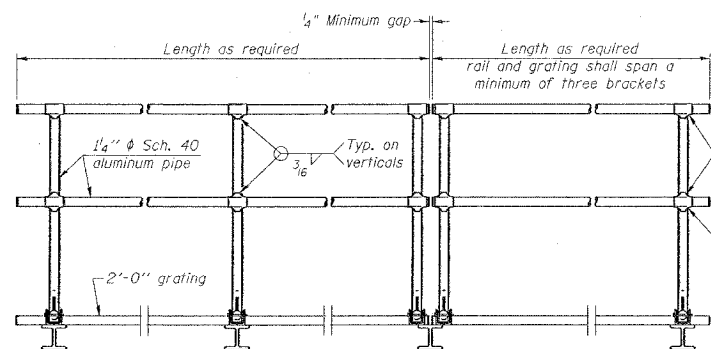

HANDRAIL DETAILS

Handrail pipe shall be ASTM B241, Alloy 6063-T6 or Alloy 6061-T6.

FRONT ELEVATION

- Install standard force-fit end caps or weld 1/2" end plates with 1/8" c.f.w. and grind smooth. (All rail ends)
- Horizontal handrail member shall be continuous thru fitting. Provide 1/16" hole in fitting for 3/8" bolt. Field drill 7/16" hole in horizontal rail member. Provide locknut and two stainless steel washers for bolt. (Use 5/16" eyebolts in 1/16" holes on top rail at ends only.)

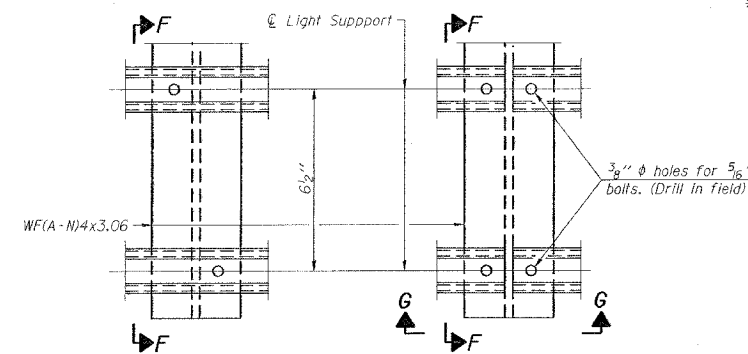

DETAIL F

DETAIL G

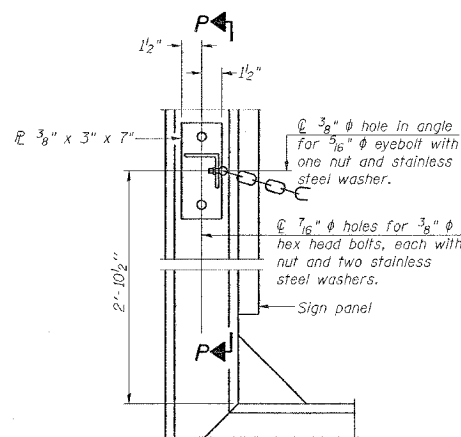

ALTERNATE SAFETY CHAIN ATTACHMENT
(With Sign Present)

Items not shown same as "Side Elevation" of "Handrail Details"

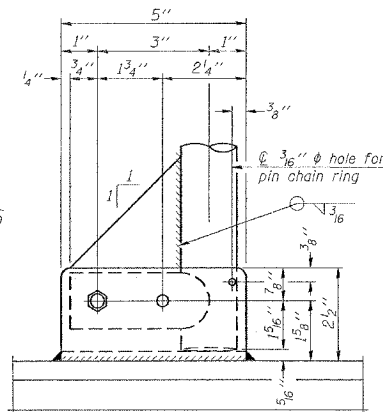

SIDE ELEVATION

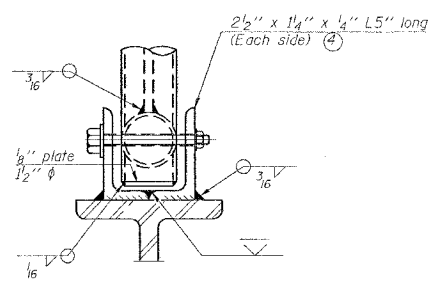

FRONT ELEVATION

Details not shown same as "ELEVATION" at right.

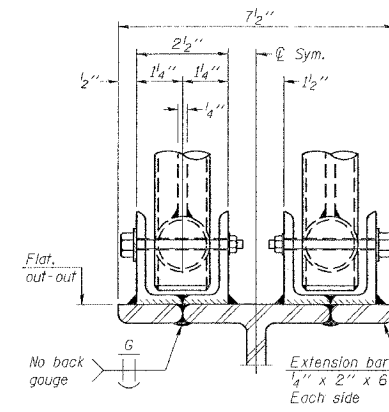

ELEVATION AT HANDRAIL JOINT ④

Details not shown same as "FRONT ELEVATION"

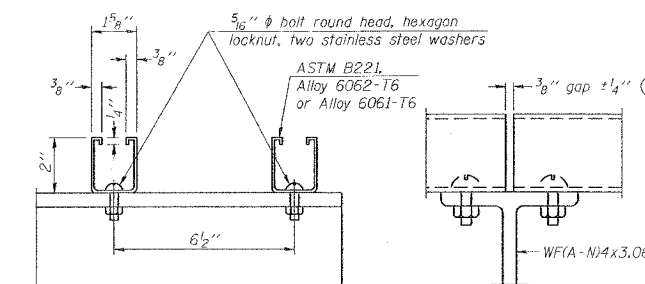

SECTION F-F

SECTION G-G

LIGHTING FIXTURE MOUNTS (IF REQUIRED)

- Field cut ends of light support channels shall be free of burrs or hazardous projections and coated with zinc-rich primer or equivalent.

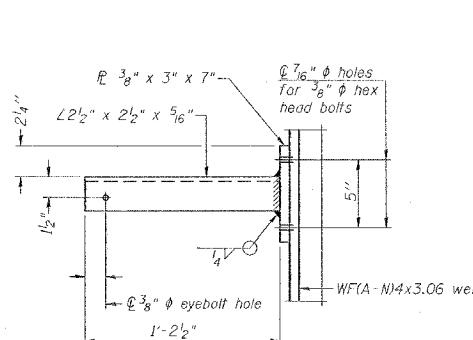

SECTION P-P

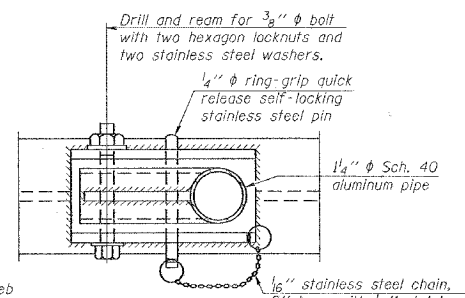

PLAN
DETAIL E HANDRAIL HINGE

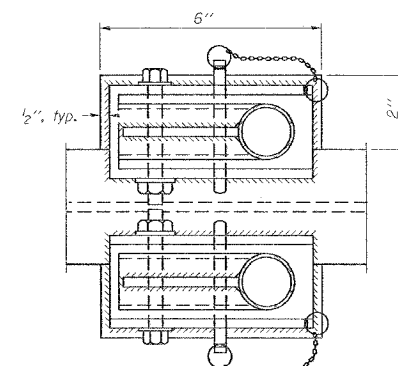

PLAN AT HANDRAIL JOINT

Details not shown same as "PLAN"

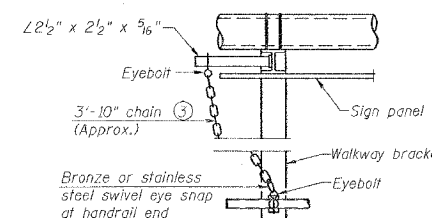

ALTERNATE SAFETY CHAIN ATTACHMENT

Details not shown similar to "Safety Chain" Details (Walkway omitted for clarity)

- 3/16" galvanized steel chain, approximately 12 links per foot. Chain to be hot dip galvanized after manufacture and suitable for prolonged exterior exposure. Alternate materials may be substituted with the Engineer's approval.
- Extrusions may be used in lieu of the details shown, with approval of the Engineer.

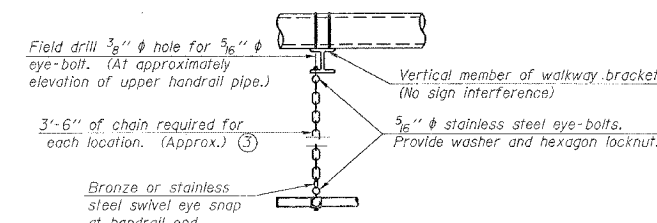

SAFETY CHAIN

One required for each end of each walkway.

NUMBER	REVISION	DATE

REVISIONS	
NAME	DATE

ILLINOIS DEPARTMENT OF TRANSPORTATION
**CANTILEVER SIGN STRUCTURES
HANDRAIL DETAILS
ALUMINUM TRUSS & STEEL POST**

SCALE: VERT. NONE
HORIZ. DATE

DRAWN BY CNH
CHECKED BY

CONTRACT NO. 98950				
F.A. RTE.	SECTION	COUNTY	TOTAL SHEETS	SHEET NO.
*	**	WILLIAMSON	917	749
STA.		TO STA.		
FED. ROAD DIST. NO.	ILLINOIS	FED. AID PROJECT		
* I-57, & OLD IL 13 (FAU 9629)				
** (X1-6-2)VB-2,(X1-6)HBK-2				

• Grind anchor rod to bright finish at ground clamp location before installing clamp.

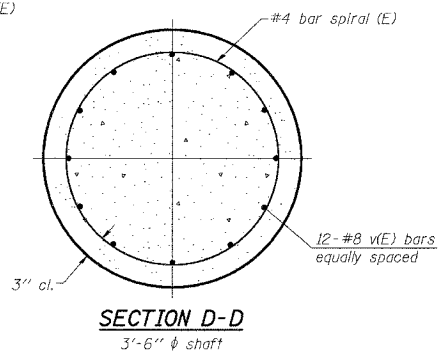
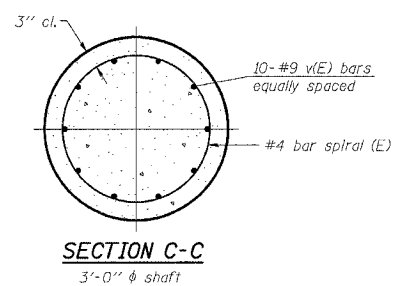
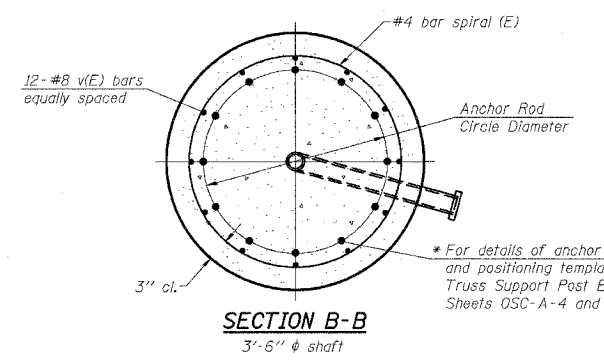
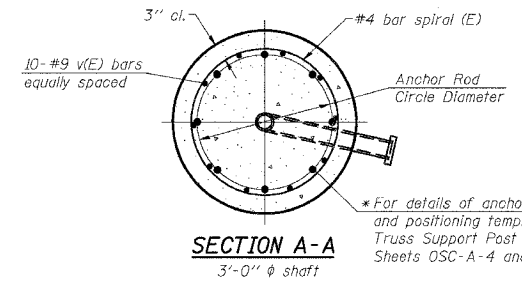
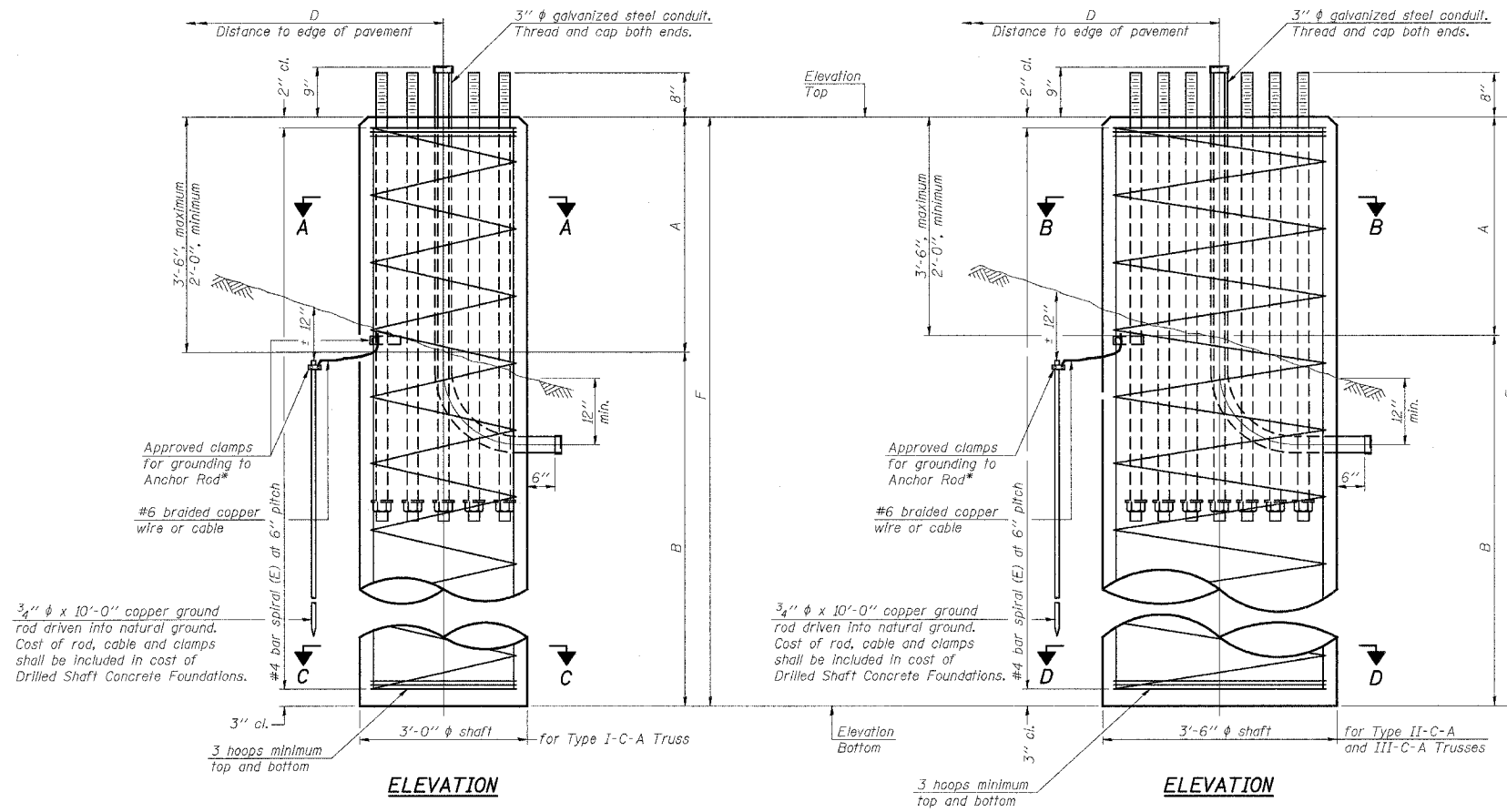

NOTES:
 The foundation dimensions shown in the Foundation Design Table are based on the presence of mostly cohesive soils with an average Unconfined Compressive Strength (Qu) of at least 1.25 tsf, which must be determined by previous soil investigations at the jobsite. When other conditions are indicated, the boring data will be included in the plans and the foundation dimensions shown in the Foundation Data Table will be the result of site specific designs.
 If the conditions encountered are different than those indicated, the Contractor shall notify the Engineer to determine if the foundation dimensions need to be modified. If dimensions "B" or "F" are revised by more than 12" by the Contractor, "as-built" plans shall be prepared and submitted to the District Bureau of Operations for future reference.
 No sonotubes or decomposable forms shall be used below the lower conduit entrance. Permanent metal forms or other shielding may not be left in place below that elevation without the Engineer's written permission.
 Concrete shall be placed monolithically, without construction joints.
 Backfill shall be placed per Article 502 of Standard Specification and prior to erection of support column.
 A normal surface finish followed by a Bridge Seat Sealer application will be required on concrete surfaces above the lowest elevation 6" below finished ground line. Cost included in "Drilled Shaft Concrete Foundation".

Structure Number	Station	Truss Type	Shaft Diameter	Elevation Top	Elevation Bottom	Qu	A	B	F	Class SI Concrete Cubic Yards
9C100I057R53.1	1515+50	II-C-A	3.5	467.3	447.8	1.32	2.5'	17'	19.5'	6.9

Truss Type	Post Base Sheet	Maximum Cantilever Length (ft)	Maximum Total Sign Area (sq ft)	Shaft Diameter (in)	"B" Depth (ft)	Anchor Rods		Anchor Rod Circle Diameter (in)
						No.	Diameter (in)	
I-C-A	OSC-A-4	25	170	3.0	16.0	8	2	22
II-C-A	OSC-A-5	30	170	3.5	17.0	12	2	30
II-C-A	OSC-A-5	30	340	3.5	21.5	12	2	30
III-C-A	OSC-A-5	35	170	3.5	19.0	12	2	30
III-C-A	OSC-A-5	35	250	3.5	22.5	12	2	30
III-C-A	OSC-A-5	35	400	3.5	26.5	12	2	30
III-C-A	OSC-A-5	40	400	3.5	32.0	12	2	30

NUMBER	REVISION	DATE

REVISIONS	
NAME	DATE

ILLINOIS DEPARTMENT OF TRANSPORTATION
**CANTILEVER SIGN STRUCTURES
 DRILLED SHAFT
 ALUMINUM TRUSS & STEEL POST**
 SCALE: VERT. NONE
 HORIZ. DATE
 DRAWN BY CNH
 CHECKED BY

PLOT DATE = 12/13/2006
 FILE NAME = c:\p\proj\98950\98950.dwg
 USER NAME = hanson

F.A. RTE.	SECTION	COUNTY	TOTAL SHEETS	SHEET NO.
*	**	WILLIAMSON	917	750
STA.		TO STA.		
FED. ROAD DIST. NO. ILLINOIS FED. AID PROJECT				
* I-57, & OLD IL 13 (FAU 9629)				
** (X1-6-2)VB-2,(X1-6)HBK-2				

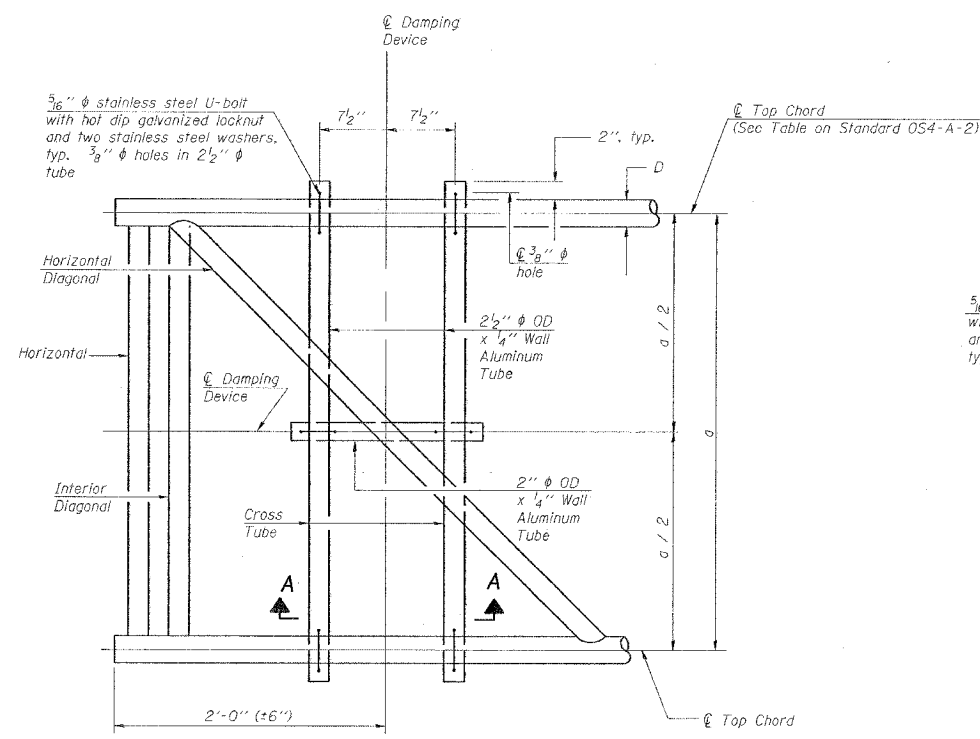

PLAN DETAIL

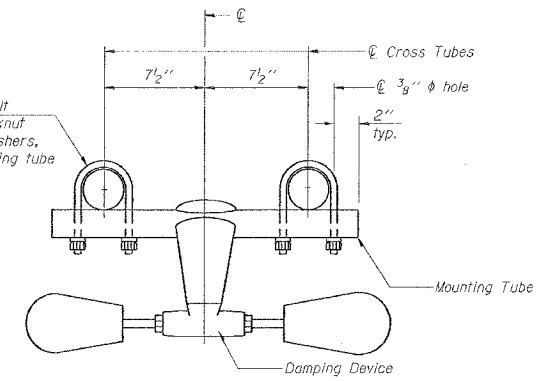

TRUSS DAMPING DEVICE CONNECTION DETAIL

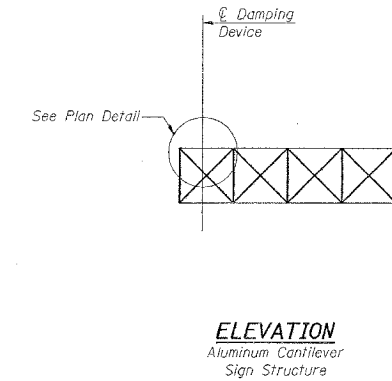

ELEVATION
Aluminum Cantilever Sign Structure

GENERAL NOTES

Damper: One damper per truss. (31 lbs. Stockbridge-Type Aluminum)
Materials: Aluminum tubes shall be ASTM B221 alloy 6061 temper T6

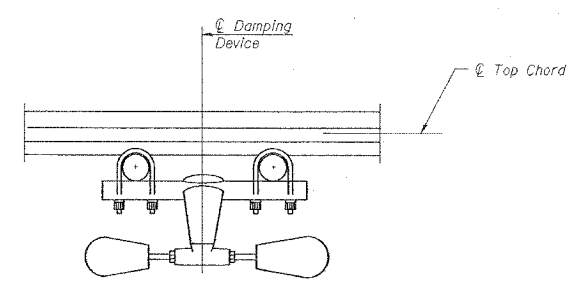

SECTION A-A

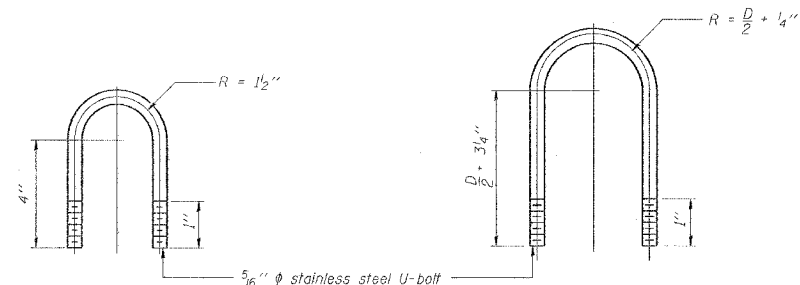

DAMPING DEVICE MOUNTING TUBE U-BOLT DETAIL
(Typical)

TOP CHORD TO CROSS TUBE U-BOLT DETAIL
(Typical)

PLOT DATE = 10/12/2006
 PLOT SCALE = 1/8" = 1'-0"
 USER NAME = hanson

OSC-A-D 1-7-05

REVISIONS	
NAME	DATE

ILLINOIS DEPARTMENT OF TRANSPORTATION

**CANTILEVER SIGN STRUCTURE
DAMPING DEVICE**

SCALE: VERT. NONE
HORIZ. DRAWN BY CNH
DATE CHECKED BY

CONTRACT NO. 98950				
F.A. RTE.	SECTION	COUNTY	TOTAL SHEETS	SHEET NO.
*	**	WILLIAMSON	917	751
STA.		TO STA.		
FED. ROAD DIST. NO.		ILLINOIS FED. AID PROJECT		
* I-57, & OLD IL 13 (FAU 9629)				
** (X1-6-2)VB-2,(X1-6)HBK-2				

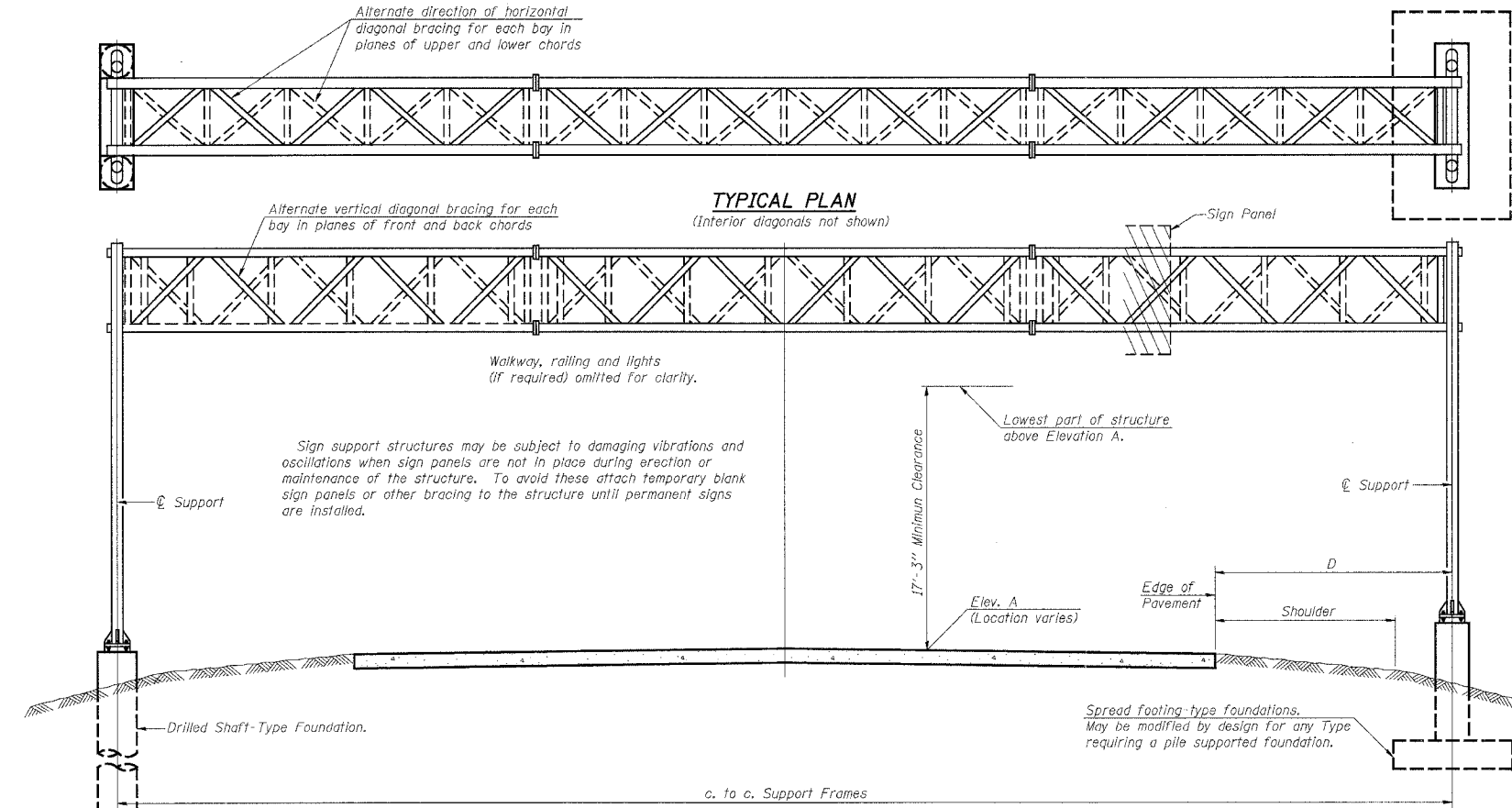

GENERAL NOTES

DESIGN: AASHTO Standard Specifications for Structural Supports for Highway Signs, Luminaires and Traffic Signals. ("AASHTO Specifications")

CONSTRUCTION: Current (at time of letting) Illinois Department of Transportation Standard Specifications for Road and Bridge Construction, Supplemental Specifications and Special Provisions. ("Standard Specifications")

LOADING: 90 M.P.H. WIND VELOCITY

WIND LOADING: 30 p.s.f. normal to Sign Panel Area and truss elements not behind sign Loading Diagram.

WALKWAY LOADING: Dead load plus 500 lbs. concentrated live load.

DESIGN STRESSES:
Field Units
f_c = 3,500 p.s.i.
f_y = 60,000 p.s.i. (reinforcement)

WELDING: All welds to be continuous unless otherwise shown. All welding to be done in accordance with current AWS D1.1 and D1.2 Structural Welding Codes (Steel and Aluminum) and the Standard Specifications.

MATERIALS: Aluminum Alloys as shown throughout plans. All Structural Steel Pipe shall be ASTM A53 Grade B with a minimum yield of 35,000 p.s.i., or A500 Grade B or C with a minimum yield of 46,000 p.s.i. If A500 pipe is substituted for A53, then the outside diameter shall be as detailed and wall thickness greater than or equal to A53.

All Structural Steel Plates and Shapes shall conform to AASHTO M270 Gr. 36, Gr. 50 or Gr. 50W*. Stainless steel for shims, sleeves and handhole covers shall be ASTM A240, Type 302 or 304, or another alloy suitable for exterior exposure and acceptable to the Engineer. The steel pipe and stiffening ribs at the base plate for the column shall have a minimum longitudinal Charpy V-Notch (CVN) energy of 15 lb.-ft. at 40° F. (Zone 2) before galvanizing.

FASTENERS FOR ALUMINUM TRUSSES: All bolts noted as "high strength" must satisfy the requirements of AASHTO M164 (ASTM A325), or approved alternate, and must have matching lock nuts. Threaded studs for splices (if Members interfere) must satisfy the requirements of ASTM A449, ASTM A193, Grade B7, or approved alternate, and must have matching lock nuts. Bolts and lock nuts not required to be high strength must satisfy the requirements of ASTM A307. All bolts and lock nuts must be hot dip galvanized per AASHTO M232. The lock nuts must have nylon or steel inserts. A stainless steel flat washer conforming to ASTM A240 Type 302 or 304, is required under both head and nut or under both nuts where threaded studs are used. High strength bolt installation shall conform to Article 505.04 (f) (2)d of the IDOT Standard Specifications for Road and Bridge Construction. Rotational capacity ("ROCAP") testing of bolts will not be required.

U-BOLTS AND EYEBOLTS: U-Bolts and Eyebolts must be produced from ASTM A276 Type 304, 304L, 316 or 316L, Condition A, cold finished stainless steel, or an equivalent material acceptable to the Engineer. All nuts for U-Bolts and Eyebolts must be lock nuts equivalent to ASTM A307 with nylon or steel inserts and hot dip galvanized per AASHTO M232. A stainless steel flat washer conforming to ASTM A240, Type 302 or 304, is required under each U-Bolt and Eyebolt lock nut.

GALVANIZING: All Steel Grating, Plates, Shapes and Pipe shall be Hot Dip Galvanized after fabrication in accordance with AASHTO M11. Painting is not permitted.

ANCHOR RODS: Shall conform to AASHTO M314 Gr. 36 or 55 with a minimum Charpy V-Notch (CVN) energy of 15 lb.-ft. at 40° F.

CONCRETE SURFACES: All concrete surfaces above an elevation 6" below the lowest final ground line at each foundation shall be cleaned and coated with Bridge Seal Sealer in accordance with the Standard Specifications.

REINFORCEMENT BARS: Reinforcement Bars designated (E) shall be epoxy coated in accordance with the Standard Specifications.

TYPICAL ELEVATION
(Looking at Face of Signs)**

Structure Number	Station	Design Truss Type	c. to c. Supports	Elev. A	Dim. D	Height of Tallest Sign	Total Sign Area
9S1001057L52.8	1532+00	I-A	80	472.34	LT 20', RT 8'	15'-0"	508.5

Elev. A = Elevation at point of minimum clearance to sign, walkway support or truss.

**Looking upstation for structures with signs both sides.

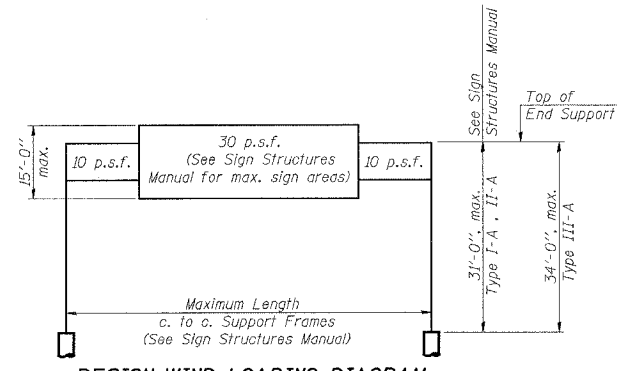

DESIGN WIND LOADING DIAGRAM

Parameters shown are basis for I.D.O.T. Standards and Sign Manual Tables. Installations not within dimensional limits shown require special analysis for all components.

TOTAL BILL OF MATERIAL

ITEM	UNIT	TOTAL
OVERHEAD SIGN STRUCTURE TYPE I-A (4'-0" x 4'-6")	Foot	80
OVERHEAD SIGN STRUCTURE WALKWAY TYPE A	Foot	57
CONCRETE FOUNDATIONS	Cu. Yds.	17.2
DRILLED SHAFT CONCRETE FOUNDATIONS	Cu. Yds.	14.8

REVISIONS		ILLINOIS DEPARTMENT OF TRANSPORTATION
NAME	DATE	
		OVERHEAD SIGN STRUCTURES GENERAL PLAN & ELEVATION ALUMINUM TRUSS & STEEL SUPPORTS

SCALE: VERT. NONE
HORIZ.
DATE
DRAWN BY CNH
CHECKED BY

NUMBER	REVISION	DATE

OS-A-1 1-7-05

PLOT DATE = 12/13/2006
FILE NAME = c:\pvc\jeps\98950\2802\01d13\01d13p5.dgn
PLOT SCALE = 50.0000 / 1 IN.
USER NAME = hewden

F.A. RTE.	SECTION	COUNTY	TOTAL SHEETS	SHEET NO.
*	**	WILLIAMSON	917	752
STA.		TO STA.		
FED. ROAD DIST. NO.		ILLINOIS FED. AID PROJECT		
		* I-57, & OLD IL 13 (FAU 9629)		
		** (X1-6-2)VB-2,(X1-6)HBK-2		

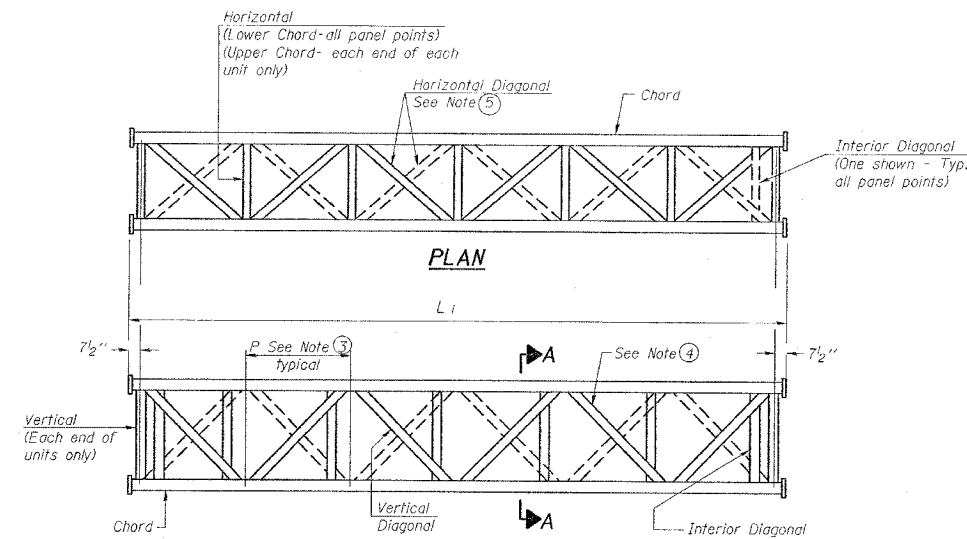

**ELEVATION
TYPICAL INTERIOR UNIT**

Even number of panels/interior unit required.

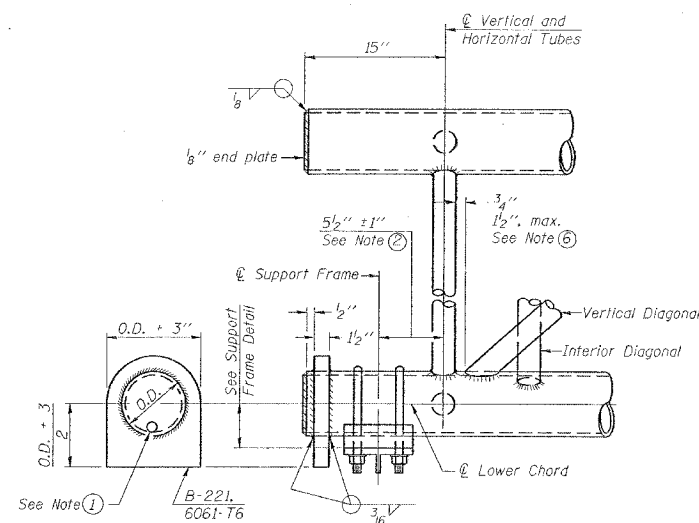

SUPPORT END DETAIL FOR EXTERIOR UNIT

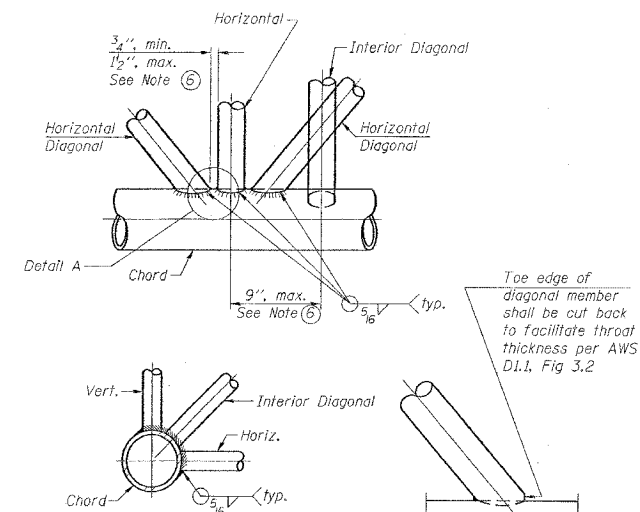

TYPICAL JOINT DETAILS

DETAIL A

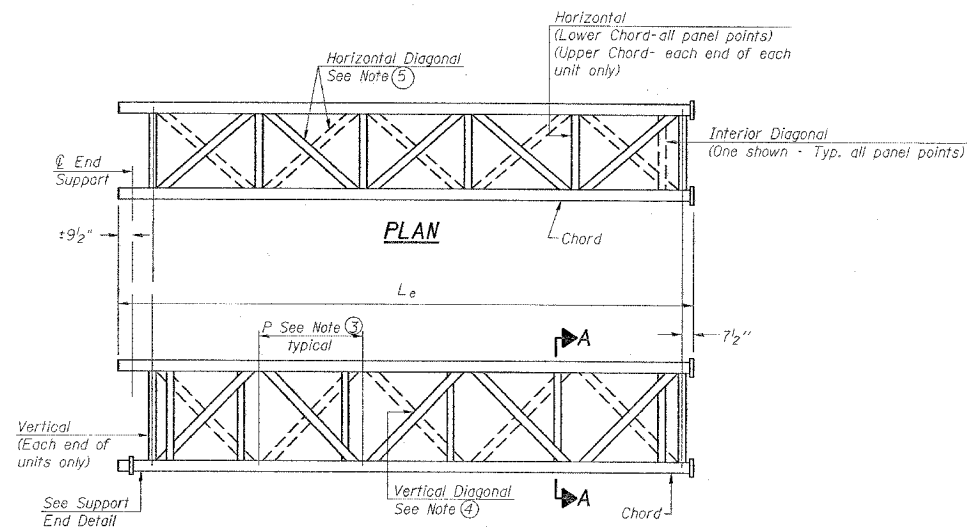

**ELEVATION
TYPICAL EXTERIOR UNIT**

Even or odd number of panels/exterior units allowed.

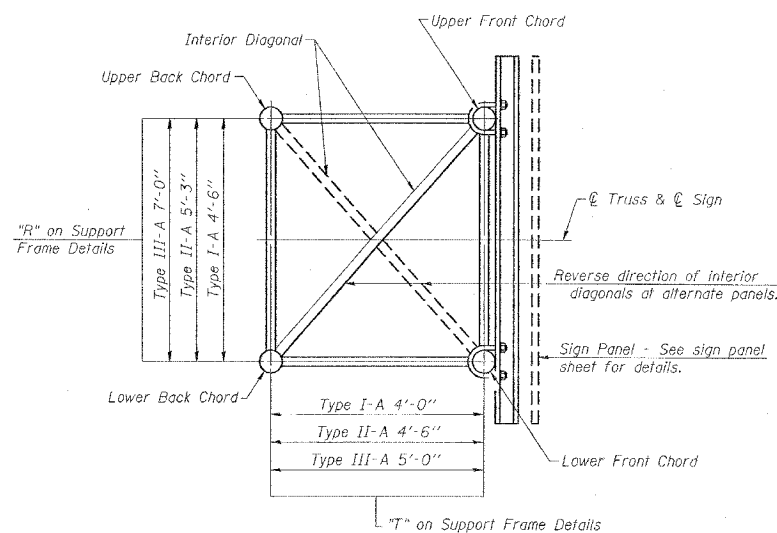

SECTION A-A

NOTES

- ① Contractor may alternatively use standard aluminum drive-fit cap to close end. 1/2" diameter drain hole in end plate/drive-fit cap. (Typ. at ends of all chords)
- ② 5 1/2" end dimension may vary by +/- 1" to provide uniform panel spacing (P).
- ③ Panel spacing (P) shall be uniform for entire truss and between 4'-0" and 5'-0" for Type I-A or 4'-0" and 5'-6" for Types II-A and III-A.
- ④ Vertical Diagonals in front and back face shall alternate.
- ⑤ Hidden lines show wind bracing alternates direction between planes of top and bottom chords.
- ⑥ All diagonals shall be detailed for minimum offset from the panel point based on the following: Offset shall be such as to provide a 3/4" minimum to 1 1/2" maximum clearance between any diagonal and any horizontal or vertical member, and to provide clearance for U-bolt connections of signs or walkway brackets.

NUMBER	REVISION	DATE

REVISIONS		ILLINOIS DEPARTMENT OF TRANSPORTATION
NAME	DATE	
		OVERHEAD SIGN STRUCTURES ALUMINUM TRUSS DETAILS FOR TRUSS TYPES I-A, II-A and III-A

SCALE: VERT. NONE
HORIZ. DATE DRAWN BY CNH
CHECKED BY

F.A. RTE.	SECTION	COUNTY	TOTAL SHEETS	SHEET NO.
*	**	WILLIAMSON	917	753
STA.		TO STA.		
FED. ROAD DIST. NO.		ILLINOIS FED. AID PROJECT		
		* I-57, & OLD IL 13 (FAU 9629)		
		** (X1-6-2)VB-2,(X1-6)HBK-2		

For anchor rod size and placement, see Support Frame Detail Sheet.

** Anchor rod shall be ground or filed to bright metal at clamp and cable connection location.

*** A normal surface finish followed by a Bridge Seat Sealer application will be required on concrete surfaces above the lowest elevation 6" below finished ground line. Cost included in Concrete Foundations.

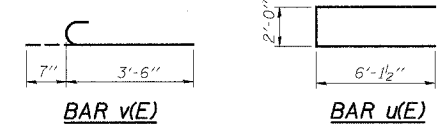
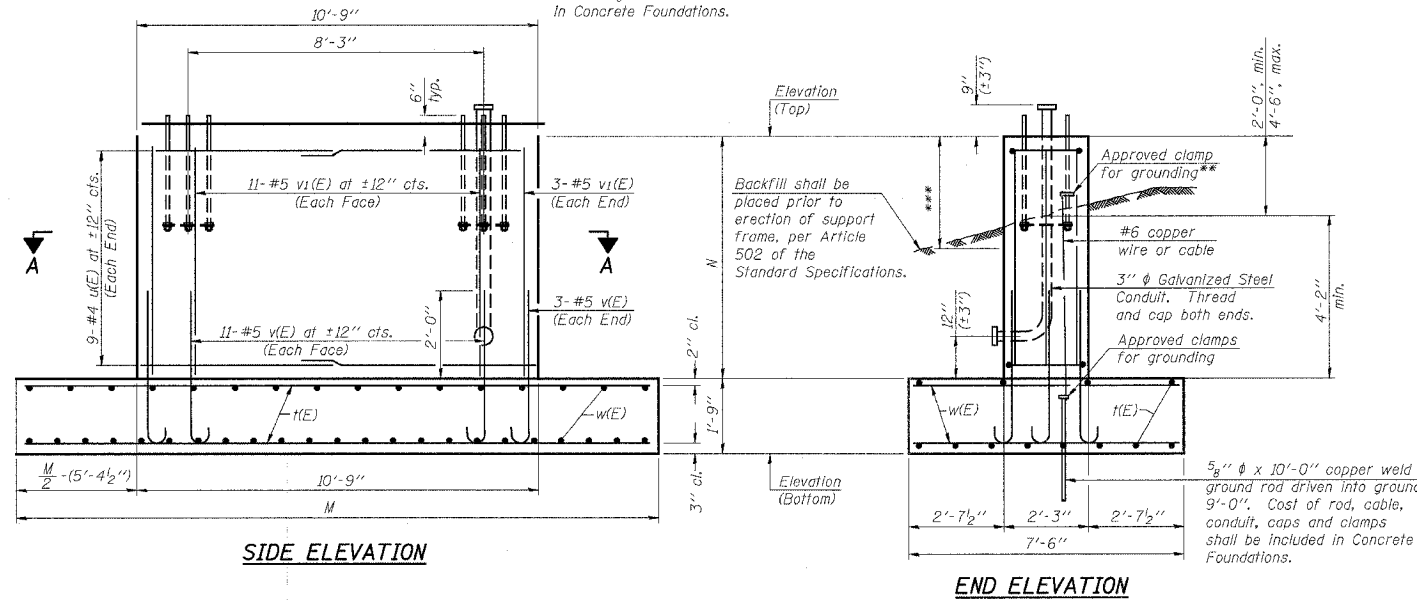

BAR LIST - EACH FOUNDATION

Bar	Number	Size	Length	Shape
u(E)	12	#5	*	U
v(E)	18	#4	14'-3"	C
v(E)	28	#5	4'-1"	U
v ₁ (E)	28	#5	*	U
w(E)	39	#5	7'-3"	U

*Length of u(E) bar = (Dim. M) - 6"
v₁(E) bar = (Dim. N) - 3"

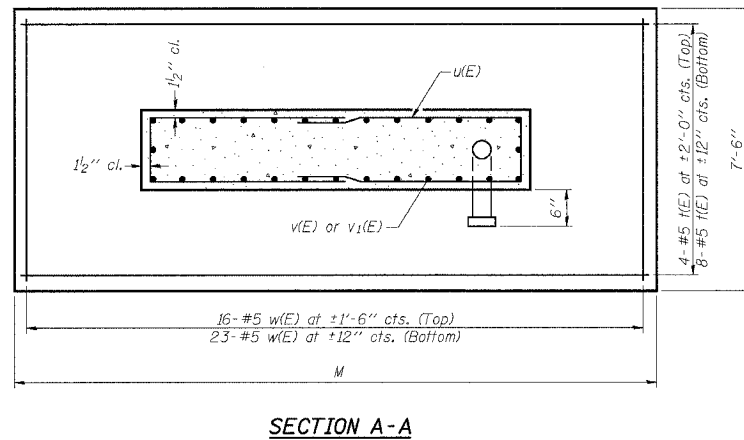

Structure Number	Station	Left Foundation				Right Foundation				Class SI Concrete (Cu. Yds.)
		Elevation Top	Elevation Bottom	N	M	Elevation Top	Elevation Bottom	N	M	
9S1001057L52.8	1532+00	471.48	462.23	7.5'	21.5'	-	-	-	-	17.2

Note:
The foundation dimensions shown are based on the presence of mostly cohesive soils with an average Unconfined Compressive Strength (Qu) of at least 1.0 tsf, which must be determined by previous soil investigations at the jobsite. When other conditions are indicated, the boring data will be included in the plans and the foundation dimensions shown will be the result of site specific designs.
During construction, if footing length or width or wall height change by more than 12", or if reinforcement is changed, "as-built" plans shall be prepared and submitted to the District Bureau of Operations for future reference.

DETAILS FOR 10" Ø SUPPORT FRAME

NUMBER	REVISION	DATE

REVISIONS		ILLINOIS DEPARTMENT OF TRANSPORTATION
NAME	DATE	
		<p align="center">OVERHEAD SIGN STRUCTURES SPREAD FOOTING DETAILS</p> <p>SCALE: VERT. NONE HORIZ.</p> <p>DATE _____ DRAWN BY CNH CHECKED BY _____</p>

PLOT DATE = 12/13/2006
FILE NAME = c:\pro\peta\4902802\old\3\old\3p5.dgn
PLOT SCALE = 50.0000' / 1" IN.
USER NAME = hraden

CONTRACT NO. 98950				
F.A. RTE.	SECTION	COUNTY	TOTAL SHEETS	SHEET NO.
*	**	WILLIAMSON	917	754
STA.		TO STA.		
FED. ROAD DIST. NO.		ILLINOIS FED. AID PROJECT		
		* I-57, & OLD IL 13 (FAU 9629)		
		** (X1-6-2)VB-2,(X1-6)HBK-2		

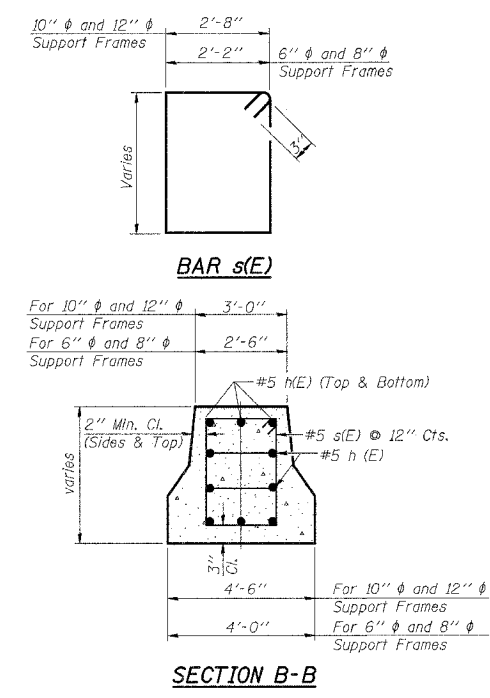
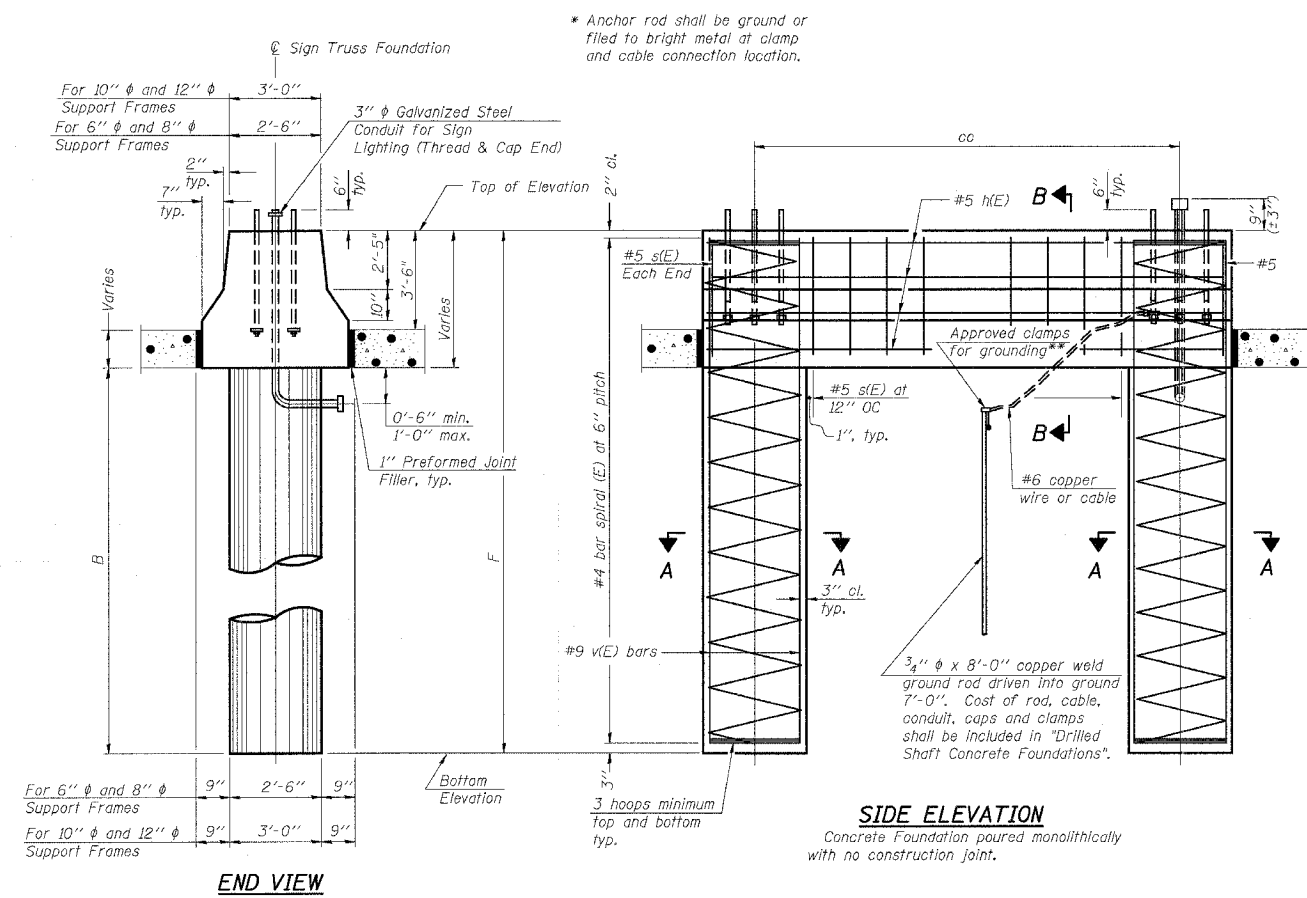

NOTES:
The Foundation dimensions shown are based on the presence of mostly cohesive soils with an average Unconfined Compressive Strength (Qu) of at least 1.25 tsf, which must be determined by previous soil investigations at the jobsite. When other conditions are indicated, the boring data will be included in the plans and the foundation dimensions shown will be the result of site specific designs.
If the conditions encountered are different than those indicated, the Contractor shall notify the Engineer to determine if the foundation dimensions need to be modified. If dimensions "B" or "F" are revised by more than 12" by the Contractor, "as-built" plans shall be prepared and submitted to the District Bureau of Operations for future reference.
No sonotubes or decomposable forms shall be used below the lower conduit entrance. Permanent metal forms or other shielding may not be left in place below that elevation without the Engineer's written permission.
Concrete shall be placed monolithically, without construction joints.
Backfill shall be placed per Article 502 of Standard Specification and prior to erection of support column.
A normal surface finish followed by a Bridge Seal Sealer application will be required on concrete surfaces above the lowest elevation 6" below finished ground line. Cost included in Drilled Shaft Concrete Foundation.

BAR LIST - EACH FOUNDATION

Bar	Number	Size	Length	Shape
h(E)	10	#5	M less 4"	
s(E)	Varies	#5	Varies	□
v(E)	16	#9	F less 0'-5"	
v(E)	24	#9	F less 0'-5"	
#4(E) bar spiral - see Side Elevation				

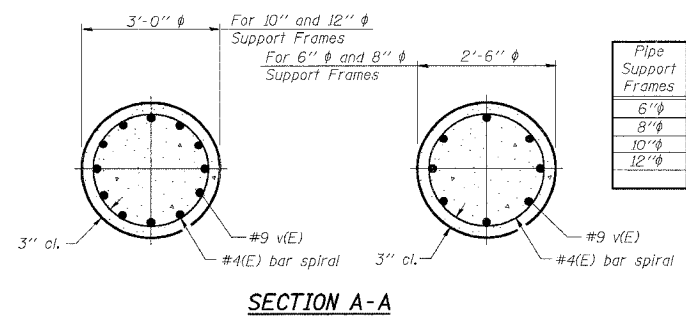
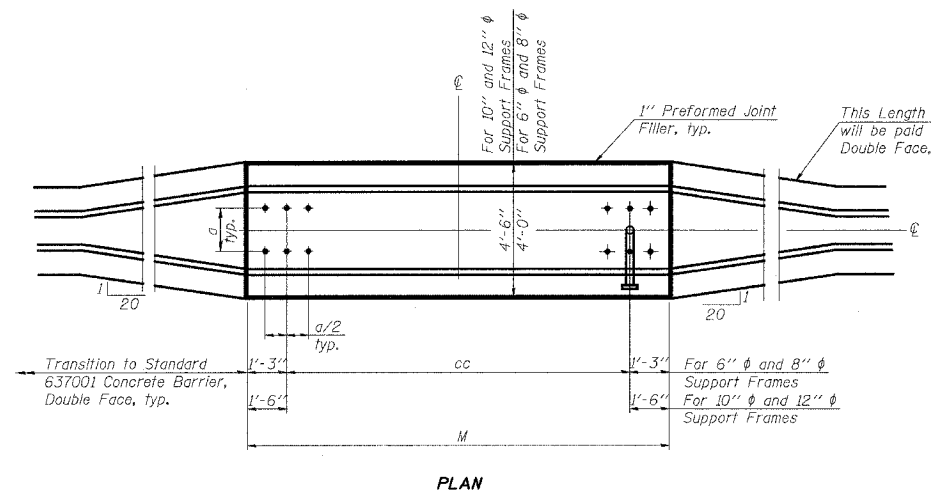

Pipe Support Frames	cc	M	a	a/2
6"φ	7'-0"	9'-6"	0'-11"	5 1/2"
8"φ	7'-6"	10'-0"	1'-1 1/2"	6 3/4"
10"φ	8'-3"	10'-9"	1'-3"	7 1/2"
12"φ	9'-0"	12'-0"	1'-6"	9"

Structure Number	Station	Left Foundation				Right Foundation				Class SI Concrete (Cu. Yds.)
		Elevation Top	Elevation Bottom	B	F	Elevation Top	Elevation Bottom	B	F	
9S1001057L52.8	1532+00	-	-	-	-	475.15	454.36	16.5	20.79	14.8

REVISIONS	
NAME	DATE

ILLINOIS DEPARTMENT OF TRANSPORTATION

**OVERHEAD SIGN STRUCTURES
MEDIAN SUPPORT FOUNDATION DETAILS**

SCALE: VERT. NONE
HORIZ.

DATE

DRAWN BY CNH
CHECKED BY

PLOT DATE = 12/13/2006
FILE NAME = c:\projects\98282\11\13\os4\os4p5.dgn
USER NAME = hanson

OS4-MED 1-7-05

F.A. RTE.	SECTION	COUNTY	TOTAL SHEETS	SHEET NO.
*	**	WILLIAMSON	917	755
STA.		TO STA.		
FED. ROAD DIST. NO.		ILLINOIS FED. AID PROJECT		
* I-57, & OLD IL 13 (FAU 9629)				
** (X1-6-2)VB-2,(X1-6)HBK-2				

TRUSS UNIT TABLE

Structure Number	Station	Design Truss Type	Exterior Units (2)			Interior Unit			Upper & Lower Chord		Verticals; Horizontals; Vertical, Horizontal, and Interior Diagonals		Camber at Midspan	Splicing Flange						
			No. Panels per Unit	Unit Lgth.(L _e)	Panel Lgth.(P)	No. Req'd.	No. Panels per Unit	Unit Lgth.(L ₁)	Panel Lgth.(P)	O.D.	Wall	O.D.		Wall	Bolts		Weld Sizes		A	B
															No./Splice	Dia.	W	W ₁		
9S1001057L52.8	1532+00	I-A	5	25'-10"	4'-9 1/2"	1	6	30'-0"	4'-9 1/2"	5	5/16	2 1/2	5/16	2.25	6	7/8	5/16	1/4	8 3/4	11 3/4

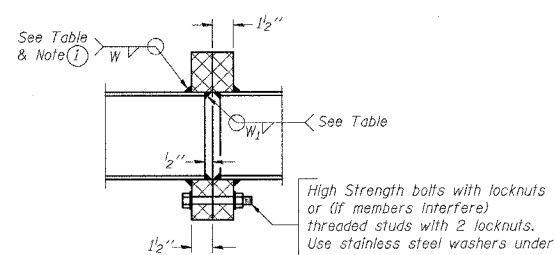

SECTION B-B

① Splicing Flanges shall be attached to each truss unit with the truss shop assembled to camber shown. Truss units shall be in proper alignment and flange surfaces shall be shop bolted into full contact before welding. Sufficient external welds or tacks shall be made to secure flanges until remaining welds are made after disassembly. Adjacent flanges shall be "match marked" to insure proper field assembly.

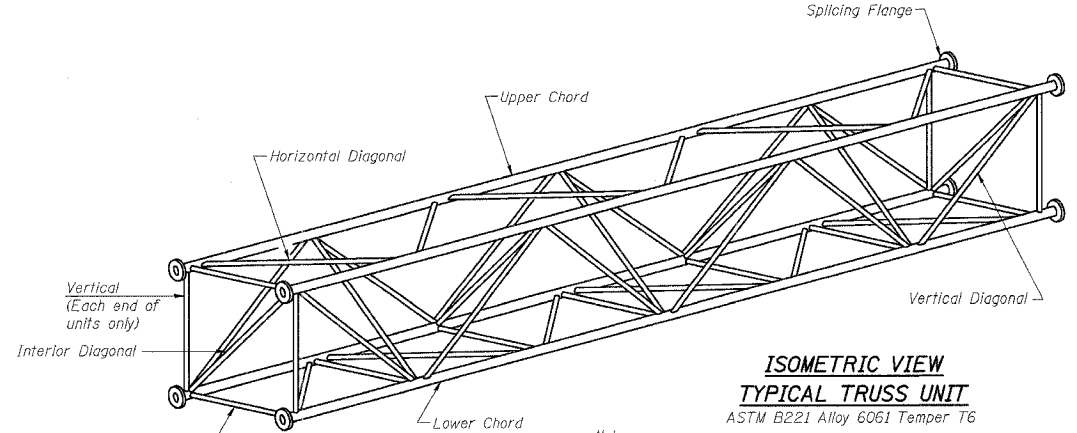

ISOMETRIC VIEW TYPICAL TRUSS UNIT
ASTM B221 Alloy 6061 Temper T6

Note: Units shall be shipped individually with adequate provision to prevent detrimental motion during transport. This may require ropes between horizontals and diagonals or energy dissipating (elastic) ties to the vehicle. The Contractor is responsible for maintaining the configuration and protection of the units.

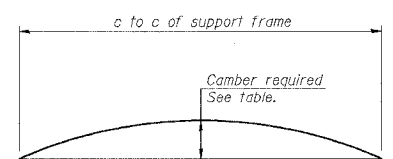

CAMBER DIAGRAM
Camber curve shown is theoretical. Actual camber attained by slope changes at splices between units.

CAMBER ATTAINMENT EXAMPLES:

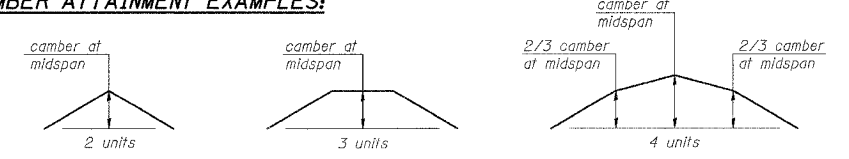

Camber shown is for fabrication only, measured with truss fully supported. (No-load condition)

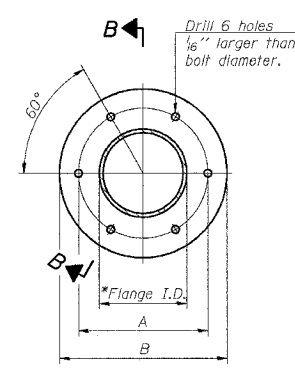

TRUSS TYPES I-A, II-A, & III-A

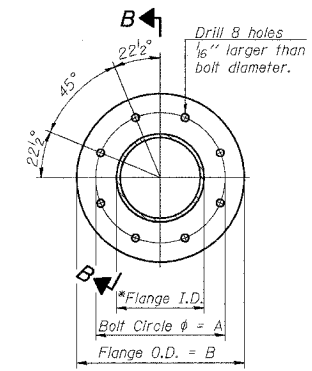

TRUSS TYPES II-A & III-A SPLICING FLANGES

ASTM B221, Alloy 6061-T6 or ASTM B209, Alloy 6061-T651
*To fit O.D. of Chord with maximum gap of 1/16".

NUMBER	REVISION	DATE

REVISIONS	
NAME	DATE

ILLINOIS DEPARTMENT OF TRANSPORTATION
OVERHEAD SIGN STRUCTURES ALUMINUM TRUSS DETAILS FOR TRUSS TYPES I-A, II-A and III-A

SCALE: VERT. NONE
HORIZ. NONE

DATE: _____ DRAWN BY CNH
CHECKED BY _____

PLOT DATE = 12/13/2006
FILE NAME = c:\p\projects\982802\c.d\3\c.d\3\p5.dgn
PLOT SCALE = 5/8"=1'-0"
USER NAME = henden

F.A. RTE.	SECTION	COUNTY	TOTAL SHEETS	SHEET NO.
*	**	WILLIAMSON	917	756
STA. TO STA.				
FED. ROAD DIST. NO.	ILLINOIS	FED. AID PROJECT		
* I-57, & OLD IL 13 (FAU 9629)				
** (X1-6-2)WB-2,(X1-6)HKB-2				

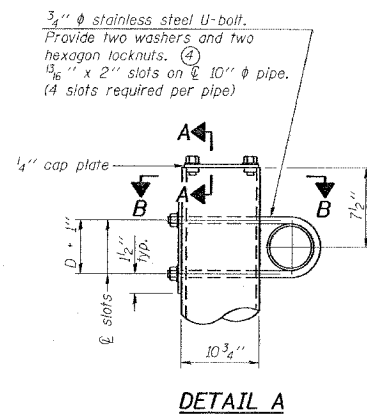

DETAIL A

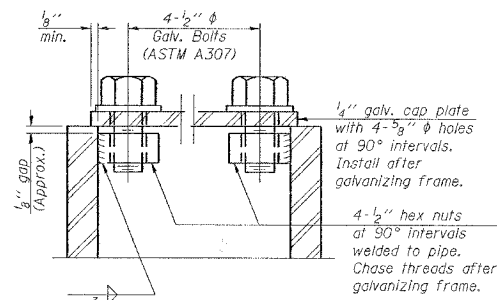

SECTION A-A

As an alternate to bolts, may use galvanized drive-fit caps installed after galvanizing frame.

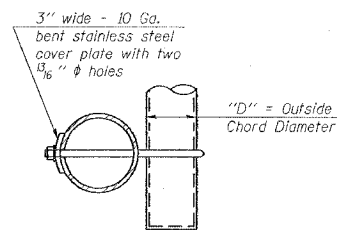

SECTION B-B

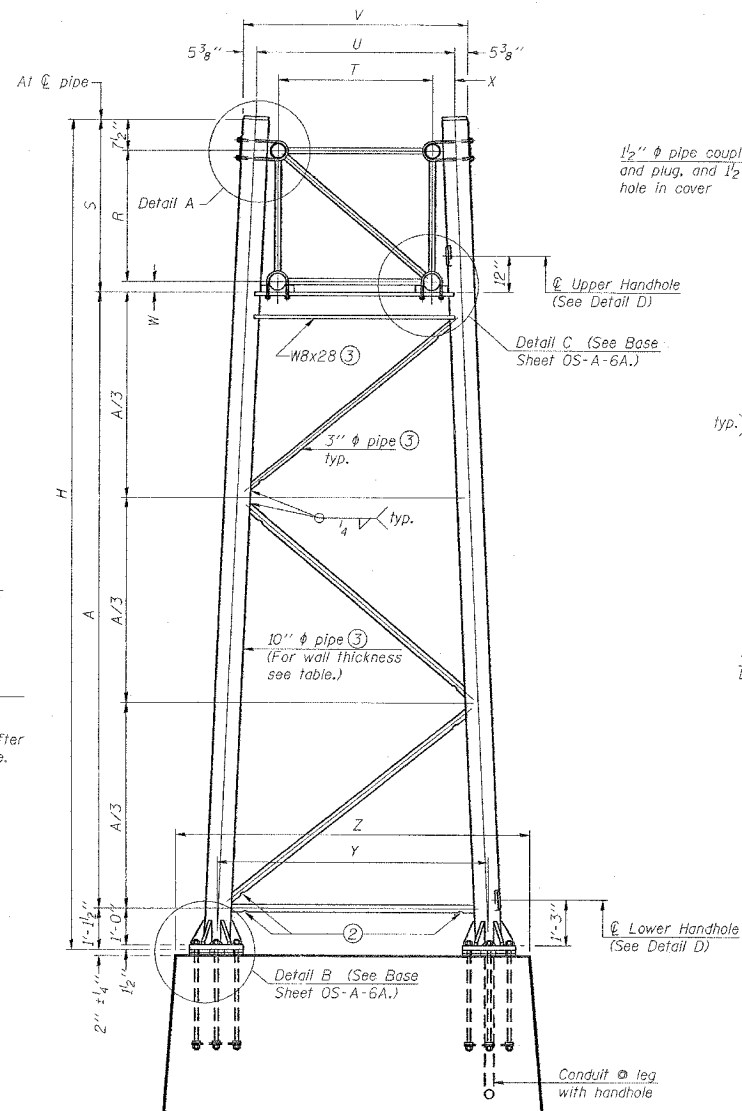

For Foundation Details, see base sheet OS-F3 (Spread Footing) or OS4-F3 (Drilled Shaft).

SIDE ELEVATION

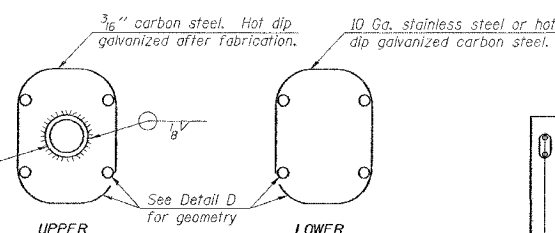

HANDHOLE COVERS

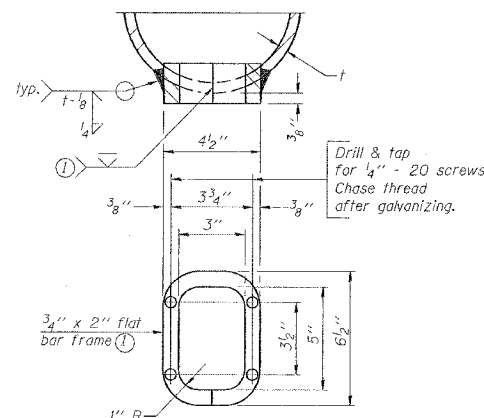

DETAIL D

Provide 6 1/2" x 4 1/2" cover. Provide 4-3/8" ϕ holes in cover for 1/4"-20 round head hot dip galvanized or stainless steel machine screws. (See cover details)

Backfill shall be placed prior to erection of support frame

END ELEVATION

Support Design Loads: See Base Sheet OS-A-1 for design and loading criteria.
Load combinations checked include deadload plus:
a) 100% wind normal to sign, 20% parallel to sign
b) 60% wind normal to sign, 30% parallel to sign

- In lieu of fabricated handhole frame as shown, may cut from 2" plate (rolling direction vertical). All cut faces to be ground to ANSI Roughness of 500 μ in or less.
- Galvanizing vent holes of adequate size shall be provided on underside of each end of bracing pipes. Alternately, holes may be provided in wall of pipe column. All vent holes shall be drilled and de-burred, typ.
- Steel pipe, plate, carbon steel handhole covers and rolled sections shall be hot dip galvanized after fabrication. Painting is not permitted. See Base Sheet OS-A-1.
- See General Notes for fasteners.
- Dimensions shown are based on selection criteria in the Sign Structures Manual. Nonstandard applications must have dimensions verified or amended as appropriate.

Structure Number	Station	Support		Truss Type	Pipe Wall Thickness	H	A
		Left	Right				
9S1001057L52.8	1532+00		X	I-A	.279	25.9	19.15
9S1001057L52.8	1532+00	X		I-A	.279	29.6	22.85

10" ϕ PIPE TRUSS SUPPORT FRAME

Truss Type	Dimensions								
	R	S	T	U	V	W	X	Y	Z
I-A	4'-6"	5'-5 1/2"	4'-0"	5'-6"	6'-4 3/4"	4"	9"	8'-3"	10'-9"
II-A (5)	5'-3"	6'-3 1/4"	4'-6"	6'-1"	6'-11 3/4"	4 3/4"	9 1/2"	8'-3"	10'-9"

NUMBER	REVISION	DATE

OS-A-6 1-7-05

REVISIONS	
NAME	DATE

ILLINOIS DEPARTMENT OF TRANSPORTATION
**OVERHEAD SIGN STRUCTURES
SUPPORT FRAME for ALUMINUM TRUSS**

SCALE: VERT. NONE
HORIZ. NONE
DATE: _____ DRAWN BY CNH
CHECKED BY _____

F.A. RTE.	SECTION	COUNTY	TOTAL SHEETS	SHEET NO.
*	**	WILLIAMSON	917	757
STA. TO STA.				
FED. ROAD DIST. NO. ILLINOIS FED. AID PROJECT				
* I-57, & OLD IL 13 (FAU 9629)				
** (X1-6-2)VB-2,(X1-6)HBK-2				

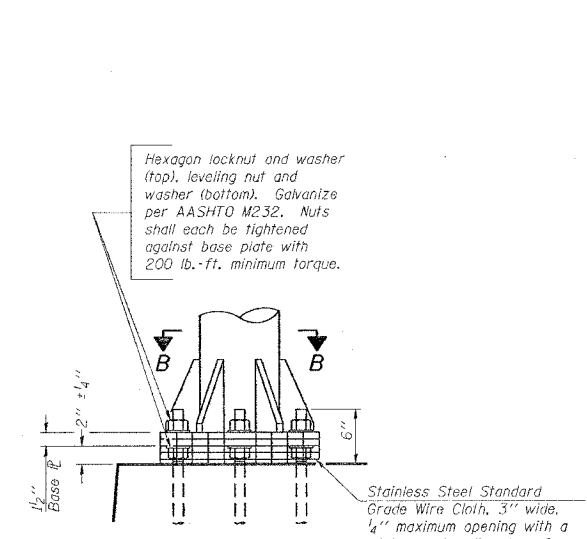

DETAIL B
Ribs shall be cut to fit slope of pipe.
Stainless Steel Standard Grade Wire Cloth, 3" wide, 4" maximum opening with a minimum wire diameter of AWG. No. 16 with a minimum 2" lap. Secure to base plate after erection with 3/4" stainless steel banding.

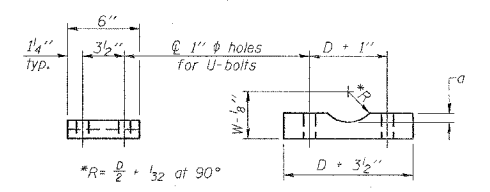
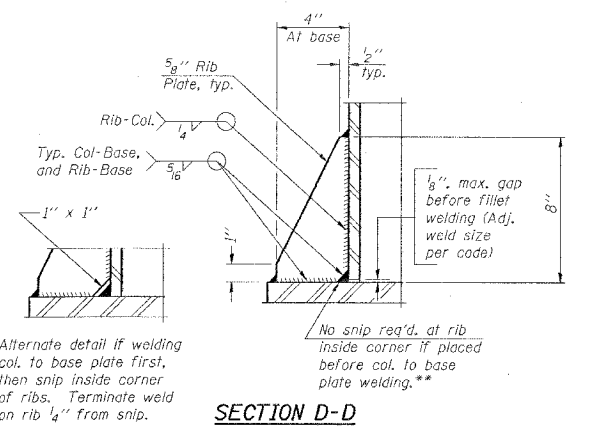
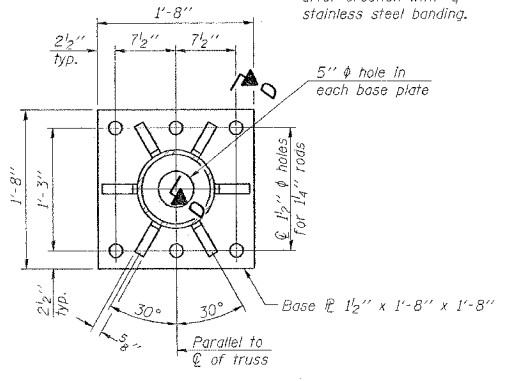

*R = D/2 + 3/2 at 90°
D = Outside Diameter of Chord.
For W. see Base Sheet OS-A-6.

SADDLE SHIM DETAIL
ASTM B26 Alloy 356-F
or
ASTM B209 Alloy 6061-T651
(4 required per sign truss)

Truss Chord Nominal Dia.	a
5"	3 1/4"
5 1/2"	4"
6"	4 1/2"
6 1/2"	5 1/4"
7"	6"

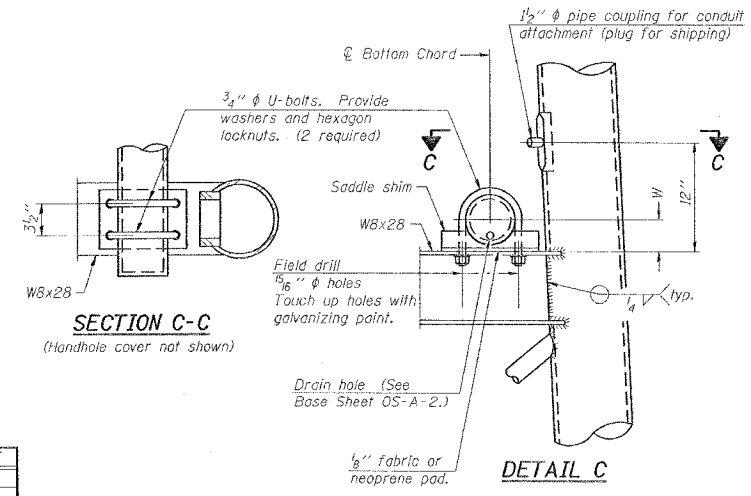
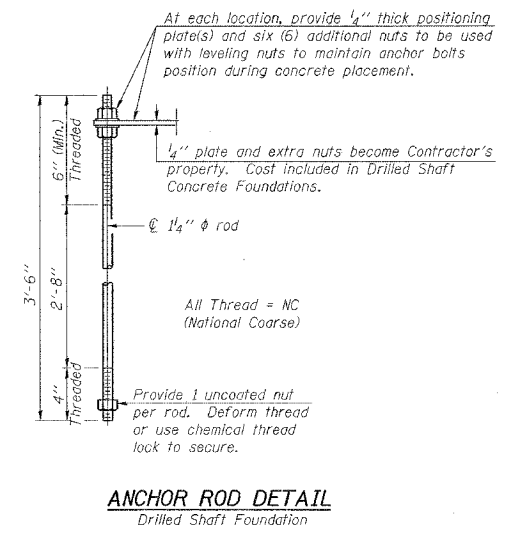
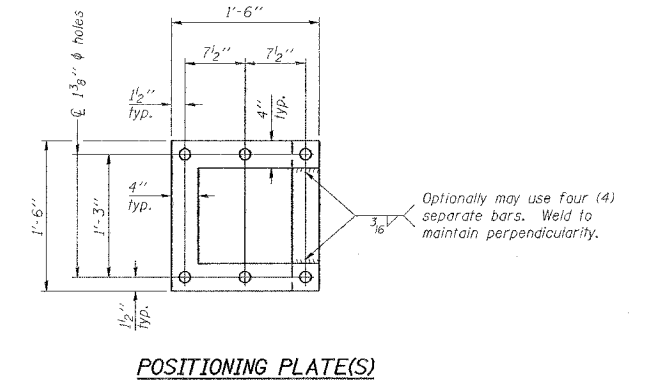
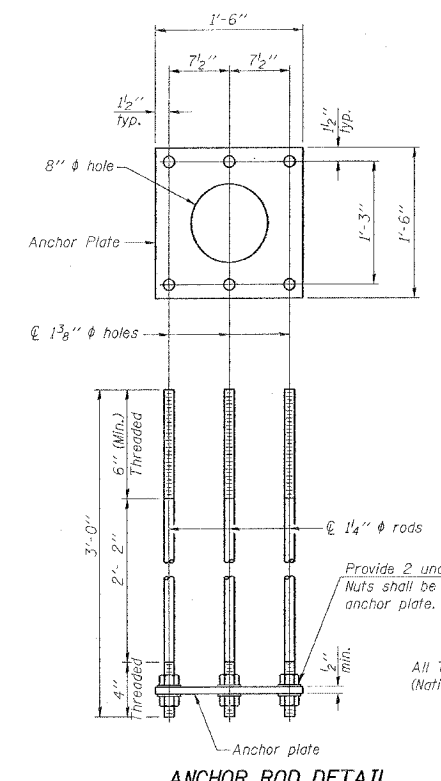

Anchor rods shall conform to AASHTO M314 Grade 36 of 50 and meet Charpy V-Notch (CVN) energy of 15 lb.-ft. at 40° F. Galvanize upper 12" per AASHTO M232. No welding shall be permitted on rods.

10" PIPE SUPPORT FRAME DETAILS

NUMBER	REVISION	DATE

REVISIONS		ILLINOIS DEPARTMENT OF TRANSPORTATION
NAME	DATE	
		<p>OVERHEAD SIGN STRUCTURES SUPPORT FRAME DETAILS ALUMINUM TRUSS</p> <p>SCALE: VERT. NONE HORIZ. DATE</p> <p>DRAWN BY CNH CHECKED BY</p>

PLOT DATE = 10/12/2005
 PLOT SCALE = 5/8" = 1'-0"
 PLOT SIZE = 24" x 36"
 USER NAME = hansen

F.A. RTE.	SECTION	COUNTY	TOTAL SHEETS	SHEET NO.
*	**	WILLIAMSON	917	758
STA. TO STA.				
FED. ROAD DIST. NO.			ILLINOIS FED. AID PROJECT	
			* I-57, & OLD IL 13 (FAU 9629)	
			** (X1-6-2)VB-2,(X1-6)HBK-2	

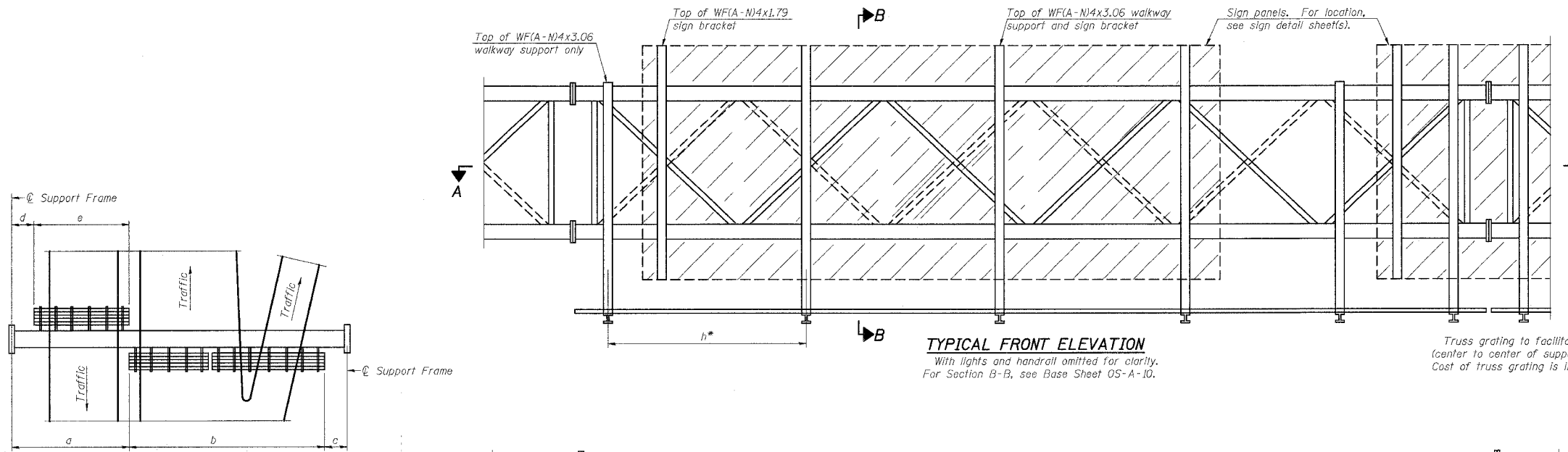

TYPICAL FRONT ELEVATION
With lights and handrail omitted for clarity.
For Section B-B, see Base Sheet OS-A-10.

Truss grating to facilitate inspection shall run full length (center to center of support frames) ±12" on overhead trusses.
Cost of truss grating is included in "Overhead Sign Structure".

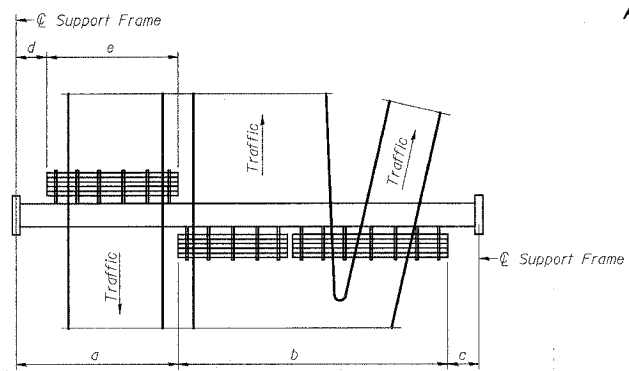

PLAN WALKWAY AND HANDRAIL SKETCH
(Road plan beneath Truss varies)

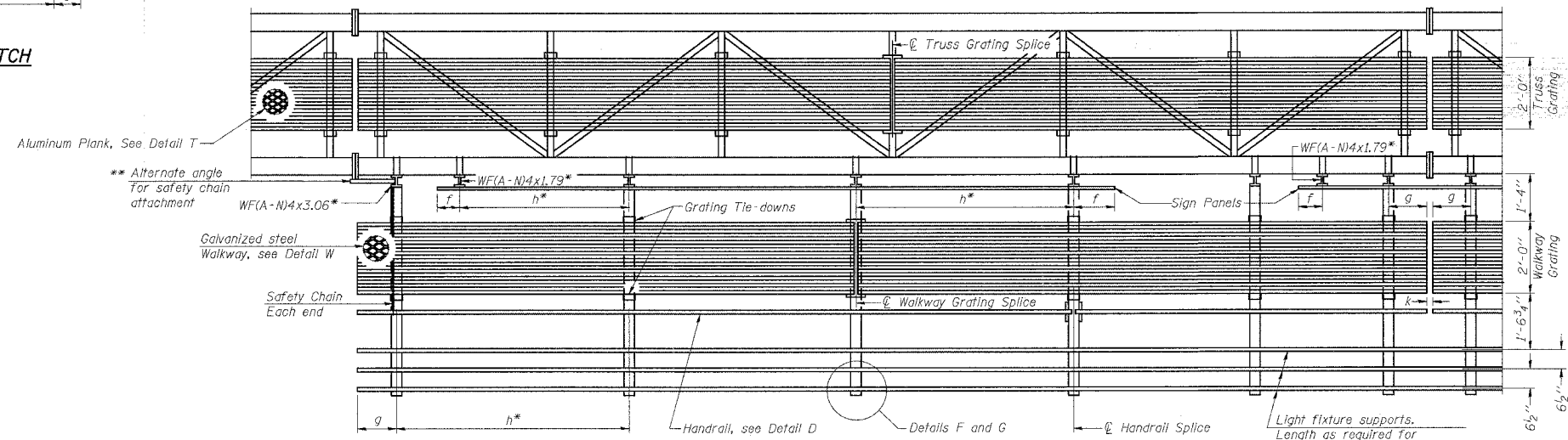

SECTION A-A

Handrail and walkway shall span a minimum of three brackets between splices and/or gap joints. Place all sign and walkway brackets as close to panel points as practical. Grating, handrail and light support splices placed as needed.

Notes:
Details shown are considered equal alternatives to the Aluminum Walkway on Base Sheet OS-A-9, and may be substituted by Contractor at no change in contract cost.

Walkway and Truss Grating width dimensions are nominal and may vary ±1/2" based on available standard widths.

BRACKET TABLE

Sign Width		Number Brackets Required
Greater Than	Less Than or Equal To	
8'-0"	14'-0"	2
14'-0"	20'-0"	4
20'-0"	26'-0"	5
26'-0"	32'-0"	6

- Notes:
- Space walkway brackets WF(A)-N4x3.06 and sign brackets WF(A)-N4x1.79 for efficiency and within limits shown:
 - f = 12" maximum, 4" minimum (End of sign to center of nearest bracket)
 - g = 12" maximum, 4" minimum (End of walkway grating to center of nearest support bracket)
 - h = 6'-0" maximum (center to center of sign and/or walkway support brackets, WF(A)-N4x1.79 or WF(A)-N4x3.06)
 - k = 2" maximum gap between adjacent walkway grating sections and handrail ends
 - ** If walkway bracket at safety chain location is behind sign, add angle to bracket, see Alternate Safety Chain Attachment on Base Sheet OS-A-11.

For Details T and W, Section B-B and Grating Splice Details, see Base Sheet OS-A-10.
For Details D, F, G and P and Handrail Splice Details, see Base Sheet OS-A-11.

Structure Number	Station	a	b	c	d	e	Walkway Grating and Handrail Lengths
9S100I057L52.8	1532+00	8'	57'	15'	-	-	57'

NUMBER	REVISION	DATE

REVISIONS		ILLINOIS DEPARTMENT OF TRANSPORTATION
NAME	DATE	
		<p align="center">OVERHEAD SIGN STRUCTURES ALTERNATE WALKWAY DETAILS</p> <p>SCALE: VERT. NONE HORIZ. DATE</p> <p>DRAWN BY CNH CHECKED BY</p>

PLOT DATE = 12/13/2006
 FILE NAME = c:\nrc\secta\98950\98950.dwg
 PLOT SCALE = 50.0000 / 1 IN.
 USER NAME = haden

F.A. RTE.	SECTION	COUNTY	TOTAL SHEETS	SHEET NO.
*	**	WILLIAMSON	917	760
STA. TO STA.				
FED. ROAD DIST. NO. ILLINOIS FED. AID PROJECT				
* I-57, & OLD IL 13 (FAU 9629)				
** (X1-6-2)VB-2,(X1-6)HBK-2				

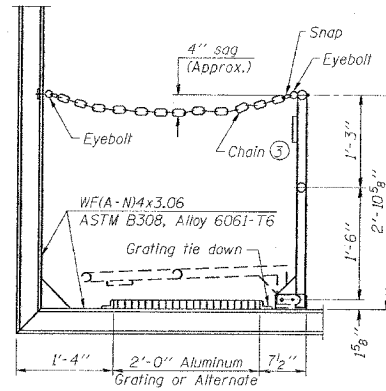

SIDE ELEVATION
(Showing safety chain w/o sign)

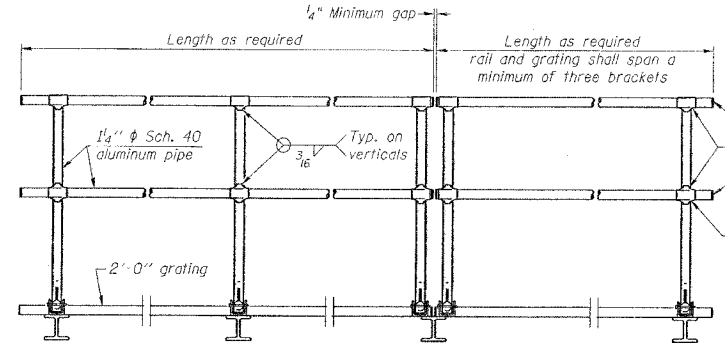

FRONT ELEVATION

HANDRAIL DETAILS

Handrail pipe shall be ASTM B241, Alloy 6063-T6 or Alloy 6061-T6.

- ① Install standard force-fit end caps or weld 3/8" end plates with 3/8" c.f.w. and grind smooth. (All rail ends)
- ② Horizontal handrail member shall be continuous thru fitting. Provide 7/16" hole in fitting for 3/8" bolt. Field drill 7/16" hole in horizontal rail member. Provide locknut and two stainless steel washers for bolt. (Use 5/16" eyebolts in 7/16" holes on top rail at ends only.)

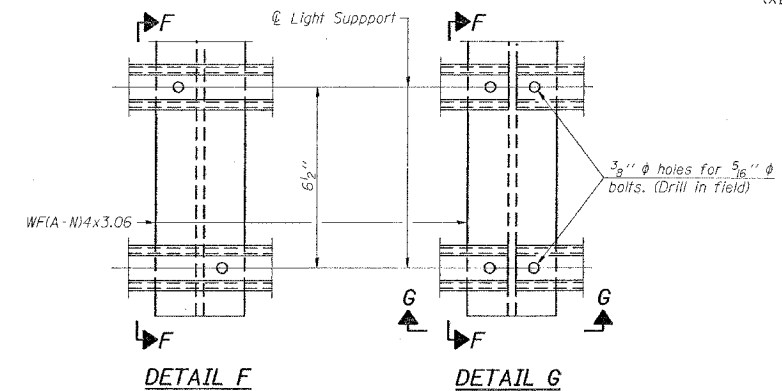

DETAIL F

DETAIL G

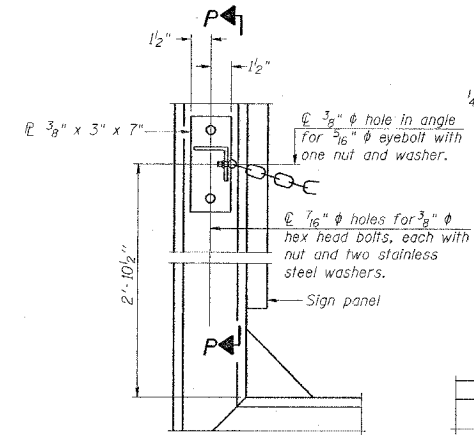

ALTERNATE SAFETY CHAIN ATTACHMENT
(With Sign Present)

Items not shown same as "Side Elevation" of "Handrail Details"

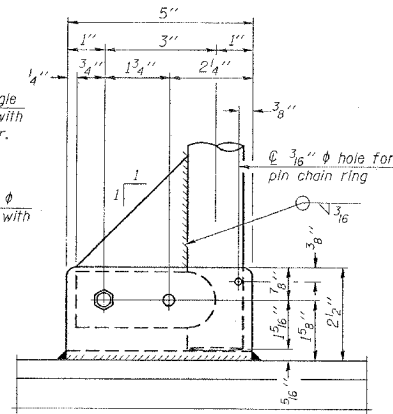

SIDE ELEVATION

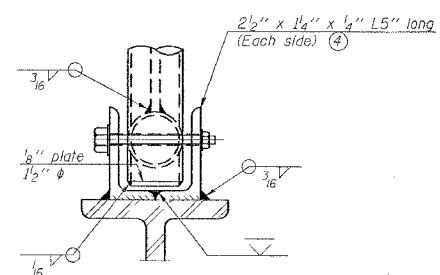

FRONT ELEVATION

See "Elevation" of right for dimensions.

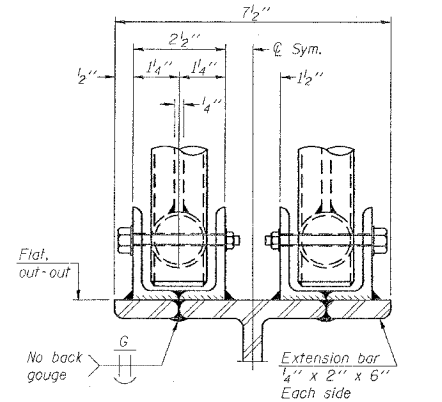

ELEVATION AT HANDRAIL JOINT ④

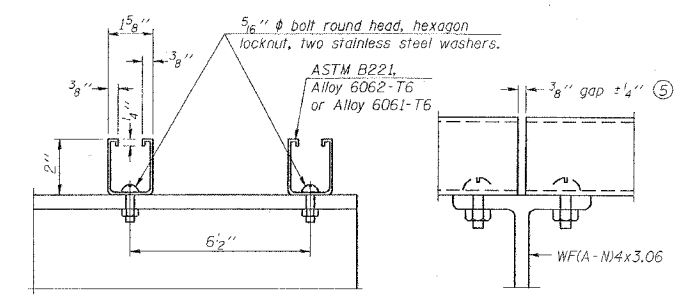

SECTION F-F

SECTION G-G

LIGHTING FIXTURE MOUNTS (IF REQUIRED)

- ⑤ Field cut ends of light support channels shall be free of burrs or hazardous projections and coated with zinc-rich primer or equivalent.

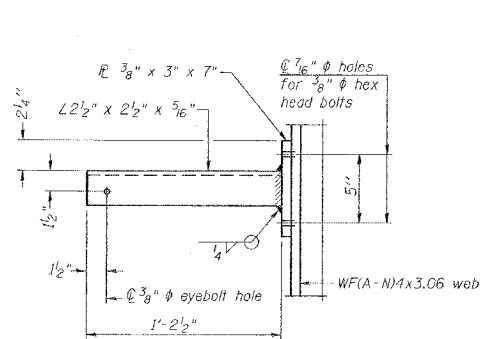

SECTION P-P

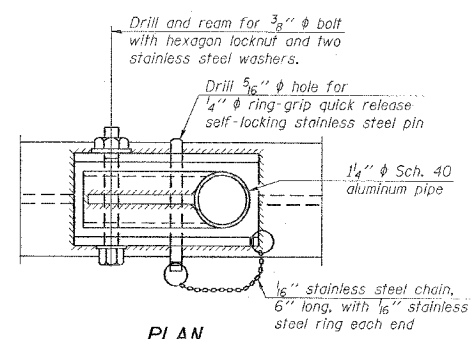

PLAN DETAIL E HANDRAIL HINGE

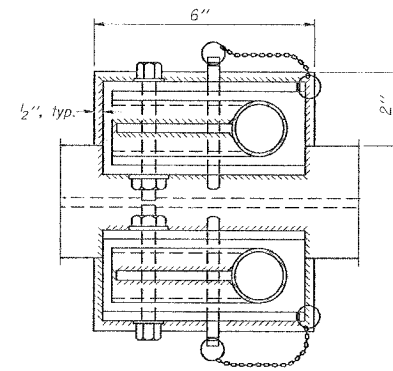

PLAN AT HANDRAIL JOINT

Details not shown same as "PLAN"

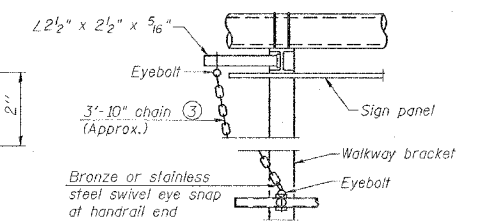

ALTERNATE SAFETY CHAIN ATTACHMENT

Details not shown similar to "Safety Chain" Details (Walkway omitted for clarity)

- ③ 3/16" galvanized steel chain, approximately 12 links per foot. Chain to be hot dip galvanized after manufacture and suitable for prolonged exterior exposure. Alternate materials may be substituted with the Engineer's approval.
- ④ Extrusions may be used in lieu of the details shown, with approval of the Engineer.

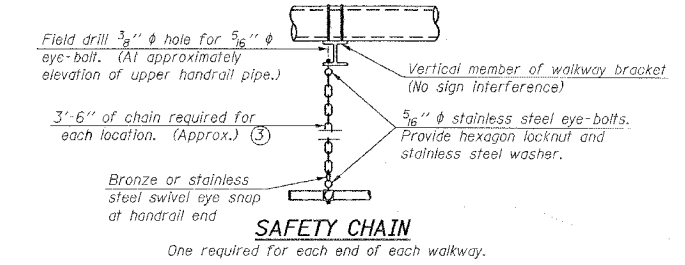

SAFETY CHAIN

One required for each end of each walkway.

NUMBER	REVISION	DATE

REVISIONS		ILLINOIS DEPARTMENT OF TRANSPORTATION
NAME	DATE	
		OVERHEAD SIGN STRUCTURES ALUMINUM HANDRAIL DETAILS SCALE: VERT. NONE HORIZ. DATE DRAWN BY CNH CHECKED BY

DATE = 10/12/2006
 FILE NAME = c:\p06\projects\98950\98950.dwg
 USER NAME = j...

F.A. RTE.	SECTION	COUNTY	TOTAL SHEETS	SHEET NO.
*	**	WILLIAMSON	917	761
STA.		TO STA.		
FED. ROAD DIST. NO.	ILLINOIS	FED. AID PROJECT		
* I-57, & OLD IL 13 (FAU 9629)				
** (X1-6-2)VB-2,(X1-6)HBK-2				

* Center of horizontal to center of splice dimension may vary. Verify before drilling holes in mounting tube.

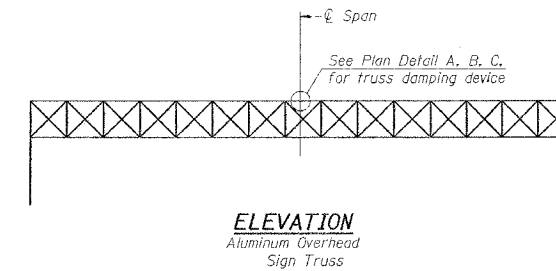
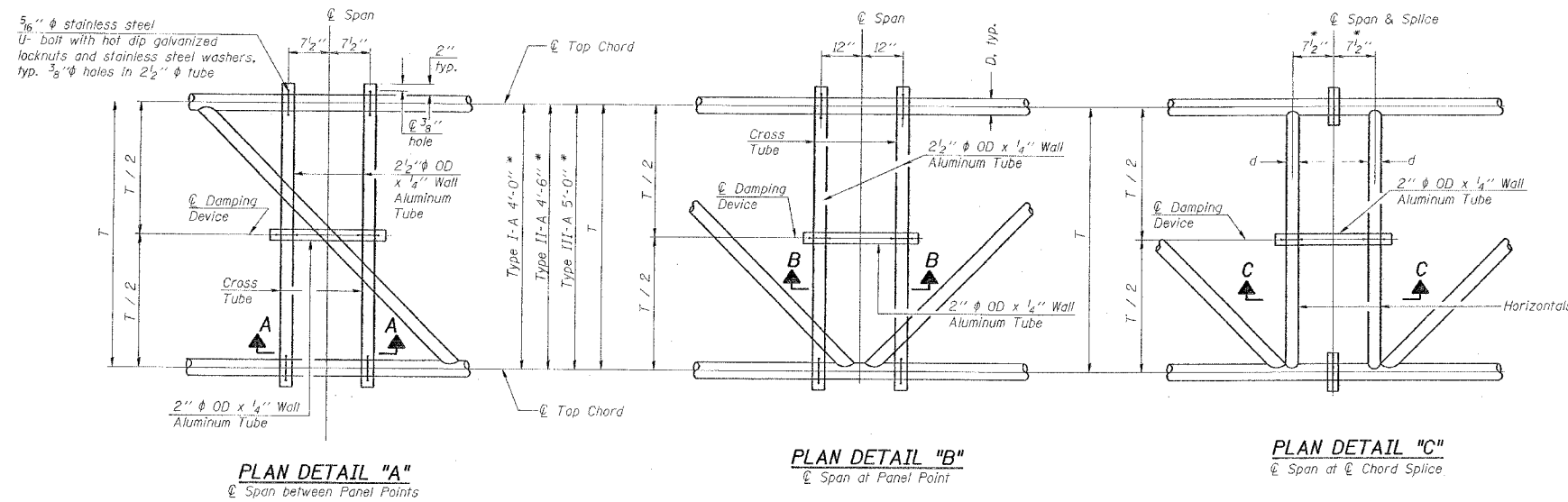

NOTES
 Damper: One damper per truss.
 (31 lbs. Stockbridge-Type Aluminum)
 Cost included in Overhead Sign Structure...
 Materials: Aluminum tubes shall be ASTM B221 alloy 6061 temper T6. Cost included in Overhead Sign Structure...

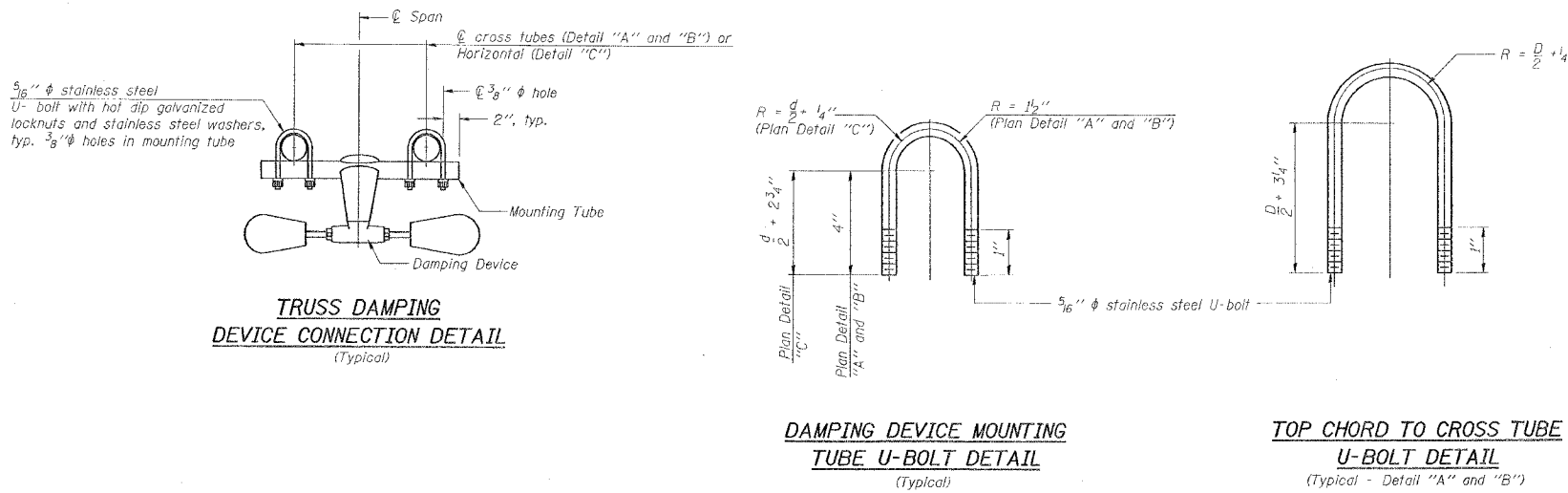
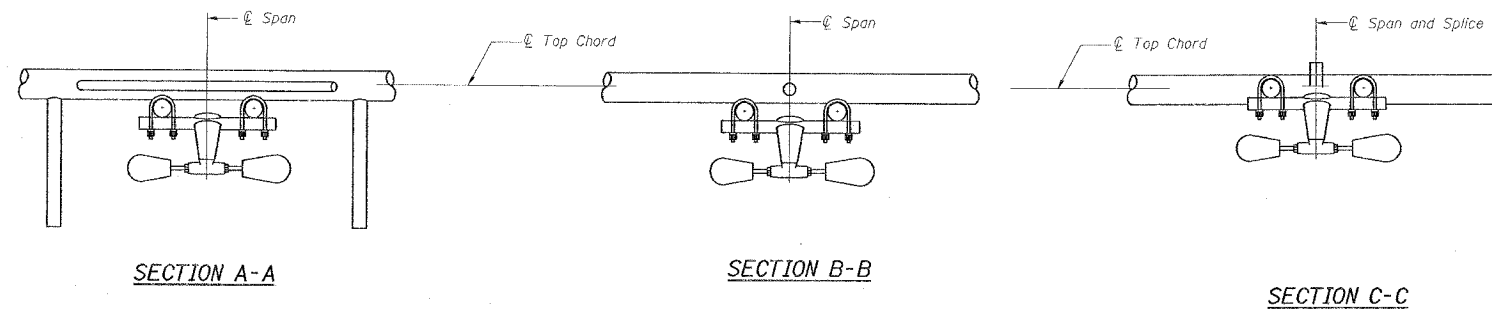

REVISIONS	
NAME	DATE

ILLINOIS DEPARTMENT OF TRANSPORTATION
OVERHEAD SIGN STRUCTURE
DAMPING DEVICE

SCALE: VERT. NONE
 HORIZ. DATE

DRAWN BY CNH
 CHECKED BY

F.A. RTE.	SECTION	COUNTY	TOTAL SHEETS	SHEET NO.
*	**	WILLIAMSON	917	762
STA. TO STA.				
FED. ROAD DIST. NO. ILLINOIS FED. AID PROJECT				
* I-57, & OLD IL 13 (FAU 9629)				
** (X1-6-2)VB-2,(X1-6)HBK-2				

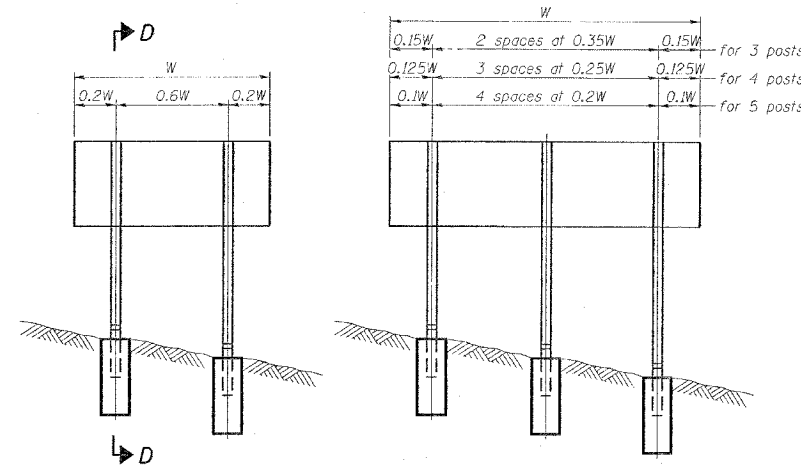

ELEVATION

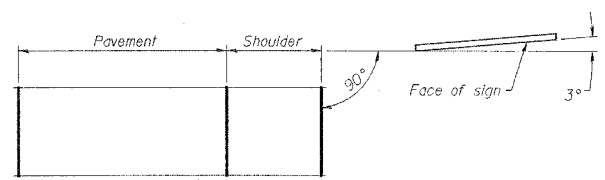

LOCATION SKETCH

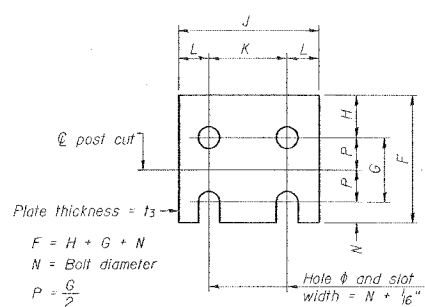

FUSE PLATE DETAIL
(Install with notches down.)

FUSE PLATE DATA		
N = Bolt Diameter	G	H
1/2"	2"	1 1/8"
5/8"	2 1/4"	1 1/4"
3/4"	2 1/2"	1 3/8"
7/8"	2 3/4"	1 1/2"
1"	3"	1 5/8"
1 1/8"	3 1/4"	1 3/4"

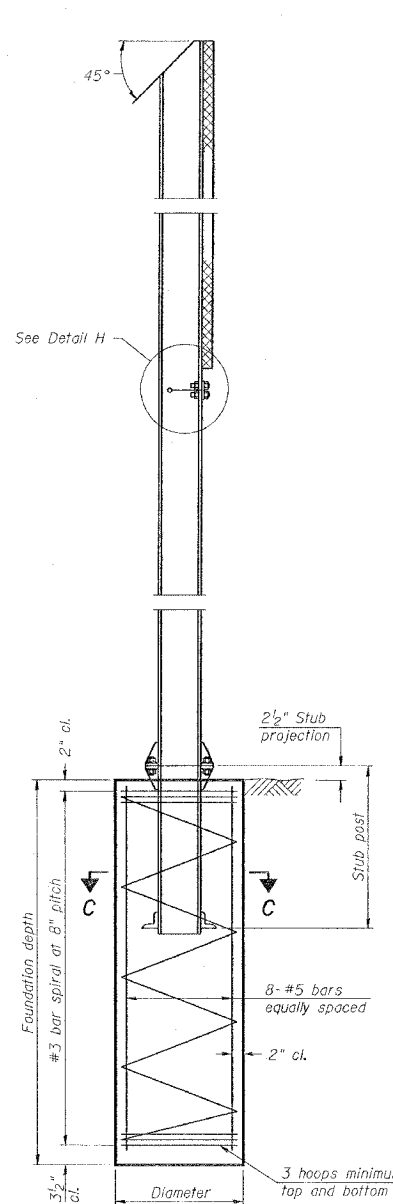

SECTION D-D

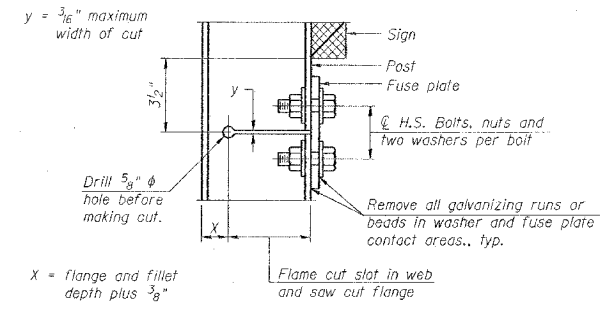

DETAIL H

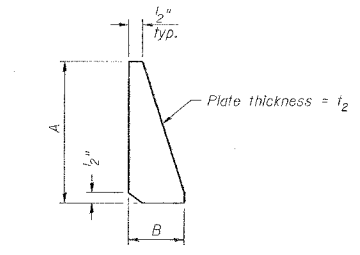

STIFFENER PLATE DETAIL
(See table for dimensions.)

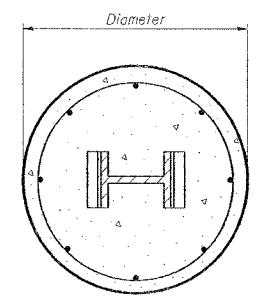

SECTION C-C

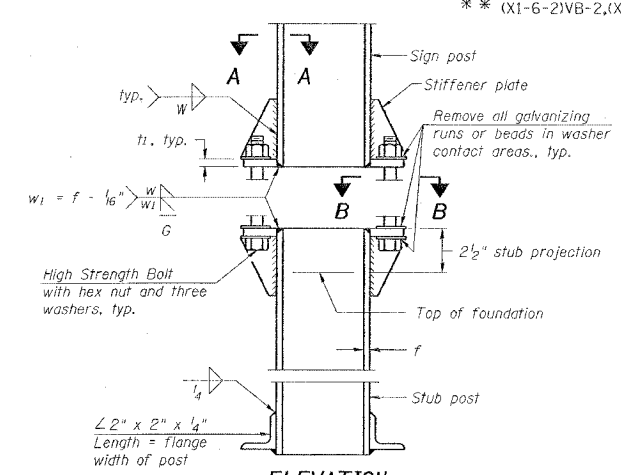

ELEVATION SIGN POST & STUB POST

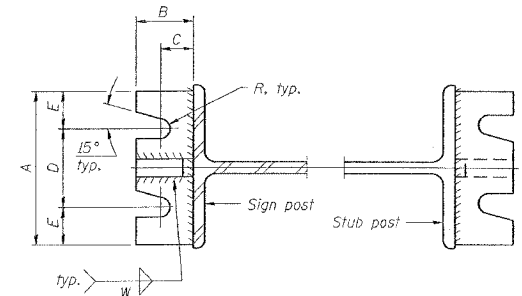

SECTION A-A

SECTION B-B

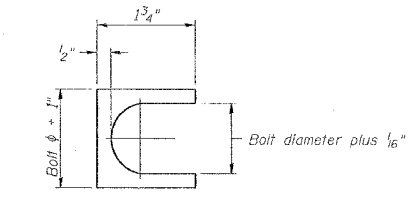

SHIM DETAIL

Furnish two 0.01" thick and two 0.03" thick stainless steel or brass (ASTM B36) shims per post.

GENERAL NOTES

Posts shall be plumbed by using shims with post-to-stub post connection bolts snug tight only. Final tightening of all High Strength Bolts shall be in accordance with Article 505.04(FX3), and threads at the junction of the bolt and nut shall be burred or center punched to prevent the nut from loosening.

LOADING: 80 m.p.h. wind with 30% gust factor, normal to sign.

DESIGN STRESSES:
Structural steel - 20,000 p.s.i.
Reinforcing steel - 20,000 p.s.i.
Concrete - 1,400 p.s.i.
Footing soil pressure - 2,000 p.s.f.

After fabrication, the post, fuse plate and upper 6", min. of the stub post shall be hot-dip galvanized in accordance with AASHTO M311. All bolts, nuts and washers shall be hot-dip galvanized in accordance with AASHTO M232.

Work this sheet with Base Sheet BAW-A-2.

(Sheet 1 of 2)

REVISIONS		ILLINOIS DEPARTMENT OF TRANSPORTATION
NAME	DATE	
		<p align="center">BREAK-AWAY WIDE FLANGE STEEL SIGN POST DETAILS</p> <p>SCALE: VERT. NONE HORIZ. DATE</p> <p align="right">DRAWN BY CNH CHECKED BY</p>

PLT DATE = 10/12/2005
FILE NAME = c:\pds\meca\pds\982802\old13\old13p15.dgn
PLOT SCALE = 80.0000 / IN.
USER NAME = hanson

NUMBER	REVISION	DATE

F.A. RTE.	SECTION	COUNTY	TOTAL SHEETS	SHEET NO.
*	**	WILLIAMSON	917	763
STA.		TO STA.		
FED. ROAD DIST. NO.		ILLINOIS FED. AID PROJECT		
* I-57, & OLD IL 13 (FAU 9629)				
** (X1-6-2)VB-2,(X1-6)HBK-2				

POST	CONCRETE FOUNDATION TABLE						POST TO STUB POST CONNECTION DATA										FUSE PLATE DATA					
	Diameter	Foundation Minimum Depth	Concrete (1) (cu. yds.)	Reinforcement Vertical Bars Length	Bar Spirals Diameter	lbs. (2)	Stub Post Length	Bolt Size	A	B	C	D	E	t ₁	t ₂	R	W	J	K	L	t ₃	
W6x9	2'-0"	6'-0"	0.70	5'-9"	1'-8 1/2"	79'-0"	78	2'-3"	5/8" x 3/4"	6"	2 1/4"	1 1/4"	3 1/2"	1 1/4"	3/4"	1/2"	5/32"	1/4"	4"	2 1/4"	7/8"	1/4"
W6x15	2'-0"	6'-0"	0.70	5'-9"	1'-8 1/2"	79'-0"	78	2'-6"	5/8" x 3/4"	6"	2 1/4"	1 1/4"	3 1/2"	1 1/4"	3/4"	1/2"	5/32"	1/4"	6"	3 1/2"	1 1/4"	3/8"
W8x18	2'-0"	6'-0"	0.70	5'-9"	1'-8 1/2"	79'-0"	78	2'-6"	3/4" x 3/4"	6"	2 1/2"	1 3/8"	3 1/4"	1 3/8"	1"	1/2"	5/32"	5/16"	5 1/4"	2 3/4"	1 1/4"	3/8"
W10x22	2'-6"	6'-6"	1.18	6'-3"	2'-2 1/2"	105'-0"	92	3'-0"	3/4" x 3/4"	6"	2 1/2"	1 3/8"	3 1/4"	1 3/8"	1"	1/2"	5/32"	5/16"	5 3/4"	2 3/4"	1 1/2"	1/2"
W10x26	2'-6"	7'-0"	1.27	6'-9"	2'-2 1/2"	112'-0"	98	3'-0"	7/8" x 4"	7"	2 3/4"	1 1/2"	4"	1 1/2"	1"	3/4"	5/32"	3/8"	5 3/4"	2 3/4"	1 1/2"	5/8"
W12x26	2'-6"	7'-9"	1.41	7'-6"	2'-2 1/2"	119'-0"	107	3'-0"	7/8" x 4"	7"	2 3/4"	1 1/2"	4"	1 1/2"	1"	3/4"	5/32"	3/8"	6 1/2"	3 1/2"	1 1/2"	5/8"
W14x30	3'-0"	7'-3"	1.90	7'-0"	2'-8 1/2"	145'-0"	113	3'-0"	7/8" x 4"	7"	2 3/4"	1 1/2"	4"	1 1/2"	1"	3/4"	5/32"	3/8"	6 3/4"	3 1/2"	1 5/8"	1/2"
W14x38	3'-0"	8'-0"	2.09	7'-9"	2'-8 1/2"	153'-0"	122	3'-6"	1" x 4 1/2"	7 1/2"	3"	1 3/4"	4"	1 3/4"	1 1/4"	3/4"	11/32"	3/8"	6 3/4"	3 1/2"	1 5/8"	1/2"
W16x45	3'-0"	8'-6"	2.23	8'-3"	2'-8 1/2"	162'-0"	130	3'-6"	1" x 4 1/2"	7 1/2"	3"	1 3/4"	4"	1 3/4"	1 1/4"	3/4"	11/32"	3/8"	7"	3 1/2"	1 3/4"	1/2"

*Dimensional changes required for varying site conditions shall be approved by the Engineer.

POST	FUSE PLATE BOLT SIZE												
	Sign Depth												
	4'-0"	5'-0"	6'-0"	7'-0"	8'-0"	9'-0"	10'-0"	11'-0"	12'-0"	13'-0"	14'-0"	15'-0"	16'-0"
W6x9	1/2" x 1 1/2"	1/2" x 1 1/2"	1/2" x 1 1/2"	5/8" x 1 3/4"	5/8" x 1 3/4"	5/8" x 1 3/4"	5/8" x 1 3/4"	5/8" x 1 3/4"	5/8" x 1 3/4"	5/8" x 1 3/4"	5/8" x 1 3/4"	5/8" x 1 3/4"	5/8" x 1 3/4"
W6x15	1/2" x 1 3/4"	1/2" x 1 3/4"	5/8" x 2"	5/8" x 2"	5/8" x 2"	5/8" x 2"	5/8" x 2"	5/8" x 2"	5/8" x 2"	5/8" x 2"	5/8" x 2"	5/8" x 2"	5/8" x 2"
W8x18	1/2" x 1 3/4"	1/2" x 1 3/4"	5/8" x 2"	5/8" x 2"	5/8" x 2"	5/8" x 2"	5/8" x 2"	5/8" x 2"	5/8" x 2"	5/8" x 2"	5/8" x 2"	5/8" x 2"	5/8" x 2"
W10x22	1/2" x 2"	1/2" x 2"	5/8" x 2"	5/8" x 2"	5/8" x 2"	5/8" x 2"	5/8" x 2"	5/8" x 2"	5/8" x 2"	5/8" x 2"	5/8" x 2"	5/8" x 2"	5/8" x 2"
W10x26	1/2" x 2"	1/2" x 2"	5/8" x 2"	5/8" x 2"	5/8" x 2"	5/8" x 2"	5/8" x 2"	5/8" x 2"	5/8" x 2"	5/8" x 2"	5/8" x 2"	5/8" x 2"	5/8" x 2"
W12x26	1/2" x 2"	1/2" x 2"	5/8" x 2"	5/8" x 2"	5/8" x 2"	5/8" x 2"	5/8" x 2"	5/8" x 2"	5/8" x 2"	5/8" x 2"	5/8" x 2"	5/8" x 2"	5/8" x 2"
W14x30	1/2" x 2"	1/2" x 2"	5/8" x 2"	5/8" x 2"	5/8" x 2"	5/8" x 2"	5/8" x 2"	5/8" x 2"	5/8" x 2"	5/8" x 2"	5/8" x 2"	5/8" x 2"	5/8" x 2"
W14x38	1/2" x 2"	1/2" x 2"	5/8" x 2"	5/8" x 2"	5/8" x 2"	5/8" x 2"	5/8" x 2"	5/8" x 2"	5/8" x 2"	5/8" x 2"	5/8" x 2"	5/8" x 2"	5/8" x 2"
W16x45	1/2" x 2"	1/2" x 2"	5/8" x 2"	5/8" x 2"	5/8" x 2"	5/8" x 2"	5/8" x 2"	5/8" x 2"	5/8" x 2"	5/8" x 2"	5/8" x 2"	5/8" x 2"	5/8" x 2"

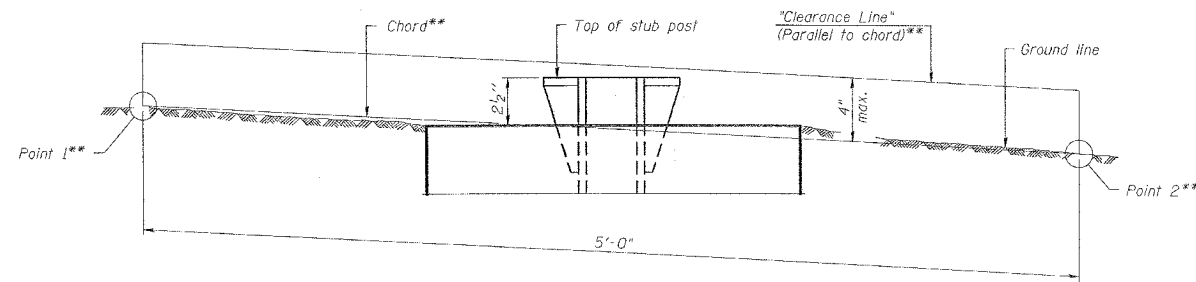

ELEVATION
GROUND LINE & STUB POST

** For all "Point 1" and "Point 2" locations, "Clearance Line" must be at or above top of stub post.

- (1) Quantity includes all concrete necessary for one foundation.
- (2) Includes reinforcement bars and spiral hooping for one foundation.

(Sheet 2 of 2)

NUMBER	REVISION	DATE

BAW-A-2 1-7-05

REVISIONS		ILLINOIS DEPARTMENT OF TRANSPORTATION
NAME	DATE	
		BREAK-AWAY WIDE FLANGE STEEL SIGN POST TABLES

SCALE: VERT. NONE
HORIZ. DATE
DRAWN BY CNH
CHECKED BY

F.A. RTE.	SECTION	COUNTY	TOTAL SHEETS	SHEET NO.
*	**	WILLIAMSON	917	764

STA. TO STA.
 ILLINOIS FED. AID PROJECT
 * I-57, & OLD IL 13 (FAU 9629)
 ** (X1-6-2)VB-2,(X1-6)HBK-2

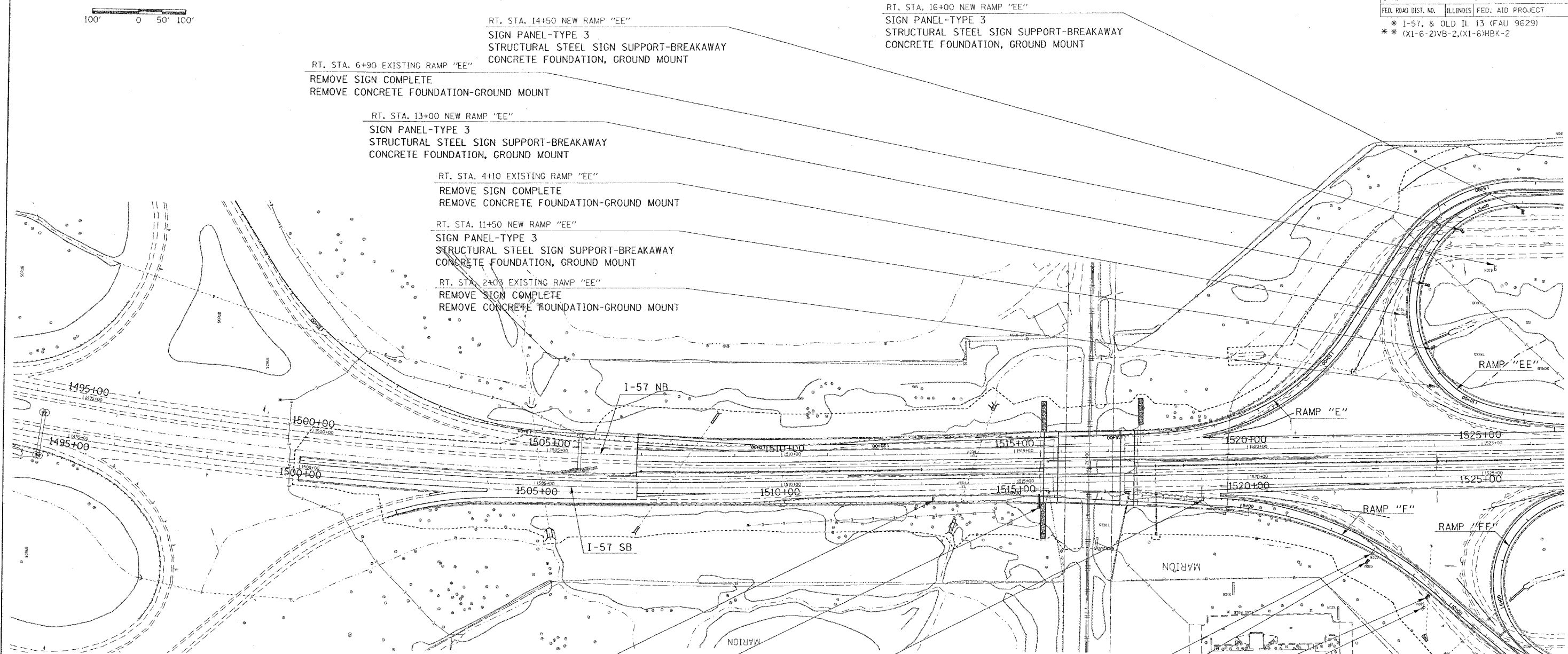
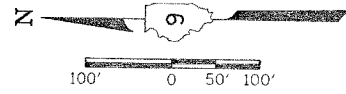

RT. STA. 6+90 EXISTING RAMP "EE"
 REMOVE SIGN COMPLETE
 REMOVE CONCRETE FOUNDATION-GROUND MOUNT

RT. STA. 13+00 NEW RAMP "EE"
 SIGN PANEL-TYPE 3
 STRUCTURAL STEEL SIGN SUPPORT-BREAKAWAY
 CONCRETE FOUNDATION, GROUND MOUNT

RT. STA. 4+10 EXISTING RAMP "EE"
 REMOVE SIGN COMPLETE
 REMOVE CONCRETE FOUNDATION-GROUND MOUNT

RT. STA. 11+50 NEW RAMP "EE"
 SIGN PANEL-TYPE 3
 STRUCTURAL STEEL SIGN SUPPORT-BREAKAWAY
 CONCRETE FOUNDATION, GROUND MOUNT

RT. STA. 2+00 EXISTING RAMP "EE"
 REMOVE SIGN COMPLETE
 REMOVE CONCRETE FOUNDATION-GROUND MOUNT

RT. STA. 16+00 NEW RAMP "EE"
 SIGN PANEL-TYPE 3
 STRUCTURAL STEEL SIGN SUPPORT-BREAKAWAY
 CONCRETE FOUNDATION, GROUND MOUNT

RT. STA. 1513+20
 REMOVE SIGN COMPLETE
 REMOVE CONCRETE FOUNDATION-GROUND MOUNT

RT. STA. 2+60 EXISTING RAMP "F"
 REMOVE SIGN COMPLETE
 REMOVE CONCRETE FOUNDATION-GROUND MOUNT

STA. 1515+50
 SIGN PANEL-TYPE 3
 DRILLED SHAFT CONCRETE FOUNDATIONS
 OVERHEAD SIGN STRUCTURE-CANTILEVER, TYPE II-C-A (36" X 5'-6")
 OVERHEAD SIGN WALKWAY, CANTILEVER, TYPE A

RT. STA. 8+00 NEW RAMP "F"
 SIGN PANEL-TYPE 3
 STRUCTURAL STEEL SIGN SUPPORT-BREAKAWAY
 CONCRETE FOUNDATION, GROUND MOUNT

RT. STA. 6+40 EXISTING RAMP "F"
 REMOVE SIGN COMPLETE
 REMOVE CONCRETE FOUNDATION-GROUND MOUNT

STA. 1519+00
 REMOVE SIGN COMPLETE
 REMOVE OVERHEAD SIGN STRUCTURE-CANTILEVER
 REMOVE CONCRETE FOUNDATION-OVERHEAD

RT. STA. 9+50 NEW RAMP "F"
 SIGN PANEL-TYPE 3
 STRUCTURAL STEEL SIGN SUPPORT-BREAKAWAY
 CONCRETE FOUNDATION, GROUND MOUNT

RT. STA. 4+25 EXISTING RAMP "F"
 REMOVE SIGN COMPLETE
 REMOVE CONCRETE FOUNDATION-GROUND MOUNT

RT. STA. 11+50 NEW RAMP "F"
 SIGN PANEL-TYPE 3
 STRUCTURAL STEEL SIGN SUPPORT-BREAKAWAY
 CONCRETE FOUNDATION, GROUND MOUNT

REVISIONS	
NAME	DATE

ILLINOIS DEPARTMENT OF TRANSPORTATION

SIGN LOCATION
FAI-57 AND OLD IL 13 (9629)
 SHEET 1 OF 2

SCALE: VERT. 100
 HORIZ. DATE

DRAWN BY CNH
 CHECKED BY

PL DATE = 12/12/2005
 FILE NAME = c:\p\o\mets\d982802\old13\old13\sign
 USER NAME = hudson

F.A. RTE.	SECTION	COUNTY	TOTAL SHEETS	SHEET NO.
*	**	WILLIAMSON	917	765
STA.		TO STA.		
FED. ROAD DIST. NO.		ILLINOIS FED. AID PROJECT		
* I-57, & OLD IL 13 (FAU 9629)				
** (X1-6-2)VB-2,(X1-6)HBK-2				

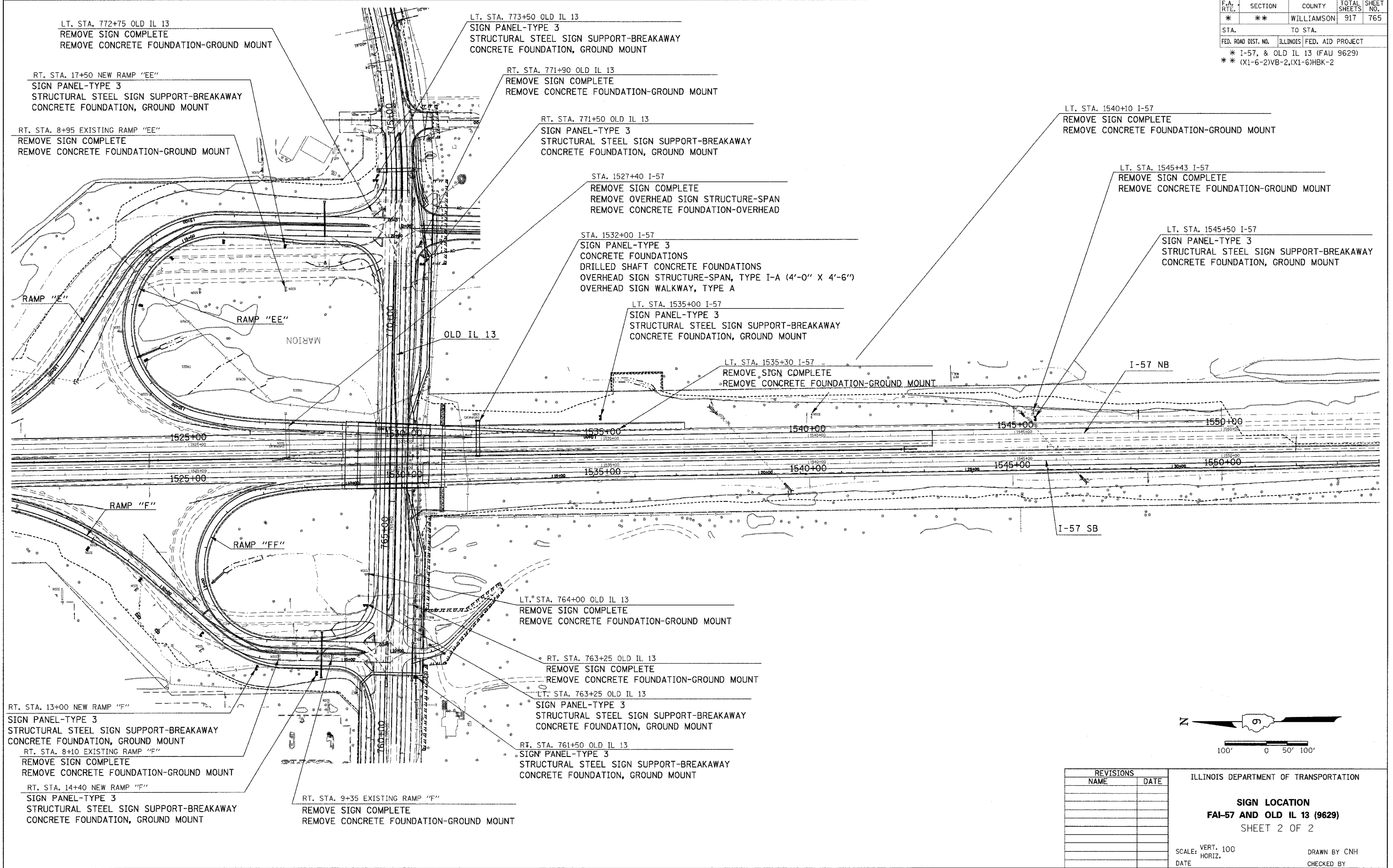

LT. STA. 772+75 OLD IL 13
REMOVE SIGN COMPLETE
REMOVE CONCRETE FOUNDATION-GROUND MOUNT

LT. STA. 773+50 OLD IL 13
SIGN PANEL-TYPE 3
STRUCTURAL STEEL SIGN SUPPORT-BREAKAWAY
CONCRETE FOUNDATION, GROUND MOUNT

RT. STA. 17+50 NEW RAMP "EE"
SIGN PANEL-TYPE 3
STRUCTURAL STEEL SIGN SUPPORT-BREAKAWAY
CONCRETE FOUNDATION, GROUND MOUNT

RT. STA. 771+90 OLD IL 13
REMOVE SIGN COMPLETE
REMOVE CONCRETE FOUNDATION-GROUND MOUNT

RT. STA. 8+95 EXISTING RAMP "EE"
REMOVE SIGN COMPLETE
REMOVE CONCRETE FOUNDATION-GROUND MOUNT

RT. STA. 771+50 OLD IL 13
SIGN PANEL-TYPE 3
STRUCTURAL STEEL SIGN SUPPORT-BREAKAWAY
CONCRETE FOUNDATION, GROUND MOUNT

LT. STA. 1540+10 I-57
REMOVE SIGN COMPLETE
REMOVE CONCRETE FOUNDATION-GROUND MOUNT

STA. 1527+40 I-57
REMOVE SIGN COMPLETE
REMOVE OVERHEAD SIGN STRUCTURE-SPAN
REMOVE CONCRETE FOUNDATION-OVERHEAD

LT. STA. 1545+43 I-57
REMOVE SIGN COMPLETE
REMOVE CONCRETE FOUNDATION-GROUND MOUNT

STA. 1532+00 I-57
SIGN PANEL-TYPE 3
CONCRETE FOUNDATIONS
DRILLED SHAFT CONCRETE FOUNDATIONS
OVERHEAD SIGN STRUCTURE-SPAN, TYPE I-A (4'-0" X 4'-6")
OVERHEAD SIGN WALKWAY, TYPE A

LT. STA. 1545+50 I-57
SIGN PANEL-TYPE 3
STRUCTURAL STEEL SIGN SUPPORT-BREAKAWAY
CONCRETE FOUNDATION, GROUND MOUNT

LT. STA. 1535+00 I-57
SIGN PANEL-TYPE 3
STRUCTURAL STEEL SIGN SUPPORT-BREAKAWAY
CONCRETE FOUNDATION, GROUND MOUNT

LT. STA. 1535+30 I-57
REMOVE SIGN COMPLETE
REMOVE CONCRETE FOUNDATION-GROUND MOUNT

LT. STA. 764+00 OLD IL 13
REMOVE SIGN COMPLETE
REMOVE CONCRETE FOUNDATION-GROUND MOUNT

RT. STA. 763+25 OLD IL 13
REMOVE SIGN COMPLETE
REMOVE CONCRETE FOUNDATION-GROUND MOUNT

LT. STA. 763+25 OLD IL 13
SIGN PANEL-TYPE 3
STRUCTURAL STEEL SIGN SUPPORT-BREAKAWAY
CONCRETE FOUNDATION, GROUND MOUNT

RT. STA. 761+50 OLD IL 13
SIGN PANEL-TYPE 3
STRUCTURAL STEEL SIGN SUPPORT-BREAKAWAY
CONCRETE FOUNDATION, GROUND MOUNT

RT. STA. 13+00 NEW RAMP "F"
SIGN PANEL-TYPE 3
STRUCTURAL STEEL SIGN SUPPORT-BREAKAWAY
CONCRETE FOUNDATION, GROUND MOUNT

RT. STA. 8+10 EXISTING RAMP "F"
REMOVE SIGN COMPLETE
REMOVE CONCRETE FOUNDATION-GROUND MOUNT

RT. STA. 14+40 NEW RAMP "F"
SIGN PANEL-TYPE 3
STRUCTURAL STEEL SIGN SUPPORT-BREAKAWAY
CONCRETE FOUNDATION, GROUND MOUNT

RT. STA. 9+35 EXISTING RAMP "F"
REMOVE SIGN COMPLETE
REMOVE CONCRETE FOUNDATION-GROUND MOUNT

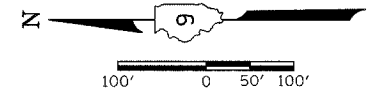

REVISIONS		ILLINOIS DEPARTMENT OF TRANSPORTATION
NAME	DATE	
		SIGN LOCATION FAI-57 AND OLD IL 13 (9629) SHEET 2 OF 2
SCALE:	VERT. 100 HORIZ.	DRAWN BY CNH CHECKED BY

PLOT DATE = 12/13/2005
FILE NAME = c:\p\proj\mca\98950\2882\oldil13\oldil13.dgn
PLOT SCALE = 100.0000 / IN.
USER NAME = hueden

F.A. RTE.	SECTION	COUNTY	TOTAL SHEETS	SHEET NO.
*	**	WILLIAMSON	917	767
STA.		TO STA.		
FED. ROAD DIST. NO.		ILLINOIS FED. AID PROJECT		
* I-57, & OLD IL 13 (FAU 9629)				
** (X1-6-2)VB-2,(X1-6)HBK-2				

**SIGN 2
NB I-57**

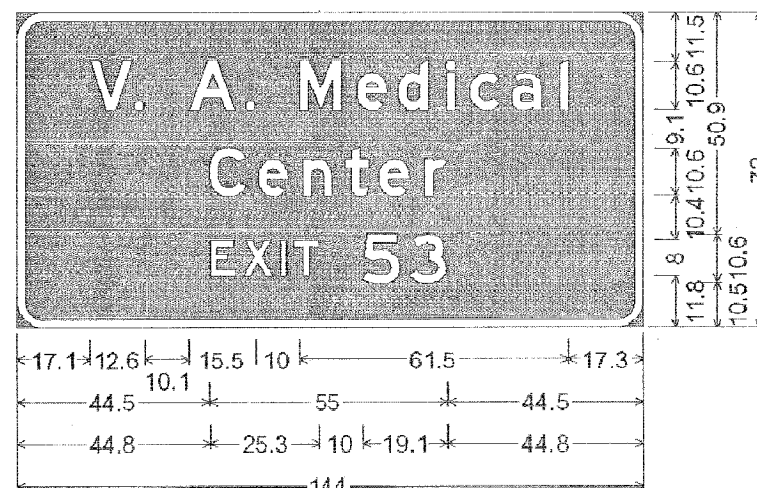

6.0" Radius, 2.0" Border, White on Green;
 "V." E Mod; "A." E Mod; "Medical" E Mod;
 "Center" E Mod; "EXIT" E Mod; "53" E Mod;
 Table of widths and spaces.

17.1	V	9.8	0.8	2.1	10.0	A	10.6	2.8	2.1						
10.0	M	9.9	3.6	6.9	2.5	7.0	4.0	2.0	3.4	6.8	2.5	6.9	4.0	2.0	17.3
44.5	C	8.5	2.9	6.9	3.4	6.9	3.0	5.4	2.4	7.0	3.3	5.3	44.5		
44.8	E	5.9	1.6	7.0	1.6	1.6	6.0	10.0	8.5	2.1	8.6	44.8			

NB I-57 #3

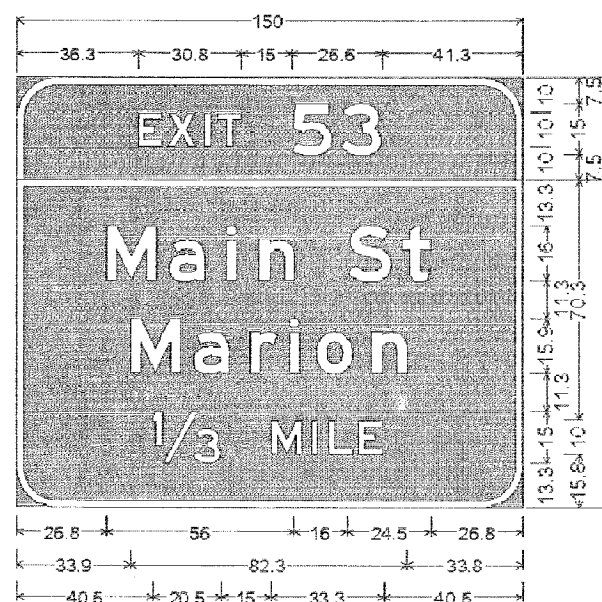

12.0" Radius, 2.0" Border, White on Green;
 "EXIT" E Mod 2K; "53" E Mod 2K;
 12.0" Radius, 2.0" Border, White on Green;
 "Main St" E Mod 2K; "Marion" E Mod 2K;
 "1/3" E Mod 2K; "MILE" E Mod 2K;
 Table of widths and spaces.

36.3	E	7.4	1.4	8.6	2.1	2.0	1.9	7.4	15.0	12.1	2.4	12.1	41.3
26.8	M	14.9	4.0	10.5	6.4	3.3	6.3	10.5	16.0	13.0	3.3	8.3	26.8
33.9	M	14.9	4.0	10.5	6.4	8.0	3.9	3.1	5.0	10.9	5.0	10.5	33.9
40.6	1/3	20.5	15.0	9.3	2.8	2.0	2.8	7.4	1.6	7.4	40.6		

SB I-57 #4

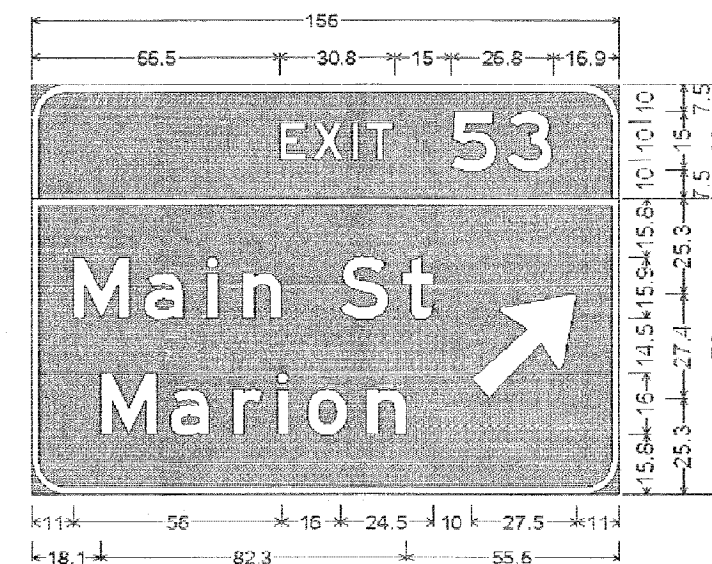

9.0" Radius, 2.0" Border, White on Green;
 "EXIT" E Mod 2K; "53" E Mod 2K;
 9.0" Radius, 2.0" Border, White on Green;
 "Main St" E Mod 2K; "Marion" E Mod 2K;
 Table of widths and spaces.

66.5	E	7.4	1.4	8.8	2.0	2.0	1.8	7.4	15.0	12.1	2.5	12.1	17.0
11.0	M	14.9	4.0	10.5	6.5	3.1	6.5	10.5	16.0	13.0	3.1	8.4	
10.0	↗	27.5	11.0										
18.1	M	14.9	4.0	10.5	6.5	9.0	3.8	3.3	4.9	10.9	4.9	10.5	55.8

REVISIONS		ILLINOIS DEPARTMENT OF TRANSPORTATION
NAME	DATE	
		SIGN PANELS
SCALE: VERT. NO SCALE	DATE	DRAWN BY
		CHECKED BY

#6 EB Old IL-13

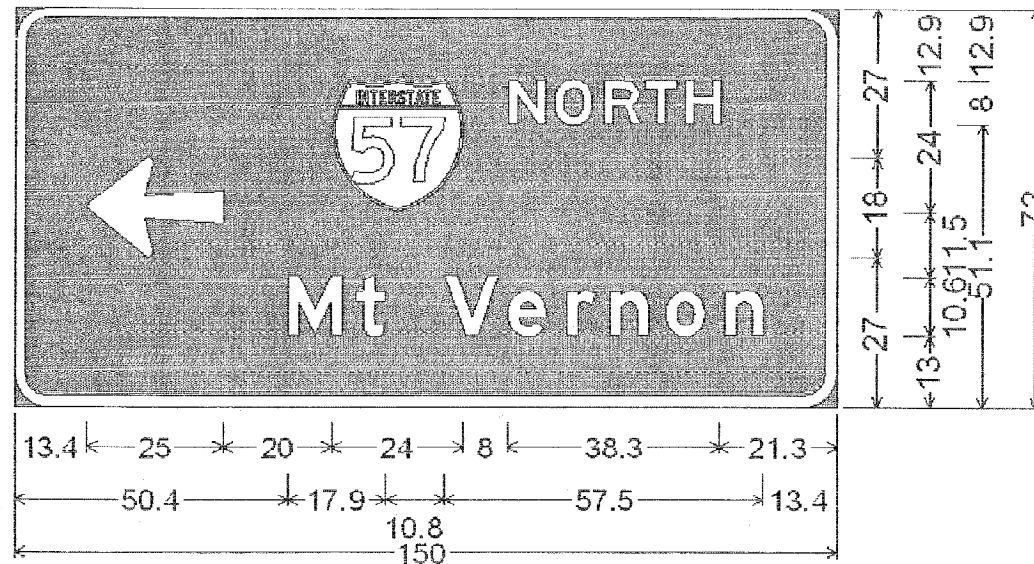

6.0" Radius, 2.0" Border, White on Green:
 "NORTH" E Mod 2K; "Mt Vernon" E Mod 2K;
 Table of widths and spaces.

13.4	←	25.0	20.0	24.0										
					N	O	R	T	H					
		8.0	6.5	1.9	6.8	1.9	6.4	0.9	5.9	1.5	6.4	21.4		
50.4	M	t												
		9.9	2.5	5.5										
					V	e	r	n	e	n				
		10.8	9.8	1.5	7.0	3.4	5.3	2.5	7.1	3.3	7.3	3.3	7.0	13.4

CSa

#9 I-57 RAMP F

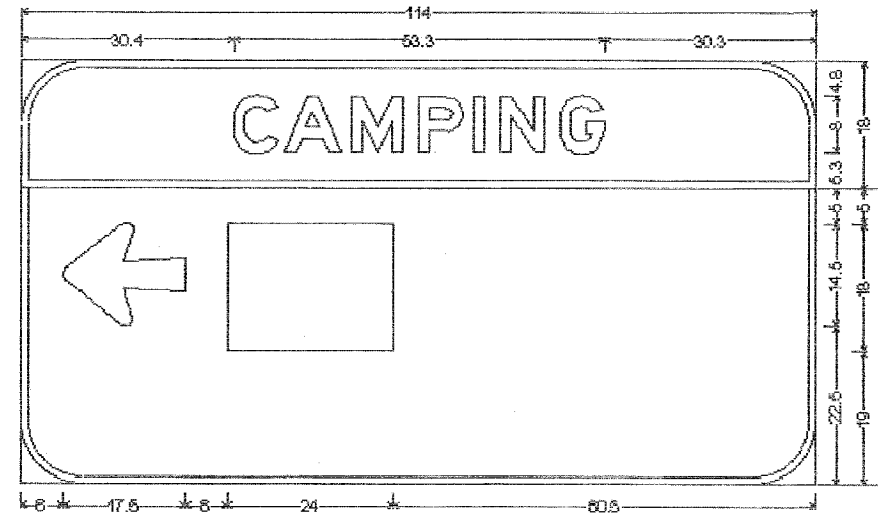

9.0" Radius, 1.0" Border, White on Blue;
 "CAMPING" E Mod 2K;
 9.0" Radius, 1.0" Border, White on Blue;
 Untitle1;
 Table of letter and object lefts.

C	A	M	P	I	N	G
30.4	37.8	47.4	57.0	64.9	68.8	77.1
←	□					
6.0	29.8					

GSb #10 RAMP F

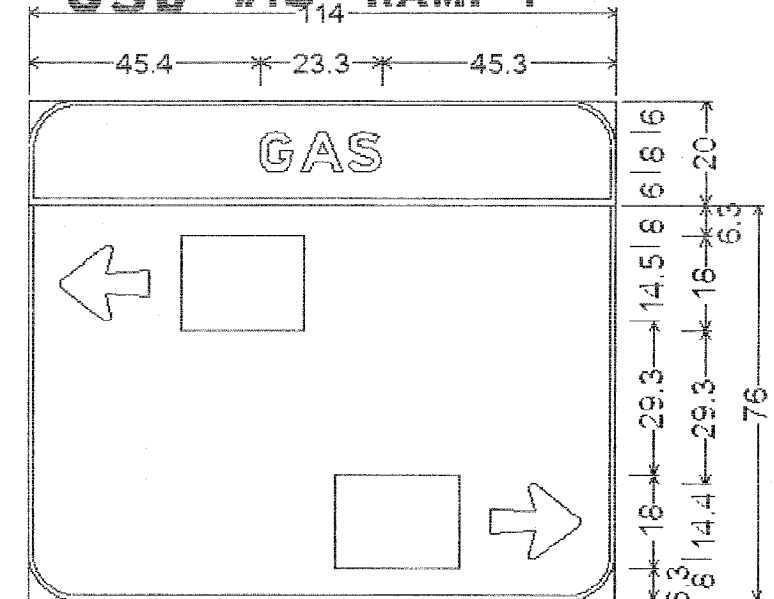

9.0" Radius, 1.0" Border, White on Blue;
 "GAS" E Mod 2K;
 9.0" Radius, 1.0" Border, White on Blue;
 Untitle1; Untitle1;
 Table of widths and spaces.

45.4	G	A	S	45.3	
	6.4	1.1	8.1	1.3	6.4
6.3	←	□			
	17.5	6.0	24.0	60.3	
59.8	□	←			
	24.0	6.0	17.5	6.8	

F.A. RTE.	SECTION	COUNTY	TOTAL SHEETS	SHEET NO.
*	**	WILLIAMSON	917	770
STA.		TO STA.		
FED. ROAD DIST. NO.	ILLINOIS FED. AID PROJECT			

* I-57, & OLD IL 13 (FAU 9629)
 ** (X1-6-2)VB-2,(X1-6)HBK-2

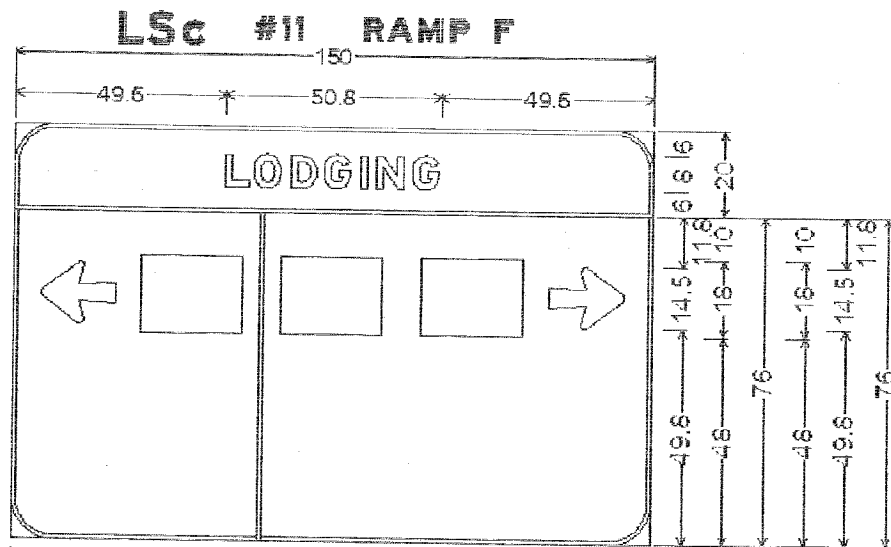

17.5 6 24 24 9 24 6 17.5
 6.5" Radius, 1.0" Border, White on Blue;

"LODGING" E Mod 2K;
 9.0" Radius, 1.0" Border, White on Blue;

Untitled1; Untitled1;

Table of widths and spaces.

49.6	L	6.0	0.9	D	5.8	1.9	D	5.5	1.5	G	6.5	2.0	I	1.5	2.3	N	6.5	1.9	G	6.5	49.6
6.5	←	17.5	6.0	□	24.0	4.0	1.0	4.0	24.0	9.0	□	24.0	6.0	→	17.5	6.5					

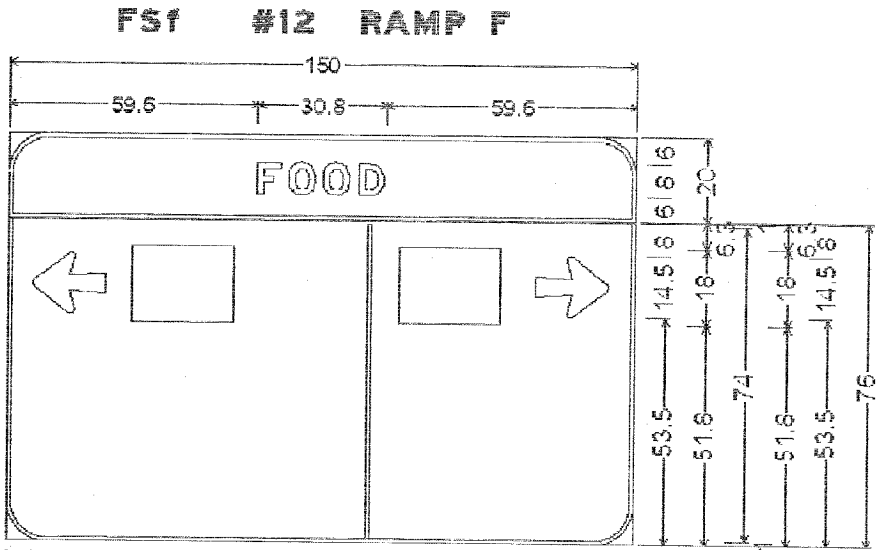

17.5 24 32 24 17.5
 9.0" Radius, 1.0" Border, White on Blue;

"FOOD" E Mod 2K;
 9.0" Radius, 1.0" Border, White on Blue;

Untitled1; Untitled1;

Table of widths and spaces.

59.6	F	5.0	1.4	D	6.6	1.6	D	6.8	1.9	D	6.5	59.6	
6.0	←	17.5	6.5	□	24.0	3.0	1.0	6.5	24.0	8.5	→	17.5	6.5

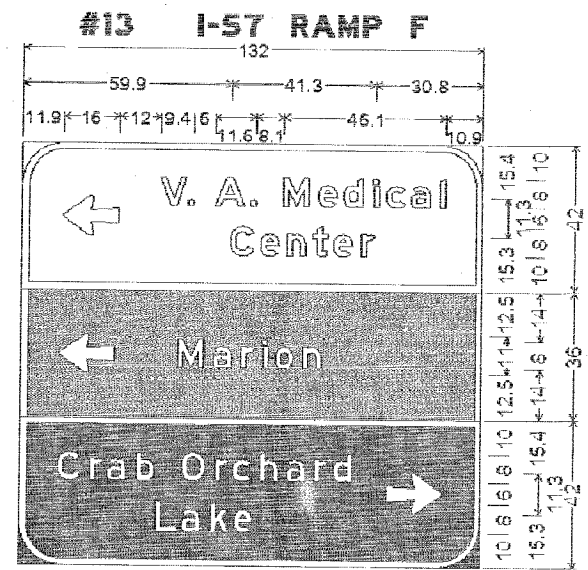

11.9 16 12 9.4 6 46.1 10.9
 11.6 8.1

12.0" Radius, 2.0" Border, White on Blue;
 "V." E Mod; "A." E Mod; "Medical" E Mod;
 "Center" E Mod;
 3.0" Radius, 2.0" Border, White on Green;
 "Marion" E Mod;
 12.0" Radius, 2.0" Border, White on Brown;
 "Crab" E Mod; "Orchard" E Mod; "Lake" E Mod;

Table of widths and spaces.

11.9	←	V	7.3	0.5	1.6	6.0	8.0	2.1	1.6					
8.0	H	e	5.1	1.9	5.1	3.1	1.5	2.5	5.1	1.9	a	b	i	10.9
59.9	C	6.4	2.1	5.3	2.4	5.3	2.1	4.1	1.9	5.1	2.5	4.0	30.9	
11.0	←	16.0												
18.0	H	e	5.3	3.0	3.9	1.9	1.5	2.5	5.3	2.5	5.1	46.0		
11.0	C	6.4	2.5	4.0	1.1	5.3	3.0	5.3						
7.9	D	6.6	2.8	3.9	1.3	5.0	2.5	5.3	2.4	5.1	3.1	4.0	1.1	5.3
10.0	→	11.0												
39.1	L	5.9	1.6	5.1	3.1	5.3	1.6	5.3	65.0					

REVISIONS	
NAME	DATE

ILLINOIS DEPARTMENT OF TRANSPORTATION

SIGN PANELS

SCALE: VERT. NO SCALE
 HORIZ. DATE

DRAWN BY
 CHECKED BY

PLT DATE = 10/12/2005
 FILE NAME = \\s0228262\c\d13\013sign.dgn
 PLOT SCALE = 50.0000 / IN.
 USER NAME = hsdgcn

F.A. RTE.	SECTION	COUNTY	TOTAL SHEETS	SHEET NO.
*	**	WILLIAMSON	917	771
STA.		TO STA.		
FED. ROAD DIST. NO.	ILLINOIS	FED. AID PROJECT		

* I-57, & OLD IL 13 (FAU 9629)
 ** (X1-6-2)VB-2,(X1-6)HBK-2

CSa
#14 I-57 RAMP EE

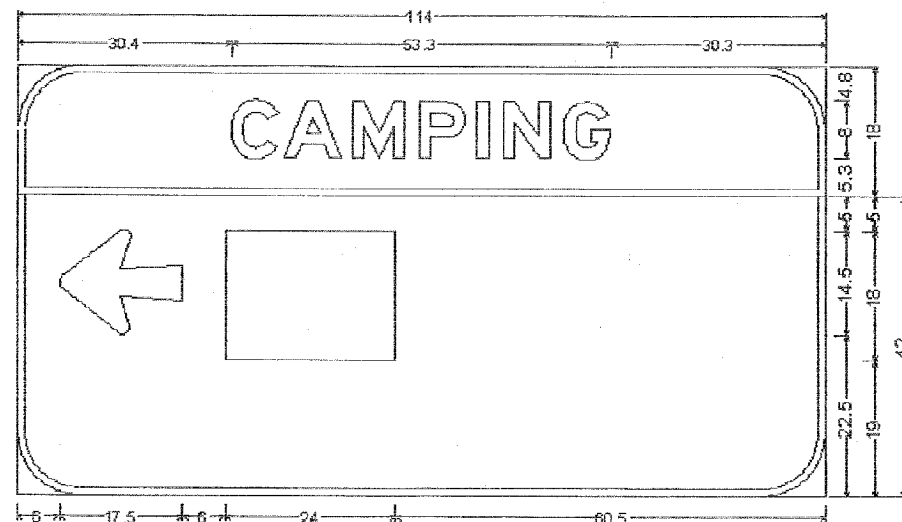

9.0" Radius, 1.0" Border, White on Blue;
 "CAMPING" E Mod 2K;
 9.0" Radius, 1.0" Border, White on Blue;
 Untitle1;

Table of widths and spaces.

C	A	M	P	I	N	G	S
30.4	6.5	0.9	8.1	1.4	7.5	2.3	6.4
6.0	17.5	6.0	24.0	60.5			

GSb #15 RAMP EE

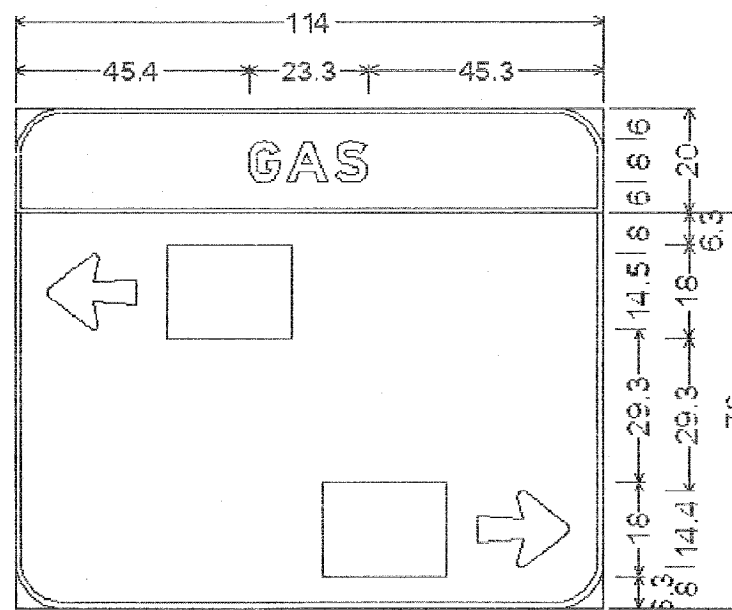

9.0" Radius, 1.0" Border, White on Blue; 6.8
 "GAS" E Mod 2K;
 9.0" Radius, 1.0" Border, White on Blue;
 Untitle1; Untitle1;

Table of widths and spaces.

G	A	S
45.4	6.4	1.1
6.3	17.5	6.0
59.8	24.0	6.0

#16 FSF I-57 RAMP EE

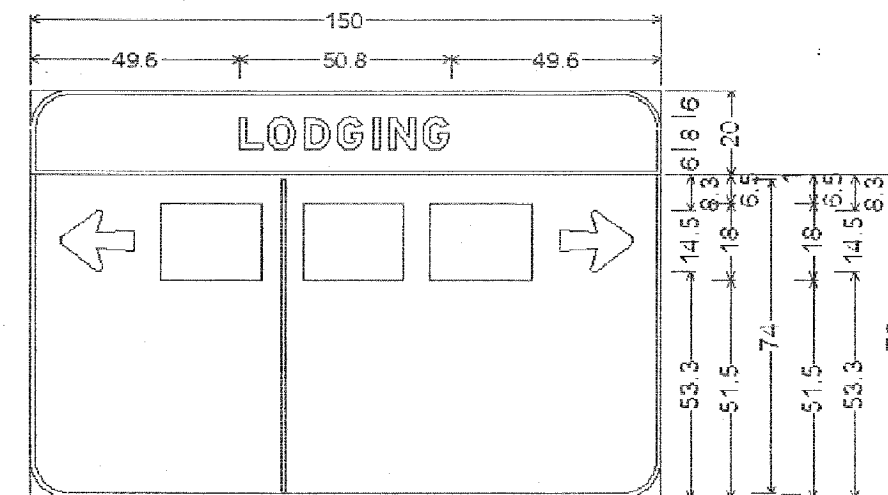

9.0" Radius, 1.0" Border, White on Blue;
 "LODGING" E Mod 2K;
 9.0" Radius, 1.0" Border, White on Blue;
 Untitle1; Untitle1;

Table of widths and spaces.

L	O	D	G	I	N	G
49.6	6.0	0.9	6.8	1.9	6.5	1.5
7.0	17.5	6.5	24.0	4.5	1.0	4.5

PLOT DATE = 10/12/2008
 FILE NAME = c:\p\projects\98950\1013\1013\1013.dwg
 USER NAME = Person

REVISIONS		ILLINOIS DEPARTMENT OF TRANSPORTATION
NAME	DATE	

SIGN PANELS

SCALE: VERT. NO SCALE
 HORIZ. DATE DRAWN BY CHECKED BY

F.A. RTE.	SECTION	COUNTY	TOTAL SHEETS	SHEET NO.
*	**	WILLIAMSON	917	772
STA.		TO STA.		
FED. ROAD DIST. NO.		ILLINOIS FED. AID PROJECT		

* I-57, & OLD IL 13 (FAU 9629)
 ** (X1-6-2)VB-2,(X1-6)HBK-2

FSI #17 RAMP F

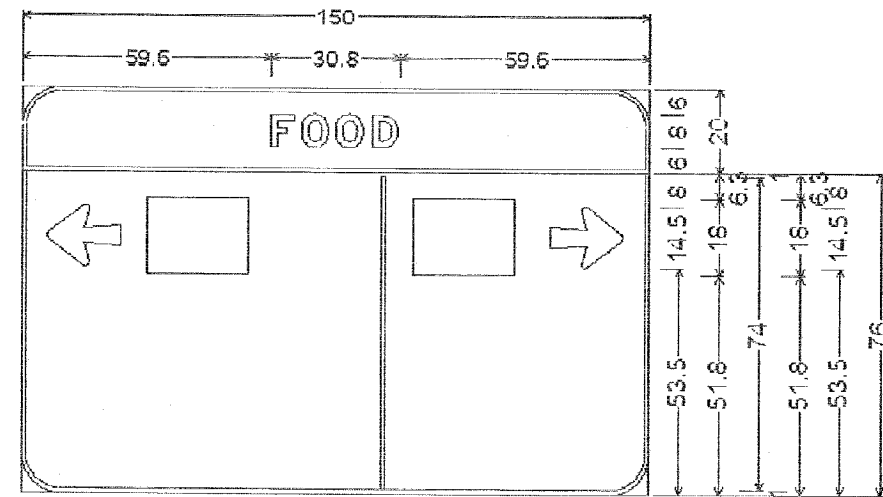

16 17.5 24 32 24 17.5 6.5
 9.0" Radius, 1.0" Border, White on Blue;

"FOOD" E Mod 2K;
 9.0" Radius, 1.0" Border, White on Blue;

Untitled1; Untitled1;

Table of widths and spaces.

59.6	F	6.0	1.4	6.6	1.6	6.8	1.9	6.5	59.6		
6.0	←	17.5	6.5	24.0	32.0	1.0	6.5	24.0	8.5	17.5	6.5

#18 I-57 RAMP EE

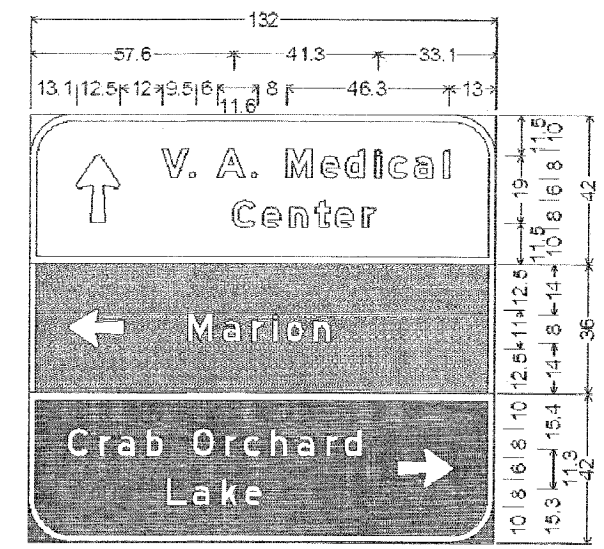

11 16 18 41 46
 11 27.6 8 48.4 10 16 11
 39.1 27.9 65

12.0" Radius, 2.0" Border, White on Blue;

Arrow Custom - 19.0" 90"; "V." E Mod;

"A." E Mod; "Medical" E Mod; "Center" E Mod;

3.0" Radius, 2.0" Border, White on Green;

"Marion" E Mod;

12.0" Radius, 2.0" Border, White on Brown;

"Crab" E Mod; "Orchard" E Mod; "Lake" E Mod;

Table of widths and spaces.

13.1	↑	12.5	V	12.0	7.4	0.5	1.6	6.0	A	8.0	2.0	1.6					
8.0	M	7.4	e	2.8	5.1	1.9	5.3	3.0	i	1.5	2.5	5.1	1.9	5.1	3.1	1.5	13.1
57.6	C	6.4	e	2.1	5.3	2.5	5.1	2.3	t	4.1	1.8	5.1	2.6	4.0	33.1		
11.0	↔	16.0															
18.0	M	7.4	a	2.6	5.3	3.0	3.9	1.9	i	1.5	2.5	5.3	2.5	5.1	16.0		
11.0	C	6.4	r	2.6	4.0	1.1	5.3	3.0	h	5.3							
7.9	O	6.6	r	2.8	3.9	1.3	5.0	2.5	h	5.3	2.4	5.1	3.1	4.0	1.1	5.3	
10.0	↔	16.0	11.0														
39.1	L	6.9	a	1.6	5.1	3.1	5.3	1.6	e	5.3	65.0						

PLOT DATE = 10/12/2006
 PLOT SCALE = 6X6000
 USER NAME = hudson

REVISIONS		ILLINOIS DEPARTMENT OF TRANSPORTATION
NAME	DATE	
		SIGN PANELS

SCALE: VERT. NO SCALE
 HORIZ. DATE
 DRAWN BY
 CHECKED BY

STATE OF ILLINOIS
DEPARTMENT OF TRANSPORTATION

CONTRACT NO. 98950				
F.A.I. RT. NO.	SECTION	COUNTY	TOTAL SHEETS	SHEET NO.
*	**	WILLIAMSON	917	773
STA.		TO STA.		
FED. ROAD DIST. NO.	ILLINOIS	FED. AID PROJECT		
* 1-57, & OLD IL 13 (FAU 9629)				
** (X1-6-2)VB-2, (X1-6)HBK-2				

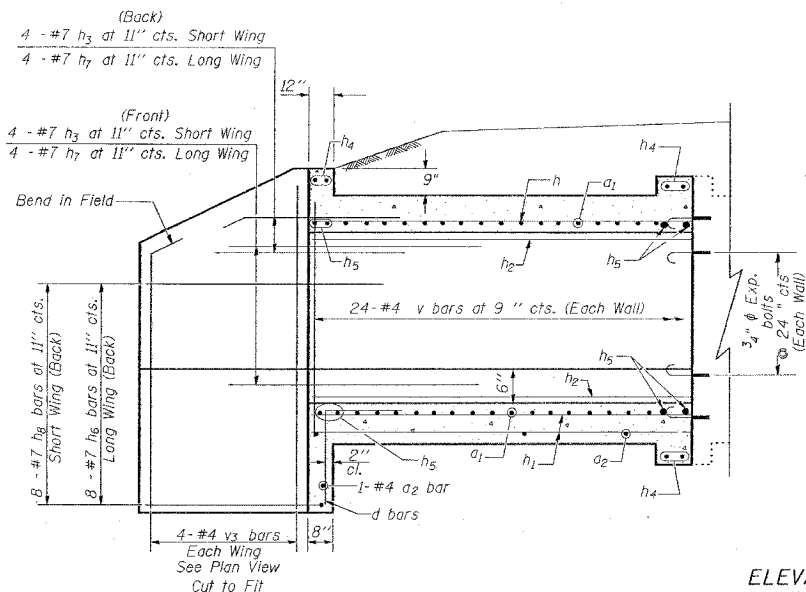

ELEVATION

Dimensions at Rt. L's to R Roadway

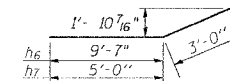
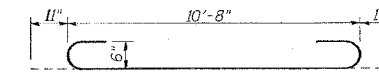
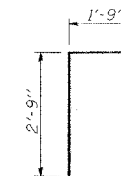
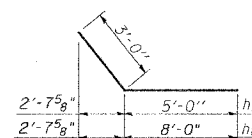
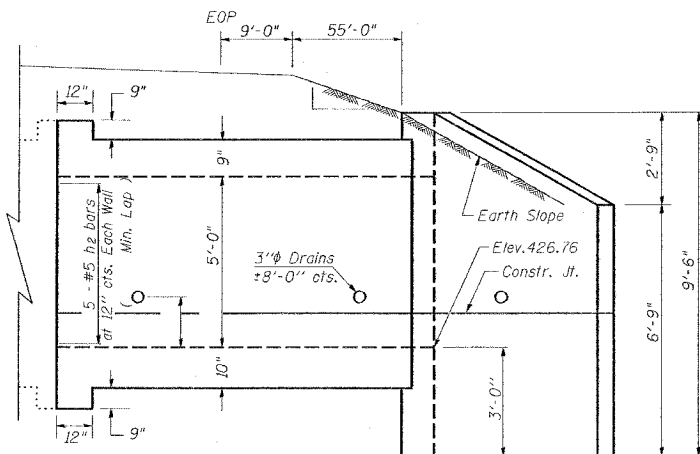

Tilt hook of a₁ bars if necessary for 1 1/2" min. cl.

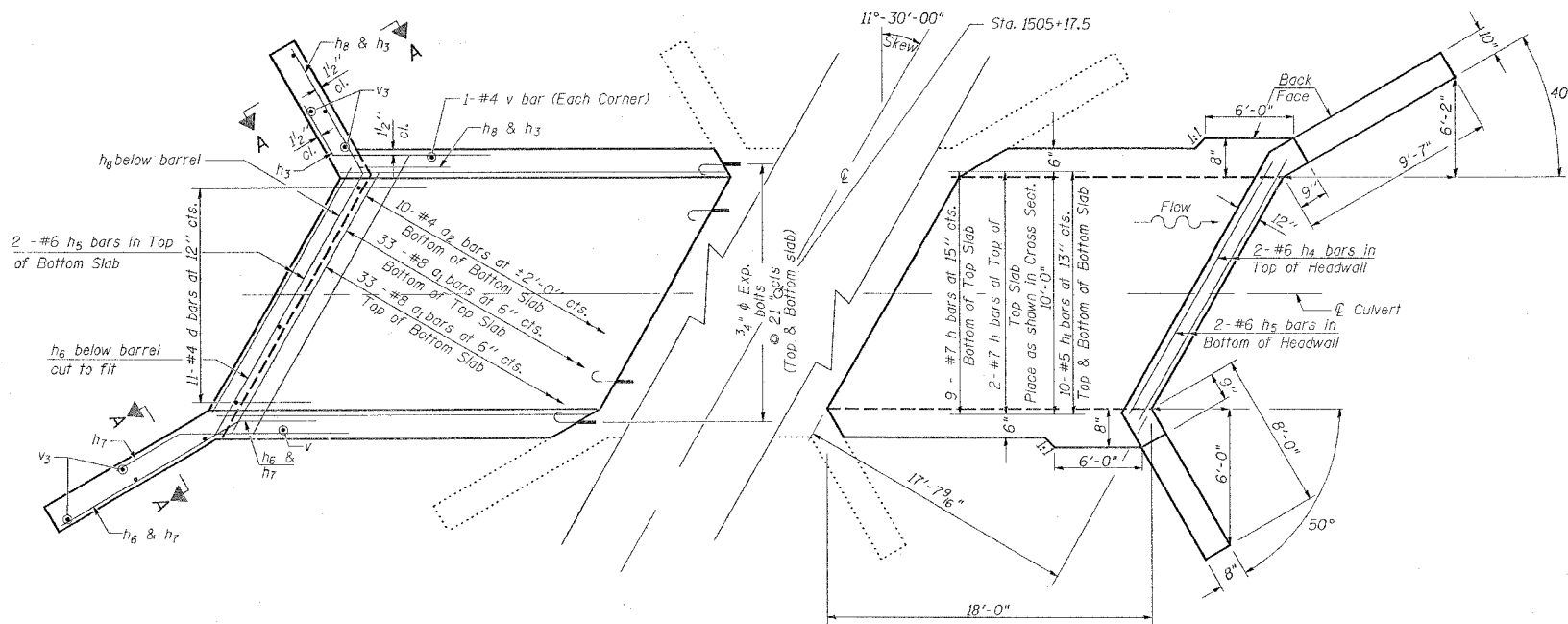
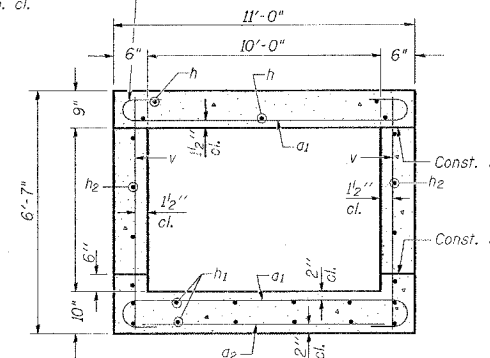

PLAN

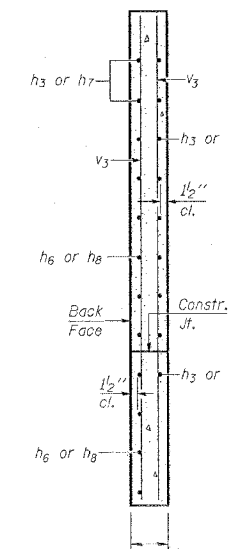

BILL OF MATERIAL

Bar	No.	Size	Length	Shape
a ₁	62	#8	12'-7"	U
a ₂	10	#4	10'-6"	—
d	11	#4	4'-6"	—
h	11	#7	17'-9"	—
h ₁	20	#5	17'-9"	—
h ₂	10	#5	17'-9"	—
h ₃	8	#7	8'-0"	—
h ₄	6	#6	11'-0"	—
h ₅	8	#6	11'-7"	—
h ₆	8	#7	12'-7"	—
h ₇	8	#7	8'-0"	—
h ₈	8	#7	11'-0"	—
v	48	#4	6'-3"	—
v ₁	8	#4	8'-0"	—
Concrete Removal Long Wingwall Cu. Yd. 3.1				
Concrete Removal Short Wingwall Cu. Yd. 2.5				
Concrete Box Culverts Cu. Yd. 21.0				
Reinforcement Bars Pound 4,435				
3/4" Expansion bolts Each 18				

NOTES

Reinforcement Bars shall conform to the requirements of AASHTO M-31, M-42 or M-53, Grade 60.

A distance of half the length of the wingwall but not less than six feet of the barrel shall be poured monolithically with the wingwalls.

All construction joints shall be bonded.

Expansion bolts shall be 3/4" φ x 12" hooked bolts. Hooked bolts shall extend a minimum of 9" into new concrete and have a minimum certified proof load of 4,080 lbs.

No extension to the left. Just shown for reinforcement, Information Only.

DESIGN STRESSES

f_y = 60,000 psi

f'c = 3,500 psi

LOADING HS 20-44 & ALT.

REVISIONS	
NAME	DATE

ILLINOIS DEPARTMENT OF TRANSPORTATION

BOX CULVERT EXTENSION
RT. STATION 1505+17.5 (SB)
10' x 5', SKEW 11°-30'-0" RT. AH.
EXTEND 18'-0"

SCALE: VERT. NO SCALE
HORIZ.

DRAWN BY CNH
CHECKED BY

PLOT DATE: 10/12/2006
FILE NAME: c:\p\proj\2005\98950\2882\old\3\old\3a.dgn
PLOT SCALE: 1/8"=1'-0"
USER NAME: f_hedden

REVISIONS	
DRAWN	2-04
REVISED	
REVISED	
REVISED	

BASED ON: SSB-H-R 6-1-2000

F.A. RTE.	SECTION	COUNTY	TOTAL SHEETS	SHEET NO.
*	**	WILLIAMSON	917	774

STA.	TO STA.

FED. ROAD DIST. NO. ILLINOIS FED. AID PROJECT
 * I-57, & OLD IL 13 (FAU 9629)
 * * (X1-6-2)VB-2,(X1-6)HBK-2

TEMPORARY SIGNS

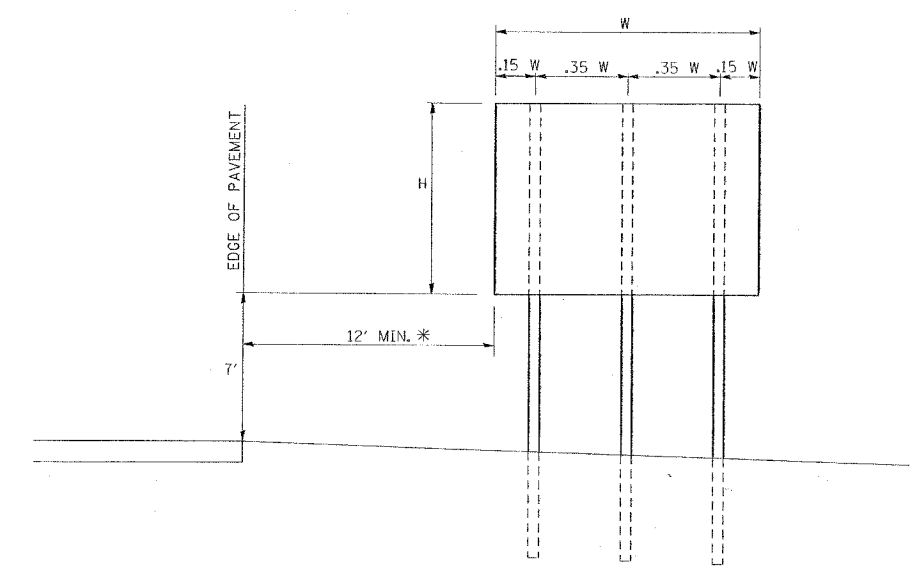

* IF SHOULDER IS WIDER THAN 6', THEN MIN. LATERAL OFFSET SHALL BE 6' FROM EDGE OF SHOULDER.

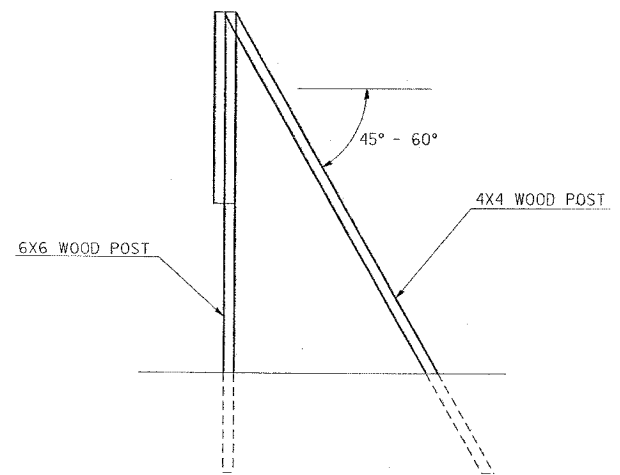

USE A 4X4 SUPPORT POST ON EVERY 6X6 VERTICAL SIGN POST.

STATION	HEIGHT	WIDTH	DESCRIPTION
1522+00	12'-0"	14'-6"	IL 13 WEST CARBONDALE 3/4
1523+00	17'-6"	11'-6"	IL 13 EAST MARION HARRISBURG 1/2
1527+00	9'-0"	12'-6"	MAIN ST. MARION

DETAIL: REMOVAL OF EXISTING STRUCTURES NO. 5
DETAIL: REMOVAL OF EXISTING STRUCTURES NO. 6

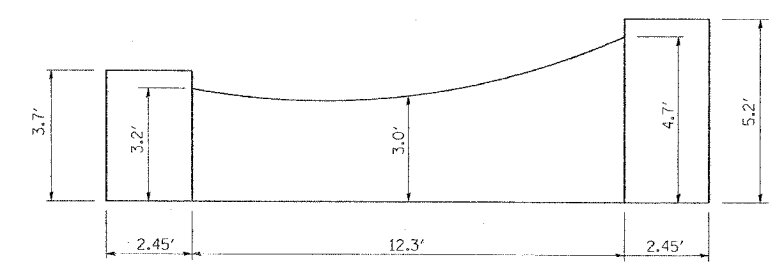

FRONT VIEW

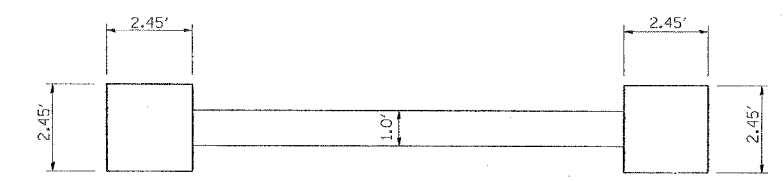

TOP VIEW

THE EXISTING STRUCTURES ARE LOCATED RT. STA. 762+56 AND RT. STA. 763+03 ON EACH SIDE OF THE EXISTING CRISP DRIVE. THE OUTSIDE OF THE STRUCTURES IS BRICK. IT IS UNKNOWN IF THE CORE IS SOLID OR HOLLOW. THE SIZE AND DEPTH OF THE FOUNDATION IS ALSO UNKNOWN.

THE STRUCTURES SHALL BE COMPLETELY REMOVED, WHICH WORK SHALL INCLUDE ALL ATTACHMENTS SUCH AS LIGHTING AND CONDUIT, FOUNDATIONS, AND ANY CORE MATERIAL. THE WORK TO REMOVE THE STRUCTURE RT. STA. 762+56 WILL BE PAID FOR AT THE CONTRACT UNIT PRICE PER EACH FOR REMOVAL OF EXISTING STRUCTURES NO. 5. THE WORK TO REMOVE THE STRUCTURE RT. STA. 763+03 WILL BE PAID AT THE CONTRACT UNIT PRICE PER EACH FOR REMOVAL OF EXISTING STRUCTURES NO. 6.

REVISIONS	
NAME	DATE

ILLINOIS DEPARTMENT OF TRANSPORTATION
DETAILS:
TEMPORARY SIGNS; REMOVAL OF EXISTING STRUCTURES NO. 5 AND NO. 6
 SCALE: VERT. NONE
 HORIZ.
 DATE
 DRAWN BY CNH
 CHECKED BY

F.A. RTE.	SECTION	COUNTY	TOTAL SHEETS	SHEET NO.
*	**	WILLIAMSON	917	775
STA.	TO STA.			
FED. ROAD DIST. NO.	ILLINOIS FED. AID PROJECT			

* I-57, & OLD IL 13 (FAU 9629)
 ** (X1-6-2)VB-2,(X1-6)HBK-2

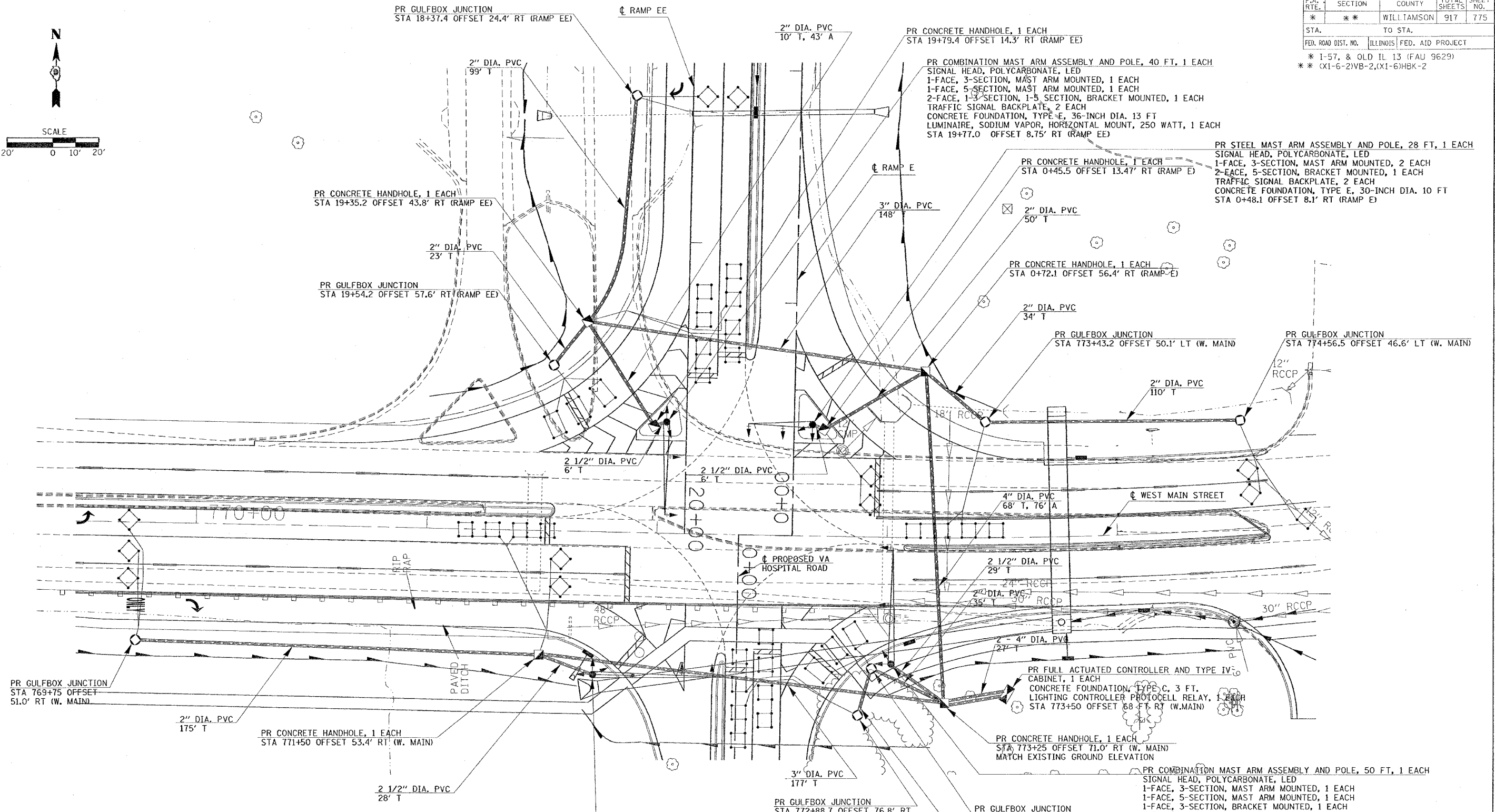
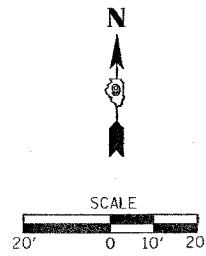

- NOTE:**
1. CONDUIT PAID FOR AS TRENCHED MAY, AT THE CONTRACTOR'S OPTION, BE AUGERED. THE CONDUIT WILL BE PAID FOR AT THE TRENCHED UNIT PRICE.
 2. FOR INTERSECTION LIGHTING SEE DETAIL SHEET

PR STEEL COMBINATION MAST ARM ASSEMBLY AND POLE, 55 FT, 1 EACH
 SIGNAL HEAD, POLYCARBONATE, LED
 1-FACE, 3-SECTION, MAST ARM MOUNTED, 2 EACH
 1-FACE, 3-SECTION, BRACKET MOUNTED, 1 EACH
 2-FACE, 5-SECTION, BRACKET MOUNTED, 1 EACH
 TRAFFIC SIGNAL BACKPLATE, 2 EACH
 CONCRETE FOUNDATION, TYPE E, 36-INCH DIA. 15 FT
 LUMINAIRE, SODIUM VAPOR, HORIZONTAL MOUNT, 250 WATT, 1 EACH
 STA 771+73.5 OFFSET 61.5' RT (W. MAIN)

REVISIONS	
NAME	DATE

ILLINOIS DEPARTMENT OF TRANSPORTATION

**TRAFFIC SIGNALS
 INTERSECTION OF RAMP E&E
 AND OLD IL 13**

SCALE: VERT. 20
 HORIZ. 20
 DATE

DRAWN BY MB
 CHECKED BY

PLOT DATE = 10/19/2006
 PLOT SCALE = 20/2000 = 1/100
 USER NAME = hudson

F.A. RTE.	SECTION	COUNTY	TOTAL SHEETS	SHEET NO.
*	**	WILLIAMSON	917	776

STA. TO STA.
 FED. ROAD DIST. NO. ILLINOIS FED. AID PROJECT
 * I-57, & OLD IL 13 (FAU 9629)
 ** (X1-6-2)VB-2,(X1-6)HKB-2

NOTES:

1. ALL SIGNAL LENSES SHALL BE 12 INCHES.
2. ELECTRIC CABLE DENOTED AS #10, 3/C BEING INSTALLED TO THE COMBINATION MAST ARM POLES SHALL NOT GO THROUGH THE TERMINAL BLOCK BUT SHOULD BE SPLICED IN POLE. SEE LIGHT POLE FOUNDATION DETAIL.
3. ALL CABLES SHALL BE A.W.G. #14 UNLESS OTHERWISE NOTED.
4. ALL LUMINAIRES ARE 250 WATT.
5. THE SIGNAL CONDUIT SYSTEM SHALL BE UTILIZED TO INSTALL WIRING FOR THE PROPOSED LIGHTING SYSTEM WHERE CONDUIT IS REQUIRED.
6. ELECTRIC CABLE IN CONDUIT NO 10 SHALL BE USED IN POLES AND LUMINAIRES.
7. ELECTRIC SERVICE SUPPLIED BY CITY OF MARION FROM DECORATIVE ROCK LOCATED IN SE QUAD. OF THE INTERSECTION.

WIRING DIAGRAM FOR ROADWAY LIGHTING

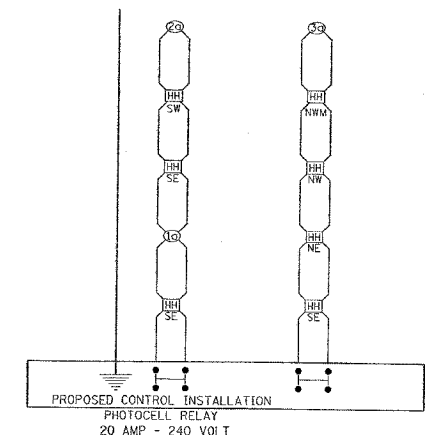

LEGEND

- ⊞ INDICATES PROPOSED TRAFFIC SIGNAL HANDHOLE
- HANDHOLE DESIGNATIONS:
 NE NORTHEAST CORNER
 NW NORTHWEST CORNER
 SE SOUTHEAST CORNER
 SW SOUTHWEST CORNER
 NWM NORTHWEST MEDIAN
- ⊙ INDICATES POSITION OF TRAFFIC SIGNAL POST IN WIRING DIAGRAM WITH LUMINAIRE
- ⊞ INDICATES CONTINUOUS GROUND FOR CONTROL INSTALLATION.

LEGEND

- T INDICATES TERMINAL BLOCK ON MAST ARM POLE (SEE SPECIAL PROVISIONS)
- INDICATES 6' X 6' DETECTOR LOOP WITH 2" CORE DRILLED CORNERS.
- ◇ INDICATES 5' X 5' DETECTOR LOOP WITH 2" CORE DRILLED CORNERS. THESE LOOPS REQUIRE AMPLIFIERS WITH SYSTEM OUTPUT
- ▭ INDICATES 6' X 14' DETECTOR LOOP WITH 2" CORE DRILLED CORNERS.
- ⊞ 12" TRAFFIC SIGNAL SECTION
- ⊞ TRAFFIC SIGNAL CONTROLLER CABINET
- ⊞ LIGHTING CONTROLLER WITH PHOTOCELL RELAY
- ⊞ 5' X 5' ADVANCE LOOP WITH 2" CORE DRILLED CORNERS; NUMBER INDICATES PHASE, LOWER CASE LETTER INDICATES AMPLIFIER, "S" INDICATES SYSTEM
- ⊙ INDICATES 2/C TWISTED, SHIELDED CABLE IN CONDUIT
- ⊙ NUMBER IN CIRCLE INDICATES NUMBER OF CONDUCTORS IN THAT CABLE
- (3) NUMBER IN PARENTHESIS INDICATES PHASE
- 1a NUMBER INDICATES PHASE; LETTER OR LETTERS IDENTIFY AMPLIFIER
- ⊞ LUMINAIRE

REVISIONS	
NAME	DATE

ILLINOIS DEPARTMENT OF TRANSPORTATION
**WIRING DIAGRAM FOR
 INTERSECTION RAMP E/E
 AND OLD IL 13**

SCALE: VERT. NONE
 HORIZ. DATE DRAWN BY MB
 CHECKED BY

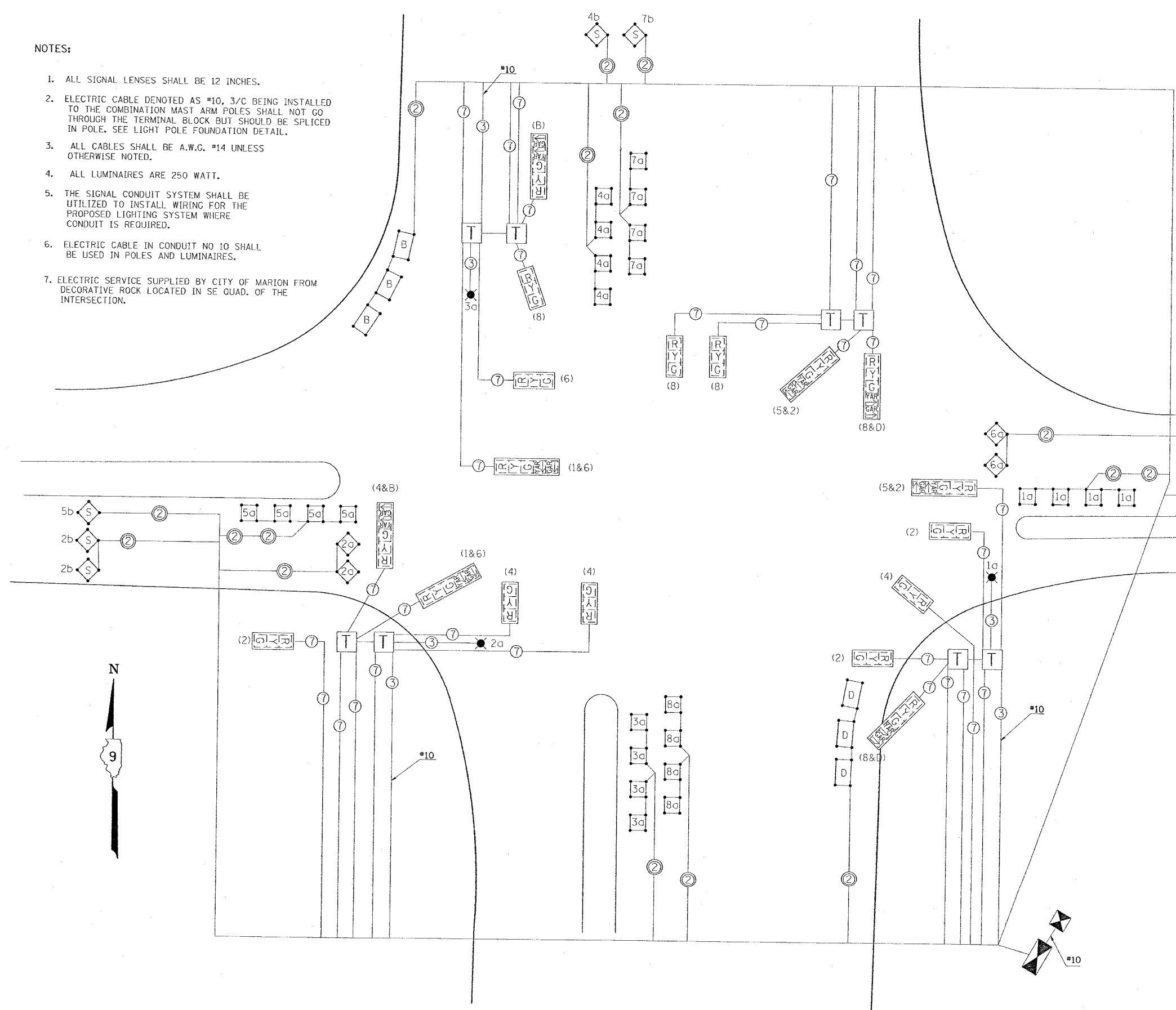

PLOT DATE = 10/15/2006
 FILE NAME = I:\98282\1013\1013_15.dgn
 PLOT SCALE = 50.0000 / 1"
 USER NAME = hudson

F.A. RTE.	SECTION	COUNTY	TOTAL SHEETS	SHEET NO.
*	*	WILLIAMSON	917	777

STA. TO STA.
 FED. ROAD DIST. NO. ILLINOIS FED. AID PROJECT
 * I-57, & OLD IL 13 (FAU 9629)
 ** (X1-6-2)VB-2,(X1-6)HBK-2



9

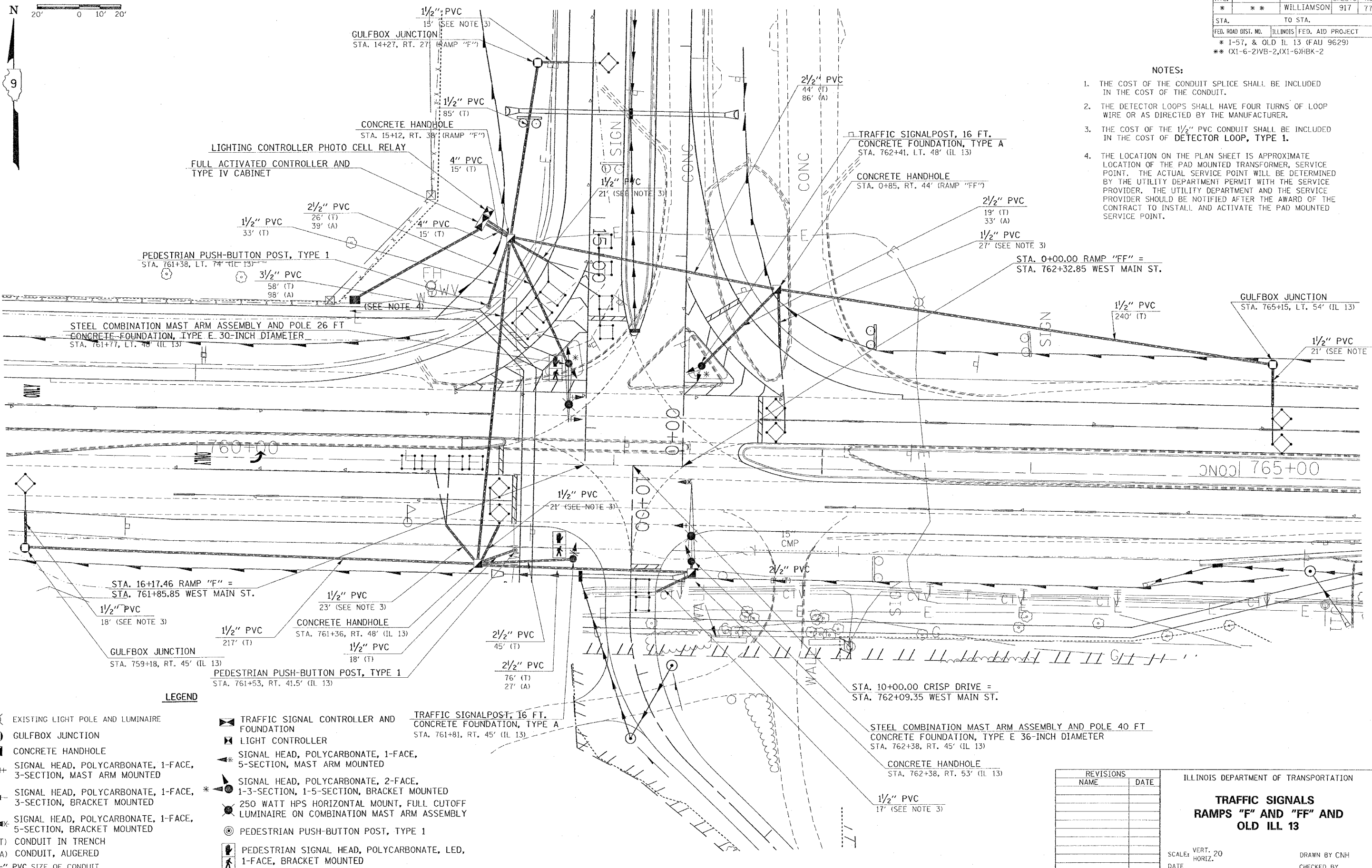

- NOTES:**
1. THE COST OF THE CONDUIT SPLICE SHALL BE INCLUDED IN THE COST OF THE CONDUIT.
 2. THE DETECTOR LOOPS SHALL HAVE FOUR TURNS OF LOOP WIRE OR AS DIRECTED BY THE MANUFACTURER.
 3. THE COST OF THE 1/2" PVC CONDUIT SHALL BE INCLUDED IN THE COST OF DETECTOR LOOP, TYPE 1.
 4. THE LOCATION ON THE PLAN SHEET IS APPROXIMATE LOCATION OF THE PAD MOUNTED TRANSFORMER, SERVICE POINT. THE ACTUAL SERVICE POINT WILL BE DETERMINED BY THE UTILITY DEPARTMENT PERMIT WITH THE SERVICE PROVIDER. THE UTILITY DEPARTMENT AND THE SERVICE PROVIDER SHOULD BE NOTIFIED AFTER THE AWARD OF THE CONTRACT TO INSTALL AND ACTIVATE THE PAD MOUNTED SERVICE POINT.

LEGEND

- ⊗ EXISTING LIGHT POLE AND LUMINAIRE
- ⊙ GULFBOX JUNCTION
- ⊠ CONCRETE HANDHOLE
- ⊕ SIGNAL HEAD, POLYCARBONATE, 1-FACE, 3-SECTION, MAST ARM MOUNTED
- ⊖ SIGNAL HEAD, POLYCARBONATE, 1-FACE, 3-SECTION, BRACKET MOUNTED
- ⊗ SIGNAL HEAD, POLYCARBONATE, 1-FACE, 5-SECTION, BRACKET MOUNTED
- (T) CONDUIT IN TRENCH
- (A) CONDUIT, AUGERED
- PVC SIZE OF CONDUIT
- ⊠ TRAFFIC SIGNAL CONTROLLER AND FOUNDATION
- ⊠ LIGHT CONTROLLER
- ⊕ SIGNAL HEAD, POLYCARBONATE, 1-FACE, 5-SECTION, MAST ARM MOUNTED
- ⊖ SIGNAL HEAD, POLYCARBONATE, 2-FACE, 1-3-SECTION, 1-5-SECTION, BRACKET MOUNTED
- ⊗ 250 WATT HPS HORIZONTAL MOUNT, FULL CUTOFF LUMINAIRE ON COMBINATION MAST ARM ASSEMBLY
- ⊙ PEDESTRIAN PUSH-BUTTON POST, TYPE 1
- ⊠ PEDESTRIAN SIGNAL HEAD, POLYCARBONATE, LED, 1-FACE, BRACKET MOUNTED

REVISIONS	
NAME	DATE

ILLINOIS DEPARTMENT OF TRANSPORTATION

**TRAFFIC SIGNALS
 RAMPS "F" AND "FF" AND
 OLD ILL 13**

SCALE: VERT. 20
 HORIZ. 1" = 40'

DATE: _____ DRAWN BY CNH
 CHECKED BY _____

PLOT DATE = 10/13/2006
 FILE NAME = c:\p\projects\98950\98950.dwg
 PLOT SCALE = 24.0000 / IN.
 USER NAME = hudson

F.A. RTE.	SECTION	COUNTY	TOTAL SHEETS	SHEET NO.
*	**	WILLIAMSON	917	778

STA. TO STA.
 FED. ROAD DIST. NO. ILLINOIS FED. AID PROJECT
 *I-57, & OLD IL 13 (FAU 9629)
 ** (X1-6-2)VB-2, (X1-6)HBK-2

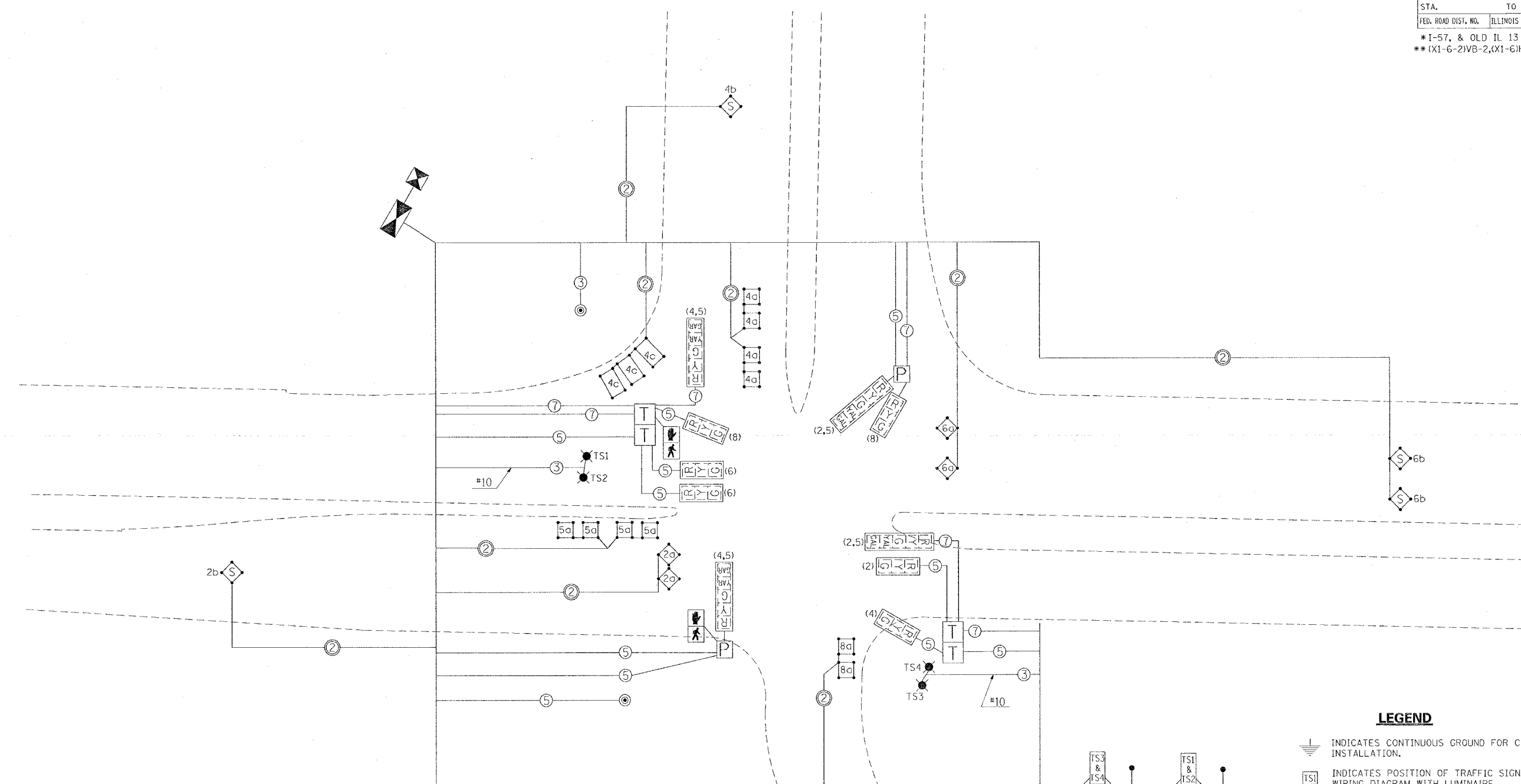

LEGEND

- INDICATES TERMINAL BLOCK ON MAST ARM POLE (SEE SPECIAL PROVISIONS)
- INDICATES TRAFFIC SIGNAL POST
- INDICATES 6' X 6' DETECTOR LOOP WITH 2" CORE DRILLED CORNERS.
- INDICATES 5' X 5' DETECTOR LOOP WITH 2" CORE DRILLED CORNERS. THESE LOOPS REQUIRE AMPLIFIERS WITH SYSTEM OUTPUT
- INDICATES 6' X 14' DETECTOR LOOP WITH 2" CORE DRILLED CORNERS.
- 12" TRAFFIC SIGNAL SECTION
- TRAFFIC SIGNAL CONTROLLER CABINET
- LIGHTING CONTROLLER WITH PHOTOCELL RELAY
- INDICATES 5' X 5' ADVANCE LOOP WITH 2" CORE DRILLED CORNERS; NUMBER INDICATES PHASE, LOWER CASE LETTER INDICATES AMPLIFIER, "S" INDICATES SYSTEM
- INDICATES 2/C TWISTED, SHIELDED CABLE IN CONDUIT NUMBER IN CIRCLE INDICATES NUMBER OF CONDUCTORS IN THAT CABLE
- NUMBER IN PARENTHESIS INDICATES PHASE
- NUMBER INDICATES PHASE; LETTER OR LETTERS IDENTIFY AMPLIFIER
- LUMINAIRE
- PEDESTRIAN SIGNAL HEAD
- PEDESTRIAN PUSH-BUTTON POST

NOTES:

1. ALL SIGNAL LENSES SHALL BE 12 INCHES.
2. ELECTRIC CABLE DENOTED AS #10, 3/C BEING INSTALLED TO THE COMBINATION MAST ARM POLES SHALL NOT GO THROUGH THE TERMINAL BLOCK BUT SHOULD BE SPLICED IN POLE. SEE LIGHT POLE FOUNDATION DETAIL.

NOTE: ALL CABLES SHALL BE A.W.G. #14 UNLESS OTHERWISE NOTED

LEGEND

- INDICATES CONTINUOUS GROUND FOR CONTROL INSTALLATION.
- INDICATES POSITION OF TRAFFIC SIGNAL POST IN WIRING DIAGRAM WITH LUMINAIRE

NOTES:

1. ALL LUMINAIRES ARE 250 WATT.
2. THE SIGNAL CONDUIT SYSTEM SHALL BE UTILIZED TO INSTALL WIRING FOR THE PROPOSED LIGHTING SYSTEM WHERE CONDUIT IS REQUIRED.

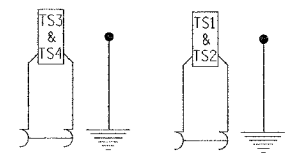

LIGHTING CONTROLLER
 PHOTOCELL RELAY
 20 AMP - 240 VOLT

REVISIONS	
NAME	DATE

ILLINOIS DEPARTMENT OF TRANSPORTATION

**WIRING DIAGRAM FOR
 OLD IL 13 RAMP F & FF**

SCALE: VERT. NONE
 HORIZ.

DRAWN BY CNH
 CHECKED BY

PLOT DATE = 10/19/2005
 FILE NAME = c:\p10\mex\980202\old13\old13p4.dgn
 PLOT SCALE = 5/8,3000 / IN.
 USER NAME = haddon

F.A. RTE.	SECTION	COUNTY	TOTAL SHEETS	SHEET NO.
*	**	WILLIAMSON	917	779
STA.		TO STA.		
FED. ROAD DIST. NO.		ILLINOIS FED. AID PROJECT		
* I-57, & OLD IL 13 (FAU 9629)				
* (X1-6-2)VB-2,(X1-6)HBK-2				



LIGHTING SYMBOL LEGEND

- LIGHTING CONTROLLER
- JUNCTION BOX, STAINLESS STEEL
- LUMINAIRE, 400 WATT HPS, 50 FT. MOUNTING HEIGHT. LUMINAIRES ON BRIDGE SHALL HAVE 3 FT. DAVIT ARM, ALL OTHERS SHALL HAVE 15 FT. DAVIT ARM
- LUMINAIRE, 250 WATT HPS, 45 FT. MOUNTING HEIGHT, 15 FT. DAVIT ARM
- CONDUIT PUSHED, INTERMEDIATE METAL
- CABLE IN UNIT DUCT. SEE WIRING DIAGRAMS FOR SIZES
- UNDERPASS LIGHTING UNIT. ALL CONDUIT AND WIRE TO UNDERPASS LIGHTING UNITS SHALL BE INCLUDED WITH THE UNDERPASS LIGHTING UNITS AND SHALL BE PAID FOR AT THE CONTRACT UNIT PRICE EACH FOR "UNDERPASS LIGHTING UNIT, 150 WATT HPS". NO ADDITIONAL COMPENSATION WILL BE ALLOWED.

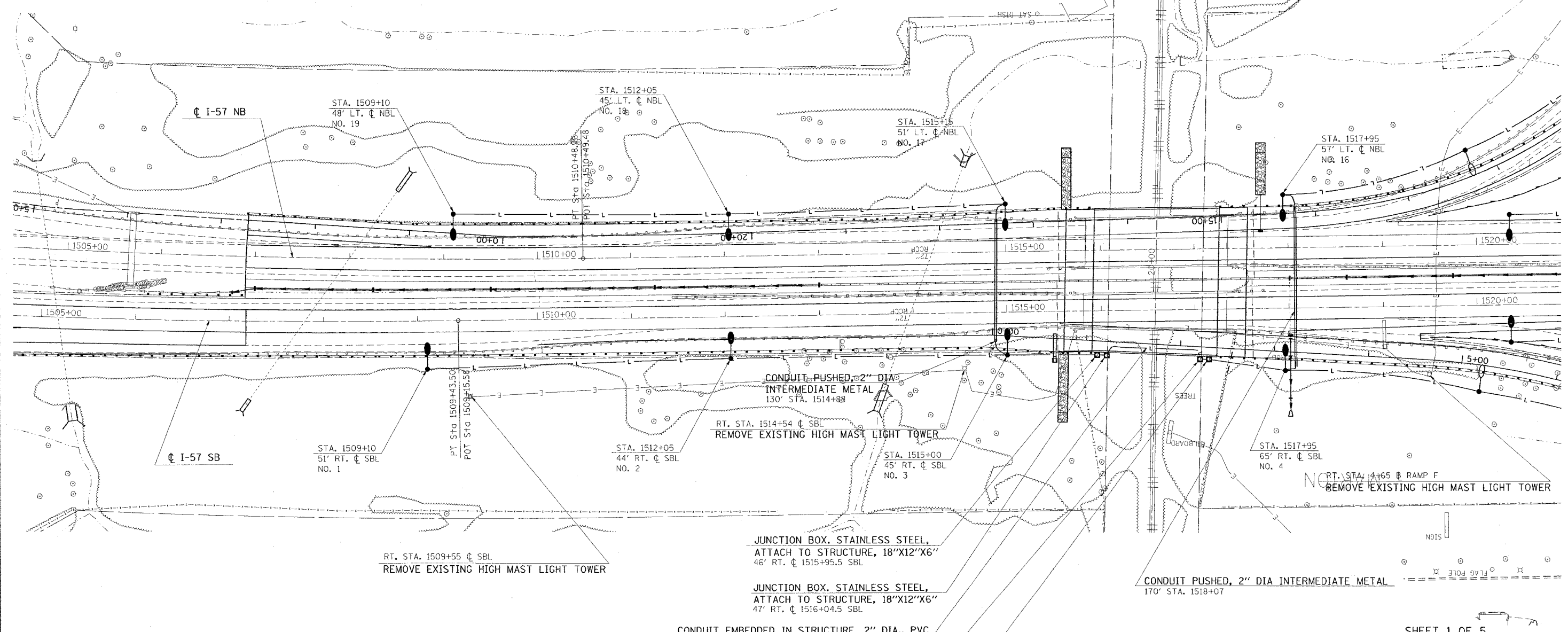

RT. STA. 1509+55 @ SBL
REMOVE EXISTING HIGH MAST LIGHT TOWER

JUNCTION BOX, STAINLESS STEEL,
ATTACH TO STRUCTURE, 18"X12"X6"
46' RT. @ 1515+95.5 SBL

JUNCTION BOX, STAINLESS STEEL,
ATTACH TO STRUCTURE, 18"X12"X6"
47' RT. @ 1516+04.5 SBL

CONDUIT EMBEDDED IN STRUCTURE, 2" DIA., PVC

JUNCTION BOX, STAINLESS STEEL,
ATTACH TO STRUCTURE, 18"X12"X6"
52' RT. @ 1517+04.5 SBL

JUNCTION BOX, STAINLESS STEEL,
ATTACH TO STRUCTURE, 18"X12"X6"
53.5' RT. @ 1517+14 SBL

CONDUIT PUSHED, 2" DIA INTERMEDIATE METAL
170' STA. 1518+07

RT. STA. 1517+65 @ RAMP F
REMOVE EXISTING HIGH MAST LIGHT TOWER

REVISIONS	
NAME	DATE

ILLINOIS DEPARTMENT OF TRANSPORTATION

LIGHTING
I-57
STA. 1505+00 TO STA. 1520+00

SCALE: VERT. 50
DATE
DRAWN BY CNH
CHECKED BY LA

PLOT DATE = 11/28/2008
FILE NAME = c:\p\projects\982922\1513\1513.dgn
PLOT SCALE = 50.0000 / IN.
USER NAME = leedon

F.A. RTE.	SECTION	COUNTY	TOTAL SHEETS	SHEET NO.
*	**	WILLIAMSON	917	780
STA. TO STA.				
FED. ROAD DIST. NO. ILLINOIS FED. AID PROJECT				
* I-57, & OLD IL 13 (FAU 9629)				
** (X1-6-2)VB-2,(X1-6)HBK-2				

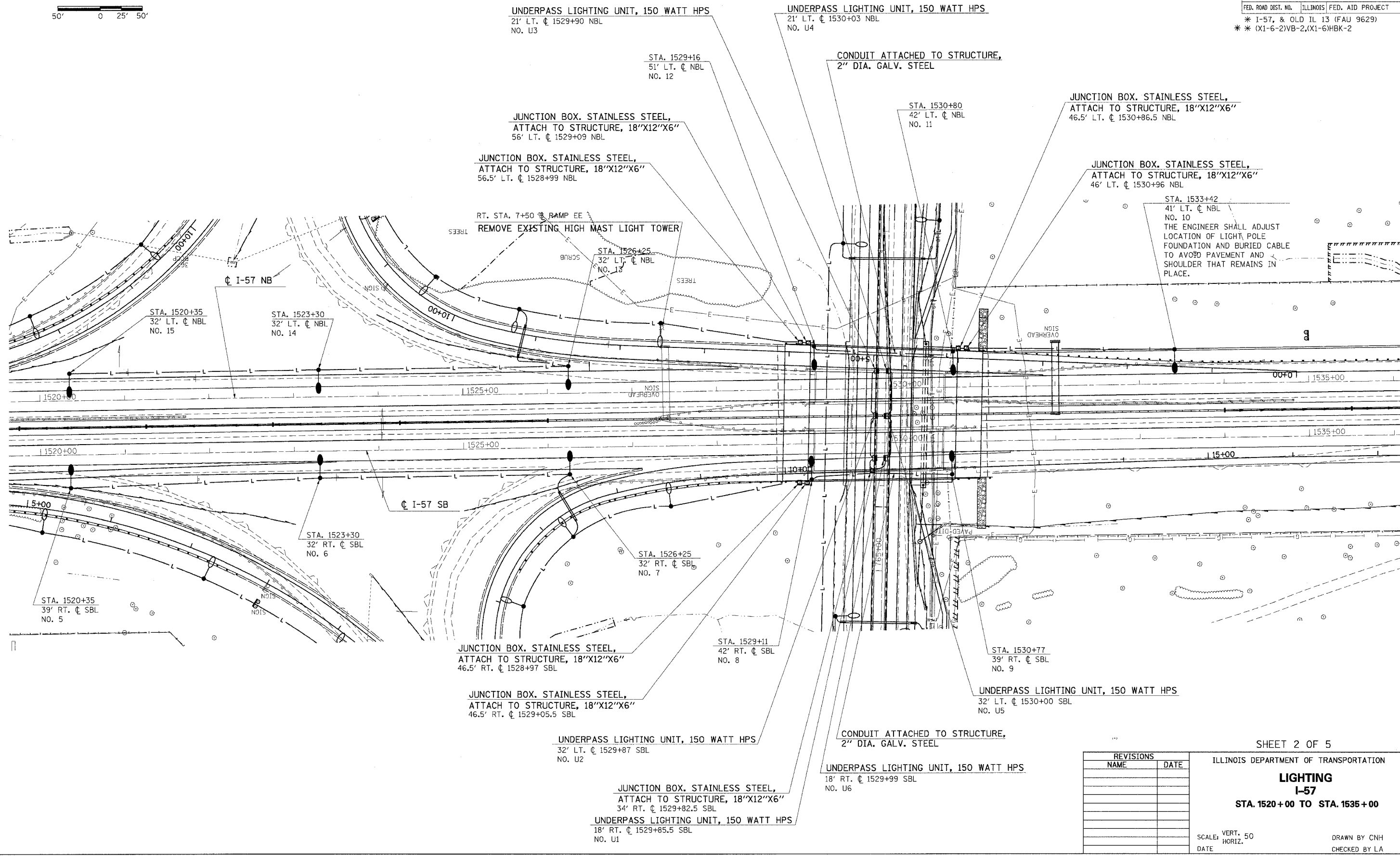

PLOT DATE = 12/7/2006
 FILE NAME = c:\p\c\m\m\13\22802\ad13\ad13p12.dgn
 PLOT SCALE = 50.0000 / 1" = 50'
 USER NAME = hudson

SHEET 2 OF 5

REVISIONS	
NAME	DATE

ILLINOIS DEPARTMENT OF TRANSPORTATION
LIGHTING
I-57
STA. 1520+00 TO STA. 1535+00

SCALE: VERT. 50
 HORIZ. 1" = 50'
 DATE
 DRAWN BY CNH
 CHECKED BY LA

F.A. RTE.	SECTION	COUNTY	TOTAL SHEETS	SHEET NO.
*	**	WILLIAMSON	917	781
STA.	TO STA.			
FED. ROAD DIST. NO.	ILLINOIS FED. AID PROJECT			
* I-57, & OLD IL 13 (FAU 9629)				
** (X1-6-2)VB-2,(X1-6)HBK-2				

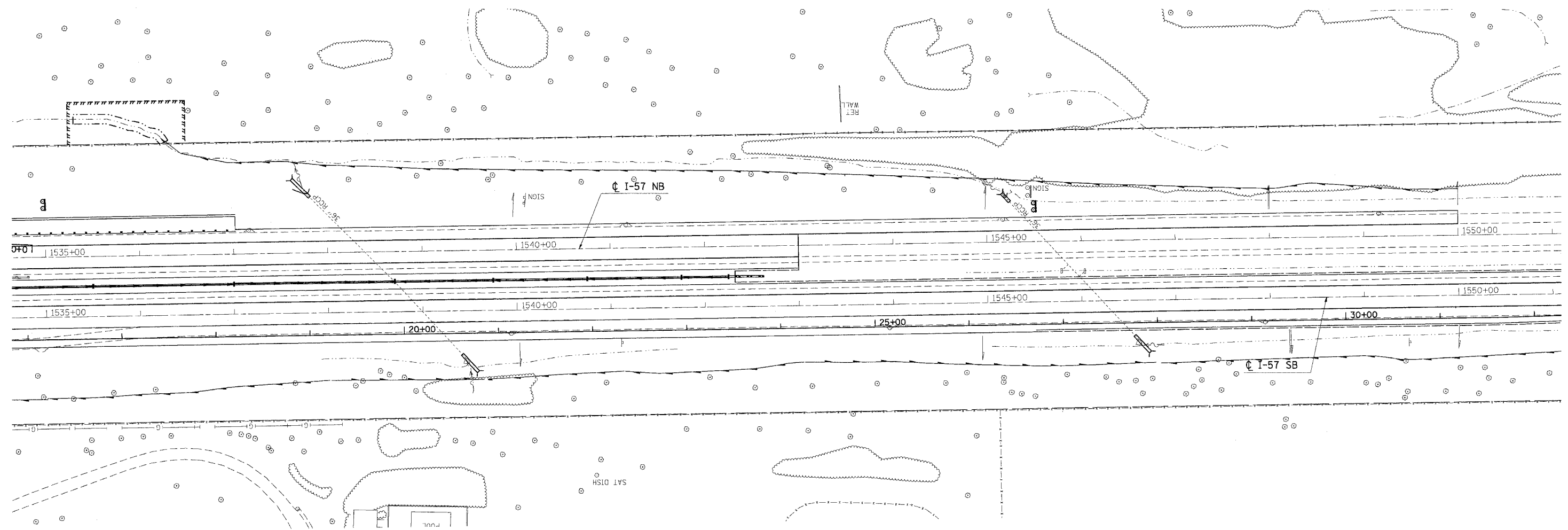

PLOT DATE = 12/7/2006
 FILE NAME = c:\p\projects\982982\old\1541\p12.dgn
 USER NAME = hnsch

REVISIONS	
NAME	DATE

SHEET 3 OF 5
 ILLINOIS DEPARTMENT OF TRANSPORTATION
LIGHTING
I-57
STA. 1535+00 TO STA. 1550+00
 SCALE: VERT. 50
 HORIZ. DATE
 DRAWN BY CNH
 CHECKED BY LA

F.A. RTE.	SECTION	COUNTY	TOTAL SHEETS	SHEET NO.
*	**	WILLIAMSON	917	782
STA.		TO STA.		
FED. ROAD DIST. NO.		ILLINOIS FED. AID PROJECT		

* I-57, & OLD IL 13 (FAU 9629)
 ** (X1-6-2)VB-2,(X1-6)HBK-2

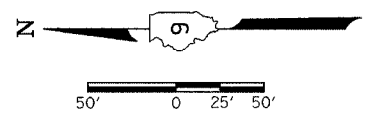
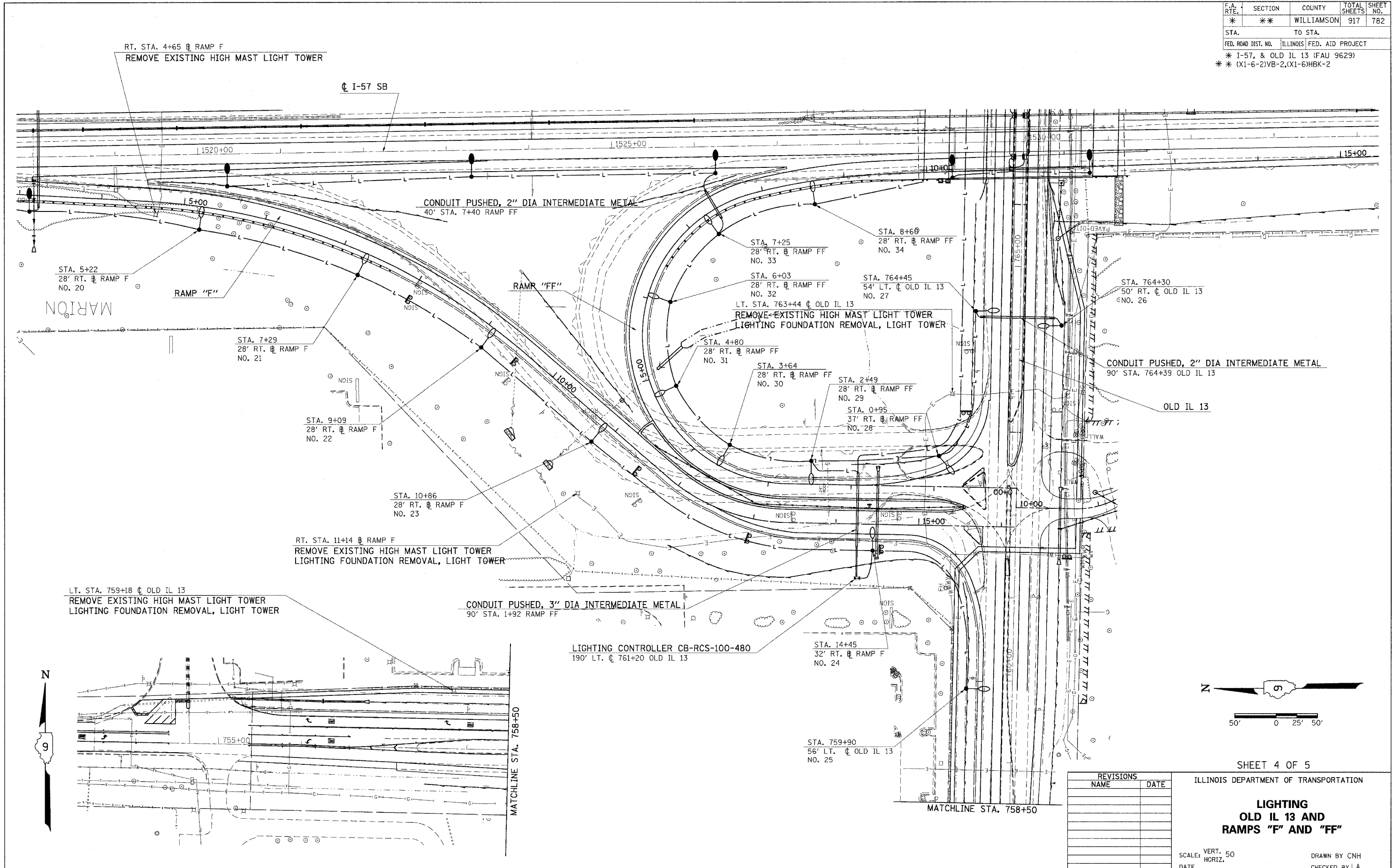

PLOT DATE = 12/7/2005
 FILE NAME = c:\p\projects\98950\old\13\old\sp12.dgn
 PLOT NO. = 1
 USER NAME = hnsdr

REVISIONS	NAME	DATE

SHEET 4 OF 5
 ILLINOIS DEPARTMENT OF TRANSPORTATION
**LIGHTING
 OLD IL 13 AND
 RAMPS "F" AND "FF"**
 SCALE: VERT. 50
 HORIZ. DATE
 DRAWN BY CNH
 CHECKED BY LA

CONTRACT NO. 98950			
F.A. RTE.	SECTION	COUNTY	TOTAL SHEETS NO.
*	**	WILLIAMSON	917 783
STA.	TO STA.		
FED. ROAD DIST. NO.	ILLINOIS FED. AID PROJECT		
* I-57, & OLD IL 13 (FAU 9629)			
* (X1-6-2)VB-2,(X1-6)HBK-2			

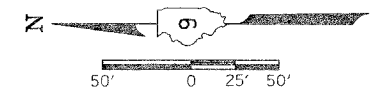
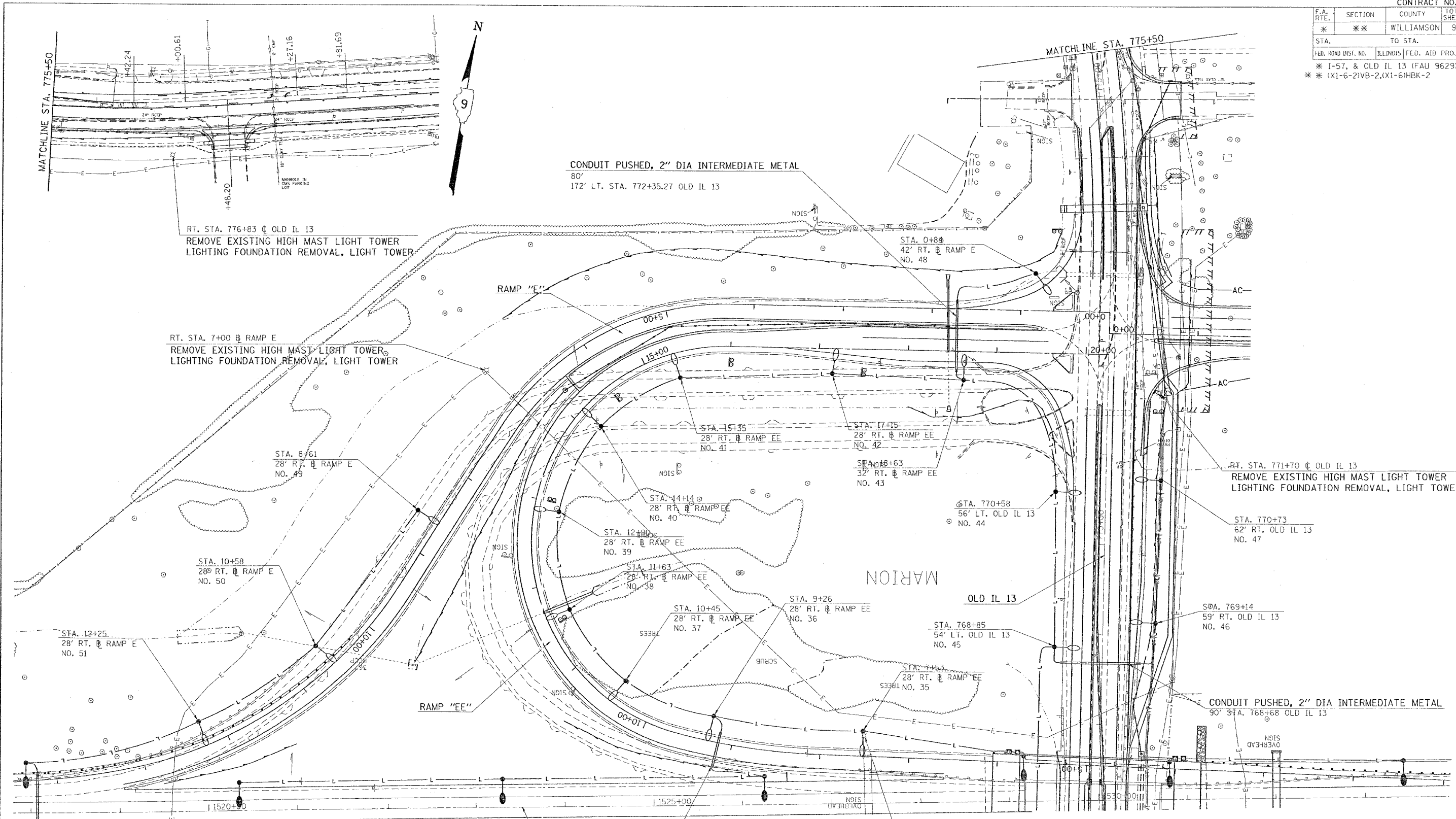

PLOT DATE = 10/13/2006
 FILE NAME = c:\pwworkspace\1013\oldil13\oldil13.dgn
 PLOT SCALE = 50.0000' / 1" IN.
 USER NAME = hudson

REVISIONS	
NAME	DATE

SHEET 5 OF 5

ILLINOIS DEPARTMENT OF TRANSPORTATION

**LIGHTING
OLD IL 13 AND
RAMPS "E" AND "EE"**

SCALE: VERT. 50
DATE _____

DRAWN BY CNH
CHECKED BY L.A.

F.A. RTE.	SECTION	COUNTY	TOTAL SHEETS	SHEET NO.
*	**	WILLIAMSON	917	785
STA.		TO STA.		
FED. ROAD DIST. NO.		ILLINOIS FED. AID PROJECT		

* I-57, & OLD IL 13 (FAU 9629)
 ** (X1-6-2)VB-2,(X1-6)HBK-2

LIGHT POLE MOUNTING HEIGHT	BOLT CIRCLE DIAMETER	STEEL FOUNDATION			CONCRETE FOUNDATION		
		SHAFT DIAMETER	SHAFT DEPTH	TOP PLATE (min)	SHAFT DIAMETER	SHAFT DEPTH	ANCHOR ROD LENGTH ①
<9.1 m (30')	292 (11)	220 (8 5/8)	1.83 m (6')	300 x 300 x 25 12 x 12 x 1	610 (24)	1.52 m (5'-0")	1.45 m (4'-9")
9.4 m - 10.7 m (31'-35')	292 (11)	220 (8 5/8)	1.83 m (6')	300 x 300 x 25 12 x 12 x 1	610 (24)	1.67 m (5'-6")	1.60 m (5'-3")
10.9 m - 12.2 m (36'-40')	381 (15) ③	220 (8 5/8)	1.83 m (6') ②	375 x 375 x 31 15 x 15 x 1 1/4	762 (30)	1.83 m (6'-0")	1.75 m (5'-9")
12.5 m - 13.7 m (41'-45')	381 (15) ③	220 (8 5/8)	1.83 m (6') ②	375 x 375 x 31 15 x 15 x 1 1/4	762 (30)	1.98 m (6'-6")	1.90 m (6'-3")
14.0 m - 15.2 m (46'-50')	381 (15) ③	220 (8 5/8)	2.44 m (8')	375 x 375 x 31 15 x 15 x 1 1/4	762 (30)	2.13m (7'-0")	2.00 m (6'-9")

① Length does not include 100(4)hook
 ② 220 mm x 2.44 m (8 5/8" x 8'-0") for Twin luminaires
 ③ Bolt circle diam. shall be 430 (17) when a TB3-17 transformer base is used

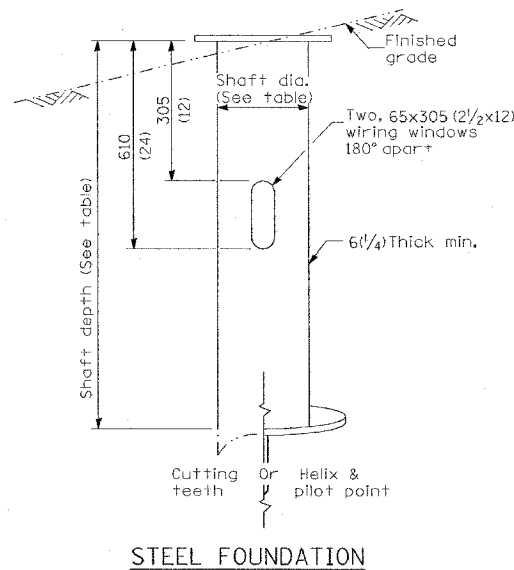
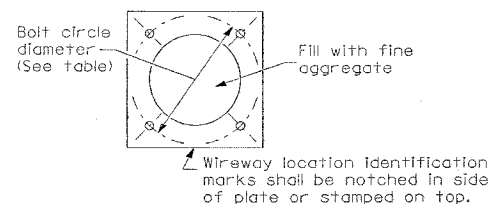

STEEL FOUNDATION

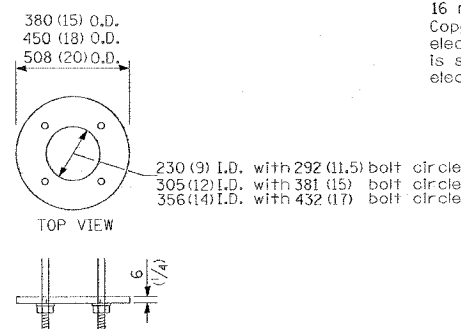

RING PLATE DETAIL
 (When rock is encountered and foundation is shallower)

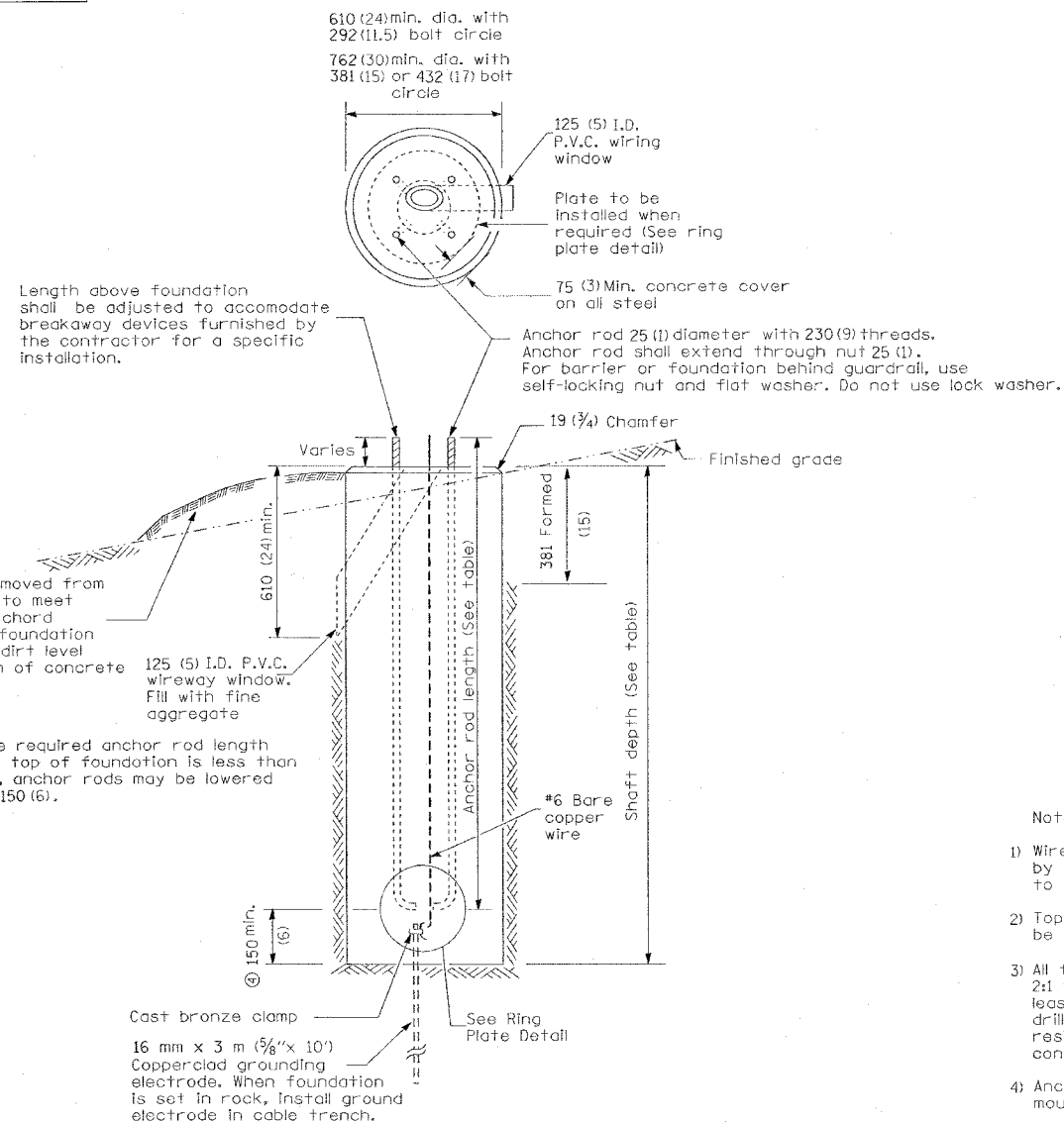

CONCRETE FOUNDATION

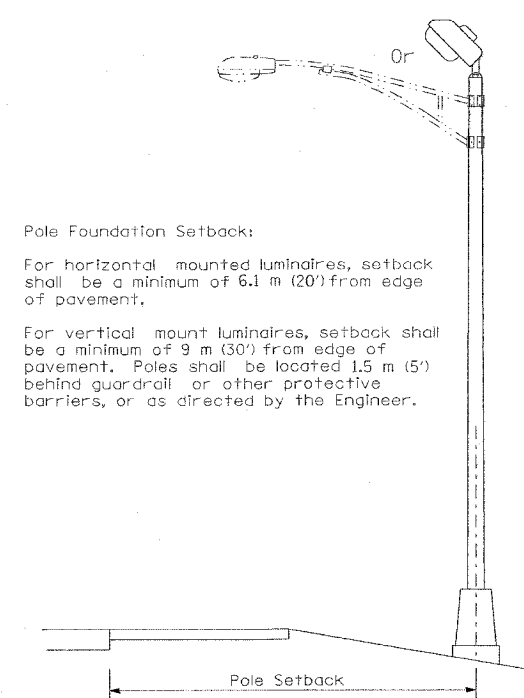

Pole Foundation Setback:
 For horizontal mounted luminaires, setback shall be a minimum of 6.1 m (20') from edge of pavement.
 For vertical mount luminaires, setback shall be a minimum of 9 m (30') from edge of pavement. Poles shall be located 1.5 m (5') behind guardrail or other protective barriers, or as directed by the Engineer.

- Notes:
- 1) Wireway may be on front, back or side of foundation as required by the trenching. Place door of transformer base on wireway side to minimize the number of unit duct bends.
 - 2) Top of schedule 40 125 (5) I.D. PVC wiring window, shall be flush with the top of foundation for drainage.
 - 3) All foundations are designed to be located on slopes not exceeding 2:1 where soils have an unconfined compressive strength of at least 1.0 TSF. The contractor shall verify the soil strength during drilling for concrete foundations or by monitoring installation resistance on steel foundations and notify the engineer if other conditions are encountered.
 - 4) Anchor rod shall be increased to 31 (1 1/4) diameter for 15.24 (50') mounting height or above.
 - 5) TB3-17 transformer base is not to be used on metal foundation

All dimensions are in millimeters (inches) unless otherwise shown.

LGT007-836

REVISIONS		ILLINOIS DEPARTMENT OF TRANSPORTATION
NAME	DATE	
		<p>DETAILS: LIGHT POLE FOUNDATION</p> <p>SCALE: VERT. NONE HORIZ. DATE</p> <p>DRAWN BY CNH CHECKED BY LA</p>

F.A. RTE.	SECTION	COUNTY	TOTAL SHEETS	SHEET NO.
*	**	WILLIAMSON	917	786

STA. TO STA.

FED. ROAD DIST. NO. ILLINOIS FED. AID PROJECT

* I-57, & OLD IL 13 (FAU 9629)

** (X1-6-2)VB-2, (X1-6)HBK-2

"Install and orient arm bracket over pole tenon and firmly hand tighten the two set screws. Use third hole in arm bracket as a guide to drill a 8.3 (3/4) diameter hole through tenon. Install and tighten self-tapping screw. Tighten set screws an additional (1/4 to 3/8) turn with hex key (not provided). Install locknuts on set screws if threaded projection allows."

Pole shall meet AASHTO Standard Specifications for 128.72 km (80 mph) wind loading and 40.82 kg (90 lb.), .37 m² (4.0 sq. ft.) E.P.A. luminaire.

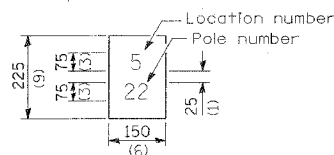

The contractor shall furnish and install a light pole identification of each new light pole, as shown above, incidental to the respective light pole pay item. The numerals shall be 75 (3) series "D", black, screened on silver-white type B pressure sensitive reflective sheeting conforming to the requirements of section T602.01 of the Standard Specifications for Traffic Control Items. The numerals shall conform to the FHWA "Standard Alphabets for Highway Signs".

The light pole identification shall be applied to sign base material as specified in section 719.11 of the Standard Specifications, approximately 180 (7) above the adjacent pavement grade visible to approaching traffic in accordance with Highway Standard 2319.

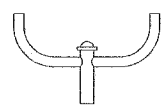

TWIN TENON

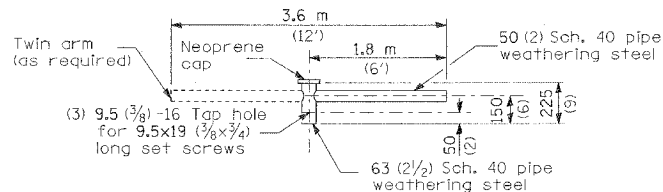

TENON MOUNT BRACKET ARM

NOTE: Single or twin arm assembly shall be tilted 3° above horizontal.

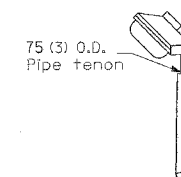

TENON

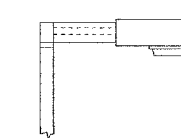

SHORT BRACKET

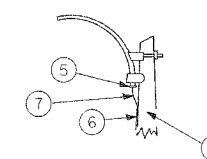

MAST ARM

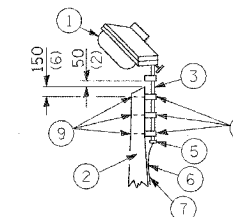

TENON

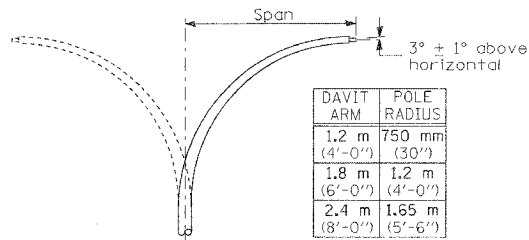

DAVIT ARM	POLE RADIUS
1.2 m (4'-0")	750 mm (30")
1.8 m (6'-0")	1.2 m (4'-0")
2.4 m (8'-0")	1.65 m (5'-6")

DAVIT ARM (and or)
 DAVIT ARM-TWIN

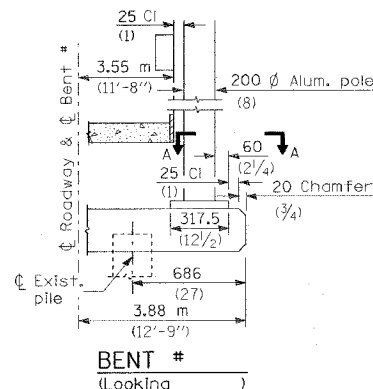

BENT #
(Looking)

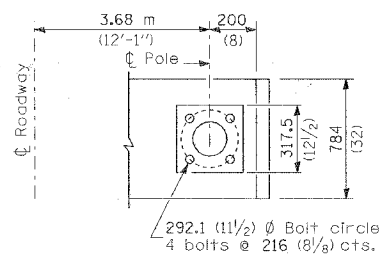

SECTION A-A

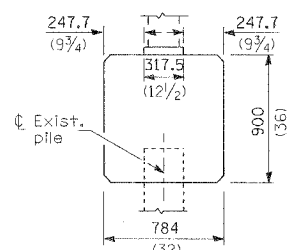

BRIDGE PIER MOUNT

- ① Luminaire
- ② Wood pole, class 3 or better
- ③ 63 (2 1/2) Galv. steel conduit
- ④ Single offset pole band
- ⑤ Conduit bushing
- ⑥ Cable clamps on 600 (24) centers
- ⑦ 2/c #12 Type USE cable
- ⑧ 25 (1) Galv. steel conduit 3.0 m (10') in length

- ⑨ 16 (5/8) diameter hot dipped galvanized bolt with flat washer & locknut (3 req'd)
- ⑩ Conduit clamps on 900 (36) centers
- ⑪ Unit duct
- ⑫ Threaded reducer
- ⑬ "C" Condulet, threaded
- ⑭ 40 (1 1/2) Galv. steel conduit for 1 unit duct or 75 (3) galv. steel conduit for 2 or 3 unit ducts.

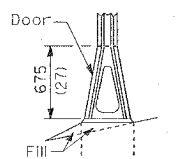

STAINLESS STEEL FLAIR BASE

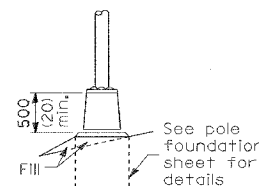

TRANSFORMER BASE

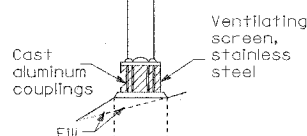

BREAKAWAY COUPLING

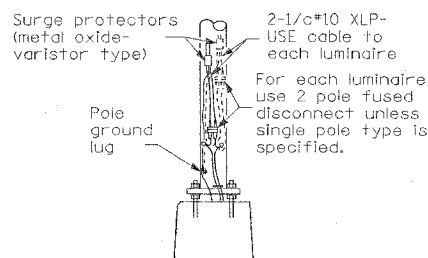

ANCHOR

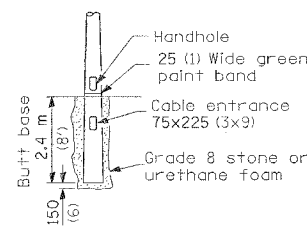

BUTT BASE

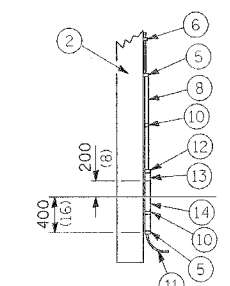

Details for underground distribution if required
 POLE, WOOD

POLE LENGTH	DEPTH IN GROUND
19.8 m (65')	3.6 m (12')
18.0 m (60')	3.0 m (10')
16.8 m (55')	2.7 m (9')
16.0 m (50')	2.4 m (8')
13.7 m (45')	2.1 m (7')
12.0 m (40')	2.0 m (6.5')
10.7 m (35')	1.8 m (6')
9.0 m (30')	1.7 m (5.5')

METAL OR CONCRETE

Details for underground distribution if required

All dimensions are in millimeters (inches) unless otherwise shown.

REVISIONS	
NAME	DATE

ILLINOIS DEPARTMENT OF TRANSPORTATION

**DETAILS:
POLE STANDARDS**

SCALE: VERT. NONE
HORIZ. DATE

DRAWN BY CNH
CHECKED BY LA

LGTO08

F.A. RTE.	SECTION	COUNTY	TOTAL SHEETS	SHEET NO.
*	**	WILLIAMSON	917	787
STA. TO STA.				
FED. ROAD DIST. NO. ILLINOIS FED. AID PROJECT				
* I-57, & OLD IL 13 (FAU 9629)				
** (X1-6-2)VB-2, (X1-6)HBK-2				

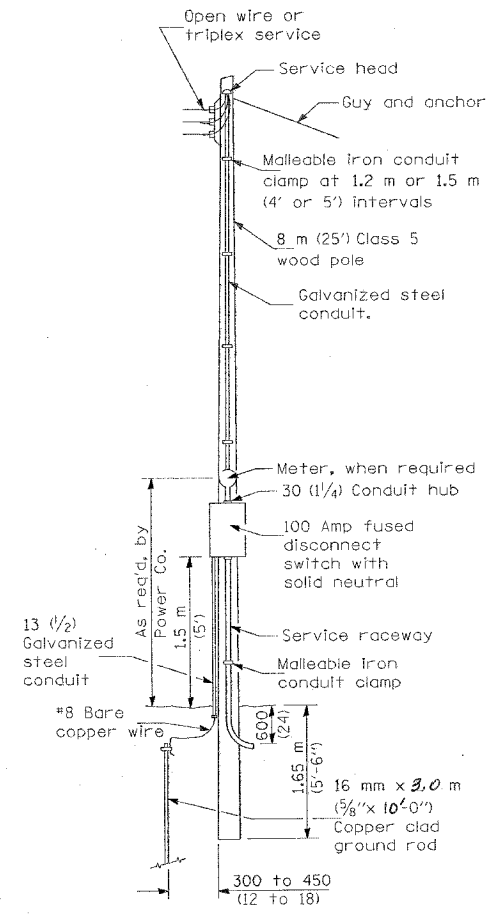

SERVICE POLE

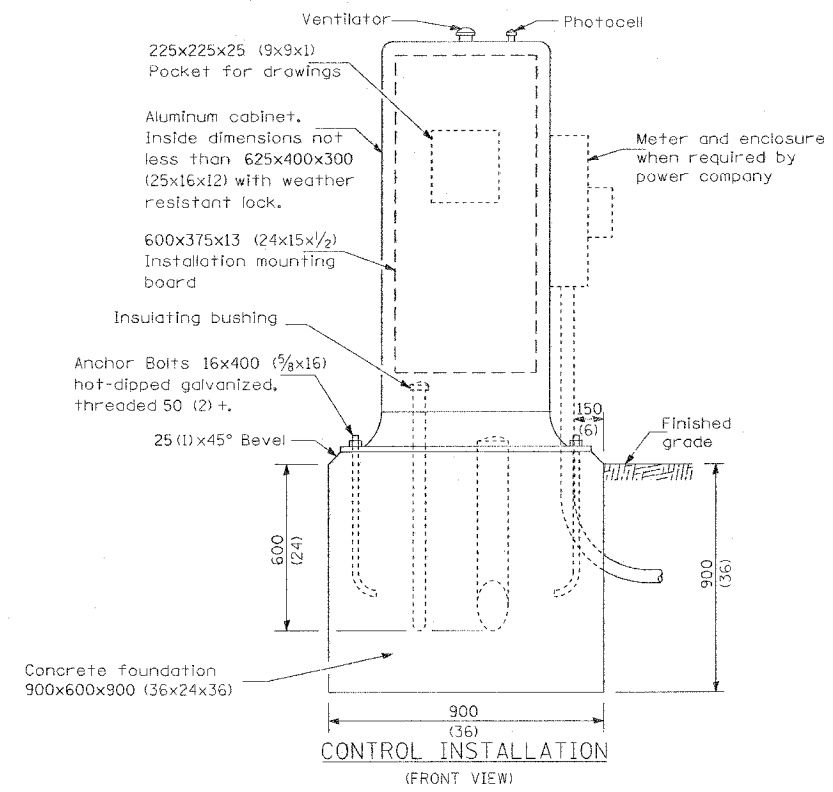

CONTROL INSTALLATION (FRONT VIEW)

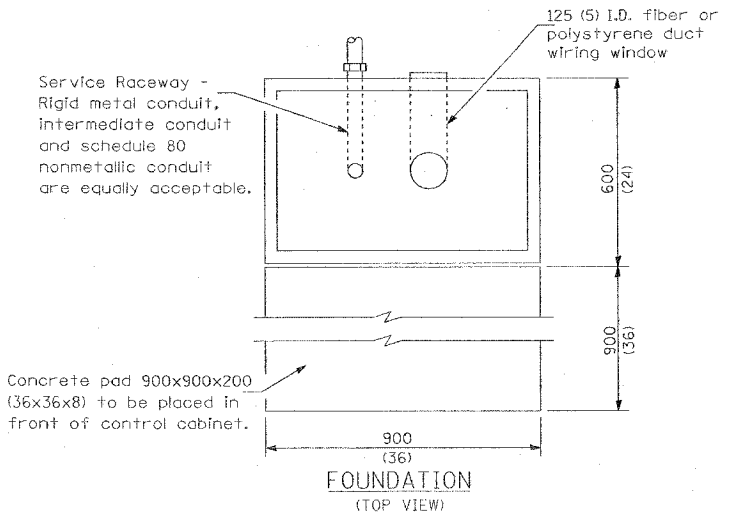

FOUNDATION (TOP VIEW)

- A Selector switch
- B 2 Pole 100 amp 240V contactor
- C 2 Pole 100 amp MAIN disconnect
- D,E,F 2 Pole 30 amp breakers
- G Photocell w/integral surge arrester variable voltage

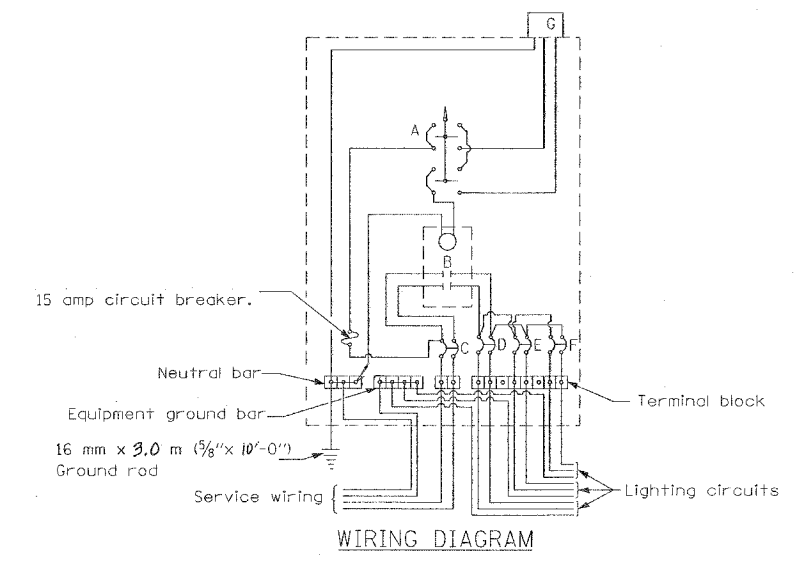

WIRING DIAGRAM

GENERAL NOTES

Locate service pole and control installation adjacent to R.O.W. line with a minimum distance of 9 m (30') from the edge of pavement. Exact location shall be established by the Engineer.

The underground service entrance wiring shall not exceed 46 m (150'). Total aerial and underground service between the control installation and primary transformer shall not exceed 76 m (250').

Raceways shall terminate 75 (3) above top of concrete foundation.

- 240 V. SERVICE
- 480 V. SERVICE

All dimensions are in millimeters unless otherwise shown.

REVISIONS	
NAME	DATE

ILLINOIS DEPARTMENT OF TRANSPORTATION

DETAILS:
CONTROL INSTALLATION
TYPE CB-RCS-100

SCALE: VERT. NONE
HORIZ. DATE

DRAWN BY CNH
CHECKED BY LA

Rev. LGT005

PLOT DATE = 10/13/2005
FILE NAME = c:\nc\joe\va\98950\vol13\vol13.dwg
USER NAME = jacob

F.A. RTE.	SECTION	COUNTY	TOTAL SHEETS	SHEET NO.
*	**	WILLIAMSON	917	788
STA.		TO STA.		
FED. ROAD DIST. NO.		ILLINOIS FED. AID PROJECT		

* I-57, & OLD IL 13 (FAU 9629)
 ** (X1-6-2)VB-2,(X1-6)HBK-2

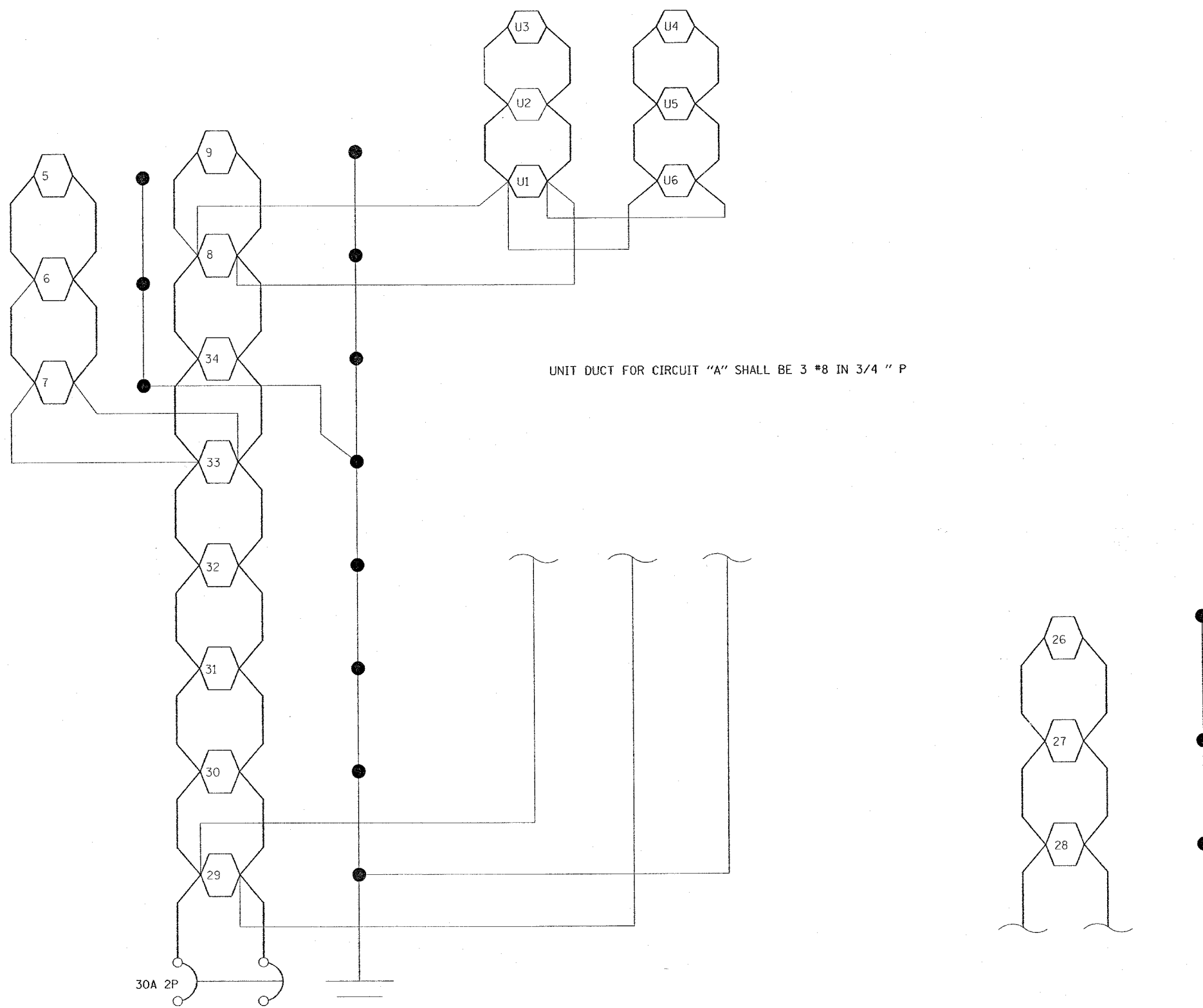

UNIT DUCT FOR CIRCUIT "A" SHALL BE 3 #8 IN 3/4 " P

REVISIONS	
NAME	DATE

ILLINOIS DEPARTMENT OF TRANSPORTATION

CIRCUIT "A"

SCALE: VERT. NONE
 HORIZ. NONE

DATE: _____

DRAWN BY CNH
 CHECKED BY LA

PLOT DATE = 11/28/2006
 FILE NAME = \\spsc01\apps\p02802\vid13\vid13p12.dgn
 PLOT SCALE = 50.0000 / IN.
 USER NAME = hseidn

F.A. RTE.	SECTION	COUNTY	TOTAL SHEETS	SHEET NO.
*	**	WILLIAMSON	917	789
STA.		TO STA.		
FED. ROAD DIST. NO.		ILLINOIS FED. AID PROJECT		
* 1-57, & OLD IL 13 (FAU 9629)				
* * (X1-6-2)VB-2,(X1-6)HBK-2				

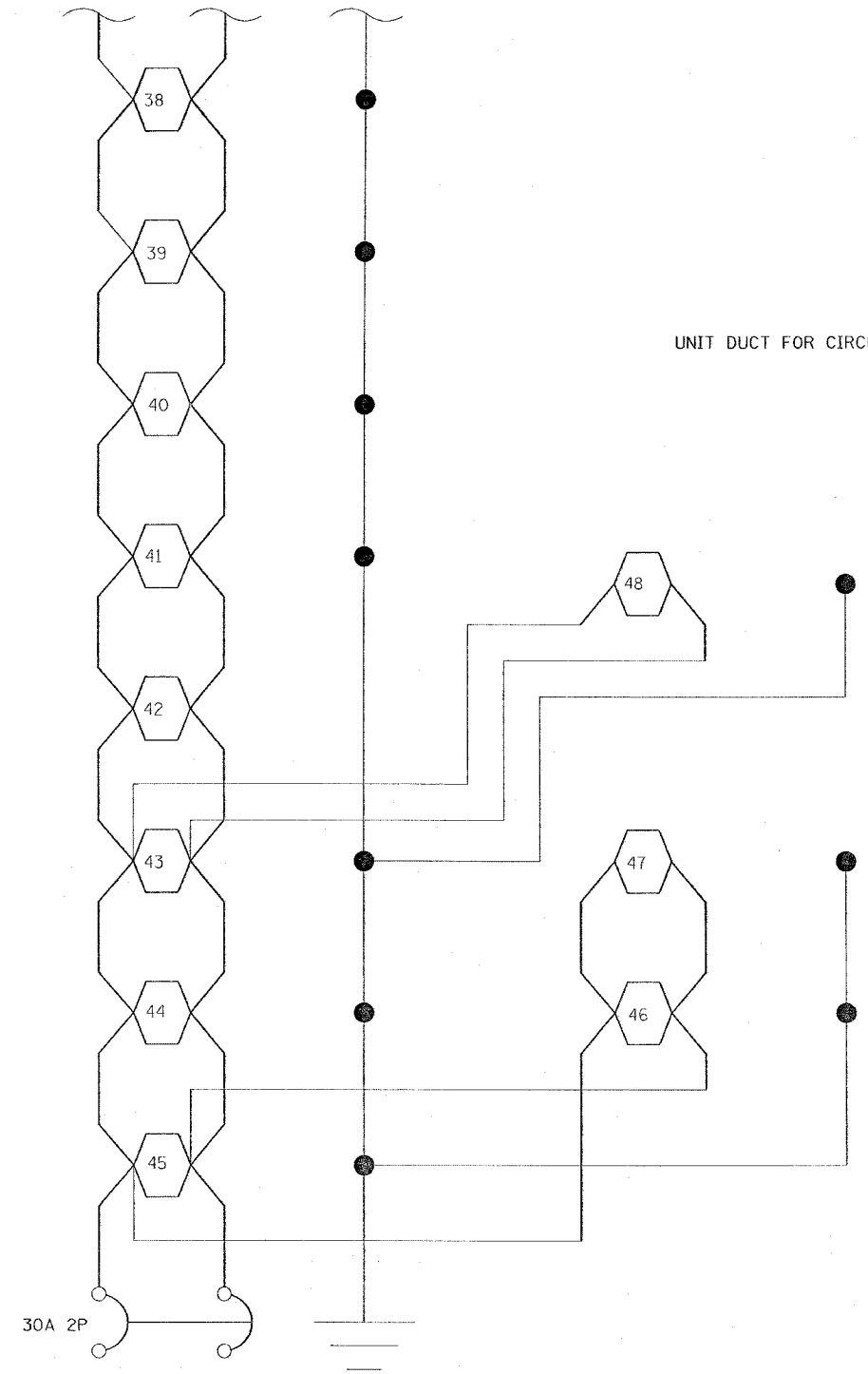

UNIT DUCT FOR CIRCUIT "B" SHALL BE 3 *4 IN 1" P

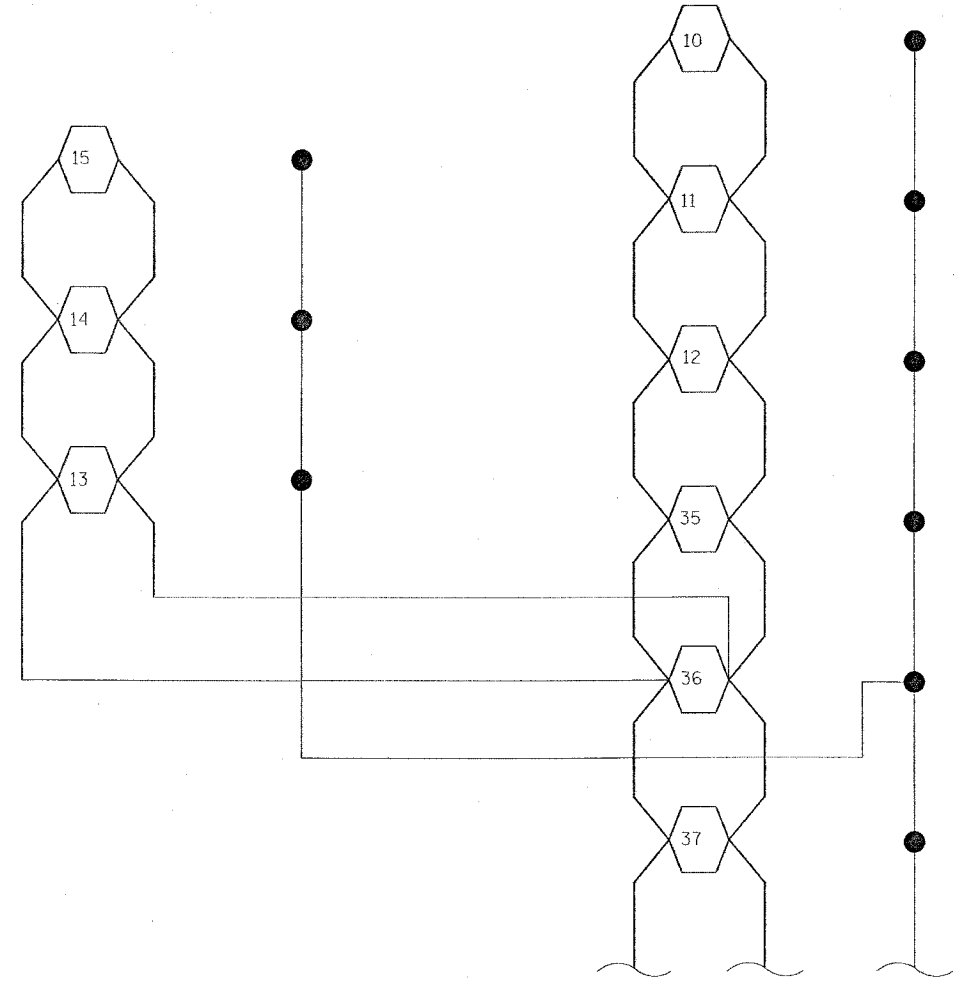

PLOT DATE = 10/13/2006
 FILE NAME = c:\projects\98950\vol1\3\vol1\3pl5.dgn
 USER NAME = hessan

REVISIONS	
NAME	DATE

ILLINOIS DEPARTMENT OF TRANSPORTATION

CIRCUIT "B"

SCALE: VERT. NONE
 HORIZ. NONE

DATE _____

DRAWN BY CNH
 CHECKED BY LA

CONTRACT NO. 98950

F.A. RTE.	SECTION	COUNTY	TOTAL SHEETS	SHEET NO.
*	**	WILLIAMSON	917	790

STA.	TO STA.

FED. ROAD DIST. NO. ILLINOIS FED. AID PROJECT
 * I-57, & OLD IL 13 (FAU 9629)
 * * (X1-6-2)VB-2,(X1-6)HBK-2

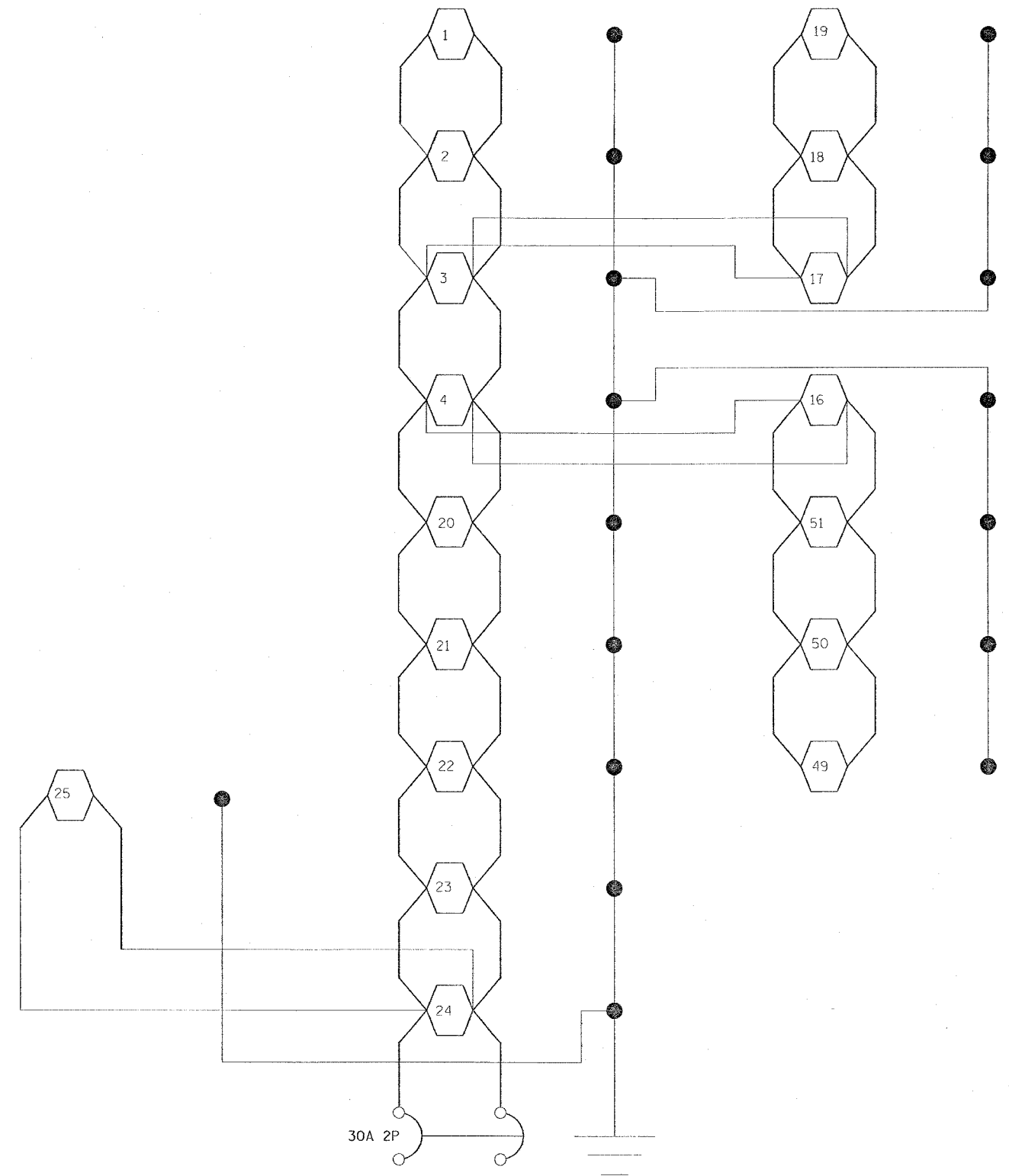

UNIT DUCT FOR CIRCUIT "C" SHALL BE 3 *6 IN 1" P

PLOT DATE = 10/13/2006
 FILE NAME = c:\pwork\joeva\98950\13\old\13p12.dgn
 PLOT SCALE = 50.0000 * / IN.
 USER NAME = joeson

REVISIONS	
NAME	DATE

ILLINOIS DEPARTMENT OF TRANSPORTATION

CIRCUIT "C"

SCALE: VERT. NONE
 HORIZ. NONE

DATE: _____

DRAWN BY CNH
 CHECKED BY LA

ROUTE NO.	SEC.	COUNTY	TOTAL SHEETS	SHEET NO.
F.A.I. 57	*	WILLIAMSON	18	14
FED. ROAD DIST. NO. 7	ILLINOIS	PROJECT		
* XI-6, XI-7-1 L-1				

CONTRACT NO. 98950				
SECTION	COUNTY	TOTAL SHEETS	SHEET NO.	
#	#	WILLIAMSON	917	790A
STA.	TO STA.			
FED. ROAD DIST. NO. 7	ILLINOIS	FED. AID PROJECT		
* I-57, & OLD IL 13 (FAU 9629)				
* (XI-6-2)VB-2, (XI-6)HBK-2				

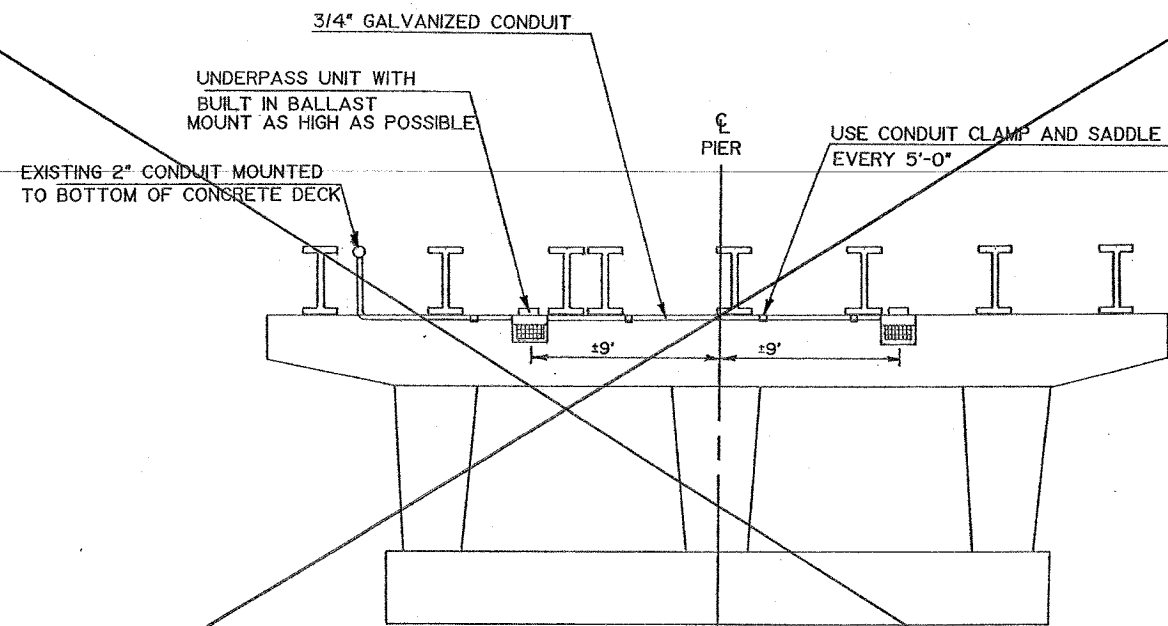

TYPICAL ILLINOIS ROUTE 13 STRUCTURES
UNDERPASS LIGHTING
(MOUNTED ON FACE OF PIER)

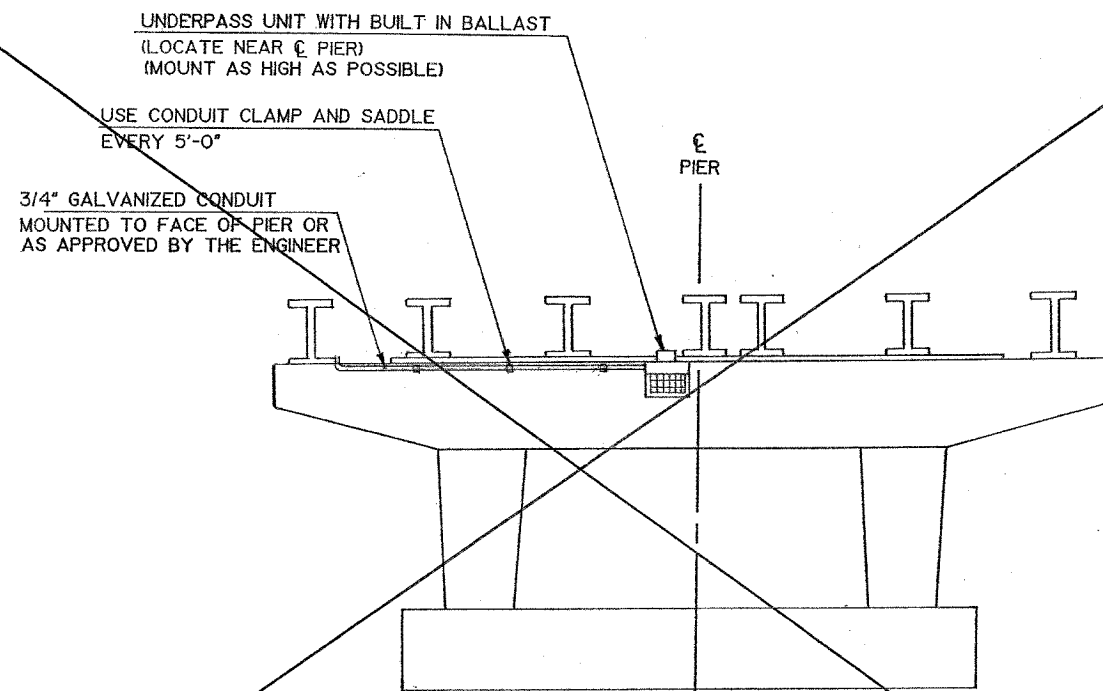

TYPICAL OLD ROUTE 13 (MAIN STREET) STRUCTURES
UNDERPASS LIGHTING
(MOUNTED ON FACE OF PIER)

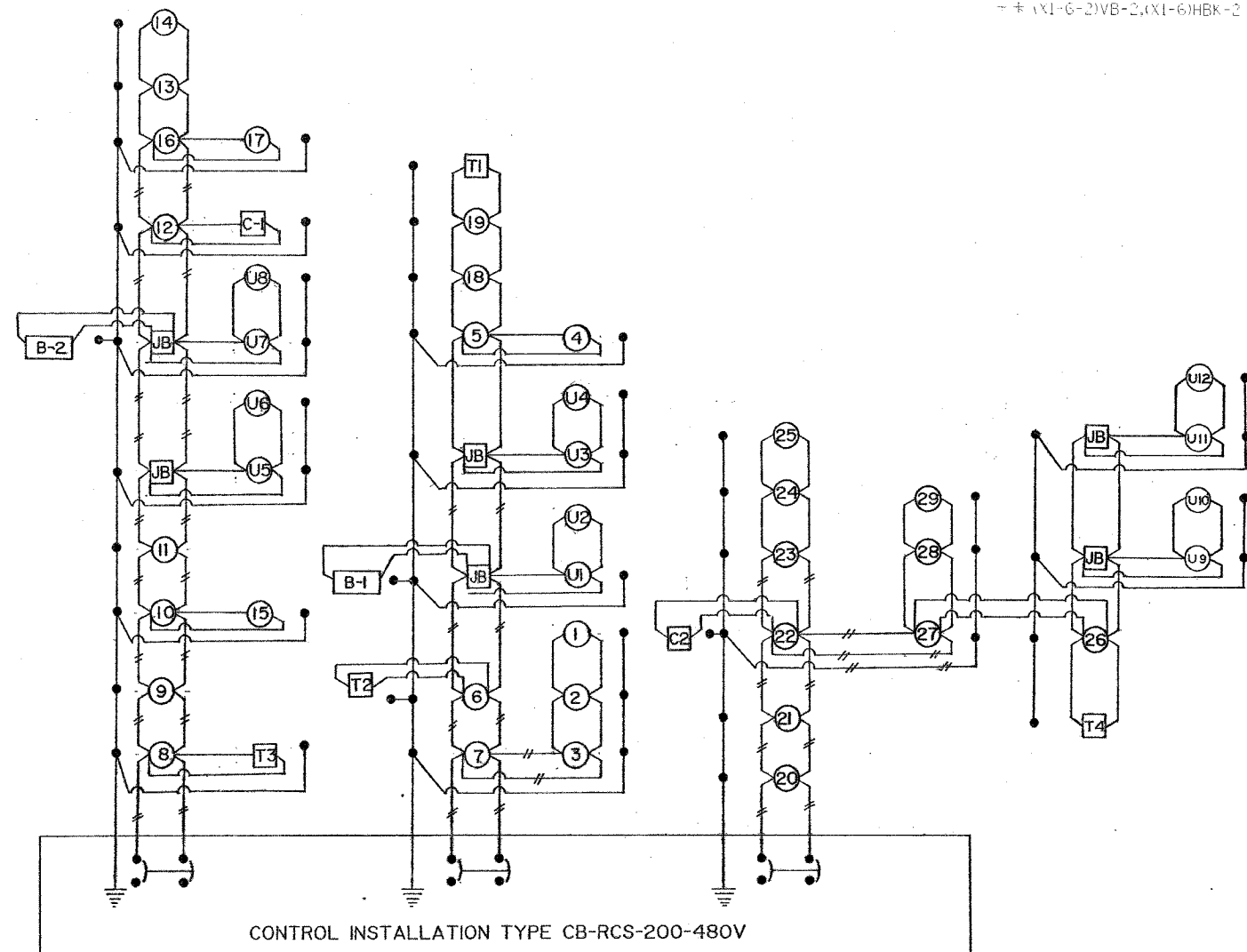

WIRING DIAGRAM
LOCATION NO. 1

FOR INFORMATION ONLY!

F.A. RTE.	SECTION	COUNTY	TOTAL SHEETS	SHEET NO.
*	**	WILLIAMSON	917	791
STA.		TO STA.		
FED. ROAD DIST. NO.		ILLINOIS FED. AID PROJECT		
		* I-57, & OLD IL 13 (FAU 9629)		
		** (X1-6-2)VB-2,(X1-6)HBK-2		

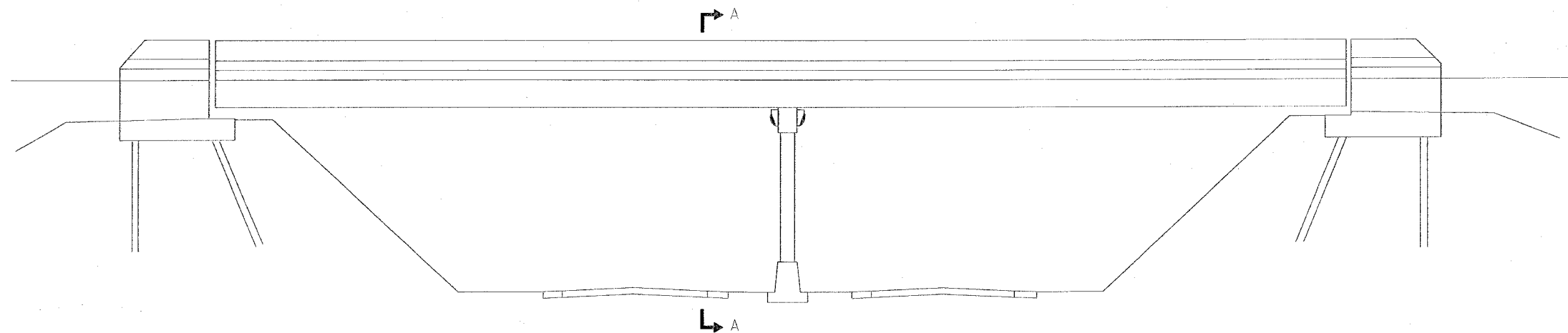

OVERPASS ELEVATION
(Not to Scale)

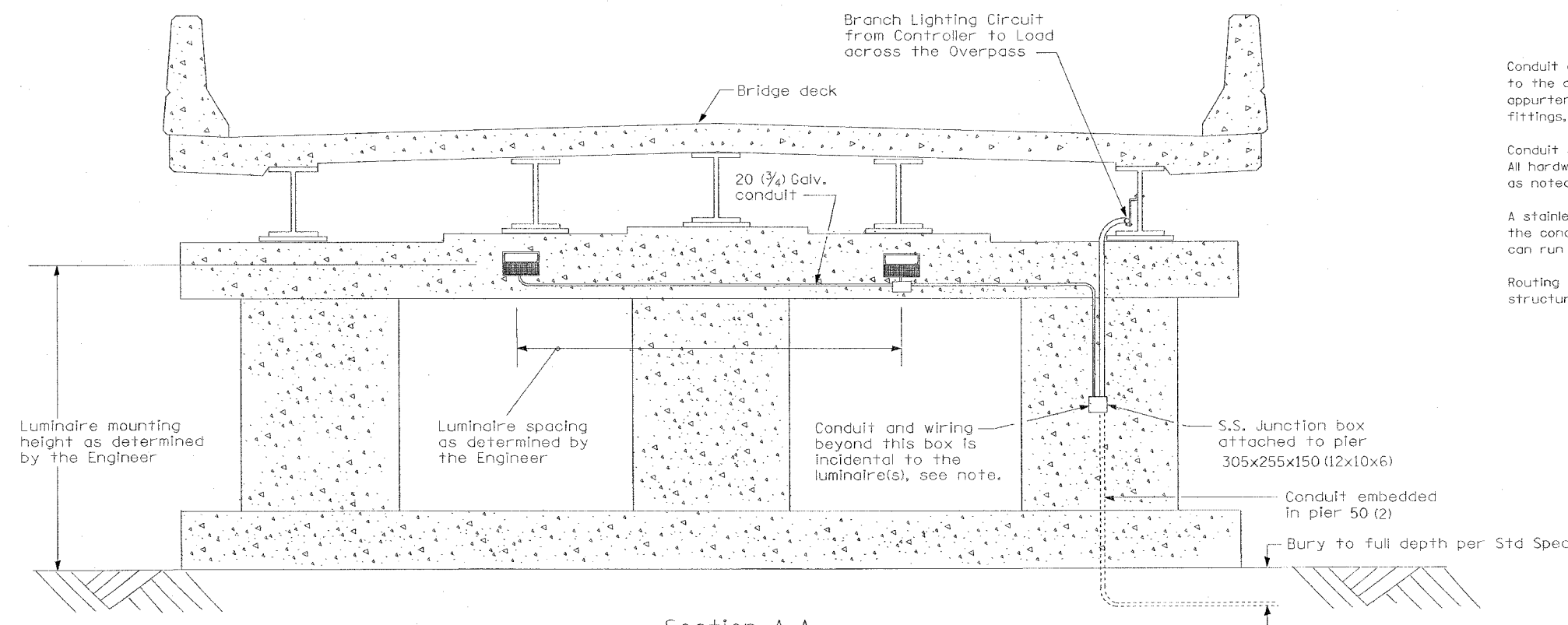

Section A-A
(Underpass Lighting on Pier)

All dimensions are in millimeters (inches) unless otherwise shown.

GENERAL NOTES

Conduit and wiring to the underpass luminaire(s) shall be incidental to the cost of the underpass luminaire(s). This includes all appurtenances including, but not limited to; straps, clamps, hangers, fittings, attachments, hardware, etc.

Conduit shall be rigid galvanized conduit unless noted otherwise. All hardware shall be stainless steel and all conduit appurtenances, as noted above, shall be hot dip galvanized or stainless steel.

A stainless steel junction box and flex conduit shall be installed in the conduit at any opening in the bridge deck where road salt can run down onto the conduit system.

Routing and method of attachment of the conduit on the bridge structure and across piers shall be as approved by the Engineer.

REVISIONS	
NAME	DATE
Corrected	4/3/06

ILLINOIS DEPARTMENT OF TRANSPORTATION

**DETAILS:
UNDERPASS LIGHTING
WITH CENTER PIER**

SCALE: VERT. NONE
HORIZ. NONE

DRAWN BY CNH
CHECKED BY LA

LGT019B.M32

DATE = 10/13/2005
FILE NAME = c:\p022822\01\13\01\13\01.dgn
PLOT SCALE = 50.0000 / 1 IN.
USER NAME = heshan

F.A. RTE.	SECTION	COUNTY	TOTAL SHEETS	SHEET NO.
*	**	WILLIAMSON	917	792

STA. TO STA.

FED. ROAD DIST. NO. ILLINOIS FED. AID PROJECT

* I-57, & OLD IL 13 (FAU 9629)

** (X1-6-2)VB-2,(X1-6)HBK-2

LIGHT POLE MOUNTED ON CONCRETE PARAPET

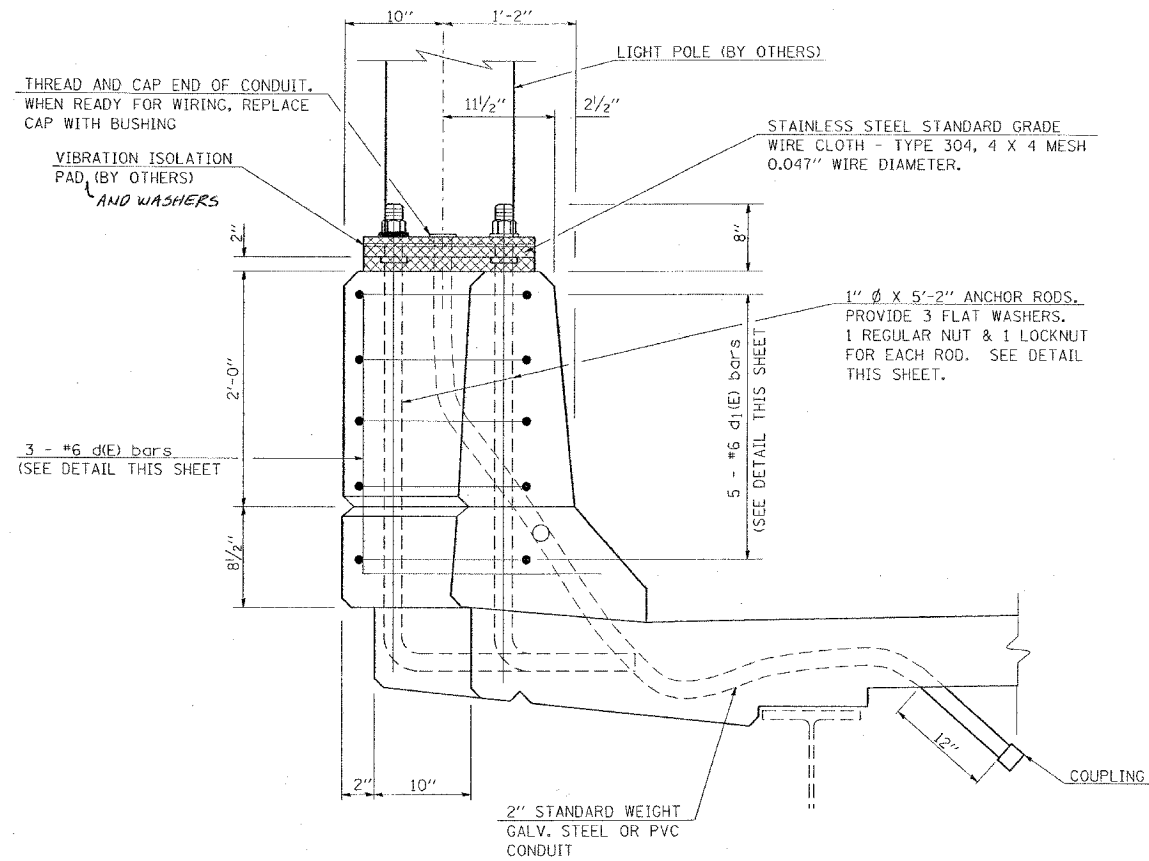

SECTION A-A

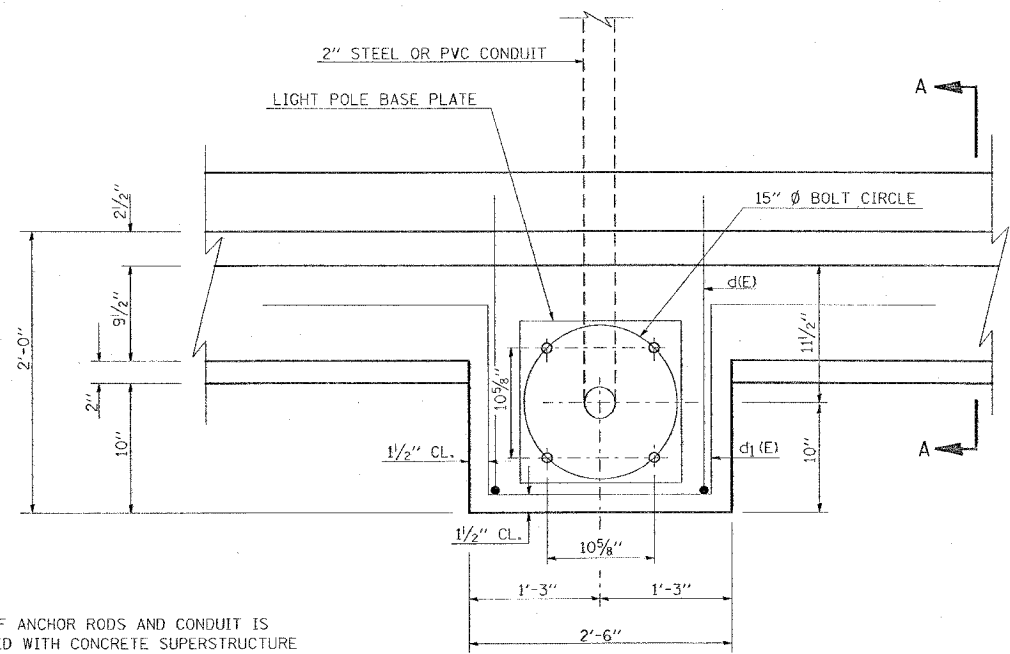

PLAN

NOTE: COST OF ANCHOR RODS AND CONDUIT IS INCLUDED WITH CONCRETE SUPERSTRUCTURE

LIGHT PEDESTAL REINFORCEMENT

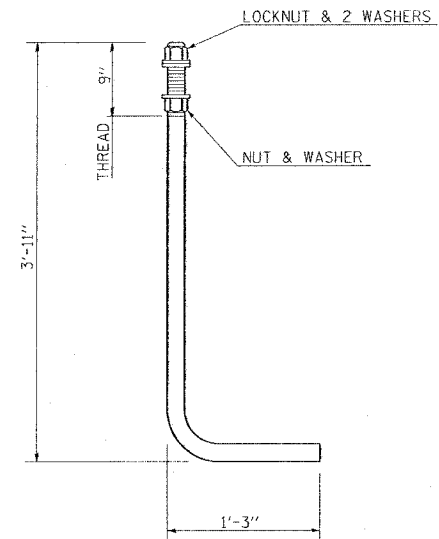

1" Ø ANCHOR ROD
(ASTM F 1554 GRADE 105)

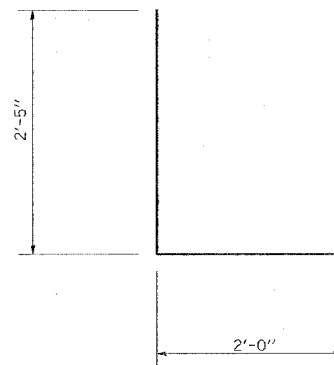

BAR d(E)

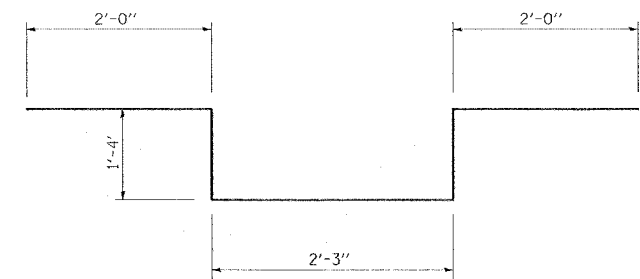

BAR d₁(E)

REVISIONS	
NAME	DATE

ILLINOIS DEPARTMENT OF TRANSPORTATION

DETAILS:
LIGHT POLE MOUNTED ON CONCRETE PARAPET
LIGHT PEDESTAL REINFORCEMENT

SCALE: VERT. NONE
HORIZ. DATE

DRAWN BY CNH
CHECKED BY LA

F.A. RTE.	SECTION	COUNTY	TOTAL SHEETS	SHEET NO.
*	**	WILLIAMSON	917	793

STA.	TO STA.
FED. ROAD DIST. NO.	ILLINOIS FED. AID PROJECT

* I-57, & OLD IL 13 (FAU 9629)
 ** (X1-6-2)VB-2,(X1-6)HBK-2

CONDUIT IN PARAPET DETAILS
 SN 100-0087 (SB)

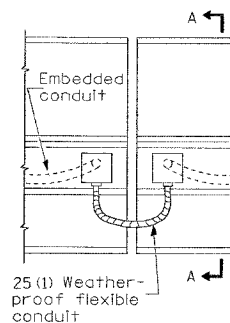

ELEVATION AT EXPANSION JOINT

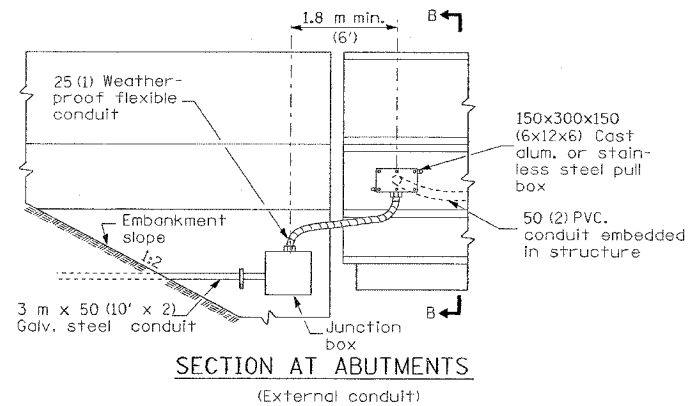

CONDUIT ATTACHED TO STRUCTURE DETAILS
 SN 100-0084 (NB) AND SN 100-0085 (SB)

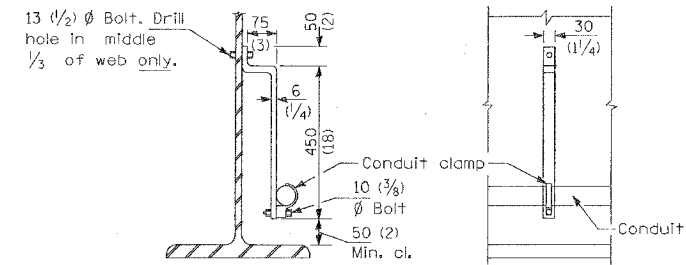

CONDUIT SUPPORT BRACKET

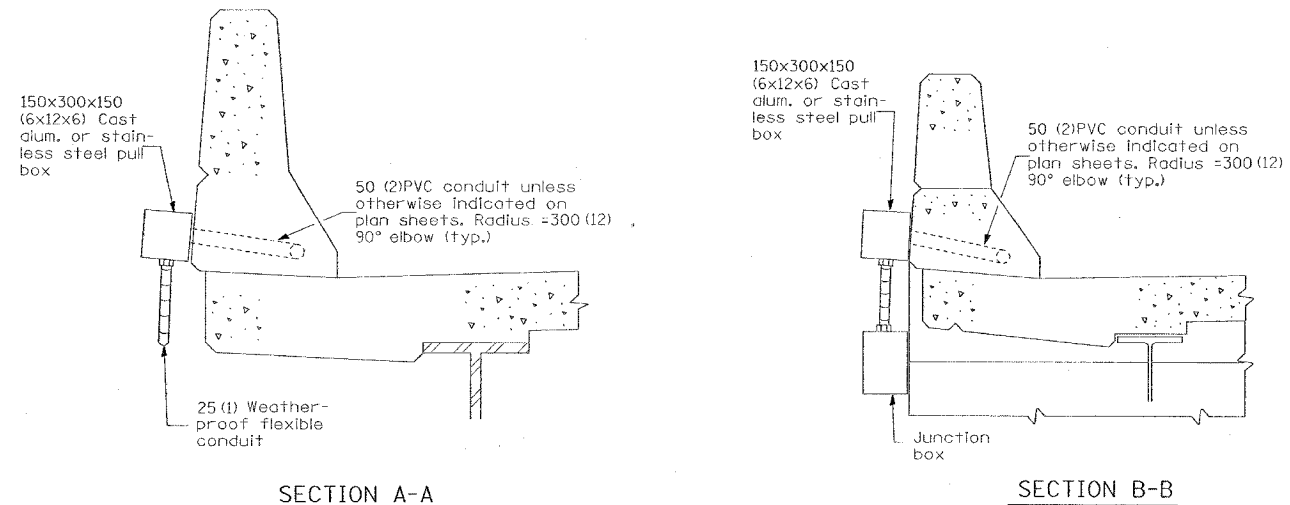
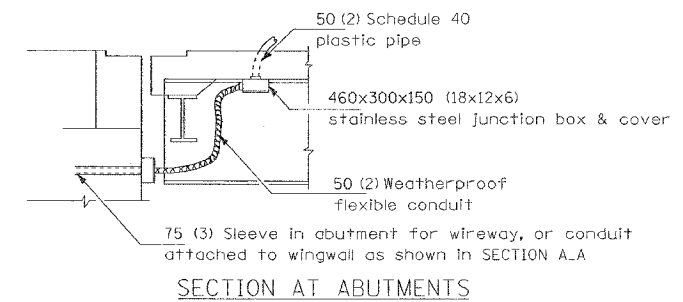
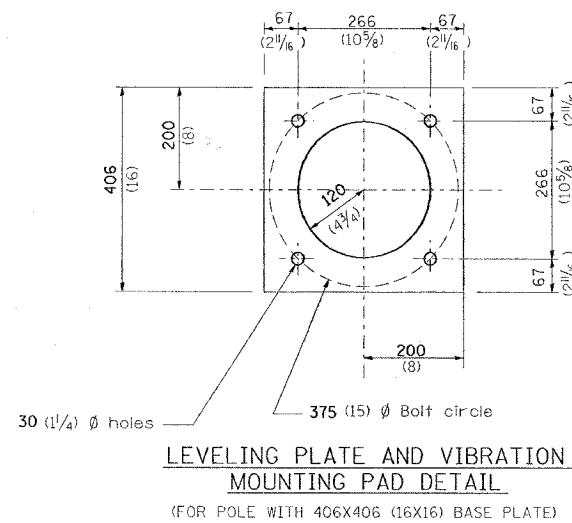

All dimensions are in millimeters (inches) unless otherwise shown.

All dimensions are in millimeters (inches) unless otherwise shown.

REVISIONS	
NAME	DATE

ILLINOIS DEPARTMENT OF TRANSPORTATION

DETAILS:
CONDUIT IN PARAPET;
CONDUIT ATTACHED TO STRUCTURE

SCALE: VERT. NONE
 HORIZ. DATE

DRAWN BY CNH
 CHECKED BY

DATE	ISSUE NO.	PROJECT	TOTAL SHEETS	SHEET NO.
*		Williamson	917	793A.
FED. ROAD DIST. NO. 7		ILLINOIS PROJECT		

*I-57 & OLD IL 13

ILLINOIS DEPARTMENT OF TRANSPORTATION
LUMINAIRE PERFORMANCE TABLE

GIVEN CONDITIONS		
ROADWAY DATA:	Pavement Width	24 FT
	Number Of Lanes	2
	Median Width	18 FT
	IES Surface Classification	R3
	Q-Zero Value	.07
LIGHT POLE DATA:	Mounting Height	45 FT
	Mast Arm Length	15 FT
	Pole Set-Back From Edge Of Pavement	20 FT
LUMINAIRE DATA:	Lamp Type	HPS
	Lamp Lumens	28,000
	IES Vertical Distribution	M
	IES Control Of Distribution	FC
	IES Lateral Distribution	III
	Total Light Loss Factor	0.684
LAYOUT DATA:	Spacing	175 FT
	Configuration	OPP.
	Luminaire Overhang Over Edge Of Pavement Lane	-5 FT

NOTE: Variations from the above specified IES distribution pattern may be requested and acceptance of variations will be subject to review by the Engineer based on how well the performance requirements are met.

PERFORMANCE REQUIREMENTS

NOTE: These performance requirements shall be the minimum acceptable standards of photometric performance for the luminaire, based on the given conditions listed above.

ILLUMINATION:	Average Horizontal Illumination, (E_{AVE})	9 Lux
	Uniformity Ratio, (E_{AVE}/E_{MIN})	3
LUMINANCE:	Average Luminance: (L_{AVE})	0.6 Cd/m ²
	Uniformity Ratios: (L_{AVE}/L_{MIN})	3.5
	(L_{MAX}/L_{MIN})	6.0
	Maximum Veiling Luminance Ratio: (L_v/L_{AVE})	0.3

ILLINOIS DEPARTMENT OF TRANSPORTATION
UNDERPASS LUMINAIRE PERFORMANCE TABLE

GIVEN CONDITIONS		
ROADWAY DATA:	Pavement Width	24 FT
	Number Of Lanes	2
	Median Width	18 FT
	IES Surface Classification	R3
	Q-Zero Value	.07
MOUNTING DATA:	Mounting Height	16 FT
	Set-Back From Edge Of Pavement	7.5 FT
	Mounting Type	Pier
LUMINAIRE DATA:	Lamp Type	HPS
	Lamp Lumens	15,000
	IES Vertical Distribution	S
	IES Control Of Distribution	NC
	IES Lateral Distribution	IV
	Maximum Candela Angle	75 DEG
	Total Light Loss Factor	0.684
LAYOUT DATA:	Spacing	50 FT
	Configuration	1 side only

NOTE: Variations from the above specified IES distribution pattern may be requested and acceptance of variations will be subject to review by the Engineer based on how well the performance requirements are met.

PERFORMANCE REQUIREMENTS

NOTE: These performance requirements shall be the minimum acceptable standards of photometric performance for the luminaire, based on the given conditions listed above.

ILLUMINATION:	Average Horizontal Illumination, (E_{AVE})	9 Lux
	Uniformity Ratio, (E_{AVE}/E_{MIN})	3
LUMINANCE:	Average Luminance: (L_{AVE})	0.6 Cd/m ²
	Uniformity Ratios: (L_{AVE}/L_{MIN})	3.5
	(L_{MAX}/L_{MIN})	6.0
	Maximum Veiling Luminance Ratio: (L_v/L_{AVE})	0.3

ILLINOIS DEPARTMENT OF TRANSPORTATION
LUMINAIRE PERFORMANCE TABLE

GIVEN CONDITIONS		
ROADWAY DATA:	Pavement Width	36 FT
	Number Of Lanes	3
	Median Width	40 FT
	IES Surface Classification	R3
	Q-Zero Value	.07
LIGHT POLE DATA:	Mounting Height	50 FT
	Mast Arm Length	15 FT
	Pole Set-Back From Edge Of Pavement	20 FT
LUMINAIRE DATA:	Lamp Type	HPS
	Lamp Lumens	28,000
	IES Vertical Distribution	M
	IES Control Of Distribution	FC
	IES Lateral Distribution	III
	Total Light Loss Factor	0.684
LAYOUT DATA:	Spacing	285 FT
	Configuration	OPP.
	Luminaire Overhang Over Edge Of Pavement Lane	-5 FT

NOTE: Variations from the above specified IES distribution pattern may be requested and acceptance of variations will be subject to review by the Engineer based on how well the performance requirements are met.

PERFORMANCE REQUIREMENTS

NOTE: These performance requirements shall be the minimum acceptable standards of photometric performance for the luminaire, based on the given conditions listed above.

ILLUMINATION:	Average Horizontal Illumination, (E_{AVE})	9 Lux
	Uniformity Ratio, (E_{AVE}/E_{MIN})	3
LUMINANCE:	Average Luminance: (L_{AVE})	0.6 Cd/m ²
	Uniformity Ratios: (L_{AVE}/L_{MIN})	3.5
	(L_{MAX}/L_{MIN})	6.0
	Maximum Veiling Luminance Ratio: (L_v/L_{AVE})	0.3

LIGHTING DETAILS
PERFORMANCE TABLES

I-57 & OLD IL 13
WILLIAMSON COUNTY

F.A. RTE.	SECTION	COUNTY	TOTAL SHEETS	SHEET NO.
*	**	WILLIAMSON	917	794

STA.	TO STA.

FED. ROAD DIST. NO. ILLINOIS FED. AID PROJECT

* I-57, & OLD IL 13 (FAU 9629)
 * (X1-6-2)VB-2, (X1-6)HKB-2

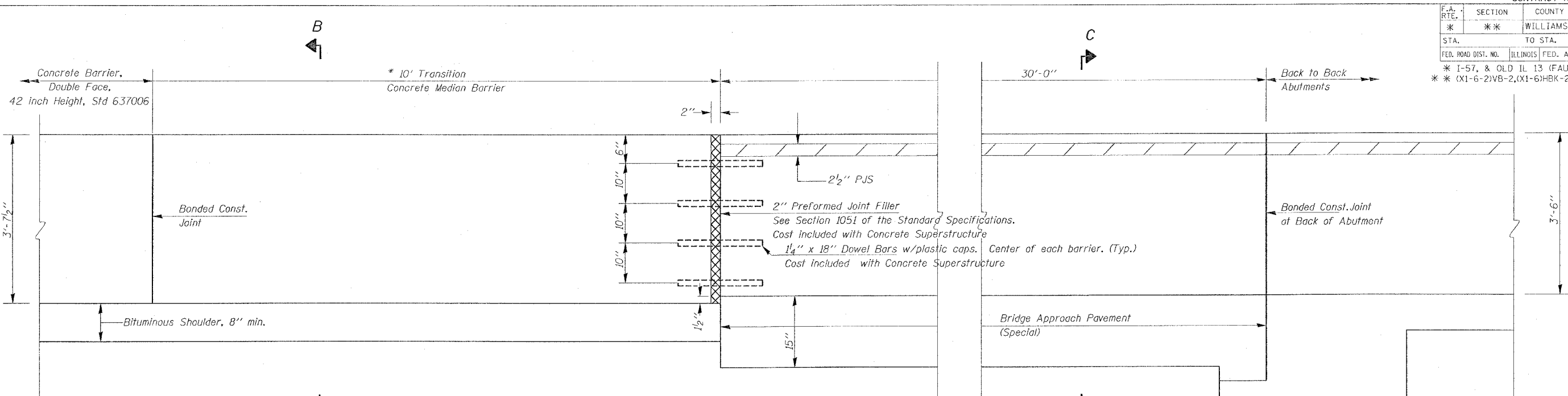

SECTION A-A THRU CENTERLINE OF CONCRETE MEDIAN BARRIER

* THE COST OF THIS 10' TRANSITION CONCRETE MEDIAN BARRIER (FOUR LOCATIONS) SHALL BE INCLUDED IN THE OVERALL LENGTH MEASURED FOR CONCRETE BARRIER, DOUBLE FACE, 42 INCH HEIGHT. SEE SECTION 637 OF THE STANDARD SPECIFICATIONS FOR ADDITIONAL REQUIREMENTS.

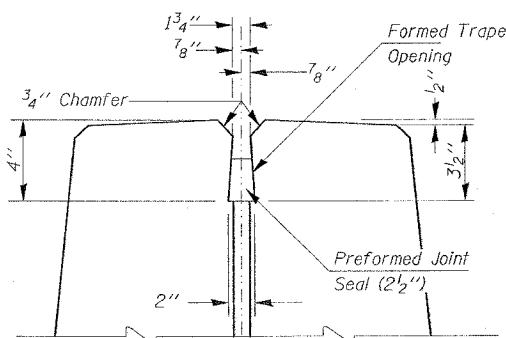

DETAIL A

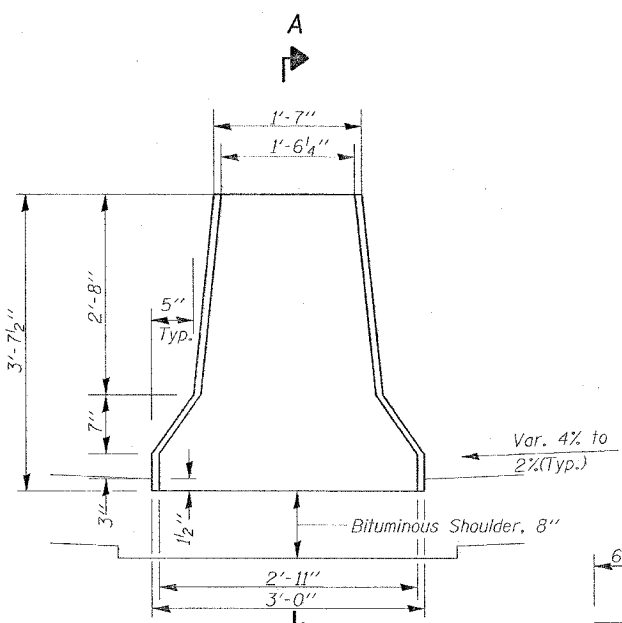

SECTION B-B

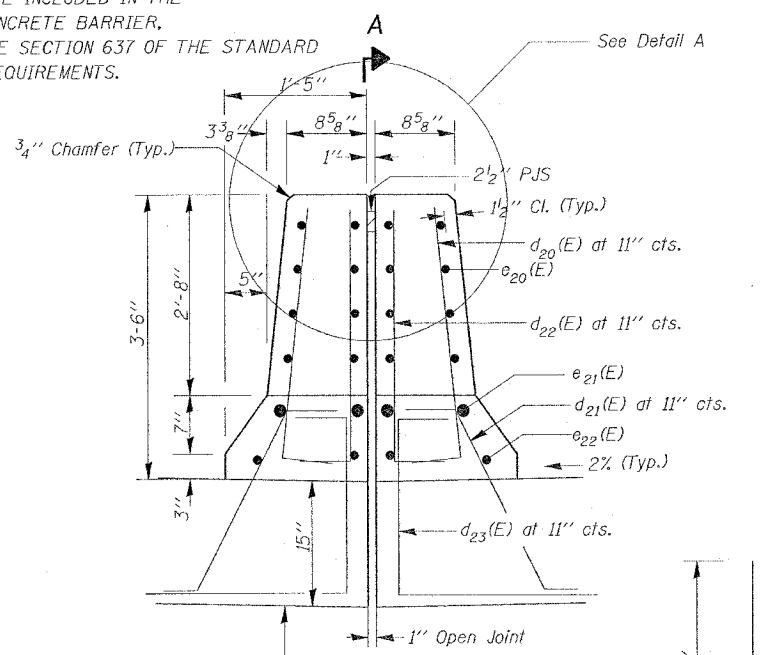

SECTION C-C

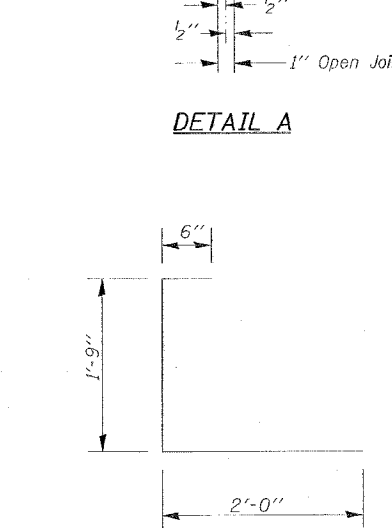

BARS d23(E)

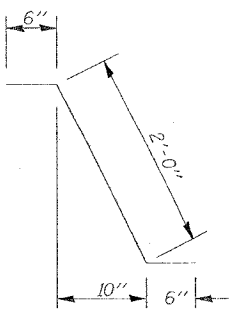

BARS d21(E)

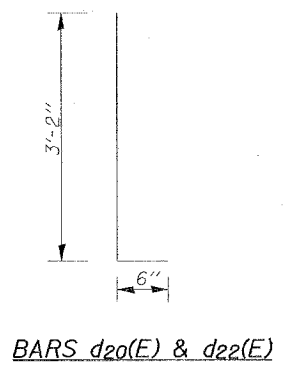

BARS d20(E) & d22(E)

BILL OF MATERIAL
(Four Locations)

Bar	No.	Size	Length	Shape
d ₂₀ (E)	272	#5	3'-8"	
d ₂₁ (E)	272	#5	3'-0"	
d ₂₂ (E)	272	#4	3'-8"	
d ₂₃ (E)	272	#4	4'-3"	
e ₂₀ (E)	64	#4	29'-8"	
e ₂₁ (E)	16	#8	29'-8"	
e ₂₂ (E)	16	#5	29'-8"	
Preformed Joint Seal 2 1/2"	Foot		120	
Concrete Superstructure	Cu. Yd.		29.8	
Reinforcement Bars, Epoxy Coated	Lbs.		6360	

Reinforcement bars designated (E) shall be epoxy coated.

REVISIONS	
NAME	DATE

ILLINOIS DEPARTMENT OF TRANSPORTATION
30' CONCRETE MEDIAN BARRIER
ON THE BRIDGE APPROACH
PAVEMENT (SPECIAL)

SCALE: VERT. NO SCALE
 HORIZ. DATE
 DRAWN BY WH
 CHECKED BY

PLT DATE = 10/13/2006
 FILE NAME = c:\pvc\meca\982802\013\013\013\013.dgn
 PLOT SCALE = 80.0000 / 1 IN.
 USER NAME = hender

F.A. RTE.	SECTION	COUNTY	TOTAL SHEETS	SHEET NO.
*	**	WILLIAMSON	917	795
STA.		TO STA.		
FED. ROAD DIST. NO.		ILLINOIS FED. AID PROJECT		
* I-57, & OLD IL 13 (FAU 9629)				
** (X1-6-2)VB-2,(X1-6)HBK-2				

RETAINING WALL DETAIL

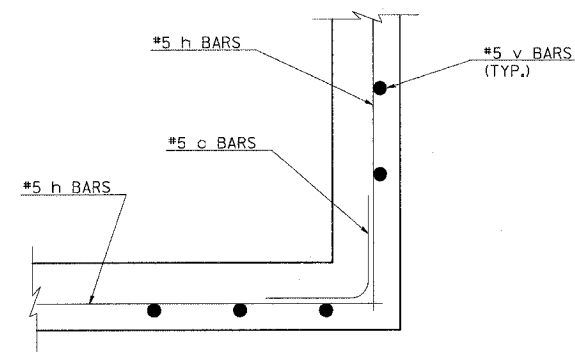

TO BE USED AT CORNER STA. 761+55

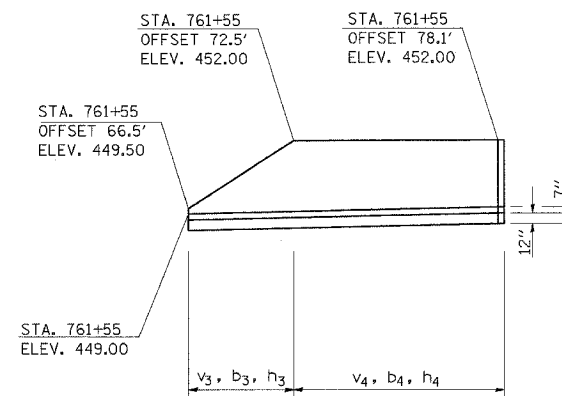

ELEVATION
RT. STA. 761+55
OFFSET 66.5' TO 78.1'

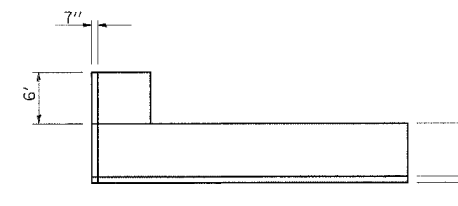

PLAN

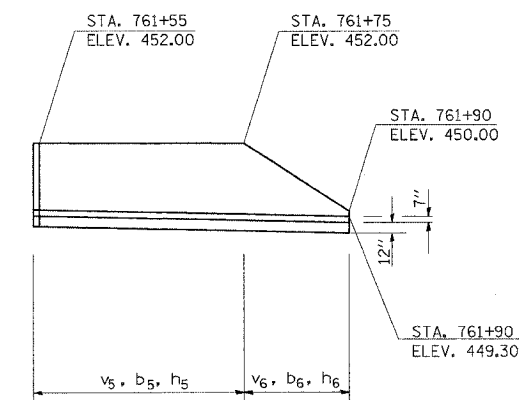

ELEVATION
RT. STA. 761+55 TO STA. 761+90

BILL OF MATERIALS

BAR	NO.	SIZE	LENGTH	SHAPE
c	11	#5	2.50'	L
v3	6	#5	2.87' AVG.	—
b3	4	#5	6.25'	L
h3	10	#5	7.08'	—
v4	6	#5	3.95' AVG.	—
b4	4	#5	6.25'	L
h4	11	#5	6.66'	—
v5	20	#5	3.90' AVG.	—
b5	14	#5	6.25'	L
h5	11	#5	21.08'	—
v6	15	#5	2.90' AVG.	—
b6	10	#5	6.25'	L
h6	10	#5	16.08'	—
REINFORCEMENT BARS			967	POUND
CONCRETE STRUCTURES			10.0	CU. YD.
PROTECTIVE COAT			1,220.0	SQ. YD.

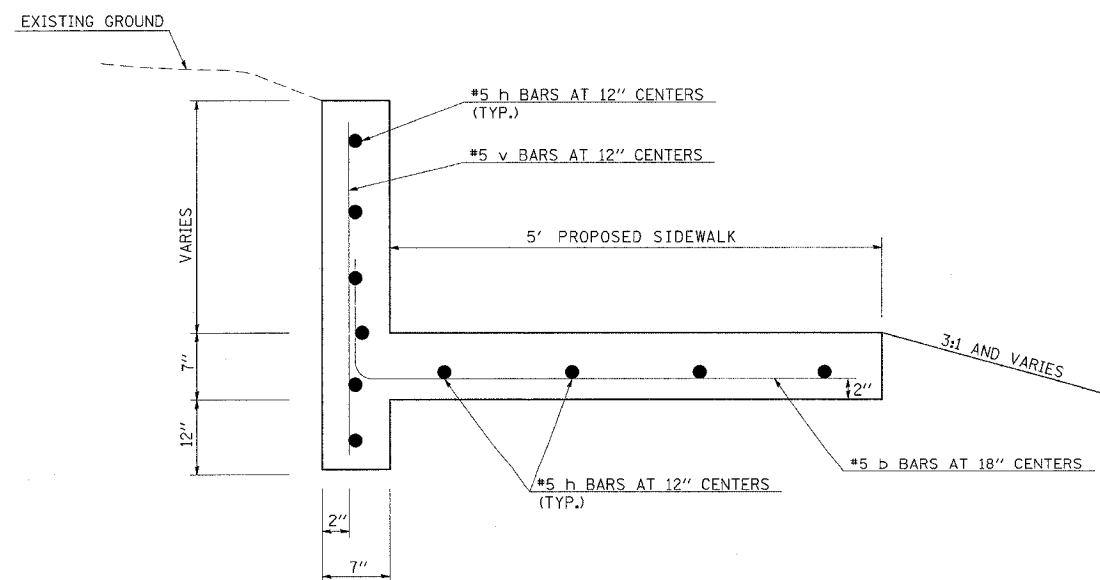

RETAINING WALL

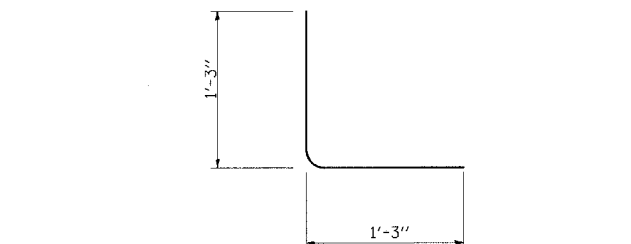

c BAR

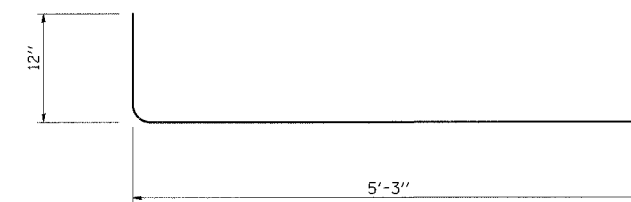

b BAR

REVISIONS		ILLINOIS DEPARTMENT OF TRANSPORTATION
NAME	DATE	
		<p>DETAIL: RETAINING WALL RT. STA. 759+15 TO STA. 761+90</p> <p>SCALE: VERT. NONE HORIZ. DATE</p> <p>DRAWN BY CNH CHECKED BY</p>

PLOT DATE = 12/7/2006
FILE NAME = \\s0128862\id13\id13p3.dgn
PLOT SCALE = 50.000000 / IN.
USER NAME = heeden

PAGES 796 + 797 NOT USED

CONTRACT NO. 98950			
F.A. RTE.	SECTION	COUNTY	TOTAL SHEET NO.
*	**	WILLIAMSON	917 798
STA.		TO STA.	
FED. ROAD DIST. NO.		ILLINOIS FED. AID PROJECT	
		* I-57, & OLD IL 13 (FAU 9629)	
		** (X1-6-2)VB-2,(X1-6)HBK-2	

DETAIL OF PRECAST CONCRETE BOX CULVERT SECTION

(WITH LESS THAN 2 FEET OF COVER AASHTO DESIGNATION M273)
DESIGN LOADING: HS-20-44

GENERAL NOTES

SHOP PLANS FOR THE REINFORCEMENT SHALL BE SUBMITTED IN ACCORDANCE WITH THE REQUIREMENTS OF ARTICLE 504.04 OF THE STANDARD SPECIFICATIONS.

MINIMUM CONCRETE STRENGTH SHALL BE 5000 PSI AFTER 28 DAYS.

THE JOINTS OF THE PRECAST BOX SECTIONS SHALL BE SEALED WITH MASTIC IN ACCORDANCE WITH ARTICLE 1055 OF THE STANDARD SPECIFICATIONS FOR ROAD AND BRIDGE CONSTRUCTION.

LIFTING HOLES SHALL BE FILLED WITH CONCRETE PLUGS AND MASTIC AFTER THE BOX SECTIONS ARE IN PLACE.

THE TERMS AS1, AS2, ETC. DENOTE THE REQUIRED STEEL AREAS FOR REINFORCEMENT AS SPECIFIED IN AASHTO M273.

REINFORCEMENT SHALL BE WELDED WIRE FABRIC CONFORMING TO ASTM SPECIFICATIONS A 185 OR A 497. LONGITUDINAL DISTRIBUTION REINFORCEMENT MAY CONSIST OF WELDED WIRE FABRIC OR DEFORMED BILLET-STEEL BARS CONFORMING TO AASHTO M-31, M-42, GRADE 60.

DRAINAGE OPENINGS SHALL BE PROVIDED IN ACCORDANCE WITH ARTICLE 503.12 OF THE STANDARD SPECIFICATIONS. LOCATION AND SPACING OF THE OPENINGS SHALL BE SHOWN ON THE SHOP DRAWINGS.

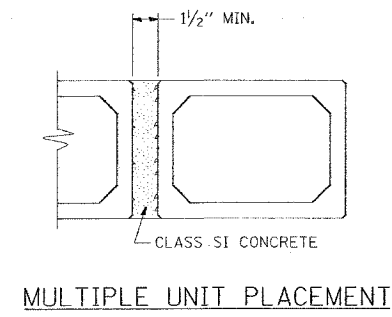

MULTIPLE UNIT PLACEMENT

DIMENSIONS & EDGE BEAM REINFORCEMENT

SPAN X RISE	DIMENSIONS (INCHES)			EDGE BEAM REINF. AREA (IN. ² /FT.)
	T _T	T _B	T _S	A _{S10}
3' X 2'	7	6	4	0.42
3' X 3'	7	6	4	0.42
4' X 2'	7 1/2	6	5	0.59
4' X 3'	7 1/2	6	5	0.59
4' X 4'	7 1/2	6	5	0.59
5' X 3'	8	7	6	0.59
5' X 4'	8	7	6	0.59
5' X 5'	8	7	6	0.59
6' X 2'	8	7	7	0.73
6' X 3'	8	7	7	0.73
6' X 4'	8	7	7	0.73
6' X 5'	8	7	7	0.73
6' X 6'	8	7	7	0.73
7' X 4'	8	8	8	0.85
7' X 5'	8	8	8	0.85
7' X 6'	8	8	8	0.85
7' X 7'	8	8	8	0.85
8' X 4'	8	8	8	1.00
8' X 5'	8	8	8	1.00
8' X 6'	8	8	8	1.00
8' X 7'	8	8	8	1.00
8' X 8'	8	8	8	1.00
9' X 5'	9	9	9	1.00
9' X 6'	9	9	9	1.00
9' X 7'	9	9	9	1.00
9' X 8'	9	9	9	1.00
9' X 9'	9	9	9	1.00
10' X 5'	10	10	10	0.89
10' X 6'	10	10	10	0.89
10' X 7'	10	10	10	0.89
10' X 8'	10	10	10	0.89
10' X 9'	10	10	10	0.89
10' X 10'	10	10	10	0.89
11' X 4'	11	11	11	0.89
11' X 6'	11	11	11	0.89
11' X 8'	11	11	11	0.89
11' X 10'	11	11	11	0.89
11' X 11'	11	11	11	0.89
12' X 4'	12	12	12	0.89
12' X 6'	12	12	12	0.89
12' X 8'	12	12	12	0.89
12' X 10'	12	12	12	0.89
12' X 12'	12	12	12	0.89

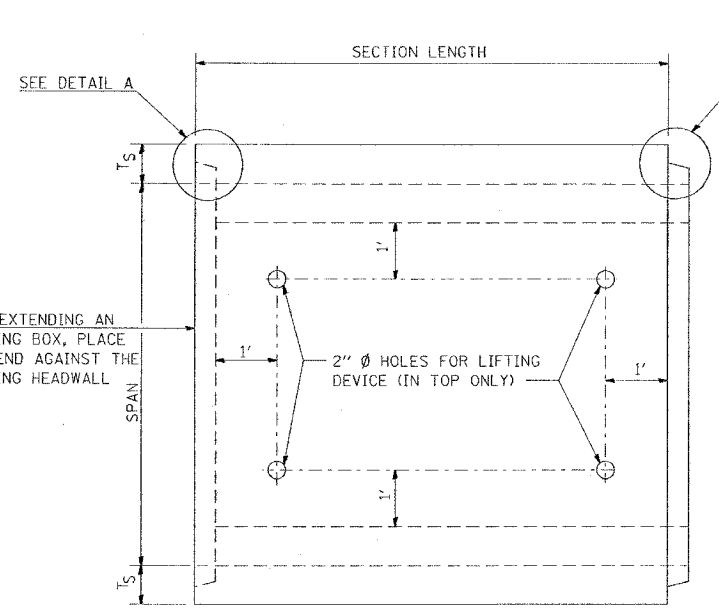

PLAN

LOCATION OF LIFTING HOLES MAY BE VARIED AS NEEDED TO CLEAR REINFORCEMENT.

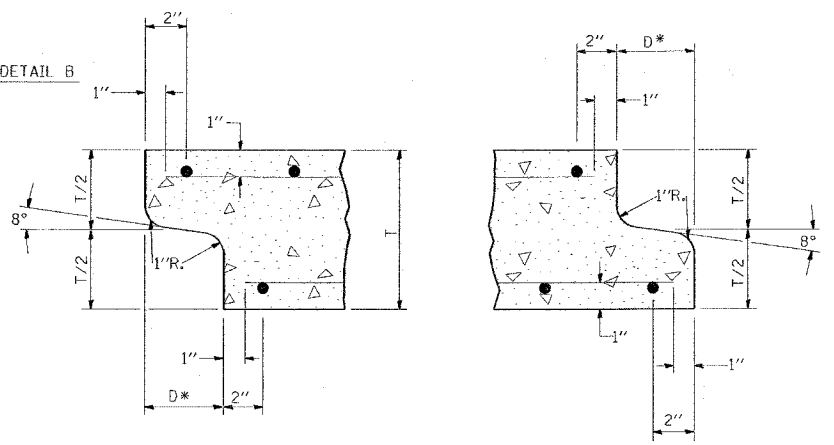

DETAIL A

(TYP. INLET END)

DETAIL B

(TYP. OUTLET END)

NOTE: INLET AND OUTLET ENDS SHALL BE COMPATIBLE.
* THE D DIMENSION SHALL CONFORM TO THE MANUFACTURER'S STANDARDS.

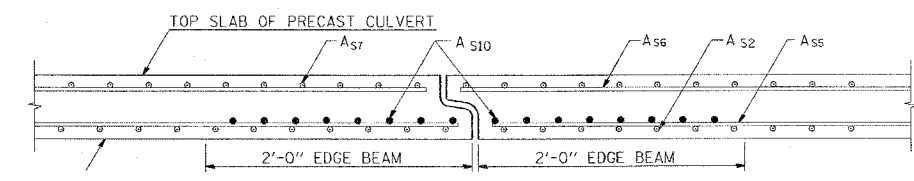

DETAIL OF EDGE BEAM

NOTE: THE A_{S10} REINFORCEMENT SHALL BE THE SAME LENGTH AS THE A_{S2}.

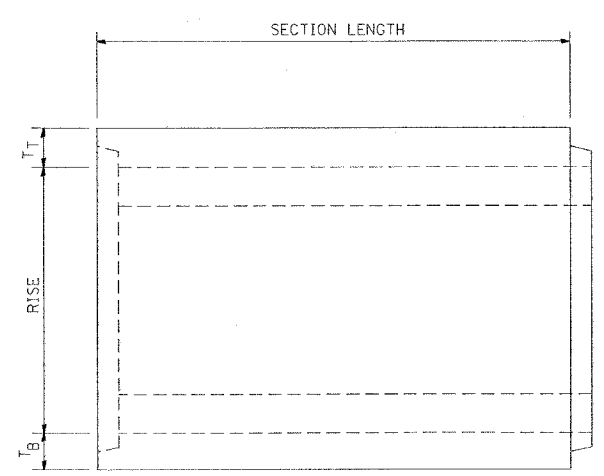

ELEVATION

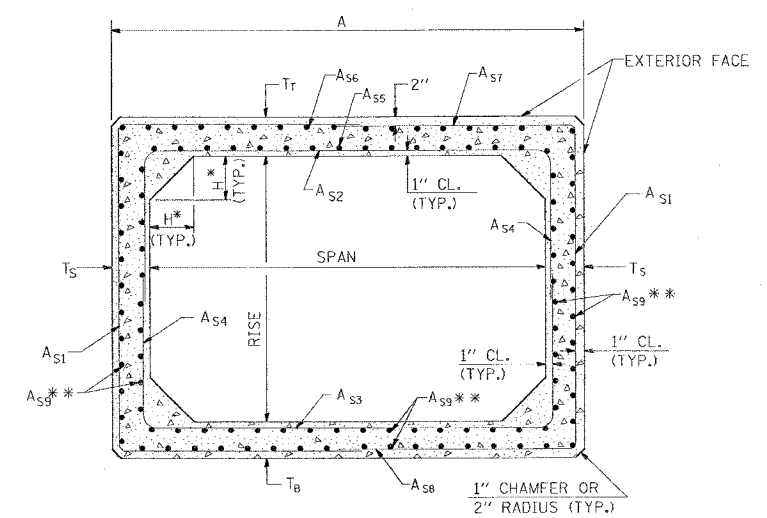

CROSS SECTION

* THE HAUNCH DIMENSION, H, IS EQUAL TO THE WALL THICKNESS, T_S.
** THE AREA OF A_{S9} REINFORCEMENT SHALL BE A MINIMUM OF 0.12 SQ. IN./FT.

REVISIONS	
NAME	DATE

ILLINOIS DEPARTMENT OF TRANSPORTATION

DETAIL:
PRECAST CONCRETE BOX CULVERT SECTION WITH LESS THAN 2' OF COVER

SCALE: VERT. NONE
HORIZ. DATE

DRAWN BY CNH
CHECKED BY

REVISIONS			
NO.	DATE	BY	REASON
1	9-8-89	REVISOR	12-17-01
2	3-27-90	REVISOR	
3	3-11-92	REVISOR	
4	8-16-94	REVISOR	

STD. 9-49

PLOT DATE: 10/13/2006
FILE NAME: c:\p\proj\mca\cpr2002\old\13\old\93.dgn
PLOT SCALE: 1/8" = 1'-0"
USER NAME: f. hudson

CONTRACT NO. 98950

F.A. RTE.	SECTION	COUNTY	TOTAL SHEETS	SHEET NO.
*	**	WILLIAMSON	917	799
STA.		TO STA.		
FED. ROAD DIST. NO.		ILLINOIS	FED. AID PROJECT	
* I-57, & OLD IL 13 (FAU 9629)				
** (X1-6-2)VB-2,(X1-6)HBK-2				



BITUMINOUS SURFACE REMOVAL (VARIABLE DEPTH)
BEFORE PLACING FINAL LIFT TO MAKE GORE
REGION. EDGE OF PAVEMENT MILLING IS
0 THEN GOES TO THE DEPTH SHOWN.

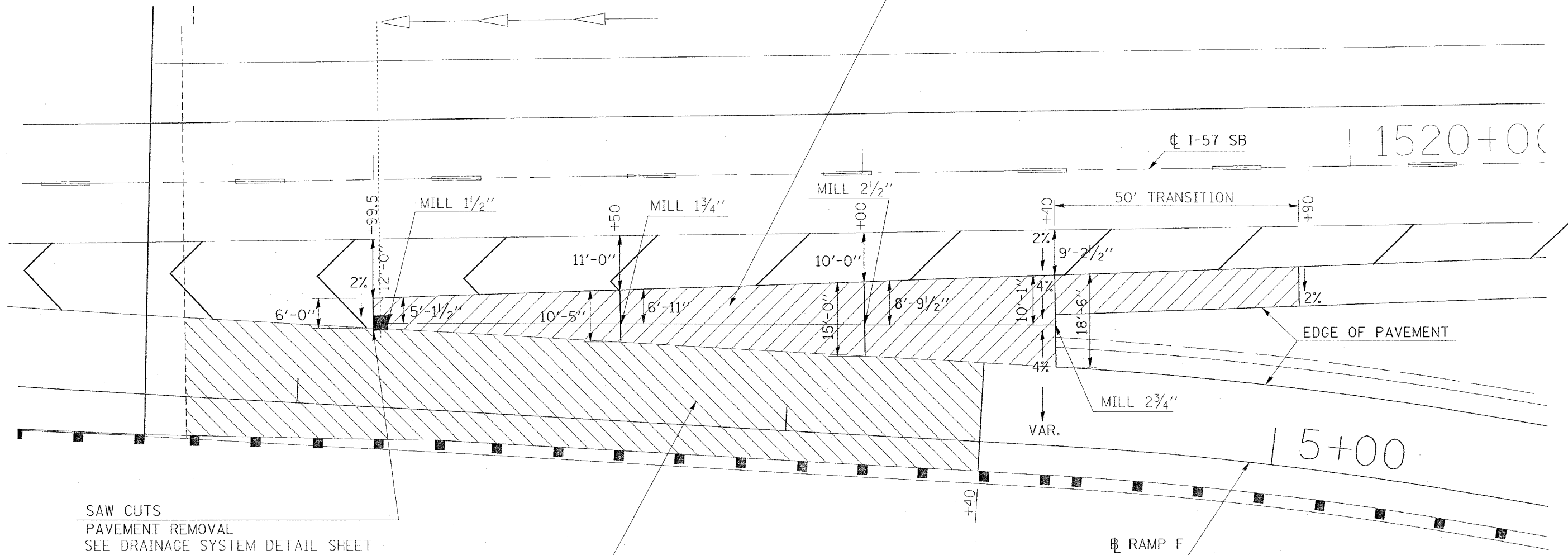

SAW CUTS
PAVEMENT REMOVAL
SEE DRAINAGE SYSTEM DETAIL SHEET --

BITUMINOUS SURFACE REMOVAL (VARIABLE DEPTH)
BEFORE PLACING SURFACE COURSE LIFT TO
CORRECT PROFILE

REVISIONS	
NAME	DATE

ILLINOIS DEPARTMENT OF TRANSPORTATION

MILLING DETAIL RAMP F

SCALE: VERT. 10
HORIZ.

DRAWN BY CNH
CHECKED BY

P. DATE = 10/14/2006
 FILE NAME = c:\vpro\work\98950\13\13\13\13.dgn
 PLOT SCALE = 10.0000 "/ IN.
 USER NAME = hnsdm

CONTRACT NO. 98950

F.A. RTE.	SECTION	COUNTY	TOTAL SHEETS	SHEET NO.
*	*	WILLIAMSON	917	800
STA.			TO STA.	
FED. ROAD DIST. NO.	ILLINOIS	FED. AID PROJECT		
* I-57, & OLD IL 13 (FAU 9629)				
** (X1-6-2)VB-2,(X1-6)HBK-2				

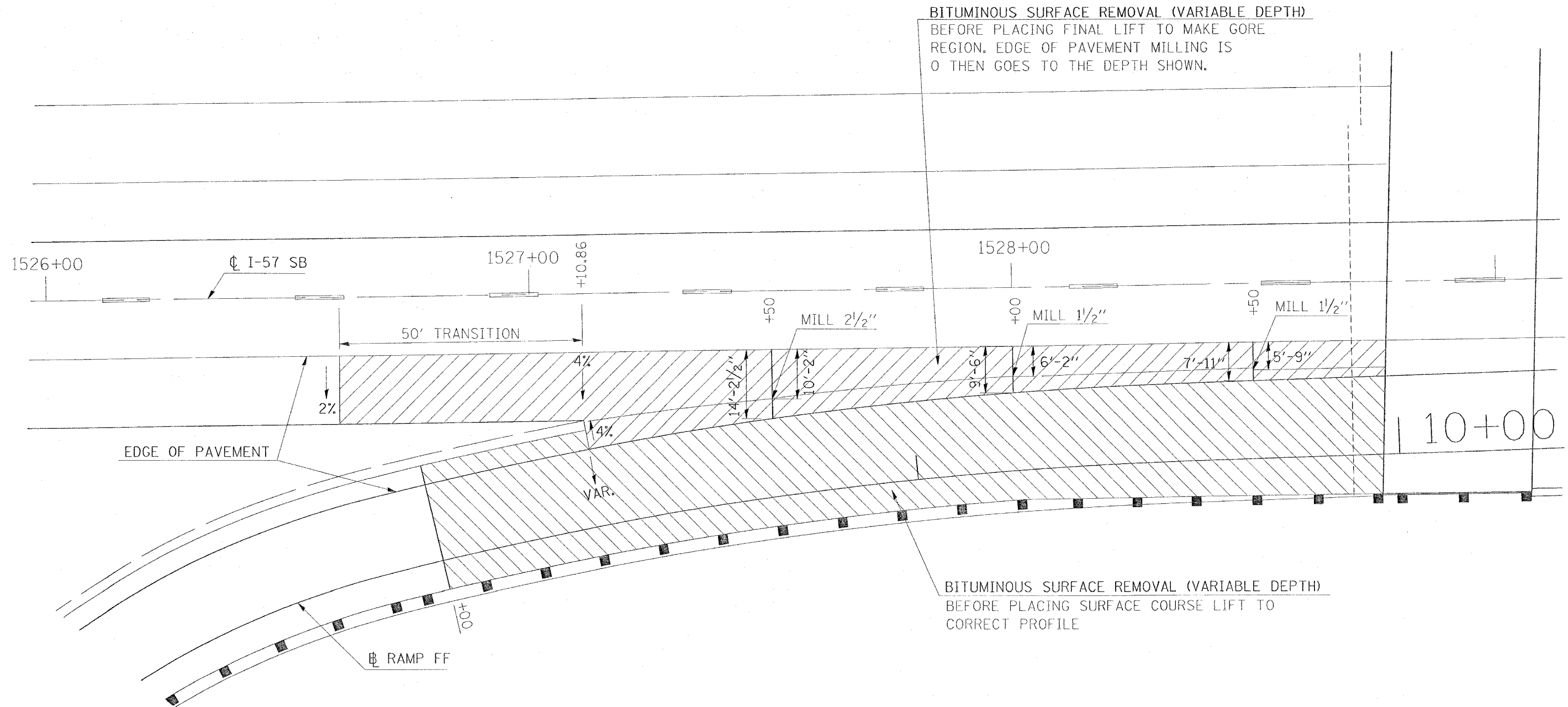

REVISIONS	
NAME	DATE

ILLINOIS DEPARTMENT OF TRANSPORTATION
MILLING DETAIL RAMP FF

SCALE: VERT. 10
 HORIZ. 1" = 10'
 DATE: _____ DRAWN BY CNH
 CHECKED BY _____

DATE = 10/14/2006
 USER = hns
 PLOT SCALE = 10.0000
 USER NAME = hns