

Notes:

All exposed edges shall have a 3/4" chamfer

Reinforcement bars designated (E) shall be epoxy coated.

Plan dimensions and details relative to existing plans are subject to nominal construction variations. The Contractor shall field verify existing dimensions and details affecting new construction and make necessary approved adjustments prior to construction or ordering of materials. Such variations shall not be cause for additional compensation for a change in scope of the work, however, the Contractor will be paid for the quantity actually furnished based at the unit price bid for the work

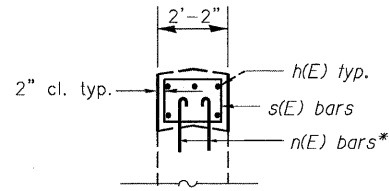

SECTION A-A

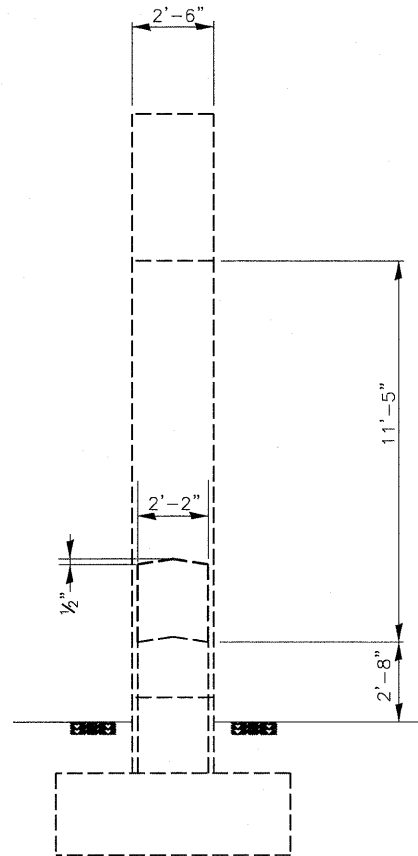

END VIEW

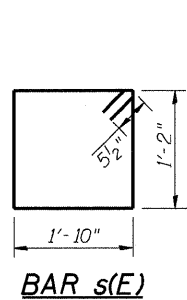

BAR s(E)

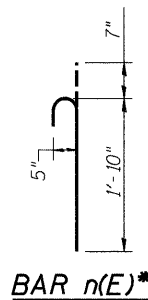

BAR n(E)\*

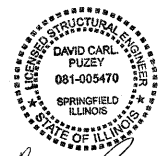

*David Carl Puze*  
Expires 11/30/12

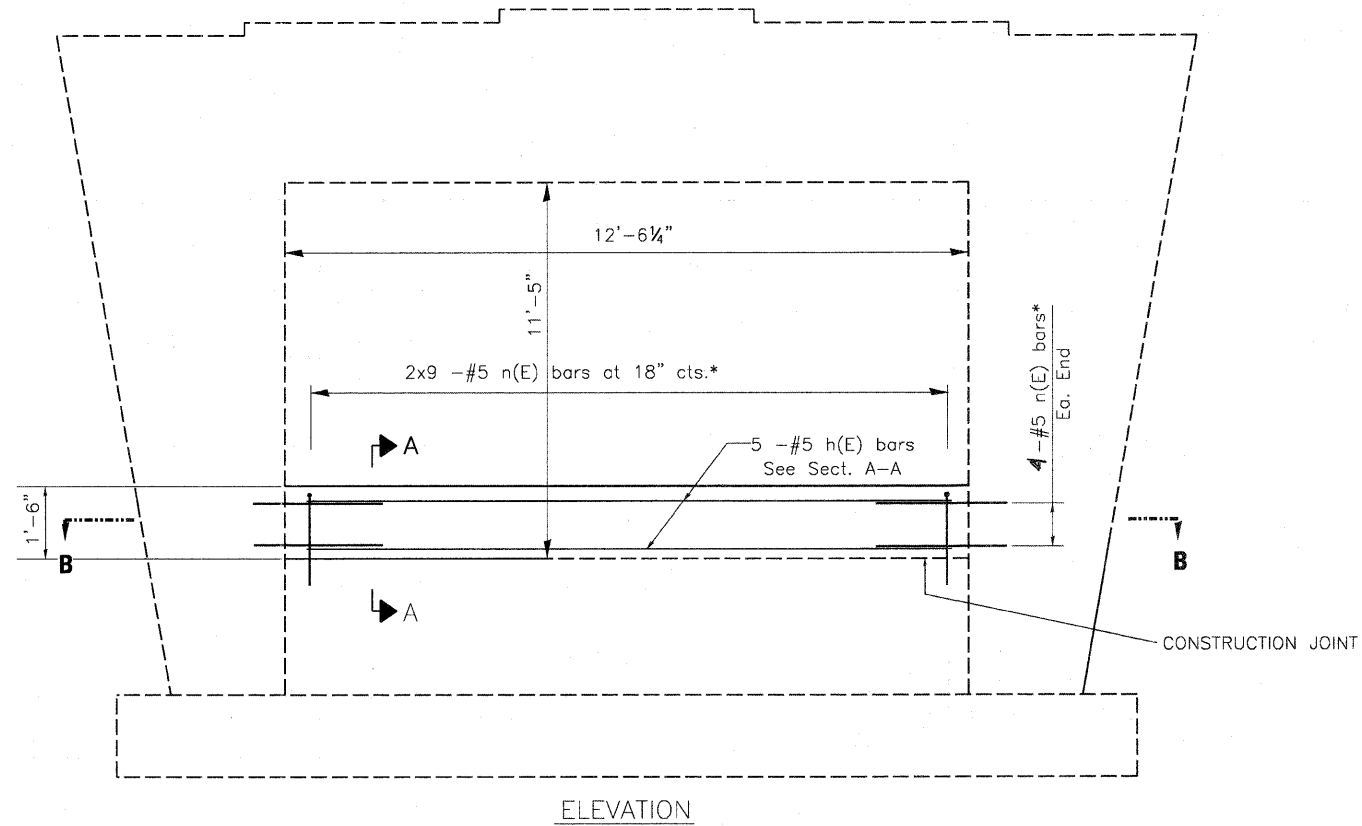

ELEVATION

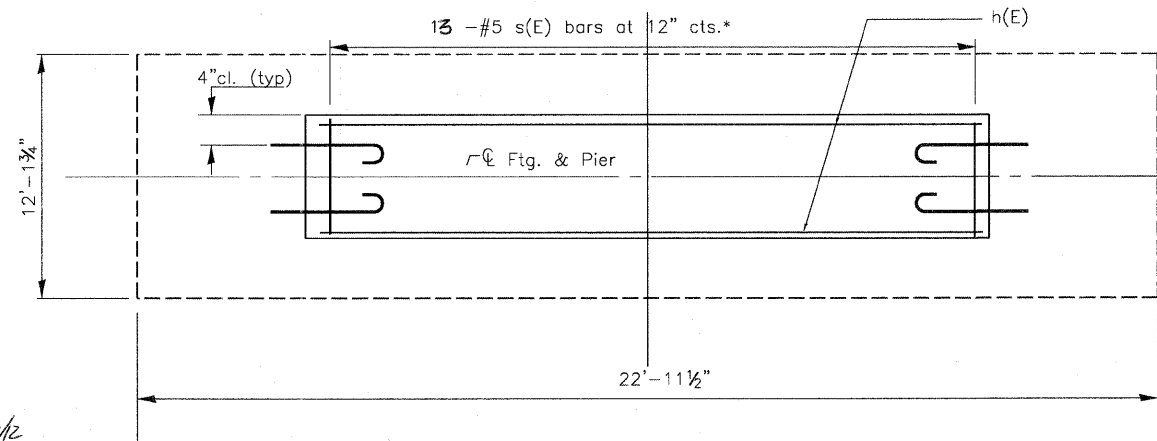

SECTION B-B

\*Drill & Epoxy Grout bars in 9" min. drilled holes according to Section 584 of Std. Spec. Cost included with Reinforcement Bars, Epoxy Coated

BILL OF MATERIAL

Bar	No.	Size	Length	Shape
h(E)	5	#5	12'-2"	—
n(E)	26	#5	2'-5"	⌋
s(E)	13	#5	6'-11"	⌋
Reinforcement Bars, Epoxy Coated			POUND	223
Concrete Structures			CU YD	1.5

MEDIAN PIER

TERRA COTTA ROAD OVER FAI 80  
SEC. (50-2, 4)RS-5 & (50-3)RS-6  
LASALLE COUNTY  
S.N. 050-0222

FILE NAME =	USER NAME = #USER#	DESIGNED -	REVISED -	STATE OF ILLINOIS DEPARTMENT OF TRANSPORTATION	CRASH WALL EXTENSION DETAIL SN 050-0222	F.A.I. RTE.	SECTION	COUNTY	TOTAL SHEETS	SHEET NO.	
#FILE#		DRAWN -	REVISED -			80	(50-2, 4)RS-5 & (50-3)RS-6	LASALLE	109	82	
	PLOT SCALE = #SCALE#	CHECKED -	REVISED -			CONTRACT NO. 66A48					
	PLOT DATE = #DATE#	DATE -	REVISED -			ILLINOIS FED. AID PROJECT					