

WING ELEVATION

*ORDER v₁(E) BARS IN FULL LENGTH AND CUT IN FIELD TO FIT.

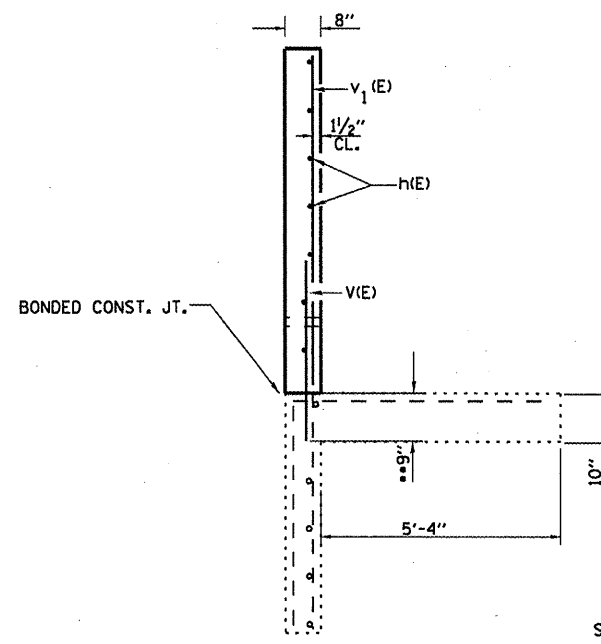

SECTION A-A

** DRILL & GROUT v₁(E) BARS INTO EXISTING CONCRETE FOOTING ACCORDING TO SECTION 584 OF THE STANDARD SPEC.

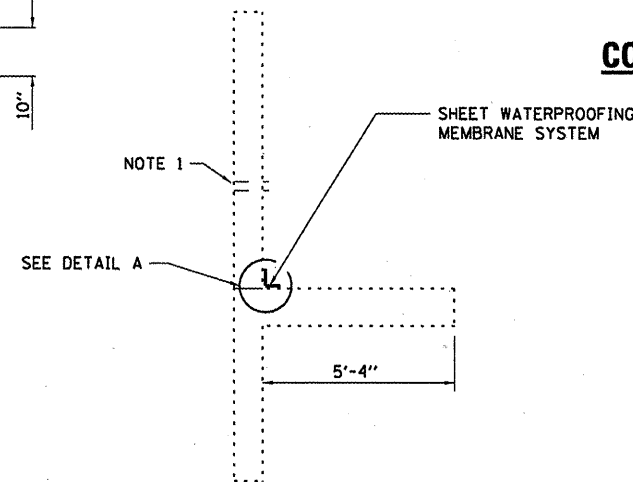

SECTION A-A

SHEET WATERPROOFING MEMBRANE SYSTEM

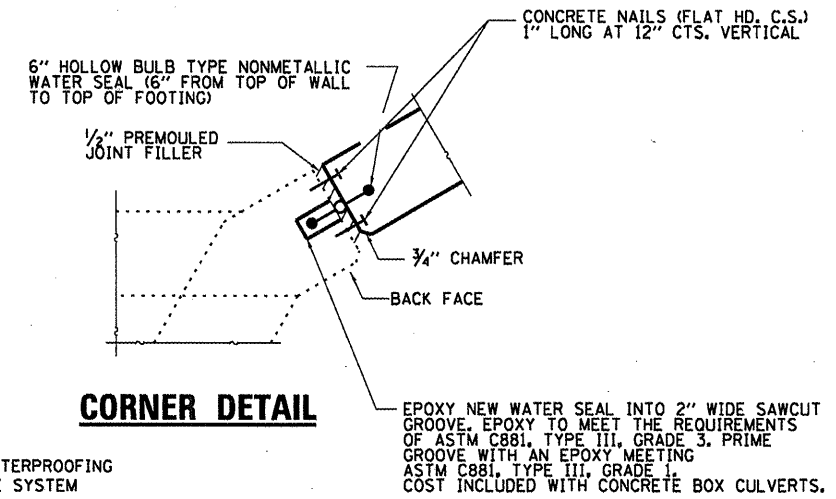

CORNER DETAIL

EPOXY NEW WATER SEAL INTO 2" WIDE SAWCUT GROOVE, EPOXY TO MEET THE REQUIREMENTS OF ASTM C881, TYPE III, GRADE 3, PRIME GROOVE WITH AN EPOXY MEETING ASTM C881, TYPE III, GRADE 1. COST INCLUDED WITH CONCRETE BOX CULVERTS.

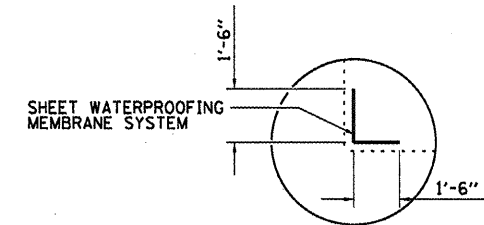

DETAIL A

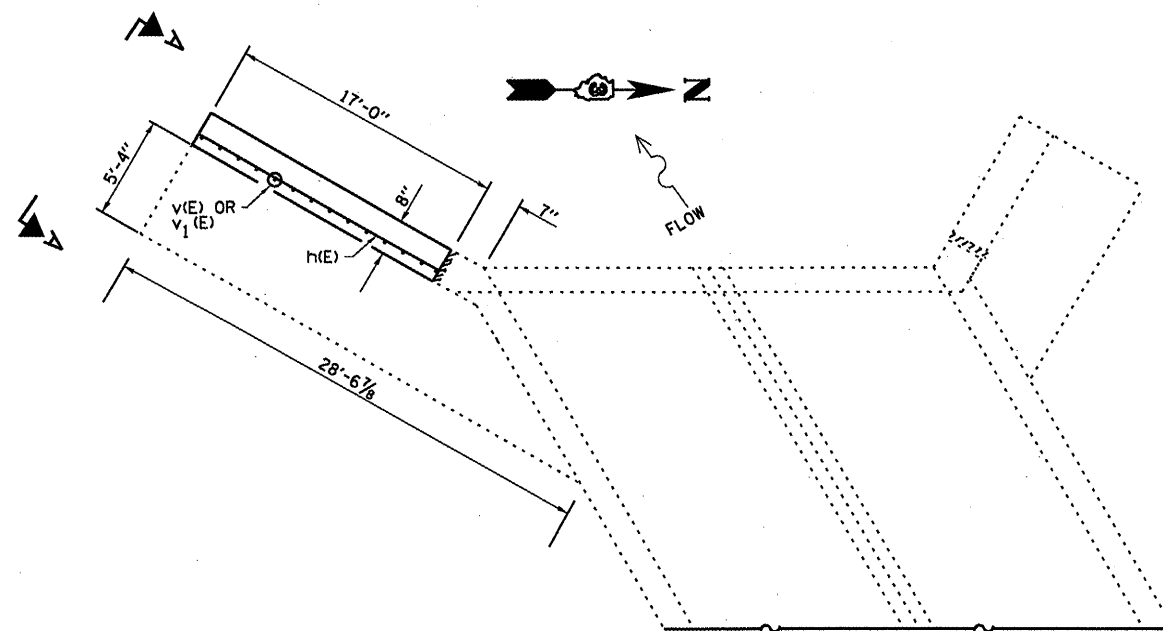

PARTIAL PLAN

BILL OF MATERIAL

Bar	No.	Size	Length	Shape
h(E)	7	#5	16'-9"	—
v(E)	23	#6	3'-0"	—
v ₁ (E)	23	#4	8'-2"	—
Concrete Box Culverts			Cu. Yd.	2.8
Reinforcement Bars			Pound	351
Sheet Waterproofing Membrane System			Sq. Yd.	6.0

FILE NAME =	USER NAME = patel.j	DESIGNED - YOGESH PATEL	REVISED -
c:\pwork\puidot\patel.j\02265509\036642-sheets.dgn		DRAWN - YOGESH PATEL	REVISED -
		CHECKED - RON WOODSHANK	REVISED -
		DATE -	REVISED -

STATE OF ILLINOIS
DEPARTMENT OF TRANSPORTATION

**RECONSTRUCTION DETAILS
FOR LOCATION 1: SN 053-2012**

SCALE: SHEET NO. 5 OF 5 SHEETS STA. TO STA.

F.A.P. RTE. VAR.	SECTION VARIOUS	COUNTY VARIOUS	TOTAL SHEETS 40	SHEET NO. 11
			CONTRACT NO. 66B42	
ILLINOIS FED. AID PROJECT				