

WEST APPROACH
Showing Dimensions
(East Approach Similar)

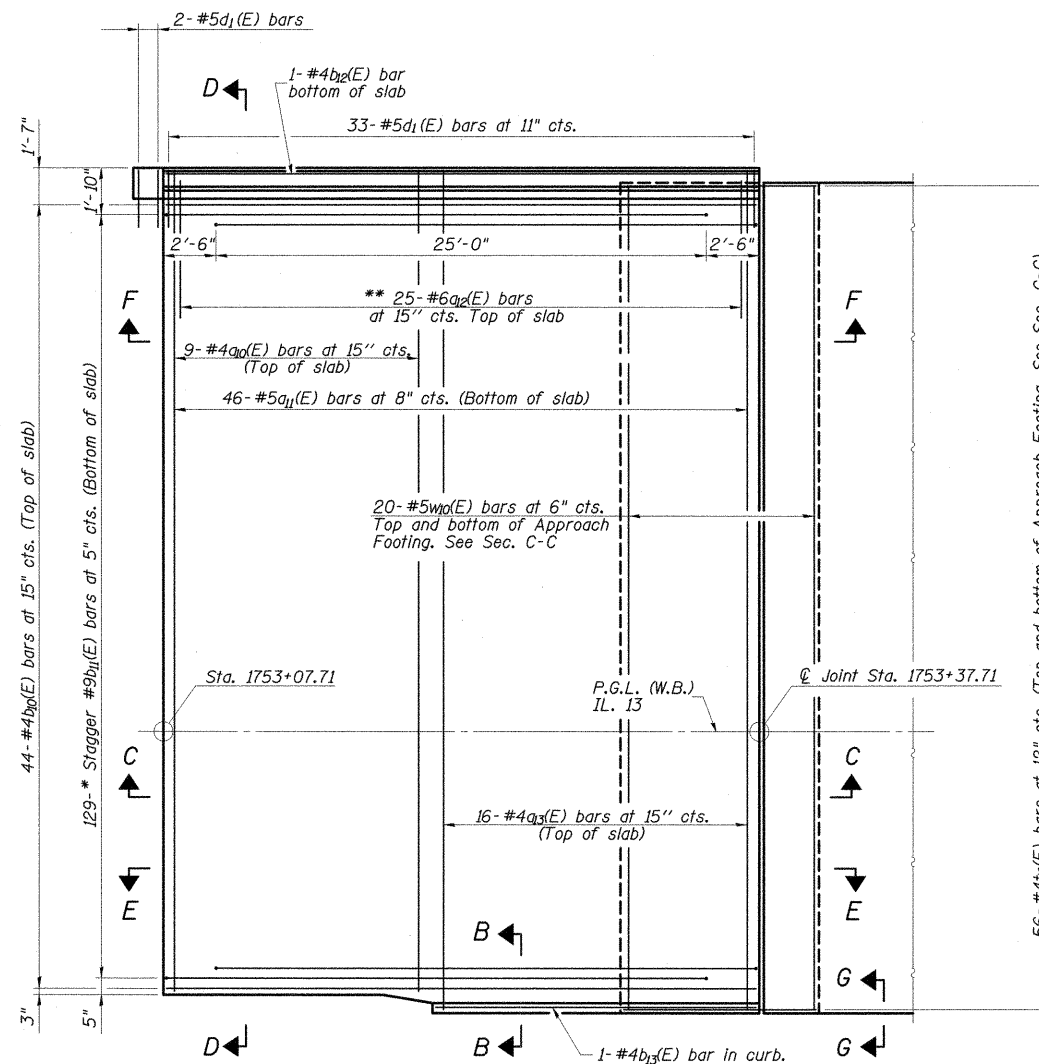

EAST APPROACH
Showing Reinforcement
(West Approach Similar)

PLAN
(S.N. 100-0095 shown)
(S.N. 100-0096 similar)

- * Tilt #9b1(E) bars as required to maintain clearance.
- ** Space between a(E) bars, typ. ea. parapet.
- *** Closed cell joint filler according to Article 1051.08 of the Std. Specifications: full depth of slab, full length of parapet.

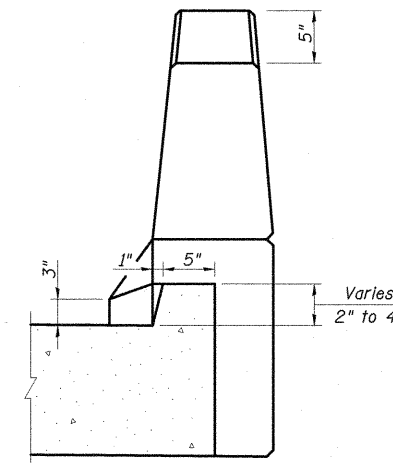

VIEW B-B

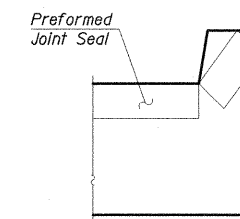

VIEW G-G

Angle Preformed Joint Seal at 45° at curbs when req'd for drainage.

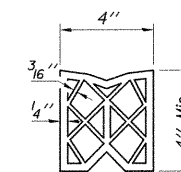

PREFORMED JOINT SEAL

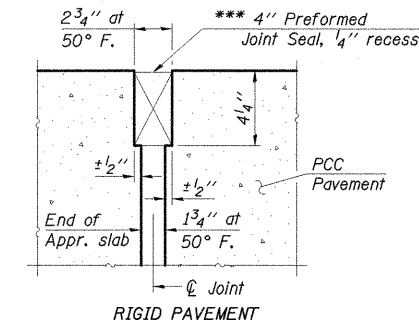

DETAIL A

*** Cost included with Concrete Superstructure.

NOTES:

1. See sheet 16 of 32 for Sections C-C & D-D and Views E-E & F-F.
2. Order a2(E), a1(E), b2(E), and b1(E) bars full length. Cut in the field to fit Type C Inlet Box, Standard 609006 (Special).

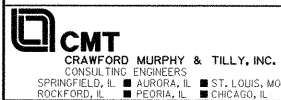

FILE NAME =	USER NAME =	DESIGNED - SF	REVISED -
I:\dot\0906603\draw\cadd\sheet\structure\al\plans\marathon dr bridge\marathon final		CHECKED - APPROACH SLAB DETAILS 1.dgn	REVISED -
	PLOT SCALE =	DRAWN - GLD	REVISED -
	PLOT DATE =	CHECKED - SF	REVISED -

STATE OF ILLINOIS
DEPARTMENT OF TRANSPORTATION

APPROACH SLAB DETAILS 1
STRUCTURE NO. 100-0095 (W.B.) & 100-0096 (E.B.)

SHEET NO. 15 OF 32 SHEETS

F.A.P. RTE.	SECTION	COUNTY	TOTAL SHEETS	SHEET NO.
331	(1X-1) VB-1, B-1, N-4, R-3	WILLIAMSON	367	222
			CONTRACT NO. 98859	
ILLINOIS FED. AID PROJECT				