

STATE OF ILLINOIS
DEPARTMENT OF TRANSPORTATION

ROUTE NO. FAP 347	SECTION	COUNTY Cook	TOTAL SHEETS 17	SHEET NO. 9	SHEET NO. 2 5 SHEETS
FED. ROAD DIST. NO. 7		ILLINOIS		FED. AID PROJECT	

Contract Number: 62956

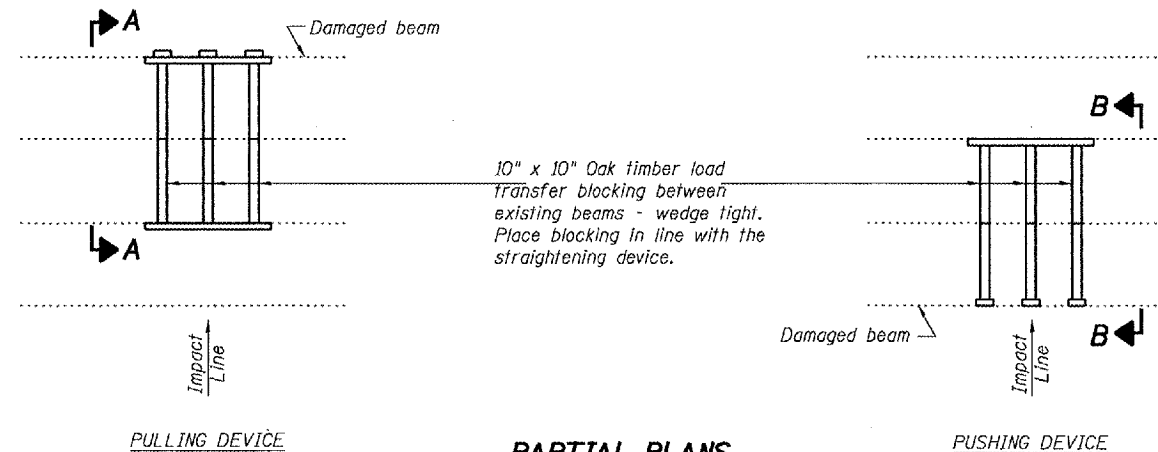

PARTIAL PLANS
SUGGESTED BEAM STRAIGHTENING METHODS

Straightening force shall be maintained on all load transfer blocking during beam straightening.

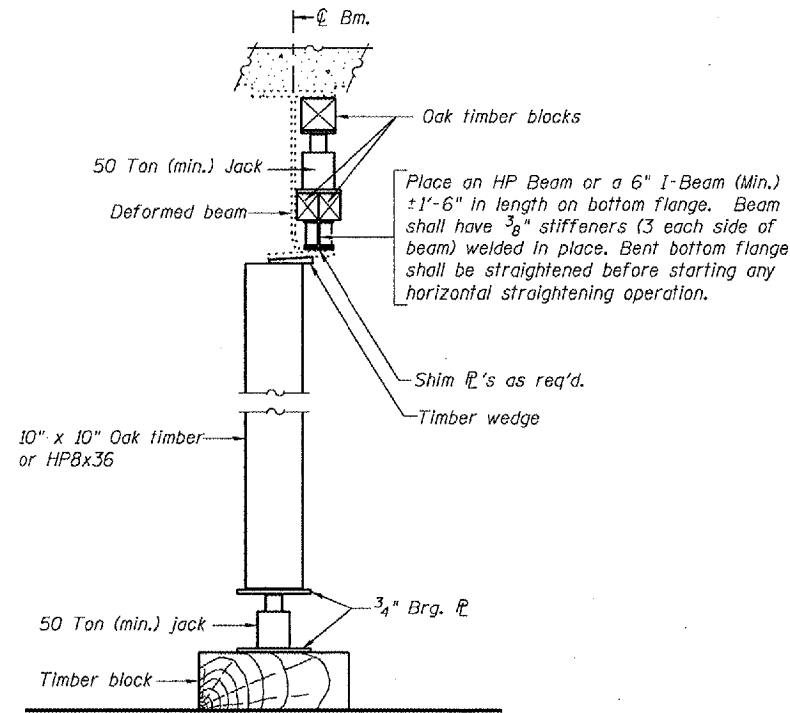

SUGGESTED VERTICAL STRAIGHTENING DETAIL
(To correct flange rotation.)

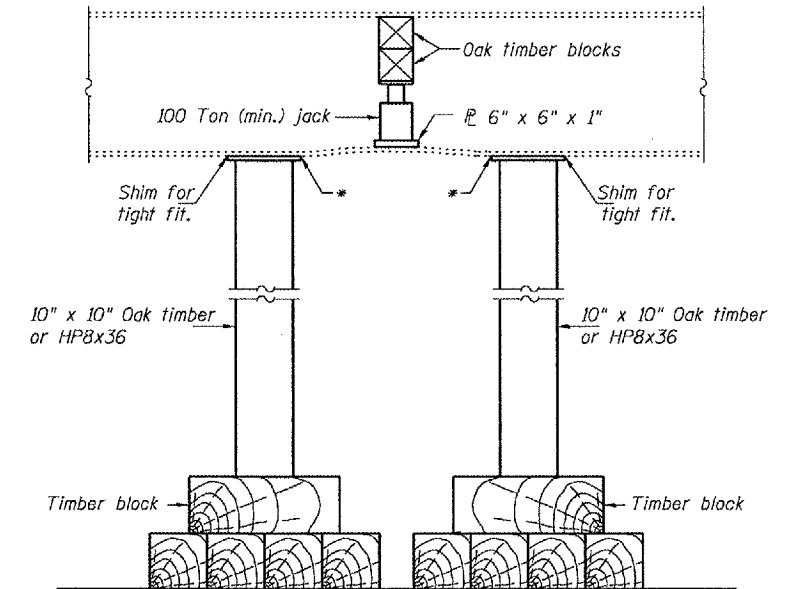

SUGGESTED VERTICAL STRAIGHTENING DETAIL
(To correct localized vertical flange deformations.)

* Edge of plate shall line up with edge of deformation.

Note:
Braces and jack assembly shall be placed on same side of web.
Bent bottom flange shall be straightened before starting any horizontal straightening operations.

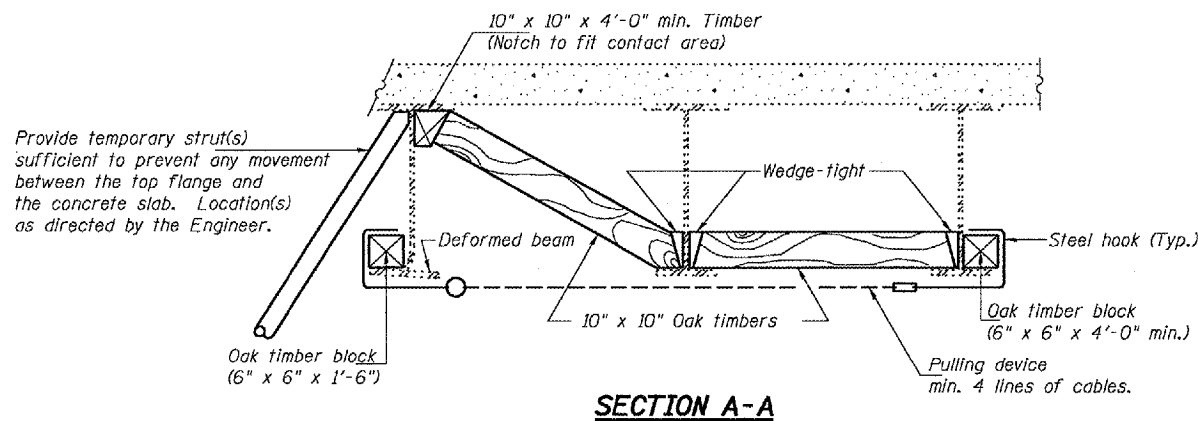

SECTION A-A

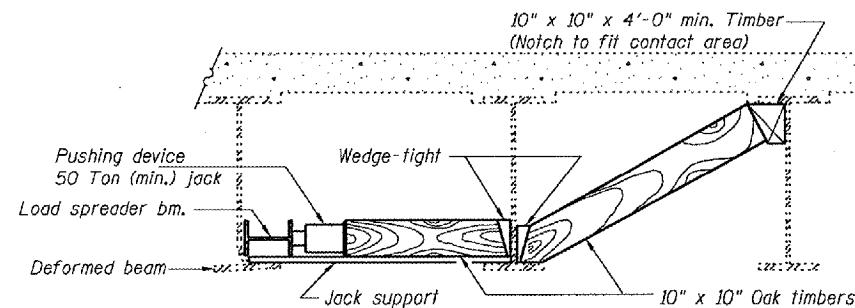

SECTION B-B

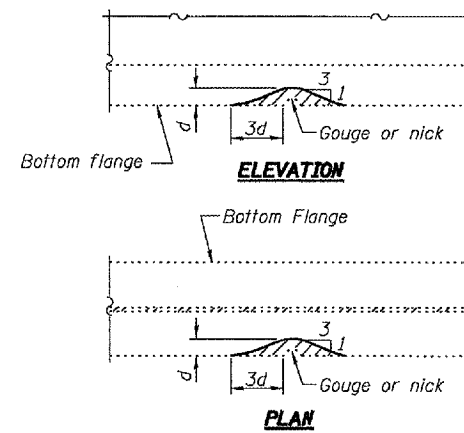

GRINDING DETAIL

Grind existing nicks, gouges and shallow cracks in the damaged beams as detailed. Ground surfaces shall be inspected for cracks using magnetic particle testing prior to initiating any beam straightening operations. Any cracks that cannot be removed by grinding approximately 1/4" deep shall be identified and reported to the Bureau of Bridges and Structures for further disposition. Ground surfaces shall be spot cleaned and painted with an aluminum epoxy mastic primer followed by a finish coat to match the color of the existing beam. Cost of grinding, testing and spot painting included with Beam Straightening.

EXISTING DEFORMATION TO BE STRAIGHTENED

(Looking West)
(Approximate max. deflections)
Deflected length of beam to be straightened is approximately 7'-6".

BEAM STRAIGHTENING DETAILS

F.A.I. RT. 90/94
COOK COUNTY
SN 016-0478

DESIGNED	A.T.H.
CHECKED	S.J.B.
DRAWN	Drew Christopher
CHECKED	A.T.H. S.J.B.

January 18, 2006

EXAMINED *John A. Morris*
ENGINEER OF STRUCTURAL SERVICES

PASSED *Ralph E. Anderson*
ENGINEER OF BRIDGES AND STRUCTURES

REP-1 1-14-2005