

STATE OF ILLINOIS
DEPARTMENT OF TRANSPORTATION

F.A.I. RTE.	SECTION	COUNTY	TOTAL SHEETS	SHEET NO.
80	32-3HBR-1	GRUNDY	88	44
STA.		TO STA.		
FED. ROAD DIST. NO.		ILLINOIS FED. AID PROJECT		

SHEET NO. B17
OF 35 SHEETS

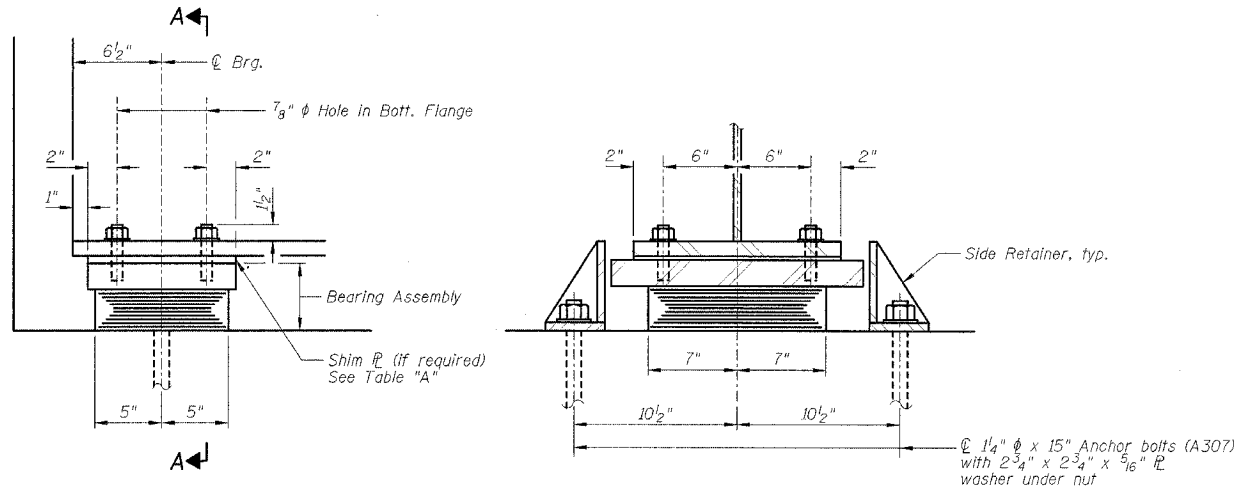

ELEVATION AT ABUT.

SECTION A-A

TYPE I ELASTOMERIC EXP. BRG.

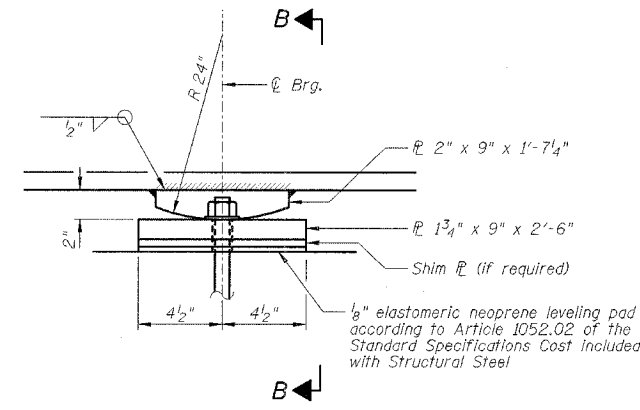

ELEVATION AT PIER

FIXED BEARING

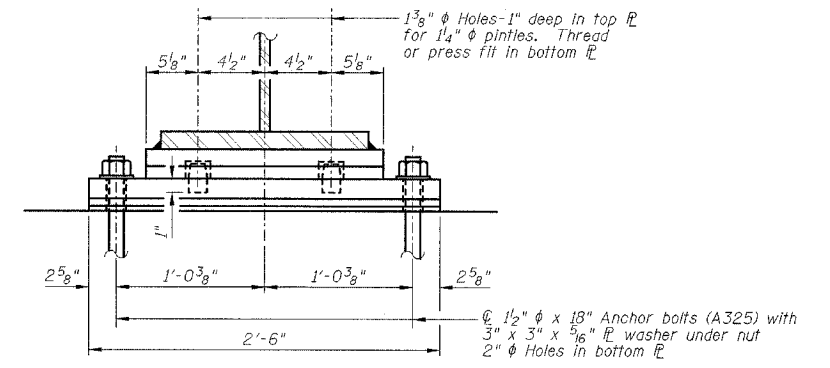

SECTION B-B

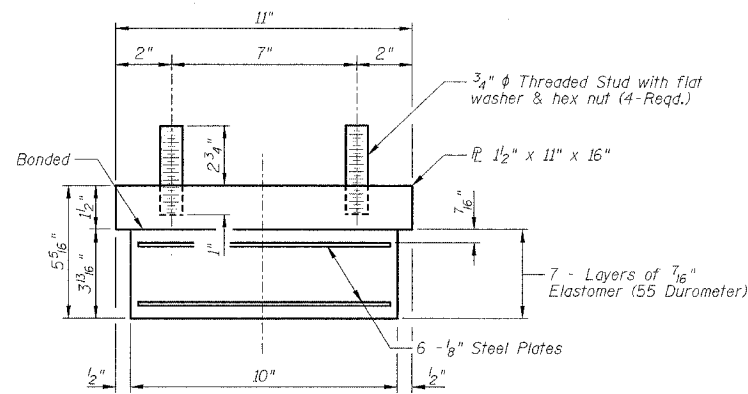

BEARING ASSEMBLY

Note: Shim plates shall not be placed under Bearing Assembly.

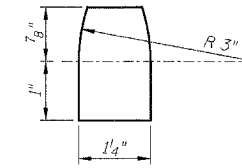

PINTLE

TABLE "A"

Location/Beam	Shim Thickness
North Abutment/Beam 4	1/2"
South Abutment/Beam 3	1/2"

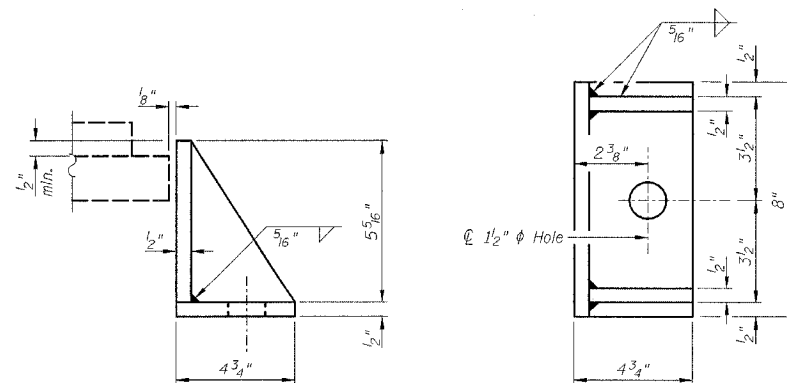

SIDE RETAINER

Equivalent rolled angle with stiffeners will be allowed in lieu of welded plates. Weight included with Structural Steel.

NOTES:

- All pier and abutment bearing plates and pintles shall be AASHTO M270 Gr50.
- All side retainer plates shall be AASHTO M270 Gr36.
- See Sheet B18 for Anchor Bolt Installation.

REVISIONS		ILLINOIS DEPARTMENT OF TRANSPORTATION BEARING DETAILS F.A.I. 80 (I-80) F.A.U. 5974 (ASHLEY ROAD) OVER I-80 SECTION 32-3HBR-1 GRUNDY COUNTY STATION 110+00.00 STRUCTURE NO. 032-0113
NAME	DATE	
		DESIGNED BY: JML DATE: 09/09/05
		DRAWN BY: DJM CHECKED BY: MSW