

REL.	SECTION	COUNTY	TOTAL SHEETS	SHEET NO.
*	LAWRENCE	10	6	

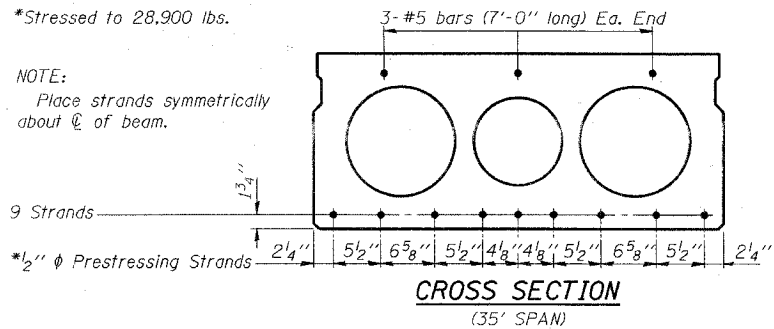

DIMENSION 'C'

Skew Angle 'D'	0°	5°	10°	15°	20°	25°	30°
Dimension 'C' (Inches)	0	4 1/4	8 1/2	12 7/8	17 1/2	22 3/8	27 3/4

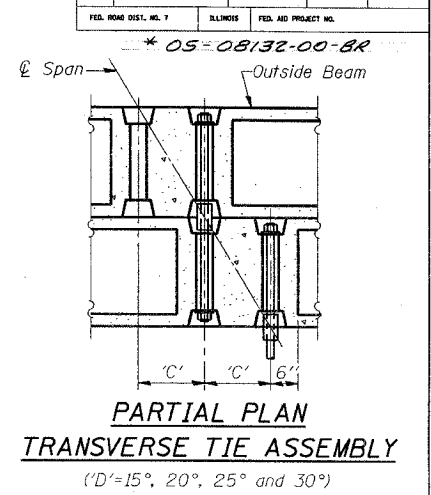
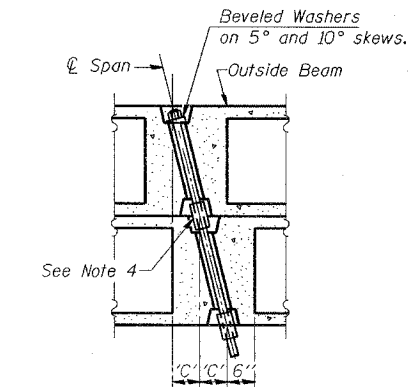
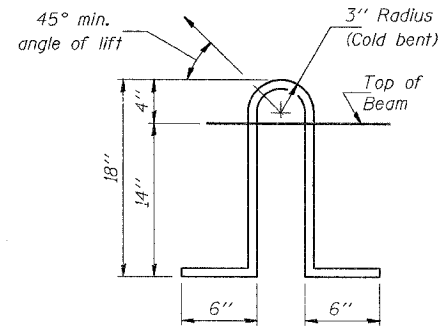
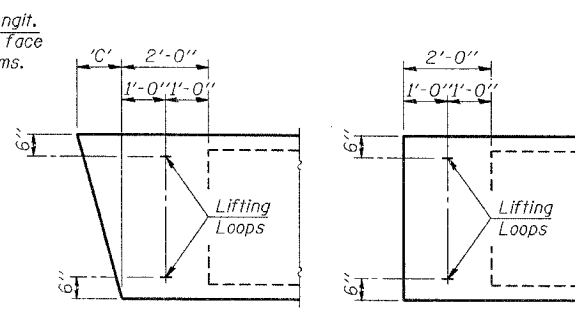
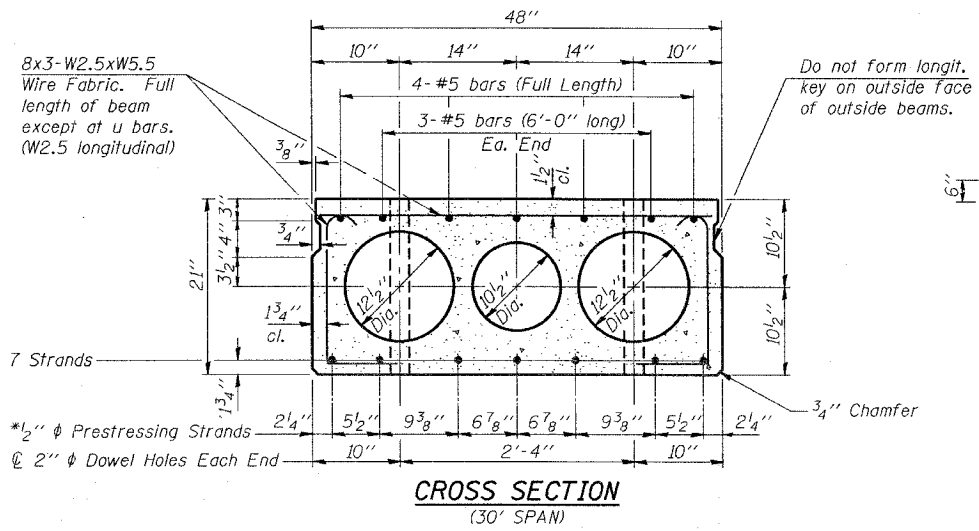
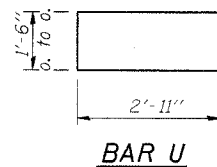
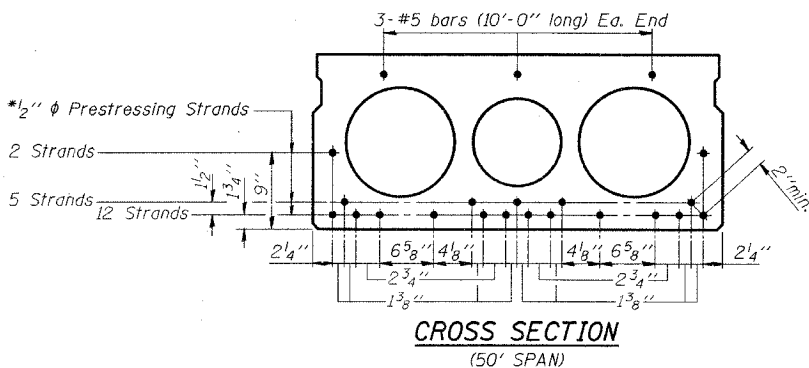
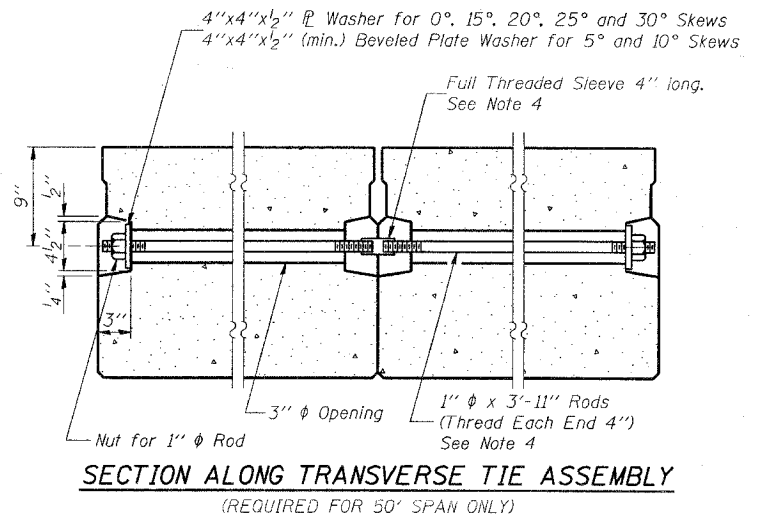
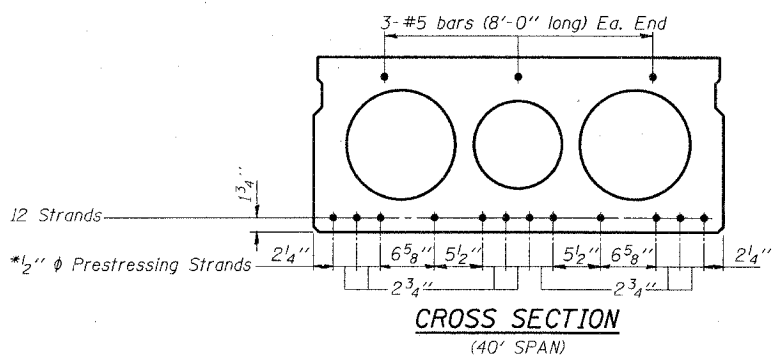
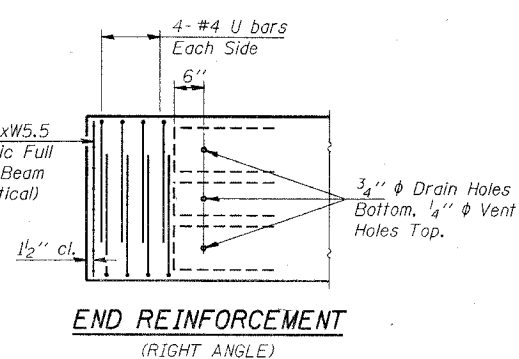
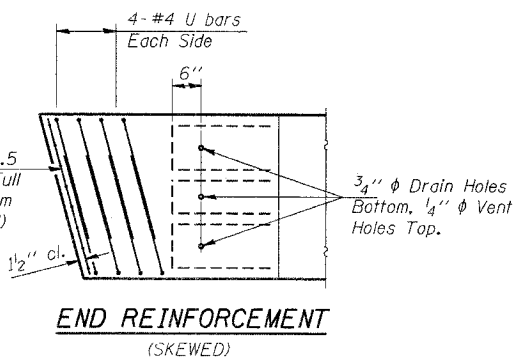

DESIGN STRESSES

- $f'_c = 5,000$ p.s.i.
- f'_{ci} (See Required Release Strength Table)
- $f'_s = 270,000$ p.s.i. (1/2" ϕ Strand)
- $f_{si} = 189,000$ p.s.i. (1/2" ϕ Strand)
- $f_y = 60,000$ p.s.i.

REQUIRED RELEASE STRENGTH

Span	f'_{ci} (psi)
30'	4,000
35'	4,000
40'	4,000
50'	4,000

NOTES

- Prestressing steel shall be uncoated high strength, stress relieved 7-wire strand, Grade 270.
- The nominal diameter shall be 1/2" and the nominal cross-sectional area shall be 0.153 square inches.
- Reinforcement bars shall conform to AASHTO M-31, M-42 or M-53, Grade 60.
- On 0°, 5° and 10° skews, alternate approved transverse tie rods of increased segmental length are acceptable.
- Rail Post anchor devices shall be cast into outside beam as elsewhere specified.
- When Waterproofing Membrane System is specified, the top surface of the beams shall be finished in accordance with Article 504.06 of the Standard Specifications except that the surface shall not be roughened by brooming. The finished surface shall be free of depressions or high spots with sharp corners, and the top edge of keys shall be rounded or chamfered a minimum of 1/4".
- Low-relaxation strands may be substituted for the stress relieved strands. The initial prestressing force applied to each strand shall be the same as for the stress relieved strands (28,900 lbs.).
- Keyway surfaces shall be cleaned to remove form oil or other bond breaking material prior to shipment of the beams. Cleaning shall be done by sandblasting the keyway areas between the top of the beam and the bottom edge of the key.

Illinois Department of Transportation

PASSED NOVEMBER 1, 1995

Greg J. Kasper
Engineer of Bridge Design

APPROVED NOVEMBER 1, 1995

Walter E. Anderson
Engineer of Bridges and Structures

NOTE: The std. reinf. shown on the 30' span cross section is typical for all spans, except as shown.

P.P.C. DECK BEAM DETAILS

28' ROADWAY 21" x 48" BEAMS

STANDARD CB-2821-48